

National Grid UK Electricity Transmission plc



Uncontrolled when printed

Safety Rules and Guidance (Fourth Edition)

Copyright National Grid plc 2013©, all rights reserved. No part of this publication may be reproduced, stored in a retrieval system, or transmitted in any form or by any means electronic, mechanical, photocopying, recording or otherwise, without the written permission of National Grid obtained from the issuing location.

The contents of National Grid documents are based on the needs of National Grid and the conditions under which it operates. It shall not therefore be assumed that the contents stated therein necessarily meet the particular circumstances and requirements of other organisations. The principles set out in this document are for information only and therefore National Grid is not liable to any third party for any loss or damage resulting from reliance on the contents. It is the responsibility of such external organisations to check that the document is the latest version and is appropriate for their purposes.

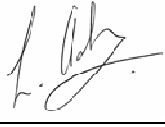
DOCUMENT HISTORY

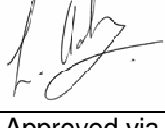
Issue	Date	Summary of Changes / Reason	Author(s)	Approved By (Title)
2	28/12/07	Re-write of Guidance Document to line up with Third Edition Safety Rules Ex Network Services Procedure WE1000 embedded into guidance	Safety Rules Review Working Group	MDE Manager, Les Adams 
3	27/03/09	Re-issue of Guidance Document as part of annual review. Minor text changes and Key Changes as identified below,. Modified or inserted text identified by yellow highlighting. Safety Bulletin SB 171 embedded into guidance.	Safety Rules Assurance Team	MDE Manager, Les Adams 
4	04/04/11	Annual review; document amended as detailed below and minor text changes as highlighted in yellow.	NSI Review Group	MDE Manager, Les Adams 
5	02/04/12	Annual review; document amended as detailed below and minor text changes as highlighted in yellow.	NSI Review Group	MDE Manager, Les Adams 
6	01/10/13	5 Year Review. Renamed as "Safety Rules and Guidance" Fourth Edition which now incorporates and replaces Safety Rules Issue 3.02 and Safety Rules Guidance Issue 5.	Safety Rules Review Group	Approved via SEDDs Mike Dean (ETAM) Clare Naunton (SSR)

KEY CHANGES

Section	Amendments
<p>Definition D25d</p> <p>Definition D25e</p>	<p>Words “Authorised Person” replaced by “Competent Person” as Authorised Person is not a pre-requisite for authorisation</p> <p>Word “Person” replaced by “individual” as Person is not a pre-requisite for authorisation.</p>
<p>R 3.1 and R 3.1 Guidance</p>	<p>Words “, excluding operational and safety switching,” deleted from rule and “Operational and Safety switching is controlled by appropriately authorised Personnel and the application of NSI 1, NSI 2, and therefore does not require prior assessment by a Senior Authorised Person” removed from Guidance</p>
<p>R 3.1 Guidance, R 4.1 Guidance, R 5.1 Guidance</p>	<p>Guidance added for when contractor’s RAMS adequately cover Safety from the System.</p>
<p>R 3.2c Guidance and R 3.2d Guidance</p>	<p>Sentence moved from paragraph d to paragraph c and wording changed to reflect actual process.</p>
<p>R 3.2d Guidance</p>	<p>Removal of words” (unless the work requires the removal of Primary Earth(s) under a Sanction for Work) “</p>
<p>R 3.2 Guidance</p>	<p>Words and picture included for working on Earth Switch associated with Point of Isolation to incorporate SB306.</p>
<p>R 3.4 Guidance</p>	<p>Addition of the requirement for a Key Safe Key holding ROMP items in suspension to be issued to the Competent Person and addition of requirement for completed Status of Transfer Forms to be retained. Removal of requirement to put a key safe key in Operational Key Cabinet.</p>
<p>R 3.6 Guidance</p>	<p>Addition of the word “portable” to indicate that personal supervision of SAP is not necessary for fixed drain earths outside the work area.</p>
<p>R 4.3c Rule and Guidance and R 4.3b Guidance</p>	<p>“Oral Instruction” removed and requirements for RAMS included</p>
<p>R 4.4a Guidance and R 4.4b Guidance</p>	<p>Paragraphs swapped around to correct order.</p>
<p>R 7.1 Guidance and P 6.2 Guidance</p>	<p>Words added to incorporate words from SB311 for multiple working parties.</p>
<p>P 4 Guidance</p>	<p>Guidance incorporated to allow earthing of high level busbars when low level busbars prevent access, G3 Procedure no. 13 incorporated.</p>
<p>P 4.1m Guidance</p>	<p>Paragraphs added giving detail of when issuing a safety document using 2 SAPs.</p>
<p>P 6.1 Guidance</p>	<p>Wording amended to reflect that the Working Party Register may be embedded in the MDE RAMS.</p>
<p>P 8.1 Guidance</p>	<p>Sentence added to clarify the requirement for Working Party members to sign off Working Party Register when Safety Document is surrendered.</p>

P 9.1c Guidance	Addition of Switch Disconnectors as items that cannot be returned back as a Point of Isolation.
P 13.3 Guidance	The words “at the point of work” removed as this may not be possible if a Competent Person is holding multiple Safety Documents and providing local supervision.
P 14 Guidance	Detail added to clarify management of Drain Earthing for Multiple Safety Documents

Contents Page

Introduction	1
Specific Interpretations	2
Statement of Policy, Philosophy and Principles	3
National Grid Electricity Transmission Safety Rules and Guidance (Fourth Edition)	
Definitions	5
General Provisions	9
G1 General Safety	9
G2 Safety Rules, Instructions and Procedures	9
G3 Special Instructions	10
G4 Objections on Safety Grounds	10
The Eight Basic Safety Rules	11
R1 Application of the Rules	11
R2 Approach to Exposed High Voltage Conductors and Insulators	12
R3 Safety Precautions for Work on or Near to High Voltage Equipment	16
R4 Safety Precautions for Work on or Near to Low Voltage Equipment	24
R5 Safety Precautions for Work on or Near to Mechanical Equipment	27
R6 Operation of Equipment	29
R7 Demarcation of Work Areas	29
R8 Identification of Equipment	30
Safety Document Procedures	32
P1 General	32
P2 Application	32
P3 Safety Precautions	33
P4 Preparation of Safety Documents	35
P5 Issue of Safety Documents	40
P6 Receipt of Safety Documents	42
P7 Additional Work Subsequent to Issue of a Safety Document	43
P8 Transfer of Safety Documents	44
P9 Clearance of Safety Documents	45
P10 Cancellation of Safety Documents	47
P11 Return to Operational Service	48
P12 Categories of Authorisation	49
P13 Safe Custody of Safety Documents and Associated Items	49
P14 Multiple Safety Documents	50
Form of Documents	52
Guidance Notes for Documents	71

Introduction

The **Company** Safety Rules are provided to ensure that work can be undertaken safely on or near to items of **Equipment** that form part of the **System**.

The Safety Rules are mandatory. It is the duty of every person who may be concerned with work on or near to the **System** to make themselves thoroughly familiar with the detail of the relevant Safety Rules and appropriate supporting documents. In addition all persons have a general duty to be conversant with and to observe statutory requirements relating to any activity with which they have an involvement.

It is the responsibility, under the Health and Safety at Work etc. Act 1974, and Regulations made under it, that all persons employed will take reasonable care for the health and safety of themselves and other persons who may be affected by their acts or omissions.

The Eight Basic Safety Rules are based on a hierarchy of controls and as such must be read in sequence to ensure that the safest level of control is always used. To ensure that the ethos of the rule is applied in full all paragraphs need to be read in context.

The statement of Policy, Philosophy and Principles do not form part of the Safety Rules. It is included for general information.

Specific Interpretations do not form part of the Safety Rules but are terms used within the rules to reflect Health and Safety legislation.

Work - When used in these Rules the term 'work' includes testing and operational and safety switching.

Gender - All references in these Rules to the masculine gender shall include the feminine.

These 'Guidance Notes' which supplement the Fourth Edition National Grid Safety Rules, have been written to clarify the application of the Safety Rules across the wide range of work carried out on both substation and overhead line operational sites.

It has been formulated from previous documents on guidance and also from experience across the population of **Senior Authorised Persons** within the organisation. Although not exhaustive, this handbook reflects current thinking and standards within the organisation and drives a consistent approach to the application of the rules across National Grid.

The layout of this handbook reflects legislative codes of practice, whereby the rule (or mandatory obligation) is identified by a green panel on the left-hand side. The guidance follows after the rule and is identified by a blue panel.

Within National Grid the guidance handbook holds the equivalent standing as an Approved code of Practice (ACOP) in law. If not followed, you will be required to demonstrate that your safe system of work is of an equal or higher standard.

Terms printed in bold type are as defined in the National Grid UK Electricity Transmission plc Safety Rules Fourth Edition.

Specific Interpretations

1 **Shall**

When 'shall' is used in these Rules with no qualification, this indicates a mandatory requirement. No discretion is permitted and no judgement can be made.

2 **Shall, where practicable**

When 'shall, where practicable' is used to qualify a requirement, a slightly less strict standard is imposed. It means that where it is possible to achieve, in the light of current knowledge and invention, then the requirement shall be met. To avoid the requirement on the grounds of difficulty, inconvenience or cost is not allowed.

3 **Shall, where reasonably practicable**

When 'shall, where reasonably practicable' is used to qualify a requirement, then a judgement shall be made as to what is reasonable. This shall take into account an assessment of the magnitude of the risk on the one hand and the cost, time and trouble, and effort necessary for averting the risk on the other hand.

Statement of Policy, Philosophy and Principles

1 Policy

- 1.1 The **Company** “Safety and Well-being Policy” outlines our vision and commitment to health and safety. This Policy takes account of a wide-range of health and safety legislation under which the businesses within National Grid operate primarily the Health and Safety at Work Act 1974. It also takes account of standards and best practice introduced by such businesses to improve safety behaviours.
- 1.2 The “Safety and Well-being Policy” makes specific reference to maintaining high standards of safety performance. There is a requirement to meet, and where appropriate, exceed the requirements of health and safety legislation, policies, and other commitments to which National Grid subscribe. These Rules have been formulated taking into account principally the Electricity at Work Regulations 1989 and the Management of Health and Safety at Work Regulations 1999.
- 1.3 The **Company** recognises and accepts its statutory and moral responsibilities for ensuring our assets are designed, constructed, operated and maintained to standards that promote good safety performance through the life of the asset and when decommissioned.
- 1.4 Protecting the safety, health and welfare of National Grid employees and others who work for National Grid is of prime importance. It is National Grid’s responsibility to conduct operations in ways that are most protective of public safety.
- 1.5 The successful execution of the Policy relies on all employees complying with safety requirements relevant to their responsibilities.

2 Philosophy

- 2.1 The Company’s electrical and mechanical items of **Equipment** are interconnected to form electromechanical systems. These systems contain inherent dangers but are designed so that when operated normally they are safe.
- 2.2 When work is to be carried out on, or near to, these systems, Rules need to be specified to achieve safety from the inherent dangers.
- 2.3 These Safety Rules are based on a philosophy that persons will be protected from the inherent dangers. This is achieved by making them “safe from the **System**”.
- 2.4 The inherent dangers are those arising from a **System**. The Rules define procedures and responsibilities for achieving safety of persons from the inherent dangers. They may be summarised as follows:
 - a) Making available the **Equipment** concerned for the work.
 - b) Establishing safe conditions for work. This can be achieved by either limiting the scope of the work, or isolation from a **System**. Specialised procedures will be applied when the work has to be done on **Equipment** which remains energised.
 - c) Authorising the commencement of work.
 - d) Receiving the authority to commence work, executing the work, supervising safety during the work and clearing the authority when the work is terminated.
 - e) Cancelling the authority on termination of the work.
 - f) Restoring the system to normal.

- 2.5 Further dangers are those arising from the environment in which persons undertake work. The way in which these dangers are managed shall be specified in Management Procedures.
- 2.6 The Rules will be supported by National Safety Instructions and Guidance Notes.

3 Principles

- 3.1 To fulfil the requirements of the Philosophy, the following principles have been adopted in formulating the Rules.
- a) The Rules are only concerned with achieving safety for persons.
 - b) When work is to be carried out on **Equipment** the primary means of achieving safety is by **Isolation**. Where practicable the **Isolating Devices** shall be **Locked**. In the case of **High Voltage Equipment**, this shall be followed by earthing. Where reasonably practicable the **Earthing Devices** shall be **Locked**. In the case of mechanical **Equipment** this shall be followed by draining venting and purging as appropriate.
 - c) **Approved** specialised procedures shall be required for work where **Isolation** is not reasonably practicable, or where normal **Isolation** procedures cannot be applied.
 - d) Persons shall be formally appointed to carry out defined duties.
 - e) Application shall ensure that safety is maintained across all internal and external control boundaries and interfaces.
 - f) The achievement of **Safety from the System** will involve one or more of the following functions; Control, Making Safe/Restoration of **Equipment**, and Work. These three functions cover different responsibilities which are treated separately in the Rules. The Rules do not preclude one person from performing all three functions.

Definitions

D1	Approved	Sanctioned for use by the Head of UK Safety and Maintenance Delivery Electricity Manager.
D2	Card Safe	A lockable device for the secure retention of Safety Document(s) and the associated Key Safe Key(s).
D3	Caution Notice	A notice conveying a warning against interference which shall be attached at all Points of Isolation .
D4	Charged	At a voltage when Isolated from the System by induction or a retained charge due to capacitive effects
D5	Circuit Identification	Colours or symbols used to identify overhead line circuits and other Equipment .
D6	Company, The	National Grid UK Electricity Transmission plc.
D7	Consent	Confirmation by the Control Person (Safety) , before the issue of a Safety Document , that safety precautions have been carried out on the correct Equipment and that procedures have been put in place to maintain these until the Safety Document is cancelled.
D8	Danger	A risk to health, or bodily injury.
D9	Dead	Not electrically Live or Charged .
D10	Earthed	Connected to earth by means of an Earthing Device .
D11	Earthing Device	A means of providing a connection between an electrical conductor and earth, being one of the following:- a Primary Earth A type registered fixed or portable Earthing Device applied to an electrical conductor to protect against inadvertent energisation. b Drain Earth A type registered fixed or portable Earthing Device applied to electrical Equipment for the purpose of protection against Charged Equipment and management of circulating currents.
D12	Earthing Schedule	A schedule indicating the Drain Earth requirements for each stage of work.
D13	Equipment	Electrical and mechanical operational assets to which the Safety Rules apply.
D14	General Safety	The provision and maintenance of safe access to and from the place of work, a safe place of work, a safe working environment, safe systems of work and the correct use of personal protective equipment.
D15	High Voltage (HV)	A Voltage exceeding 1000 volts.
D16	Isolated	Disconnected from associated Equipment by the operation of an Isolating Device to the isolating position or by adequate physical separation which shall ensure the isolation gap cannot fail electrically.

D17	Isolating Device	A device for rendering Equipment Isolated
D18	Keys	Being one of the following:- a Control Key A key for operating the control lock of a Key Safe b Safety Key A key unique at the Location for locking an Isolation Device, Earthing Device , vent or drain device / valve. c Key Safe Key A key unique at the Location for operating a lock, other than the control lock, on a Key Safe .
D19	Key Safe	A lockable device for the secure retention of Keys links and fuses.
D20	Live	At a voltage by being connected to a source of electricity.
D21	Location	Any place at which work under the Company Safety Rules are carried out.
D22	Locked	A condition of Equipment that cannot be altered without the operation of a secure fastening device.
D23	Low Voltage (LV)	A voltage up to and including 1000 volts.
D24	Operational Service	Under operational control of a Control Person (Operation) .
D25	Personnel	Being one of the following:- a Person An individual with sufficient technical knowledge or experience to avoid Danger . b Competent Person A Person who has been appointed by an appropriate officer of the Company to carry out duties specified in writing including the receipt, transfer and clearance of Safety Documents . c Authorised Person A Person who has been appointed by an appropriate officer of the Company to carry out operational and safety switching duties as specified in writing. d Senior Authorised Person A Competent Person appointed by an appropriate officer of the Company to carry out duties specified in writing, including the preparation, issue, transfer and cancellation of specified Safety Documents .

e	Control Person(s)	Being one of the following:-
	Control Person (Operation)	An individual who has been appointed by an appropriate officer of the Company , or other Companies, to be responsible for the operational control and co-ordination of the System within and across defined boundaries. They can also transfer temporary control of a part of the HV System using a System State Certificate .
	Control Person (Safety)	An individual who has been appointed by an appropriate officer of the Company , or other Companies, to be responsible for controlling and co-ordinating safety activities necessary to achieve Safety from the System within and across defined boundaries. They can also receive temporary control of a part of the HV System using a System State Certificate .
D26	Point(s) of Isolation	The point at which Equipment has been Isolated and where practicable, or in the case of LV Equipment where reasonably practicable, the isolation point immobilised and Locked . Caution Notices shall be attached at all Points of Isolation .
D27	Purged	A condition of Equipment from which any dangerous contents have been removed.
D28	Safety Distance	The distance from the nearest High Voltage exposed conductor, or from an insulator supporting a High Voltage conductor, which shall be maintained to avoid Danger .
D29	Safety Documents	Being one of the following:-
	a Permit for Work	A Safety Document of a design shown in these Rules specifying the Equipment , the work to be carried out and the actions taken to achieve Safety from the System
	b Limited Access Certificate	A Safety Document of a design shown in these Rules specifying the Equipment , the work to be carried out and the limits of the work and/or work area necessary to achieve Safety from the System
	c Sanction for Work	A Safety Document of a design shown in these Rules specifying the HV Equipment , the work to be carried out which requires the removal of Primary Earths and the actions taken to achieve Safety from the System .

-
- d **Certificate for Live LV Work** A **Safety Document** of a design shown in these Rules specifying the **LV Equipment**, the work which is to be carried out **Live** and the precautions to be taken to achieve a safe system of work.
- D30 Safety from the System** That condition which safeguards persons working on or near to **Equipment** from the **Dangers** which are inherent in a **System**.
- D31 Supervision** Being one of the following:-
- a **Local Supervision -** A level of supervision whereby the nominated **Personnel** is available at the **Location** where the work is being carried out and able to attend the point of work as necessary.
- b **Personal Supervision -** A level of supervision whereby the nominated **Personnel** is continuously observing and in the presence of the individual(s) with the ability to directly intervene.
- When individual(s) are working at height supervision can be given at ground level providing verbal and visual communication is maintained at all times.
- This level of supervision shall ensure individual(s) are not exposed to **Danger**.
- D32 System** Items of **Equipment** which are used separately or in combination for the generation, transmission or distribution of electricity.
- D33 System State Certificate** A certificate which defines the boundaries of that part of a **System** for which the control is to be transferred between a **Control Person (Operation)**¹ and a **Control Person (Safety)**¹.
- D34 Vented** Having an outlet to the atmosphere so that pressure is equalised to atmospheric pressure.
- D35 Working Party** Individuals working under the **Personal Supervision** of a **Competent Person** or **Persons** working under the **Local Supervision** of a **Competent Person**, including a **Competent Person** or **Person** working alone.

General Provisions

Safety Rule General provisions G1

G1 General Safety

- G1.1 In addition to the requirements for establishing **Safety from the System** specified in these Safety Rules, **General Safety** shall be established and maintained at all times.
- G1.2 **General Safety** shall be established before work starts. The roles and responsibilities for establishing **General Safety** shall be specified in a Management Procedure.
- G1.3 During the course of the work **Personnel** in charge of the **Working Party** shall ensure that all members of the **Working Party** maintain **General Safety**. In addition he shall ensure that other work areas are not adversely affected by their activities.

Guidance General provisions G1

G1 General Safety

- G1.2 The Safety Rules do not identify the roles and responsibilities for establishing and maintaining **General Safety**. These are identified within the Management Procedure AMBP 310 'Work and Work Execution' and "CDM Management Procedures", TP137 or AMBP 051
- G1.3 Management Procedure AMBP 310 "Work and Work Execution" identifies the roles and responsibilities.

Safety Rule General provisions G2

G2 Safety Rules, Instructions and Procedures

- G2.1 The Safety Rules and the requirements of supporting documents are mandatory. In addition relevant Rules issued by other relevant authorities are similarly mandatory.

Guidance General provisions G2

G2 Safety Rules, Instructions and Procedures

- G2.1 The Safety Rules are supported by National Safety Instructions (NSI's). These are mandatory and shall be applied at all National Grid **Locations**. The principles contained in them shall be adhered to at all times.

When National Grid staff work in areas where Distribution Network Operators, Generating Companies, or other Companies Safety Rules apply, these are also mandatory.

Interface arrangements for managing site specific issues are laid down in the Site Responsibility Schedules.

Safety Rule

General provisions
G3

G3 Special Instructions

G3.1 If for a special reason the Safety Rules cannot or should not be applied, the work shall be carried out in accordance with an **Approved** G3 procedure.

Guidance

General provisions
G3

G3 Special Instructions

G3.1 Where it is impossible to apply the Safety Rules or there are strong commercial or technical reasons for not applying the Rules, **Safety from the System** can be achieved by carefully planned, risk assessed alternative methods. When there are strong commercial or technical reasons legal advice shall be sought. Instructions shall be specified in an **Approved** written G3 Procedure.

An example of where the Safety Rules cannot be applied is where the normal procedures for the clearance of a **Safety Document** cannot be completed due to the absence of the recipient, loss of **Safety Keys**, or any associated items issued with the **Safety Document** e.g. flags and wristlets.

A register of **Approved** G3 Procedures shall be maintained and available in Management Procedure NSI 32 – “Register of Approved Procedures”.

The addition/removal of G3 Procedures shall be carried out in accordance with the requirements of Management Procedure NSI 31 – “Approval of Procedures for National Grid Safety Rules”.

Safety Rule

General provisions
G4

G4 Objections on Safety Grounds

G4.1 Anyone who has objections on safety grounds in the application of the Safety Rules shall explain their reasons to the person giving the instructions. These objections shall be dealt with in accordance with an **Approved** G4 Procedure.

Guidance

General provisions
G4

G4 Objections on Safety Grounds

G4.1 Personnel working under the Safety Rules shall be aware of this procedure as part of their initial authorisation.

The **Approved** G4 Procedure shall be maintained and available in Management Procedure NSI 32 – “Register of Approved Procedures”.

The Eight Basic Safety Rules

Safety Rule

The Eight Basic
Safety Rules
R1

R1 Application of the Rules

- R1.1 The Safety Rules shall be applied when working on or near to items of **Equipment** which are part of a **System**.
- R1.2 **Equipment** shall be added to and removed from a **System** only in accordance with a Management Procedure. This procedure will determine when these Safety Rules shall apply or cease to apply to that **Equipment**.

Guidance

The Eight Basic
Safety Rules
R1

R1 Application of the Rules

- R1.1 Mechanical and electrical equipment to which the Safety Rules do not apply may also have inherent dangers. Legislation requires that safe systems of work shall be established and maintained. Management Procedure “Work and Work Execution” provides information about Category 3 work and provides examples of what equipment may be designated as being outside the **System**.

Fire protection systems associated with the Transmission system shall be considered part of the **System**, and therefore identified as **Equipment**, for the purposes of establishing **Safety from the System**.

- R1.2 Management Procedure NSI 33 – “The Addition/Removal of Equipment to/from the System”, lays down the requirements to be followed when adding **Equipment** to or removing **Equipment** from the **System**.

Sometimes temporary connections are made to measure distances e.g. down leads, etc. If these connections are made to any **Equipment** forming part of the **System**, then they become part of the **System** (this does not apply to test connections to discrete test equipment). Under such circumstances the temporary connections and any **Equipment** they are connected to, are an addition to the **System** and are subject to the requirements of Management Procedure NSI 33 – “The Addition/Removal of Equipment to/from the System”.

Temporary removal of disconnected **Equipment** to workshops or similar work areas may be considered as removal from the **System** for the period of the work. In these circumstances the formal requirements of the Safety Rules do not apply. However, it is still necessary to ensure that safe systems of work are established and maintained including protecting against hazards, such as stored energy or toxic residues.

If any conductors or equipment are connected to any **Equipment** forming part of the National Grid **System**, then it becomes part of that **System**. However, Management Procedure - “Work and Work Execution” clarifies items of equipment designated as being outside the **System**.

Safety Rule

The Eight Basic
Safety Rules
R2.1 to R2.3

R2 Approach to Exposed High Voltage Conductors and Insulators

R2.1 Individuals shall not allow any part of their body or objects to approach within the specified **Safety Distance(s)**, detailed in R2.4, to exposed **HV** conductors. The only exception is:-

- **Live** line working carried out on **HV Equipment** in accordance with an **Approved** procedure
- Application of Safety Rule R2.2 or R2.3

R2.2 When **Point(s) of Isolation** have been established, exposed conductors could still be **Charged at High Voltage**. The only objects permitted to approach within the specified **Safety Distance(s)**, within the zone established by **Point(s) of Isolation**, in this condition, shall be type registered:-

- Voltage measuring devices
- **Earthing Device(s)** and their associated application devices

R2.3 a) When **Point(s) of Isolation** have been established and **Danger** has been excluded by the application of **Earthing Device(s)**, within the zone established by **Point(s) of Isolation**, encroachment within the specified **Safety Distance(s)**, is permitted under an appropriate **Safety Document**.

b) Encroachment within the specified **Safety Distance** is permitted without the issue of a **Safety Document** only under the following circumstances:-

- i) When **Point(s) of Isolation** have been established for **Equipment** in interlocked cages, where it is not reasonably practicable to maintain **Safety Distance**, within the zone establish by **Point(s) of Isolation**, individuals may encroach no closer than 1 metre from the exposed **High Voltage** conductors for the application or removal of type registered devices specified in R2.2 above.
- ii) When **Point(s) of Isolation** have been established in indoor hall type 132 kV substations, where it is not reasonably practicable to maintain **Safety Distance**, within the zone establish by **Point(s) of Isolation**, individuals may encroach within the specified **Safety Distance** for the application or removal of type registered devices, specified in R2.2 above, to the busbar side of busbar isolators and bus coupler / bus section isolators, providing the **High Voltage** conductor to be approached is **Earthed** via a fully rated **Earthing Device**.

Guidance

The Eight Basic
Safety Rules
R2.1 to R2.3

R2 Approach to Exposed High Voltage Conductors and Insulators

R2.1 It is important to note that this is an approach Rule to exposed **High Voltage** conductors and insulators. **Live** work is only permissible following formal Risk Assessments, establishment of safe systems of work, and special **Approved Live** line working procedures must be followed.

R2.2 For information clarifying roles, responsibilities and appropriate authorisations for the application and removal for **Earthing Devices** reference should be made to Management Procedure NSI 2 – “Earthing High Voltage Equipment”.

Type Registered List TRL 2.2 part 4 – “Substation Portable Earthing Equipment” and TRL 2.2 part 5 – “OHL Portable Earthing Equipment” identifies the Earthing Devices and their associated application devices that are available for use.

R2.3a For **Point(s) of Isolation** using Centre Rotating Isolators, **Safety Distance** shall be maintained from the exposed **Live** conductors. Although the centre section is in a **Charged** condition, the **Safety Distance** applied from the **Live** exposed conductors, ensures **Danger** is excluded from the **Charged** conductor.

Management Procedure NSI 4 - “Work on or Near High Voltage Overhead Lines” details procedures required for the management of circulating currents.

R2.3bi For **Equipment** in interlocked cages, it is not always reasonably practicable to maintain **Safety Distance** during the application / removal of portable **Earthing Devices** / voltage measuring devices due to its inherent design.

Due to the inherent safe guards associated with interlocked cages and the low levels of induced voltages present, approach to exposed conductors no closer than a distance of 1 metre is allowed for the application / removal of portable **Earthing Devices** / voltage measuring devices.

The distance of 1 metre (including all associated arcing horns, stress shields, etc) must be maintained at all times during the application / removal of portable **Earthing Device** / voltage measuring devices.

For the application of portable **Earthing Devices** the **Senior Authorised Person** must carry out a written risk assessment as detailed in Management Procedure NSI 2 - “Earthing High Voltage Equipment”.

Guidance

The Eight Basic
 Safety Rules
 R2.3 Cont.

R2.3bii Where it is not reasonably practicable to maintain **Safety Distance**, individuals may approach within the specified **Safety Distance** when applying **Earthing Devices** to the busbar side of busbar isolators and bus coupler isolators.

Calculations have proved that the induced voltage has been reduced to a negligible level by the application of a solidly connected fixed **Earthing Device**. The **Senior Authorised Person** shall ensure that no **Personnel** make bodily contact with exposed **HV** Conductors during the application or removal of any portable **Earthing Devices**.

For information on the application and removal for **Earthing Devices** reference should be made to Management Procedure NSI 2 – “Earthing High Voltage Equipment”.

If all of the above processes cannot be achieved, application and removal of portable **Primary Earths** shall be completed under an **Approved G3 Procedure**. For the application of portable **Earthing Devices** the **Senior Authorised Person** must carry out a written risk assessment as detailed in Management Procedure NSI 2 - “Earthing High Voltage Equipment”.

Safety Rule

The Eight Basic
 Safety Rules
 R2.4

R2.4 **Safety Distances**

Rated System Voltage	Safety Distance
kV	Metres
Up to 33	0.8
66	1.0
132	1.4
275	2.4
400	3.1

A distance of 300mm shall also be maintained from that part of the insulators supporting exposed unearthed **High Voltage** conductors which are outside the appropriate **Safety Distance** (see diagram).

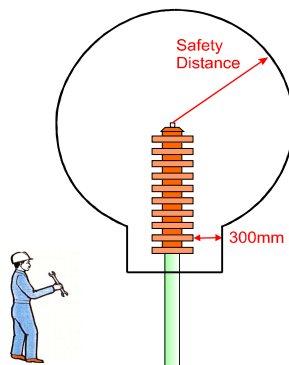

Guidance

The Eight Basic
Safety Rules
R2.4

R2.4 The **Safety Distances** specified are the minimum distances in air to be maintained between exposed **High Voltage** conductors or supporting insulators and a person's body. This will also include any machinery, hand held tools, vehicles, long objects etc. being utilised by the person.

Safety Distance, shall be maintained from all parts of the **Equipment**. This must include any parts that may protrude or extend to a lower level, e.g. stress shields, arcing horns, corona rings, current transformer housing etc. that are connected to the exposed **HV** conductor.

When work is to be carried out near to the **Safety Distance**, the **Senior Authorised Person** shall ensure that scaled drawings and other means of checking dimensions are available at the planning stage of the work to enable distances to be measured and assessed accurately.

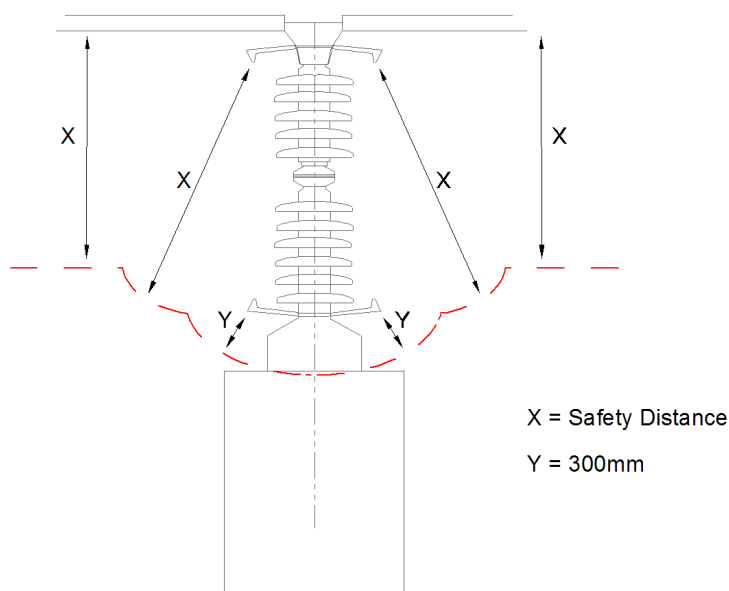

Safety Rule

The Eight Basic
Safety Rules
R3.1 to R3.2

R3 Safety Precautions for Work on or Near to High Voltage Equipment

R3.1 When work is to be carried out on or near to **HV Equipment**, a **Senior Authorised Person** shall assess the means of achieving **Safety from the System**. When **Safety from the System** can be achieved by limiting the work or work area, instructions clearly defining the limitations shall be given. When the **Senior Authorised Person** decides it is necessary to confirm these instructions in writing, he shall consider issuing a **Limited Access Certificate**.

R3.2 When **Safety from the System** cannot be achieved by limiting the work or work area from **HV Equipment**, the following safety precautions shall be applied:-

- a) The **HV Equipment** shall be identified by either the Planning Process or the **Senior Authorised Person**, and the **Control Person (Operation)** shall prepare, then release it from **Operational Service**.
- b) The **Control Person (Operation)** shall issue a **System State Certificate** to transfer control of the **HV Equipment** to a **Control Person (Safety)**.
- c) The **Control Person (Safety)** shall ensure that the **Equipment** is **Isolated** and that **Point(s) of Isolation** are established for the work. **HV Point(s) of Isolation** shall where practicable be **Locked**.
- d) **Primary Earth(s)** shall be applied within the zone established by the **Points of Isolation**. Where reasonably practicable the **Primary Earth(s)** shall be **Locked**.

Where a single item or unit of **HV Equipment** has been specifically designed to provide a combined **Isolation** and **Earthing** function and where it is safe to do so, **Primary Earthing** may be applied in an **Isolated** zone before **Point(s) of Isolation** have been created.

- e) The contents of the **HV Equipment** shall be adjusted to a level that avoids **Danger**. Where drain valves are used they shall where practicable be **Locked** in the appropriate position.
- f) Where **Danger** could arise from pressurisation, the **HV Equipment** shall be **Vented**. The emissions shall be dissipated so as to avoid **Danger**. Where reasonably practicable vents shall be **Locked** open.
- g) Where internal access is required, and the residue of contents could cause **Danger**, the **HV Equipment** shall be **Purged**. The emissions shall be dissipated so as to avoid **Danger**. The **Equipment** shall be restored to atmospheric pressure when purging is complete.
- h) Where **Danger** could arise from the release of stored energy, action shall be taken to contain, equalise or dissipate this energy safely.

Guidance

The Eight Basic
Safety Rules
R3.1

R3 Safety Precautions for Work on or Near to High Voltage Equipment

R3.1 When a contractor's risk assessment adequately covers **Safety from the System** aspects, there is no need for the **Senior Authorised Person** to record a separate **Safety from the System** risk assessment. In this case, the SAP may annotate the contractor's RAMS "This documented safe system of work when implemented is sufficient to achieve **Safety from the System** from National Grid's electricity transmission system".

When **Safety from the System** is achieved by limiting the work or work area there shall be no foreseeable risk of infringement of **Safety Distance**.

When the **Senior Authorised Person** decides it is necessary to confirm these instructions in writing, he shall, record the assessment and controls to be applied in AMBP 311 RAMS. Where the RAMS controls all **Safety from the System** hazards there is no requirement to issue a **Limited Access Certificate**.

Where contractors are carrying out work near to **Equipment** and the means of achieving **Safety from the System** is by limiting the work or work area, a **Senior Authorised Person** shall confirm these instructions in writing by the issue of a **Limited Access Certificate**. The only exception to this requirement is where the identified work, and / or work area as detailed and controlled in the risk assessment and method statements are limiting in their own right, thus ensuring there is no risk from the **System**. An example of this would be risk assessment and method statement detailing the painting of a blockhouse door from ground level.

Senior Authorised Person(s) carrying out the risk assessment under Rule R3.1 must take into account not only the proximity of the **HV Equipment** but also the tools and equipment to be used, the competence of the workers and the actual work being carried out.

An example of a high risk activity could be erection of a scaffold structure. Clearly this involves moving objects, i.e. scaffold poles, thus loss of control is a foreseeable risk and this must be taken into account in the risk assessment.

Where risk of infringement of **Safety Distance** is assessed to be unacceptably high, then a circuit outage should be requested formally through the planning process.

Should an outage request be refused on grounds of cost and / or **System** security the work need not necessarily be cancelled.

The Electricity at Work Regulations allows work to continue providing it can be justified in all circumstances that:

- It is unreasonable to make the **Equipment Dead**, i.e. due to cost and / or **System** security
- It is reasonable to be at work on or near to the **Equipment** while it remains **Live** and
- Suitable precautions, including the provision of suitable protective equipment, are taken to prevent injury

The work could therefore proceed providing the risk of infringement of **Safety Distance** is adequately controlled utilising appropriate risk reduction methods. In these circumstances all risk assessments must be recorded.

Guidance

The Eight Basic
Safety Rules
R3.2

R3.2 b) Control of parts of the **HV System** can be transferred from the **Control Person (Operation)** to a **Control Person (Safety)**. The **System State Certificate** is used to transfer control between the Electricity National Control Centre (ENCC) and the Network Operations Centre (NOC), to enable the safety control function to be managed. For further guidance refer to Management Procedure - "Managing Safety Interfaces".

Gas Insulated Switchgear three position switches combine the functionality of a disconnecter and an earth switch within a device having a single set of moving contacts which have a common electrical supply. In order to operate this equipment as designed the disconnecter can be opened and selected to earth position by the **Control Person (Operation)** via telecommand prior to the issue of the **System State Certificate (SSC)**. The **Control Person (Operation)** will ensure that an **Isolated Zone** has been established prior to selecting the device to Earth position.

c) Where the integrity of a **Point of Isolation** is dependent on the presence of SF6 gas at the designed density this should be monitored throughout the work. The **Control Person (Safety)** will identify the appropriate Gas Zone. The **Control Person (Operation)** or NOC Response will be responsible for monitoring the Gas Zone and instigating appropriate actions if an alarm occurs during the work. **Where reasonably practicable, IGDD gas alarms shall be checked & confirmed prior to the Authorised Person reporting back the operations carried out to the Control Person (Safety).**

Where safety control boundaries occur between the NOC and other users of the **System** or between the NOC and substation sites, a Record of Inter System Safety Precautions (RISSP) will be issued. This could be between two **HV System(s)** or **HV and LV System**. As detailed in the Management Procedure - "UKBP SE 301 Managing Safety Interfaces".

d) **Primary Earth(s)** shall where reasonably practicable be applied between the **Point(s) of Isolation** and the point of work. Management Procedure NSI 2, – "Earthing High Voltage Equipment", deals with the situations where it is not reasonably practicable for earths to be applied between the point of work and the **Point(s) of Isolation**.

Primary Earth(s) shall, where reasonably practicable, be positioned outside the demarcated work area. If not reasonably practicable then a safe system of work shall be established to ensure that the integrity of the **Primary Earth(s)** are not affected by the work.

There is no requirement to lock portable **Primary Earths**. To distinguish portable **Primary Earths** from **Drain Earths** the application of a sign shall be applied, which states "No Unauthorised Interference". When a Sanction for Work is issued, this is classed as authorised interference.

Where items of GIS **HV Equipment** are able to provide a combined **Isolation & Earthing** function contained within an integral unit as a type registered device which provides this function, it is permissible to select the device to the **Primary Earth** position inside an **Isolated** zone before **Points of Isolation** have been created.

Guidance

The Eight Basic
Safety Rules
R3.2 Cont.

Where the device is required as a **Primary Earth**, the **Control Person (Safety)** shall check for an isolated zone before giving a **HV** safety switching instruction to select the device to the **Primary Earthing** position. This instruction shall also include an instruction to provide **Points of Isolation** such that the **Primary Earth** shall reside within a zone of **Isolation** bounded by **Points of Isolation** as soon as is practicable.

Where a control boundary exists, the **Control Person (Safety)** shall obtain the agreement of all **Users** as defined in the Grid Code before issuing a **HV** safety switching instruction

- e) Work may be carried out without the **Equipment** being completely emptied of its contents if **Safety from the System** can be achieved by adjusting the level of the contents. An example is to partially drain oil from the main tank of a transformer to gain access to the top of the transformer windings.
- g) If any residue could create **Danger**, this shall be dealt with by the safety precautions specified. Toxic or other hazards, which arise from the work activity, should be dealt with by the arrangements for ensuring **General Safety**.
- h) An example of where stored energy has to be dealt with is the venting of compressed gases from **Equipment** that has been **Isolated** but cannot be **Vented**. Other examples are valve springs, circuit breaker mechanism springs / hydraulic systems and **Charged** capacitors.

Working on Safety Precautions

Some types of **Equipment** are mounted on the same structures; e.g. earthing device and isolator / disconnectors.

Isolator / disconnector as a **Point of Isolation**, work required on **Earthing Device**:-

- No work can be undertaken on the **Earthing device** when the disconnector has been identified as a **Point of Isolation** if the integrity of the **Point of Isolation** can be compromised.
- The **Senior Authorised Person** shall ensure the following:

The work shall not affect the integrity of the Safety Precaution. How this is achieved must be clearly identified in a safe system of work.

Controls are in place to ensure **Safety from the System** is maintained from adjacent **Live HV** conductors and insulators and identified in **RAMS**.

Guidance
 The Eight Basic
 Safety Rules
 R3.2 Cont.

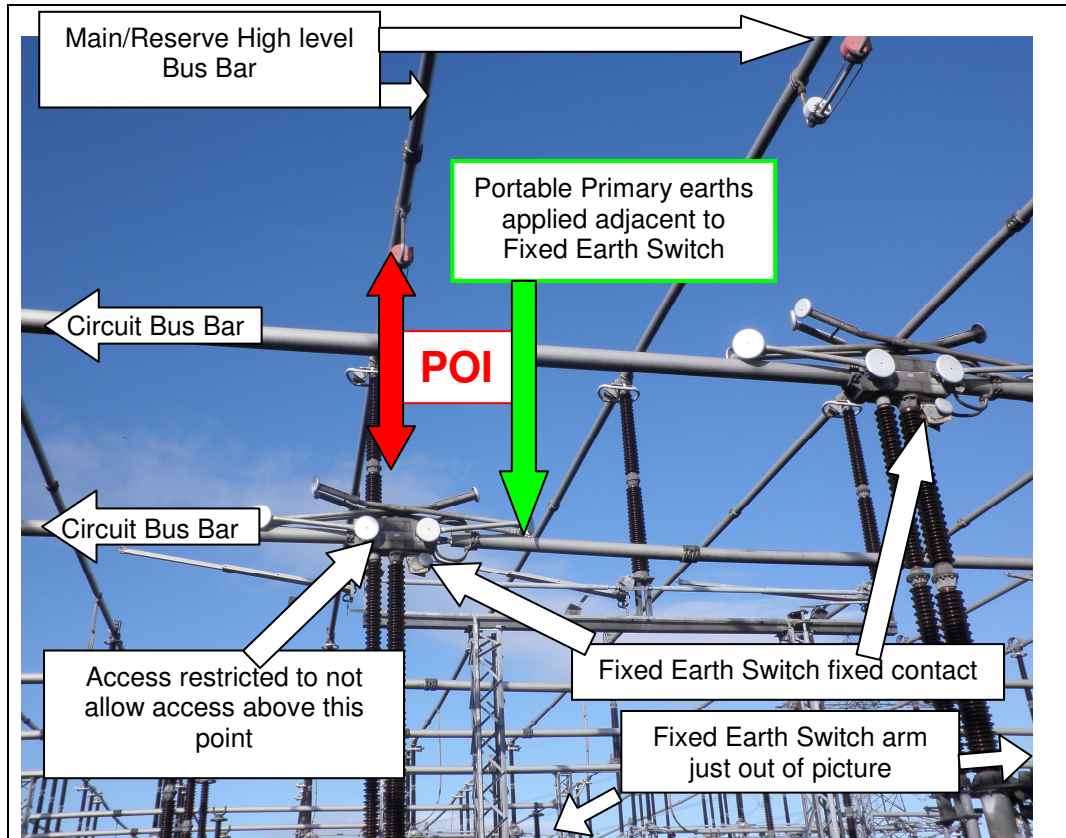

Figure 3.2a – Example of scenario where the work may proceed on Earth Switch associated with Point of Isolation.

Earthing Device(s) established as a safety precaution and work to be carried on the Isolator / disconnector:-

- Work is permitted on the isolator / disconnector providing that the **Earthing Device** is not compromised during the course of the work. A **Senior Authorised Person** shall produce a written risk assessment identifying the appropriate control measures, e.g. risk of mobile access equipment coming into contact with **Earthing Device**.

There may be situations where certain minor work can be carried out under strict controlled conditions, provided that the risk of injury is prevented and the integrity of the **Point of Isolation** shall not be compromised. An example of this is where an **HV** isolator is a safety precaution and it is essential to carry out minor wiring work in the mechanism box on the **LV** wiring.

In order to satisfy the requirements of the Electricity At Work Regulations, there are a number of key issues that should be adopted:-

- a) The planning process should where possible seek to avoid this situation occurring.
- b) It should be the exception rather than the norm.
- c) The work shall not affect the integrity of the safety precaution. How this is achieved must be clearly identified in a safe system of work.
- d) If the **Point of isolation** is restored, it should be possible for the minor work to continue safely.

Safety Rule

The Eight Basic
Safety Rules
R3.3 to R3.6

- R3.3 When work on the **HV Equipment** does not require the removal of **Primary Earth(s)** a **Permit for Work** shall be issued.
- R3.4 When work is to be carried out on **HV Equipment**, and it is essential to restore motive power for certain **Approved** work, during the period that the **Permit for Work** is in force, the following additional precautions shall be applied:-
- An **Approved** restoration of motive power (ROMP) procedure shall be provided and observed. This shall specify the requirements necessary to maintain **Safety from the System** whilst motive power is restored.
 - No other **Permit for Work** or **Sanction for Work** shall be in force on the same item(s) of **HV Equipment**.
- R3.5 When work on **HV Equipment** requires the removal of **Primary Earth(s)** a **Sanction for Work** shall be issued. Provided **Safety from the System** is maintained the following additional precautions shall be applied:-
- The **Primary Earth(s)** that may be removed or replaced during the work shall be identified.
 - Essential supplies which may be restored to enable the work to take place shall be defined in an **Approved** restoration of motive power (ROMP) procedure.
 - Work shall be carried out in accordance with an **Approved Sanction for Work** (SFW) procedure.
 - No **Permit for Work** or other **Sanction for Work** shall co-exist within the same zone established by **Point(s) of Isolation** except under an **Approved** procedure.
- R3.6 When **Danger** from **Charged** conductor(s) could arise during the course of work, **Drain Earth(s)** shall be applied. Any portable **Drain Earths** shall be issued with the appropriate **Safety Document(s)** together with an **Earthing Schedule** which shall specify the **Drain Earth** requirements for each stage of the work.

Guidance

The Eight Basic
Safety Rules
R3.3 to R3.4

R3.3 There is no requirement for the OHL **Permit for Work** to be exclusively used for OHL work. When substation or cable work requires that **Circuit Identification Colour / Symbols** are quoted or there is a need to issue **Flags / Wristlets** the **OHL Permit for Work** may be the most appropriate **Safety Document** to be used. Authorisation under Management Procedure NSI 4 is not required by a **Senior Authorised Person** to use an **OHL Permit for Work**.

R3.4 A **Permit for Work** can be issued which allows for the safe restoration of motive power supplies during the course of work when these are essential to complete the work. Examples of such work are the maintenance of tap changers and motor driven disconnectors for which the restoration of **LV** supplies is required.

If work requires transfer of a **Safety Document** between different **Competent Person(s)** and the ROMP procedures do not apply to all the work, the following process can be followed to allow for one **Permit for Work** to be issued controlling all the different work activities. (e.g. **Permit for Work** for scaffolding prior to maintenance of a circuit breaker and then de-scaffolding following the maintenance).

i. Once the **Permit for Work** has been prepared and consented to, the **Senior Authorised Person** issues the **Permit for Work** and ROMP procedure and all associated items to himself.

ii. The ROMP items are then placed into a separate **Key Safe**, the **Key Safe** shall where practicable be **Locked** with a **Control Key** and a **Key Safe Key** shall be issued to the **Competent Person**.

iii. The **Senior Authorised Person** will complete a Status of Transfer document, listing the ROMP items and their location, details of the **Key Safe** used and location of the **Key Safe Key**.

i) Section 2 of the Status of Transfer form shall state, "No ROMP activities to be undertaken". Items listed are withheld for the duration of the non ROMP activities. Safe custody to be maintained by the **Senior Authorised Person**.

ii) Section 3 of the Status of Transfer form shall state, "ROMP supplies isolated and secured in **Key Safe** No (key No...)".

iv. The **Permit for Work** (minus the ROMP items), the **Key Safe Key** and the Status of Transfer document can then be transferred to a **Competent Person** (such as a scaffolder or painter) for the non-ROMP work to be carried out.

v. Upon completion of the non-ROMP work the **Competent Person** transfers the **Permit for Work** back to a **Senior Authorised Person**.

vi. For the ROMP work to be carried out the **Senior Authorised Person** transfers the **Permit for Work** to a **Competent Person** authorised to hold ROMP's along with the ROMP items from safe custody.

vii. On completion of the ROMP work the **Competent Person** transfers the **Permit for Work** to a **Senior Authorised Person**, who if necessary will place the ROMP items back into safe custody and transfer the **Permit for Work** to a non-ROMP authorised **Competent Person** to complete the non ROMP related work. Ensuring that the Status of Transfer document is completed and communicated at each stage of the transfer process. **The completed Status of Transfer forms shall be retained with the Safety Document.**

When the work activity requires the restoration of motive power supplies, the recipient of the **Permit for Work** shall provide **Personal Supervision**.

Guidance

The Eight Basic
Safety Rules
R3.5 to R3.6

R3.5 There shall be no undue delay between completing the Preparation section and Issue section of a **Sanction for Work**. However, there will be a period of time necessary to carry out the setting to work process, i.e. between the preparation and issue of the **Safety Document**.

The recipient of a **Sanction For Work** shall be a **Competent Person** trained and competent to carry out the work. They shall be appointed under Management Procedure NSI 9 – “Testing High Voltage Equipment”. They shall provide **Personal Supervision** for the testing and ensure that **Safety from the System** is maintained during the course of work. Switching carried out under the **Sanction for Work**, other than by the recipient, should be recorded locally in accordance with the requirements of Management Procedure NSI 1 – “Operational and Safety Switching”.

b) The **Safety Keys** for restoring essential supplies will be issued with the **Sanction for Work**. The recipient shall maintain **Safety from the System** by adhering to the relevant ROMP procedure.

c) For work, which requires the removal of **Primary Earths**, an **Approved Sanction for Work** procedure shall be written. This may take the form of national generic procedures for routine testing or a more specific local procedure for a specific test.

d) In special circumstances an exception is permitted if a written procedure has been agreed by all parties concerned and **Approved** for use.

R3.6 Under certain circumstances it will not be possible to plan the stage by stage application of **Drain Earths**. Alternative arrangements shall be written and communicated prior to the work starting. This could include stating on the **Earthing Schedule** “to be applied under the **Personal Supervision** of a **Senior Authorised Person**”. In these circumstances the **Senior Authorised Person** shall be the recipient of the **Safety Document** for that stage of the work. The recipient of the **Drain Earths** and associated **Earthing Schedule** shall be **Competent Person** to Management Procedure NSI 2 – “Earthing High Voltage Equipment”. This appointment allows them to apply / remove **Drain Earths** in accordance with the **Earthing Schedule**.

Normally **Drain Earths** will be applied / removed within a demarcated work area by the **Competent Person** holding the safety document. If there is a requirement to apply / remove **portable Drain Earths** outside of a demarcated work area this must be undertaken under the **Personal Supervision** of a **Senior Authorised Person** and the requirement recorded on the **Earthing Schedule**.

For Overhead Line work the equivalent authorisation for the application / removal of **Drain Earths** is Management Procedure NSI 4 – “Work on or near to Overhead Lines”.

If **Drain Earths** are required and the **Safety Document** needs to be transferred to a **Competent Person** who does not have the authorisation to apply or remove **Drain Earth(s)**, the Status of Transfer form can be used stating “**Drain Earth(s)** are not to be interfered with”. The **Earthing Schedule** shall be placed in Safe Custody and managed as the ROMP Process (R 3.4 Guidance).

Bonding of scaffolding and similar structures to earth using Field Equipment Earths does not require the issue of an **Earthing Schedule**.

Guidance

The Eight Basic
Safety Rules
R3.6 Cont.

Where **High Voltage (HV) Live** Line techniques are being used under **Permit for Work** conditions the work method, tools and equipment are such that the **Danger** from **Charged** conductor(s) will not arise and therefore the application of locally applied **Drain Earths** will not be required. It is sufficient in Section 2 of the **Permit for Work** under "Further precautions to be taken during the course of the work to avoid **System** derived hazards" to write the words "Live Line Working Techniques and Procedures shall be followed at all times".

Safety Rule

The Eight Basic
Safety Rules
R4

R4 Safety Precautions for Work on or Near to Low Voltage Equipment

- R4.1 When work is to be carried out on or near to **LV Equipment**, a **Senior Authorised Person** shall assess the means of achieving **Safety from the System**. When **Safety from the System** can be achieved by limiting the work or work area, instructions clearly defining the limitations shall be given. When the **Senior Authorised Person** decides it is necessary to confirm these instructions in writing, he shall consider issuing a **Limited Access Certificate**.
- R4.2 When **Safety from the System** cannot be achieved by limiting the work or work area, work on or near to **LV Equipment** shall where reasonably practicable be carried out with the **LV Equipment Dead**. The following safety precautions shall be applied:-
- The **LV Equipment** shall be identified by either the Planning Process or the **Senior Authorised Person**, and the **Control Person (Operation)** shall prepare, then release it from **Operational Service**.
 - The **Control Person (Safety)** shall ensure that the **LV Equipment** is **Isolated** and that **Point(s) of Isolation** are established for the work.
 - The **Senior Authorised Person** shall ensure **Danger** has been excluded from **Charged** conductors.
- R4.3 A **Senior Authorised Person** shall assess the work required on or near to the **Dead LV Equipment** and decide whether it shall be carried out under:-
- A **Permit for Work**, or
 - RAMS and Personal Supervision**, or
 - RAMS only**
- R4.4 When it is unreasonable for the **LV Equipment** to be made **Dead**, suitable precautions shall be taken to avoid **Danger**. A **Senior Authorised Person** shall assess the work required on or near to the **Live LV Equipment** and decide whether it shall be carried out under:-
- A **Certificate for Live LV Work**, or
 - Precautions specified in a Management Procedure

Guidance

The Eight Basic
Safety Rules
R4.1 to R4.3

R4 Safety Precautions for Work on or Near to Low Voltage Equipment

R4.1 When a contractor's risk assessment adequately covers **Safety from the System** aspects, there is no need for the **Senior Authorised Person** to record a separate **Safety from the System** risk assessment. In this case, the SAP may annotate the contractor's RAMS "This documented safe system of work when implemented is sufficient to achieve **Safety from the System** from National Grid's electricity transmission system".

When the **Senior Authorised Person** decides it is necessary to confirm these instructions in writing, he shall, record the assessment and controls to be applied in AMBP 311 RAMS. Where the RAMS controls all **Safety from the System** hazards there is no requirement to issue a **Limited Access Certificate**.

Where contractors are carrying out work near to **Equipment** and the means of achieving **Safety from the System** is by limiting the work or work area, a **Senior Authorised Person** shall confirm these instructions in writing by the issue of a **Limited Access Certificate**. The only exception to this requirement is where the identified work, and / or work area as detailed and controlled in the risk assessment and method statements are limiting in their own right, thus ensuring there is no risk from the **System**. An example of this would be risk assessment and method statement detailing the painting of a blockhouse door from ground level.

R4.2 Work on or near **Live** conductors should rarely be permitted. Experience in the past has shown that many accidents occur when persons are working on **Equipment** which could have been **Isolated**. In most cases adequate planning and work programming will allow such jobs to be carried out with the **Equipment Dead**.

R4.2a In the majority of cases the **Control Person (Operation)** and the **Control Person (Safety)** for **LV Equipment** will be the same person.

R4.2c Guidance on excluding **Danger** from **Charged** conductors is given in Management Procedure NSI 5 – "Cable Systems".

R4.3 Management Procedure NSI 12 – "Low Voltage Equipment" provides further guidance when working on or near to **Dead LV Equipment** this includes the decision process with regards to **Permit for Work, Personnel Supervision, or RAMS only**.

R4.3b A **Senior Authorised Person** will provide **Personal Supervision following the risk assessment process**.

R4.3c When a **Senior Authorised Person** decides to set themselves to work, the risk assessment process must be to the same standard of setting a third party to work.

Guidance

The Eight Basic
Safety Rules
R4.4

R4.4 Where it is unreasonable to make the **LV Equipment Dead**, and where **Danger** may arise, work on or near to **Live LV Equipment** is only allowed provided all three of the following conditions are satisfied;

- i. It is unreasonable in all the circumstances for **LV Equipment** to be **Dead**: - There are some circumstances where it is unreasonable to make **Equipment Dead** because of the difficulties it would cause e.g. commissioning a control panel, fault finding, working on a battery or function tests.
 - ii. It is reasonable in all the circumstances for a person to be at work on or near **LV Equipment** while it is **Live**: - Before allowing a person to be at work on or near to **Live LV Equipment**, a risk assessment shall be carried out whereby the economic and operational factors of leaving the **Equipment Live**, are evaluated against the risk to the person carrying the work out.
 - iii. Suitable precautions (including where necessary the provision of suitable protective equipment) are taken to prevent injury:- Consideration shall be given to adequate screening, competence of individuals, adequate work space and lighting, use of insulated tools, supply and use of PPE, and suitable emergency procedures.
- a) Guidance issued by the Health and Safety Executive against the Electricity at Work Regulations 1989 precludes the issue of a **Permit for Work on Equipment** that is still **Live**.
 - b) Management Procedure NSI 12 – “Low Voltage Equipment” clarifies that for particular **LV Equipment**, which presents a low risk due to low energy levels, e.g. 50 V DC telecommunications **Equipment**, work could be carried out under normal routine instructions. These could be detailed on a job specification or RAMS.

A **Certificate for Live LV Work** has been introduced to conform to this guidance. Risk Assessment may indicate that the person carrying out the **Live LV** work should be accompanied. A written procedure should be produced which shall include a method statement for the work.

When a **Senior Authorised Person** has assessed that there is a hazard, when working on **Dead LV Equipment**, from adjacent exposed **Live LV Equipment**, the **Live Equipment** shall where reasonably practicable be screened to remove the **Danger** and a **Permit for Work** shall be issued.

Management Procedure NSI 12 – “Low Voltage Equipment” clarifies the process for screening near to **Live LV Equipment**.

If the risk from the exposed **Live LV Equipment** cannot be adequately controlled by screening then a **Certificate for Live LV Work** shall be issued.

Safety Rule
The Eight Basic
Safety Rules
R5

R5 Safety Precautions for Work on or Near to Mechanical Equipment

- R5.1 When work is to be carried out on or near to mechanical **Equipment**, a **Senior Authorised Person** shall assess the means of achieving **Safety from the System**. When **Safety from the System** can be achieved by limiting the work or work area, instructions clearly defining the limitations shall be given. When the **Senior Authorised Person** decides it is necessary to confirm these instructions in writing, he shall consider issuing a **Limited Access Certificate**.
- R5.2 When **Safety from the System** cannot be achieved by limiting the work or work area, the following safety precautions shall be applied.
- a) The mechanical **Equipment** shall be identified by either the Planning Process or the **Senior Authorised Person**, and the **Control Person (Operation)** shall prepare, then release it from **Operational Service**.
 - b) The **Control Person (Safety)** shall ensure that the mechanical **Equipment** is **Isolated** and that **Point(s) of Isolation** are established for the work.
 - c) The contents of the mechanical **Equipment** shall be adjusted to a level which avoids **Danger**. Where drain valves are used they shall where practicable be **Locked** in the appropriate position.
 - d) Where **Danger** could arise from pressurisation, the mechanical **Equipment** shall be **Vented**. The emissions shall be dissipated so as to avoid **Danger**. Where reasonably practicable vents shall be **Locked** open.
 - e) Where internal access is required, and the residue of contents could cause **Danger**, the mechanical **Equipment** shall be **Purged**. The emissions shall be dissipated so as to avoid **Danger**. The **Equipment** shall be restored to atmospheric pressure when purging is complete.
 - f) Where **Danger** could arise from the release of stored energy, action shall be taken to contain, equalise or dissipate this energy safely.
 - g) Before work commences a **Permit for Work** shall be issued.
- R5.3 When work is to be carried out on mechanical **Equipment**, and it is essential to restore motive power for certain **Approved** work, during the period that the **Permit For Work** is in force, the following additional precautions shall be applied:-
- a) An **Approved** restoration of motive power (ROMP) procedure shall be provided and observed. This shall specify the requirements necessary to maintain **Safety from the System** whilst motive power is restored.
 - b) No other **Permit for Work** shall be in force on the same items of mechanical **Equipment**.

Guidance

The Eight Basic
Safety Rules
R5.1

R5 Safety Precautions for Work on or Near to Mechanical Equipment

R5.1 When a contractor's risk assessment adequately covers **Safety from the System** aspects, there is no need for the **Senior Authorised Person** to record a separate **Safety from the System** risk assessment. In this case, the SAP may annotate the contractor's RAMS "This documented safe system of work when implemented is sufficient to achieve **Safety from the System** from National Grid's electricity transmission system".

It is always preferable from the point of view of safety, that work on or near to mechanical **Equipment** should be carried out when that **Equipment** is: **Isolated**, drained, **Vented** and **Purged** as appropriate.

When the **Senior Authorised Person** decides it is necessary to confirm these instructions in writing, he shall, record the assessment and controls to be applied in AMBP 311 RAMS. Where the RAMS controls all **Safety from the System** hazards there is no requirement to issue a **Limited Access Certificate**.

Where contractors are carrying out work near to **Equipment** and the means of achieving **Safety from the System** is by limiting the work or work area, a **Senior Authorised Person** shall confirm these instructions in writing by the issue of a **Limited Access Certificate**. The only exception to this requirement is where the identified work, and / or work area as detailed and controlled in the risk assessment and method statements are limiting in their own right, thus ensuring there is no risk from the **System**. An example of this would be risk assessment and method statement detailing the painting of a blockhouse door from ground level.

Management Procedure NSI 17 – "Pressure Systems" details specific precautions for working on mechanical **Equipment**.

Fire Protection Systems.

Water Systems

The Senior Authorised Person shall ensure fire protection systems are **Isolated** before work commences if they cause **Danger**.

High pressure water spray (deluge) systems do not, themselves, cause **Danger**. Such systems may generally be left in service when persons enter or work in an area protected by a high pressure water spray system.

An occasion when such equipment shall be **Isolated** is when the operation of the system could cause additional **Danger** (e.g. working in close proximity to the nozzle, or the system may be accidentally operated during the course of the work).

Gas or Chemical Systems

The **Senior Authorised Person** shall ensure **Points of Isolation** are established prior to entry to an area which has an automatic fire protection system using gas or chemical suppressant.

Before entry into an area where a fire protection system has been discharged, the area shall be thoroughly checked and verified safe by the use of an oxygen meter. When entering the area the appropriate personal protective equipment shall be worn.

Examples of a gas or chemical system are:

CO2 - (Gas)

Innogen – (Chemical)

Guidance

The Eight Basic
Safety Rules
R5.2 to R5.3

R5.2 In the majority of cases the **Control Person (Operation)** and the **Control Person (Safety)** for mechanical **Equipment** will be the same person.

R5.2d It is not always possible to vent pressurised air systems to atmosphere prior to the issue of a **Safety Document**.

When pressurised air is trapped in pipe work and is required to be released, the **Senior Authorised Person** must vent where reasonably practicable by applying **Isolation** further back into the **System**, even if it requires taking out more of the air **System**. Where this is not reasonably practicable then Management Procedure NSI 17 – “Pressure Systems” shall be followed.

R5.3a Management Procedure NSI 32 – “Register of Approved Procedures” identifies all associated **Approved** Procedures.

Safety Rule

The Eight Basic
Safety Rules
R6

R6 Operation of Equipment

R6.1 The operation of **Equipment** to achieve **Safety from the System** shall never involve pre-arranged signals or the use of time intervals.

Guidance

The Eight Basic
Safety Rules
R6

R6 Operation of Equipment

R6.1 This Safety Rule applies only when **Equipment** is being operated towards achieving **Safety from the System**, e.g. establishing **Point(s) of Isolation**. It is not intended to prevent normal operation of **Equipment** that sometimes necessitates pre-arranged instructions, e.g. switching shunt reactors or changing compressor running arrangements, this is considered normal routine switching.

Safety Rule

The Eight Basic
Safety Rules
R7

R7 Demarcation of Work Areas

R7.1 The work area shall be defined clearly. Where necessary it shall be protected physically to prevent **Danger** to individuals in the area from **System** hazards near to the work area.

Guidance

The Eight Basic
Safety Rules
R7.1

R7 Demarcation of Work Areas

R7.1 The work area shall be clearly defined so that all persons can easily recognise the working area. Management Procedure NSI 6 – “Work and Demarcation” in Substations gives particular requirements on the demarcation of work and hazard areas in **HV** substations. This also includes work areas for **LV** and mechanical **Equipment**.

The **Senior Authorised Person** will define the limits of the work area. This shall be completed after safety precautions have been established but before the issue of the **Safety Document**.

Guidance

The Eight Basic
Safety Rules
R7.1 Cont.

To ensure no encroachment within **Safety Distance** the demarcated work area shall be planned to be as small as reasonably practicable, ensuring it is large enough to accommodate any materials or plant required to carry out the work. Where reasonably practicable a demarcated work area shall be limited to one **Working Party** at any one time. Where more than one **Working Party** is required, this shall be addressed at the planning stage and multiple smaller demarcated work areas or staggered working arrangements be considered. If more than one **Working Party** is set to work in a single demarcated work area then the **Senior Authorised Person** shall ensure adequate coordination between each **Working Party** is established to achieve a Safe System of Work. During the work it is each **Competent Person's** responsibility to ensure adequate co-ordination is maintained. It may not be necessary to demarcate all equipment identified in Section 1 of the **Safety Document** e.g. when a circuit has been taken out of service for proximity working.

The **Competent Person** in charge of the **Working Party** is responsible for controlling access to the work area. Where more than one **Working Party** is set to work in a single demarcated work area, access is the joint responsibility of all **Competent Person's** in charge of a **Working Party**.

Once instructed by a **Senior Authorised Person** an appropriately authorised **Competent Person** can remove demarcation equipment after Clearance of the **Safety Document**.

For overhead lines the work area shall be clearly defined so that all **Personnel** can easily recognise the working area. Management Procedure NSI 4 – “Work on or Near High Voltage overhead lines” details the requirements of this process. The demarcation can only be put in place after the Issue of the **Safety Document** and removed before the Clearance of the **Safety Document**.

At shared user sites, demarcation arrangements will be agreed between the relevant parties **Senior Authorised Person(s)**. This will normally be to use the demarcation of the Company carrying out the work. This is to ensure that the **Working Party** carrying out the work is familiar with the demarcation involved.

When commissioning on **LV** panels, consideration shall be given to using notices on **Live** circuits (e.g. panels in service) to demarcate them adequately from those being worked on. This is to ensure staff understand that the panels are still in service and **Danger** could exist.

Safety Rule

The Eight Basic
Safety Rules
R8

R8 Identification of Equipment

R8.1 Work shall only be permitted to start on **Equipment** that is readily identifiable. Where necessary, a means of identification shall be fixed to the **Equipment** and remain effective throughout the course of the work.

Guidance

The Eight Basic
Safety Rules
R8

R8 Identification of Equipment

R8.1 **Equipment** shall be readily identifiable. It may be necessary to provide temporary identification to comply with this Safety Rule. This shall be assessed and controlled by a **Senior Authorised Person**.

When **Equipment** is not readily identifiable, definable point(s) will be required e.g. for a section of busbar between two support post insulators with the support post insulators temporarily identified.

The temporary identification could be, for example, a hand written label or a plasticised pre-printed sheet. The **Senior Authorised Person** assessing the suitability of the label to ensure Rule R8 is satisfied must take into consideration the time period the label will be in place and the general environmental conditions the label will be subject to.

Safety Document Procedures

Safety Rule Safety Document Procedures P1

P1 General

- P1.1 This part of the Rules gives outline procedures for the Preparation, Issue, Transfer, Clearance and Cancellation of **Safety Document(s)**.
- P1.2 All **Personnel** involved in these procedures shall be trained in their roles and responsibilities.
- P1.3 All cancelled copies of **Safety Document(s)** and supplementary documentation shall be retained for 3 years.

Guidance Safety Document Procedures P1

P1 General

- P1.2 The formal appointment of **Personnel** under the Safety Rules is laid down in Management Procedure NSI 30 – “Appointment of Persons”. This clarifies the appropriate levels of training and assessment required for the different levels of authorisation.
- P1.3 All documents shall be grouped together and retained at the **Location** of issue. Overhead line documents will be retained at an overhead line office location. **Safety Document(s)** are to be retained for 3 years from issue. This includes other supplementary documentation: Working Party Register, **Earthing Schedule**, and Risk Assessments.

Note: T Cards can be discarded.

Safety Rule Safety Document Procedures P2

P2 Application

- P2.1 A **Safety Document** shall be issued to a **Competent Person**, and shall be personally retained. He shall keep the **Safety Document, Key(s)**, and any supplementary documentation issued, in safe custody.
- P2.2 The maximum number of **Safety Document(s)** that may be held by a **Competent Person** at any one time is 3.

Guidance

Safety Document
Procedures
P2

P2 Application

P2.1 The **Safety Document(s)** and supplementary documentation shall be personally retained by the recipient.

Recipients should be provided with the means for retaining **Safety Document(s)** and attachments in their personal possession. Personal possession means to have the documentation available at the point of work in order to be able to refer to it if required. Safe custody means to keep the **Safety Document** and associated supplementary documents dry and readable and ensures all items received cannot be lost or interfered with, e.g. locked in the vehicle of the **Competent Person**.

The recipient of a **Safety Document** is responsible for ensuring that all aspects of safety are maintained throughout the course of the work. This includes **General Safety** responsibilities as detailed in Management Procedure – “Work and Work Execution”.

P2.2 The **Competent Person** shall provide **Local Supervision** to the **Working Party** linked to all **Safety Document(s)** held. In addition the level of **Supervision** shall be enhanced to **Personal Supervision** when required by these rules and supporting procedures or when a **Senior Authorised Person** requires, e.g. restoration of motive power.

If more than one **Safety Document** is held simultaneously, the **Competent Person** shall ensure safety is maintained in accordance with the safe system of work.

Safety Rule

Safety Document
Procedures
P3

P3 Safety Precautions

P3.1 Safety precautions applied / removed to achieve **Safety from the System** shall be the responsibility of an **Authorised Person** or in the case of portable **Primary Earths** a **Senior Authorised Person**, under the instructions of a **Control Person (Safety)**. They shall both complete a record of the safety precautions taken.

P3.2 The **Keys** securing the safety precautions shall be placed by the **Authorised Person** in a **Key Safe** which shall be **Locked** by a **Key Safe Key**. The **Key Safe Key** shall be retained in safe custody in accordance with a Management Procedure.

P3.3 The **Senior Authorised Person** shall where reasonably practicable secure the **Key Safe** by using the **Control Key** prior to **Consent** of the **Safety Document**.

P3.4 The **Senior Authorised Person** shall prepare the **Safety Document** obtaining from the **Control Person (Safety)**, confirmation of the safety precautions taken.

Guidance

Safety Document
Procedures
P3.1 to P3.4

P3 Safety Precautions

P3.1 The process for controlling switching activities is laid down in Management Procedure NSI 1 – “Operational and Safety Switching”. Management Procedure NSI 2 – “Earthing HV Equipment” clarifies the appropriate levels of competence that can assist in the application of safety precautions.

For **LV** and mechanical switching where the **Senior Authorised Person** acts as the **Authorised Person** to establish safety precautions prior to preparation of a **Safety Document**, the detailing of safety precautions on the **Safety Document** will be the record of Safety Precautions established.

When a physical disconnection is used as a safety precaution, consideration shall then be given as to the most appropriate method to lock and caution the disconnection to establish a **Point of Isolation**.

For Overhead Line disconnections

Lock all access points at the ACD level of the tower involved using safety locks and fix **Caution Notices** just above ACD level.

Alternatively:

- Chain, lock and caution at the immediate point of the disconnection i.e. at the cross-arm.

Or

- Chain and lock at the immediate point of disconnection i.e. at the cross-arm and caution at the junction of the associated cross-arms and tower body.

Any removed conductors should be securely stored at a remote location, e.g. Substation, OHL office, NG / Contractors Site Office / Yard, etc.

For Substation Disconnections

Where practicable, caution all disconnected points at the point of disconnection on the **Dead** side of the **Equipment** and lock away the busbars / conductors removed to prevent access to them. The **Caution Notice** can be applied to the busbar bolted connection whilst the **Safety Document** to remove the busbar is in force. This lock key becomes the **Safety Key** and will be locked in a **Key Safe** for safe custody.

P3.2 The Management Procedure NSI 1 – “Operational and Safety Switching” details how to manage **Safety Keys**. As the **Safety Keys** are associated with a **Point of Isolation** they shall be retained in safe custody in a **Key Safe**. The preferred option is that the **Safety Key** can be located at any nearby substation associated with the circuit. If this principle cannot be adopted the **Safety Key** can be secured at some other location where a **Key Safe** is available, on a permanent or temporary basis, such as an OHL office or a Project Site Office.

In cases where TP153 – “Work Co-ordination and Management”, is not being implemented it is best practice for dialogue between **Senior Authorised Persons** involved in work across interface points to take place prior to commencing work that is likely to have an impact on other working parties.

P3.4 The **Control Person (Safety)** is responsible for providing details of the safety precautions taken to the **Senior Authorised Person**.

It is the responsibility of the **Senior Authorised Person** preparing the **Safety Document** to ensure that the safety precautions are adequate for the work.

Safety Rule
 Safety Document
 Procedures
 P4

P4 Preparation of Safety Documents

P4.1 The **Senior Authorised Person** preparing a **Safety Document** shall enter the following details as appropriate:-

- a Unique **Safety Document** number
- b **Location**
- c Identification of **Equipment** to be worked on or near to including where appropriate the **Circuit Identification**
- d Work to be done
- e Limits of the work or the work area
- f Hazards that have been assessed for **Live LV** work
- g Precautions to be taken for **Live LV** work
- h Safe system of work for **Live LV** work
- i Precautions taken to achieve **Safety from the System**
- j Precautions that may be varied by the recipient
- k **Control Person (Safety)** consenting to the preparation
- l **Key Safe** number
- m Preparation signature, time and date

Guidance
 Safety Document
 Procedures
 P4.1

P4 Preparation of Safety Documents

P4.1 The **Senior Authorised Person**, shall where reasonably practicable, before preparing any **Safety Document** check the Substation or Overhead Line Status Board for any other **Safety Documents** issued which may prevent the issue of another **Safety Document** on the same piece of **Equipment**, e.g. appropriate **Safety Document** with associated ROMP, appropriate **Safety Document** with associated electrical testing as per Management Procedure NSI 9 – “Testing High Voltage Equipment”.

Where the electronic **Safety Document** template is used, a new document shall be created each time from the appropriate controlled template.

The **safety document** shall be printed on the appropriate coloured paper / card:

Permit for Work	Pink
Sanction for Work	Green
Limited Access Certificate	Blue
Certificate for Live LV Work	White

The copy of the **Safety Document** shall be printed on White Paper / Card.

Where a **Safety Document** is prepared in conjunction with a **Control Person (Safety)** for the **HV System**, the **Safety Document** shall be printed before contacting the **Control Person (Safety)**. The printed **Safety Document** shall be used to dictate to the **Control Person (Safety)** the actions taken to achieve **Safety from the System**.

For business continuity purposes pre-printed blank **Safety Documents** shall be available at each **Location** which will then be completed by hand. Where reasonably practicable a copy shall be made of the hand written **Safety Document**. This can be done by copier, fax or photograph depending on the location facilities. Where a copy is made this shall be clearly identified with the words “COPY”.

Guidance

Safety Document
Procedures
P4.1 Cont.

It is of great importance that the **Senior Authorised Person** (both substation and overhead lines) communicate with other parties that may be affected by the issue of the **Safety Document**. It is vital that no other documents that are in force are affected by the issuing of the **Safety Document**.

Alterations to **Safety Documents** should wherever possible be avoided. They are not acceptable in Section 1. Alterations to other Sections shall be completed by the obliteration of the complete word or item to be changed. All changes shall be initialled by the **Senior Authorised Person** preparing the **Safety Document**.

If any mistakes are identified after the **Safety Document** has been declared as prepared or issued, then the **Safety Document** shall be cleared and then cancelled with appropriate **Control Person (Safety)** and a new **Safety Document** prepared.

- b) The **Location** section on the document will reflect the name of the location on site records, operation diagrams, site responsibility schedules or Technical Data Sheets.
- c) Work shall only be carried out on the Equipment identified in Section 1 of a Safety Document. Where a circuit is required to be switched out due to its nearness to non items of Equipment to achieve Safety from the System to enable the work to be carried out, the following information shall be recorded:-

If an outage is required to work on items which are not **Equipment** e.g. a block house roof, tree, items of plant (NSI 33 Definition) etc. then the item of **Equipment** on which the outage is required shall be quoted in Section 1 of the **Safety Document**.

In order for the NOC to utilise their safety management system definable point(s) on the **System** shall be identified e.g.

Location: Hams Hall 400 kV Substation

Equipment Identification: Hams Hall Feckenham circuit down leads located between terminal tower 4DA and line Isolator X403.

Work to be Done: Dismantle lighting column L9 in proximity to down leads

If an outage is required to work on items of **Equipment** and an outage is required on other **Equipment** due to its proximity, then both items of **Equipment** shall be quoted in Section 1 of the **Safety Document**.

In order for the NOC to utilise their safety management system definable point(s) on the **System** shall be identified e.g.

Location: Ratcliffe 400 kV Substation

Equipment Identification: Staythorpe Yellow Phase CVT, Willington East 2 Circuit between Willington East 2 through wall bushings and Willington East 2 Cable Sealing ends.

Work to be done: To remove and replace Staythorpe Yellow Phase CVT, using a crane in proximity to Willington East 2 Circuit.

The definable point(s) and **Equipment** identification must reflect the wording on **Equipment** labels, operational diagrams or technical data sheets for Substations and Overhead lines as appropriate. Where this is not possible a temporary identification should be agreed with the NOC and label fitted in accordance with Safety Rule R8.

Guidance

Safety Document
Procedures
P4.1c Cont.

Where third party circuits are involved in these issues then the requirements of Management Procedure UKBP SE 301 'Managing Safety Interfaces' shall be followed.

There is no requirement to include all **Equipment** within a demarcated work area in Section 1 '**Equipment** Identification'. All items of **Equipment** that are going to be worked on shall be included.

No item of **Equipment** specified in Section 1 to be worked on '**Equipment** Identification' can be quoted in Section 2 'Precautions to be taken to achieve **Safety from the System**' as a safety precaution except as detailed below:

This procedure allows certain **Equipment** to be specified in both Section 1 and Section 2 of a **Permit for Work**. This is only to be implemented for the application or removal of portable **Primary Earth(s)** to the high level busbars where infringement or possibly infringement of **Safety Distance** to the associated lower level busbar and busbar disconnector, which is also a safety precaution (locked closed).

Procedure:

1. **Point(s) of Isolation** shall be established to create an **Isolated** zone encompassing the disconnector and the associated high and low level busbars.
2. **Primary Earth(s)** shall be applied to the low level busbars adjacent to and as close as reasonably practicable to the disconnector. These earths shall be quoted as a safety precaution in Section 2 of the **Permit for Work**. These **Primary earths** may be fixed or portable **Primary Earth(s)**.
3. The **Primary Earth(s)** to be applied to the high level busbars shall be applied under a **Permit for Work**. The high level busbar shall be initially **Earthed** by either:
 - A Fixed **Earthing Device** applied to the high level busbar at another location on the busbar, or
 - An **Earthing Device** applied to the busbar through the Bus Coupler or Bus Section.
4. The disconnector (as identified in 2 above) shall then be closed and locked. This will ensure that there are **Primary Earth(s)** within 9 metres of the high level busbars adjacent the disconnector.
5. A **Permit for Work** shall be issued for the application or removal of portable **Primary Earths** to the high level busbar. No infringement of **Safety Distance** shall occur to **Equipment** that is 9 metres beyond the **Primary Earth(s)** applied to the low level busbars.
See Figure P4.1c

Guidance

Safety Document
Procedures
P4.1 Cont.

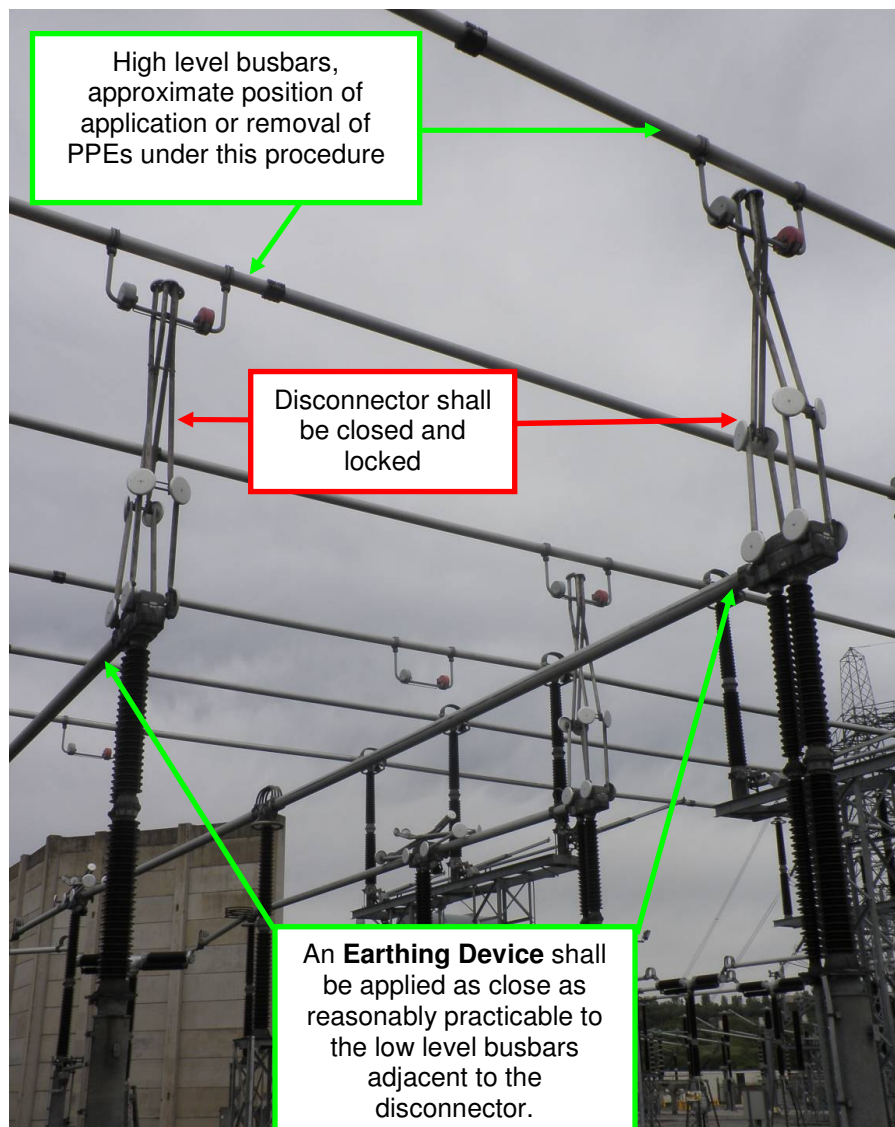

Figure P4.1c - Establishment of Safety Precautions to apply Earthing Devices to High Level Busbars

Isolators and VT secondary supplies that are **Points of Isolation** cannot be specified in Section 1 of the **Safety Document** until the **Point of Isolation** is rendered operative.

A fixed **Earthing Device** specified in Section 1 '**Equipment Identification**' may also be quoted for use on an Earthing Schedule.

Guidance

Safety Document
Procedures
P4.1 Cont.

P4.1i If a **Senior Authorised Person** is dealing direct with an External Company **Control Person**, and no RISSP is involved, safety precautions have been carried out by the External Company and a proof of isolation and earthing certificate is supplied. Reference to the proof of isolation and earthing certificate may be made in Section 2 of the **Safety Document**. A copy of the certificate is to be attached to the **Safety Document** to enable the isolation and earthing to be identified by the **Senior Authorised Person/Competent Person**.

After the **Senior Authorised Person** has prepared the **Safety Document** he will complete:-

- (a) The relevant **Safety Document** T Card and place it into the appropriate slot stating on the reverse in the recipient column the words "in safe custody" instead of current recipient if **Safety Document** is not to be issued immediately.
- (b) The record of **Safety Document** details on the back of the relevant POI/Earthing/RISSP T Card.

The separation of the Preparation and Issue and Receipt Sections of 'the **Permit for Work** and **Limited Access Certificate** enables the two processes to be completed by **Senior Authorised Persons** at different times. If the **Safety Document** is prepared but not to be issued immediately then the **Senior Authorised Person** will place the **Safety Document** into a **Card Safe** until it is ready for issue.

When there is insufficient space on the **Safety Document** a **Safety Document** continuation sheet may be used. If it is used then its unique number and number of associated **Safety Document** shall cross reference and be recorded on each document.

When **Drain Earths** are to be used the unique pre-printed number on the **Earthing Schedule** will be cross-referenced to the associated **Safety Document** and vice-versa.

Point(s) of Isolation Dependent on SF6

When isolation is gas density dependent, IGDD shall be recorded against the appropriate **Equipment** in Section 2 "**Point(s) of Isolation**" of the **Safety Document** and the **Isolated / to be Isolated** sections of the System State Certificate. Where IGDD **Isolation** is quoted on a **Safety Document** the telephone contact details for the issuing **Senior Authorised Person**, and **Competent Person** in charge of the work shall be recorded with the **Control Person (Safety)**.

Where RISSP's are exchanged the **Control Person (Safety)** will notify the Requesting Safety Co-ordinator that the **Point(s) of Isolation** is IGDD.

On receipt of a gas zone pressure alarm the **Control Person (Operation)** or NOC Response will inform the **Control Person (Safety)** who will ensure safety is maintained.

Guidance

Safety Document
Procedures
P4.1 Cont.

P4.1m Where a **Senior Authorised Person** wishes to quote **HV Equipment** that will be worked on or near to, that he does not have sufficient authorities for (e.g. NSI 4 authorised staff wishing to add NSI 2 **Equipment** for proximity), then the identified **HV Equipment** can be quoted on a **Safety Document** provided that:

- a) Prior to the issue of the safety document, the **Senior Authorised Person** (e.g. NSI 4 authorised) shall consult with a suitably authorised **Senior Authorised Person** with additional authorisations (e.g. NSI 2 authorised), to jointly develop a Safe System of Work.
- b) When the Safe System of Work has been agreed the **Equipment** shall be quoted in section 1 of the **Safety Document**, this shall be also be reflected in the **RAMS**.

Safety Rule

Safety Document
Procedures
P5

P5 Issue of Safety Documents

P5.1 The **Senior Authorised Person** issuing a **Safety Document** shall complete the Issue & Receipt Section recording as appropriate:-

- a) **Key Safe Key** number
- b) Number of **Safety Key(s)**
- c) **Earthing Schedule** number
- d) Number of portable **Drain Earth(s)**
- e) **Approved** Restoration of Motive Power Procedure number
- f) **Approved** Sanction For Work Procedure number
- g) Whether sketch provided
- h) **Circuit Identification** Colours/Symbols and number of flags and wristlets

P5.2 The **Senior Authorised Person** issuing a **Safety Document** shall, if required (see guidance for rule R3.4 and R3.6 for ROMP's and **Drain Earth(s)**), provide the **Competent Person** with the items listed in the Issue & Receipt Section.

P5.3 The **Senior Authorised Person** issuing a **Safety Document** shall ensure that the **Competent Person**:-

- (a) Reads and understands the **Safety Document** and the limits of the work, this should include, where reasonably practicable, a physical walk to see the safety precautions on site for the work being carried out.
- (b) Can identify the **Equipment** to be worked on.
- (c) Is conversant with any further precautions or procedures to be followed.

P5.4 The **Senior Authorised Person** shall sign the Issue & Receipt Section for the document to be formally issued.

Guidance

Safety Document
Procedures
P5

P5 Issue of Safety Documents

P5.1 When the work includes the removal of **Primary Earths**, the **Sanction for Work** will be issued to a **Competent Person** who has the authority to carry out the work detailed in the **Approved** procedures. There shall be no undue delay between the completion of the Preparation Section and Issue Section of a **Sanction for Work** and a **Certificate for Live LV Work**. However, there will be a period of time necessary to carry out the setting to work process.

If the **Safety Document** is associated with testing **HV Equipment**, (Management Procedure NSI - 9 "Testing High Voltage Equipment"), then no other **Safety Document** shall be issued on the same piece of **HV Equipment** or any other **HV Equipment** which could be affected by such testing.

P5.1d Existing **Primary Earth(s)** to be Declared as **Drain Earth(s)**

Verbal Request (SAP)	At (Location and voltage) on (circuit) request Primary Earth(s) applied at (position of earths) to be declared as Drain Earth(s)
Logged Confirmation (CP(S)1)	Written confirmation that at (Location and voltage) on (circuit) Primary Earth(s) applied at (position of earths) are declared as Drain Earth(s)

Example

At Kitwell 132 kV S/S
On SGT1 circuit

Confirmation that **Primary Earth(s)** applied adjacent to Earth Switch 181 have been declared as **Drain Earth(s)**.

Control Person (Safety) shall ensure that the **Primary Earth** is not quoted on any **Safety Document(s)** or Technical Limitation.

Control Person (Safety) shall remove the safety precaution from the IEMS. Where a fixed **Earthing Device** is to be used as a **Drain Earth** on an **Earthing Schedule** and quoted on a **Safety Document**, this shall be identified on the IEMS.

Control of the **Drain Earth(s)** are now the responsibility of the **Senior Authorised Person**, who shall immediately prepare and issue another **Safety Document** with an associated **Earthing Schedule**, as the **Drain Earth(s)** are still applied to **Equipment**.

If a new **Safety Document** cannot be issued immediately, to ensure control of the **Drain Earth(s)** a Technical Limitation shall be issued, which shall remain in force until a **Safety Document** is issued.

If the **Drain Earth(s)** were previously portable **Primary Earth(s)**, the **Senior Authorised Person** shall remove the **Primary Earth** labels.

Guidance
Safety Document
Procedures
P5.2 to P5.3

P5.2 The **Safety Documents** and supplementary documentation shall be personally retained by the recipient.

P5.3 The **Competent Person** also needs to fully understand all aspects of **General Safety** established for the work.

P5.3(a) For Substation work: when **Safety Documents** are being issued, it is reasonably practicable for the **Senior Authorised Person** to carry out a physical walk and identify the applicable safety precautions including **Points of Isolation, Earthing** and any demarcation used on site to the **Competent Person** for the work being carried out.

For OHL work involving the down leads or down droppers when **Safety Documents** are being issued, it is reasonably practicable for the **Senior Authorised Person** to carry out a physical walk and identify the applicable safety precautions including **Points of Isolation, Earthing** and any demarcation used on site to the **Competent Person** for the work being carried out. In some cases it may be desirable for a Substation **Senior Authorised Person** to assist with this Process. If the work does not involve access to the down leads or down droppers a physical walk of the substation to identify safety precautions will not normally be required.

Safety Rule
Safety Document
Procedures
P6

P6 Receipt of Safety Documents

P6.1 The **Competent Person** shall read and understand the requirements of the **Safety Document** and ensure they are conversant with the safety precautions established.

P6.2 The **Competent Person** shall sign the Issue & Receipt Section entering the time and date to formally receive the **Safety Document** and all associated items issued with the **Safety Document**.

Guidance
Safety Document
Procedures
P6.1

P6 Receipt of Safety Documents

P6.1 The **Senior Authorised Person** responsible for issuing a **Safety Document** shall hand over the **Safety Document** and any associated documents to the recipient at the time of issue. The associated documents shall include a **Working Party Register**, or in the case of National Grid staff the **Working Party Register** may be incorporated into the **AMBP 311 RAMS**

The **Senior Authorised Person** shall cross out on reverse of T Card any reference to "in safe custody" and record details of the current recipients of **Safety Document**, which shall then be placed in the appropriate position in the Substation Status Board. The copy of the issued **Safety Document** is to be retained on site.

Technical Data and Operation Diagrams should be available for reference by the **Competent Person** receiving a **Safety Document** to aid in the confirmation of the correct identification of **Equipment**.

Guidance

Safety Document
Procedures
P6.2

P6.2 Where members of the **Working Party** are set to work under a **Safety Document** the recipient of the **Safety Document** shall ensure that their names are entered on the **Working Party Register** and they are instructed in details of the work and relevant **Safety Document** and associated documents.

A single **Working Party Register** shall be used for each **Safety Document** which will be updated to include relevant information for different phases of the work (e.g. RAMS and **Working Party** information for scaffold erection, maintenance, scaffold dismantling). If the original **Working Party Register** becomes full, a second may be used attached to the original such that all information relative to the **Safety Document** is available.

Where more than one **Working Party** is set to work in a single demarcated work area under separate **Safety Documents**, **Working Party** members shall sign onto the **Working Party Register** associated with the **Safety Document** they are working under only.

Safety Rule

Safety Document
Procedures
P7

P7 Additional Work Subsequent to the Issue of a Safety Document

P7.1 A **Senior Authorised Person** shall assess the implications of additional work with regard to the **Isolated System** and **Safety from the System**.

P7.2 The **Senior Authorised Person** shall sign the Authorisation in Section 6 of the **Safety Document**.

P7.3 The **Competent Person** shall sign, time and date the acknowledgement in Section 6 of the **Safety Document**.

Guidance

Safety Document
Procedures
P7.1 to P7.2

P7 Additional Work Subsequent to the issue of a Safety Document

P7.1 The **Senior Authorised Person** assessing the work will carry out a risk assessment and record if significant risks are identified. The **Senior Authorised Person** shall ensure a safe system of work is developed.

P7.2 Additional minor work may only be authorised on the **Equipment** as described in Section 1 of the **Safety Document** provided the following do not change or alter:-

- (a) the **Point(s) of Isolation**
- (b) the **Primary Earths**

An example of minor work would be to replace a circuit breaker motor as a result of found on inspection during a maintenance process. For overhead lines this could be a replacement of a single insulator if within the scope of the **Safety Document**.

When **Drain Earths** are required for any additional minor work then an **Earthing Schedule** shall be issued and recorded in the additional work section of the appropriate **Safety Document**. Fixed **Earthing Device(s)** may be used on an additional **Earthing Schedule**.

Guidance

Safety Document
Procedures
P7.2 Cont.

Any additional method statements and risk assessments or changes to existing RAMS need to be included on the existing working party register and the **Competent Person** made fully aware of the new requirements.

For OHL Safety Documents the authorisation will be in Section 5.

Safety Rule

Safety Document
Procedures
P8

P8 Transfer of Safety Documents

P8.1 A **Safety Document** may be surrendered by the **Competent Person** completing Part 1 of the Transfer Record and the status of transfer form.

If the **Safety Document** is not to be transferred immediately it shall be secured in a **Card Safe** or given to a **Senior Authorised Person** who will hold the **Safety Document**.

P8.2 A **Safety Document** shall only be reissued by a **Senior Authorised Person**. Reissue shall be to the same standard as the original issue.

Guidance

Safety Document
Procedures
P8.1

P8 Transfer of Safety Documents

P8.1 When the **Competent Person** surrenders a **Safety Document**, he shall ensure that all members of the **Working Party** are withdrawn from the work area and that they sign off the **Working Party Register**.

Where a face to face meeting is not possible because any of the above persons are absent then one of the following actions shall be implemented:-

- i) **Senior Authorised Person** not available – The **Competent Person** surrendering the **Safety Document**, after completing the **Transfer Record** Section, shall also complete a Status of Transfer Record and then secure all **Safety Documents**, including any fuses, links and **Safety Keys** in a **Card Safe**. Where fuses, links etc. cannot fit into a **Card Safe**, they shall be secured and reference made to the secure location on the Status of Transfer form.
- ii) **Senior Authorised Person** available but not the new **Competent Person** – The **Competent Person** surrendering the **Safety Document**, after completing Section 7 (Transfer) shall also complete a Status of Transfer Record.

The **Safety Document** holder may then surrender the **Safety Document** and associated items to the **Senior Authorised Person**. The **Senior Authorised Person** shall retain all items surrendered in safe custody pending re-issue to the new **Competent Person**. The name of current recipient on reverse of Tee Card shall be crossed out and words "in safe custody" inserted.

P8.2 The **Senior Authorised Person** wherever possible will transfer the **Safety Document** with a face-to-face meeting with the **Competent Persons** surrendering the **Safety Document** and the new **Competent Person** receiving the **Safety Document**.

Guidance

Safety Document
Procedures
P8.2 Cont.

When a **Sanction for Work** or **Certificate for Live LV Work** is to be transferred by a **Senior Authorised Person** both the new recipient and person surrendering document shall be present at time of transfer. There shall be no delay in the transfer process. If it is not possible to have both **Competent Persons** present for the transfer process then the **Senior Authorised Person** can transfer the **Sanction for Work** to himself and re-issue at later time. The standard of issue must be as the original standard.

When a **Safety Document** is transferred to a new recipient the **Senior Authorised Person** shall also cross out the name of previous recipient or comments from relevant T card and record new name and company

If the **Safety Document** refers to isolation that is gas density dependant (IGDD) and the **Safety Document** is transferred then Part 2 of the Transfer Record of the **Safety Document** will contain the new telephone numbers. The **Control Person (Safety)** shall be informed of the changes.

Safety Rule

Safety Document
Procedures
P9

P9 Clearance of Safety Documents

P9.1 Before signing the Clearance Section of a **Safety Document** the **Competent Person** shall ensure that:-

- (a) All persons in his **Working Party** have been withdrawn from and warned not to continue to work on the **Equipment** concerned.
- (b) All items originally issued with the **Safety Document** are returned or accounted for as appropriate and all gear, tools, loose materials have been removed and guards, access doors replaced.
- (c) Any exceptions are recorded.

P9.2 If the **Safety Document** is not to be cancelled immediately it shall be secured in a **Card Safe**, or given to a **Senior Authorised Person** who will hold the **Safety Document** in safe custody.

P9.3 If there are nil exceptions when a **Safety Document** is cleared, the **Competent Person** shall state this on the **Safety Document**.

Guidance

Safety Document
Procedures
P9.1

P9 Clearance of Safety Documents

P9.1c An exception to be noted on the **Safety Document** is any deviation in the status of the **Equipment** or safety precautions established from that in which the **Equipment** was originally handed over to the **Competent Person** when the **Safety Document** was first issued.

Safety precautions may be established or removed on **Equipment** identified by a **Safety Document** they shall be recorded as an exception by the **Competent Person** in the clearance section of the **Safety Document**. The **Safety Document** shall be the record of the safety switching instruction between the **Senior Authorised Person** and the **Control Person (Safety)**.

Guidance

Safety Document
Procedures
P9.1 Cont.

Examples are:

- ROMP Supplies Restored
- **Primary Earth(s)** not re-applied following testing under a **Sanction for Work**
- **Drain Earth(s)** / earthing systems applied under a **Safety Document** to be declared as **Primary Earth(s)**
- Oil level or gas density abnormal due to ongoing work
- Timing covers left off circuit breakers
- Earth Switches reported back closed and locked.
- Disconnections reported back as **Point of Isolation**

Note: Isolators/ **Switch Disconnectors** in the open position cannot be quoted back as a **Point of Isolation** as an exception.

The **Senior Authorised Person** cancelling the **Safety Document** is responsible for ensuring any **HV** safety precautions listed by the **Competent Person** as exceptions are adequate to be utilised as **Point(s) of Isolation** or **Primary Earth(s)** when handed back to the **Control Person (Safety)**. For portable **Primary Earth(s)** reference NSI 2 or NSI 4.

Where **Drain Earth(s)** are applied in accordance with an **Earthing Schedule** and quoted as still applied in order to be used as a **Primary Earth(s)** in the **Safety Document** exception, the following process shall be followed:

Verbal Request (SAP)

At (**Location** and voltage) on (circuit) request Earth(s) applied at (position of earths) to be declared as **Primary Earth(s)**

The **Senior Authorised Person** shall ensure the **Drain Earth(s)** are positioned correctly, sufficiently rated to be quoted as a **Primary Earth** and not impinged by the position of adjacent **Equipment** e.g. earth resting against an arcing horn

Logged Confirmation (CP(S)1)

Written confirmation that at (**Location** and voltage) on (circuit) Earth(s) applied at (position of earths) are declared as **Primary Earth(s)**

Guidance

Safety Document
Procedures
P9.1 Cont.

Example

At Kitwell 132 kV Substation
On SGT1 circuit

Confirmation that Earth(s) applied adjacent to Earth Switch 181 have been declared as **Primary Earth(s)**.

Control Person (Safety) – shall dress the safety precaution on the IEMS. Following the declaration the control of the **Primary Earth(s)** are now the responsibility of the **Control Person (Safety)**

P9.3 With the exception of a **Sanction for Work** and **Certificate for Live LV Work** when the **Senior Authorised Person** is not available, the cleared **Safety Document** and any associated items should be placed inside a **Card Safe**. This safe being locked by a **Senior Authorised Person** control lock.

When a **Sanction for Work** or **Certificate for Live LV Work** is to be cleared it shall be handed direct to a **Senior Authorised Person** who shall then immediately cancel it.

Safety Rule

Safety Document
Procedures
P10

P10 Cancellation of Safety Documents

P10.1 A **Senior Authorised Person** shall cancel the **Safety Document**. He shall ensure that the **Control Person (Safety)** has been informed of the cancellation and any exceptions or restrictions affecting return to **Operational Service**.

Guidance

Safety Document
Procedures
P10.1

P10 Cancellation of Safety Documents

P10.1 The **Senior Authorised Person** shall:-

- (a) Before cancellation of any **Safety Document** the **Senior Authorised Person** shall note any exceptions and confirm whether or not the **Equipment** is in a condition to be returned to **Operational Service**. The **Senior Authorised Person** shall visually inspect the status of **Equipment** where appropriate, e.g. oil levels, gas pressures are normal and circuit clear of all earths etc.
- (b) Contact the **Control Person (Safety)** and advise him that a **Safety Document** is to be cancelled. The **Safety Document** description and number should be confirmed in order that the correct **Safety Document** is cancelled. The **Control Person (Safety)** shall be informed of any reasons why the **Equipment** should not be returned to **Operational Service** or any restrictions in the return to service.
- (c) Remove the **Safety Document** T Cards from the Substation Status Board and destroy the Tee Card.
- (d) Cross out reference to **Safety Document** on POI/Earthing/RISSP T Cards.

Guidance

Safety Document
Procedures
P10.1 Cont.

Where there is a restriction on return to **Operational Service** a Technical Limitation (TL) shall be issued.

When a **Safety Document** is cancelled with exceptions then the exceptions to returning equipment can either:-

Be recorded on a TL with the details also on a T Card and placed in the slot for TL's

Allow the immediate preparation and issue of another **Safety Document**, this shall be done if **Drain Earths** are still applied to **Equipment**.

Inform **Control Person** of change of state e.g. earth switch S11A and S11B open.

The completion of the Cancellation Section of a **Safety Document** by the **Senior Authorised Person** is the record that all items issued with the **Safety Document** have been returned.

The **Control Person (Safety)** shall confirm that they have the correct **Safety Document** to be cancelled by reading back to the **Senior Authorised Person**:

- The **Safety Document** identification to be cancelled
- **Equipment** Identification
- The work to be done sections of the document

The **Control Person (Safety)** shall log exceptions stated in the relevant section of the **Safety Document** and any restrictions to the return to service of the **Equipment**, unless work is to continue immediately under another **Safety Document**.

Particular attention shall be given to record and control the following:-

- Application / removal of **Earthing Devices** or disconnecting / re-connecting conductors under the **Safety Document** being cancelled
- **Drain Earths**, left applied to the **HV System**
- **Drain Earths** to be quoted as **Primary Earths**
- The possible effects of any extra work done under Section P7 of the **Safety Rules**
- Changes to the **System** for information when cancelling a **System State Certificate** with the **Control Person (Operation)**

Safety Rule

Safety Document
Procedures
P11

P11 Return to Operational Service

P11.1 Following the cancellation of all relevant **Safety Documents** and removal of safety precautions, the **Control Person (Safety)** shall transfer control of the **Equipment** back to the **Control Person (Operation)**.

P11.2 The **Control Person (Operation)** shall return the **Equipment** to **Operational Service**.

Guidance
Safety Document
Procedures
P11

P11 Return to Operational Service

- P11.1 The **Control Person (Safety)** shall inform the **Control Person (Operation)** of any restrictions to **Equipment** being returned to service.
- P11.2 The **System State Certificate** shall be cancelled.

Safety Rule
Safety Document
Procedures
P12

P12 Categories of Authorisation

- P12.1 The following categories of Authorisation are recognised in the Safety Rules. An individual may be appointed by an appropriate Manager for any number of these categories within specified limits.
- a **Person**
 - b **Competent Person**
 - c **Authorised Person**
 - d **Senior Authorised Person**
 - e **Control Person (Operation)**
 - f **Control Person (Safety)**

- P12.2 Records of Authorisation shall define responsibilities with respect to specific National Safety Instructions and Operational Authorities.

Guidance
Safety Document
Procedures
P12

P12 Categories of Authorisation

- P12.1 The procedures for the Appointment of various categories of authorisation are contained in Management Procedure NSI 30 – “Appointment of Persons”.

Safety Rule
Safety Document
Procedures
P13

P13 Safe Custody of Safety Documents and Associated Items

- P13.1 A **Card Safe** secured by a **Senior Authorised Person** shall be provided for safe custody of **Safety Document(s)**, supporting documents, **Key(s)** and shall be used for the following:-
- (a) **Safety Document(s)** which have been prepared but not issued
 - (b) **Safety Document(s)** which have been cleared but not cancelled
 - (c) **Safety Document(s)** which are in transfer
- P13.2 When a **Sanction for Work** or **Certificate for Live LV Work** is to be transferred by a **Senior Authorised Person** both the new recipient and person surrendering document shall be present at time of transfer. There shall be no undue delay in the transfer process.
- P13.3 All **Safety Document(s)** which have been issued including associated items shall be retained in safe custody by the recipient.

Guidance

Safety Document
Procedures
P13

P13 Safe Custody of Safety Documents and Associated Items

P13.3 To ensure **Drain Earths**, when not in use, are kept in safe custody, the **Safety Document** recipient shall keep them in a locked vehicle, box, cupboard or room etc. which can only be unlocked by himself, or:-

- (a) For substation earths a strap for tying and locking them together or attaching to a fixing e.g. earth strap.
- (b) For overhead line earths, set numbers in lockable canvas bag or secure container.

Personnel in receipt of **Safety Documents** shall retain all **Safety Documents** and associated items in safe custody by personal retention in plastic document wallets, safe custody box or by securing by other appropriate means.

The means of retaining documents and **Keys** in safe custody whilst issued includes locking within a document wallet such that no one but the **Competent Person** in charge of the work can gain access to the document or **Keys**. This includes the **Senior Authorised Person** who issued the document.

It is also important that:-

- The document(s) are available so that they can be referred to as and when required
- The **Safety Document** and **Keys** are in safe custody both during the working day, overnight and at weekends,

Safety Rule

Safety Document
Procedures
P14

P14 Multiple Safety Documents

P14.1 A series of **Safety Document(s)** bearing the same unique number although individually identified by a further unique alpha character.

P14.2 The **Senior Authorised Person** in consultation with the **HV Control Person (Safety)** will agree the wording to be used on the **Safety Document** in both Section 1 and 2. The **Senior Authorised Person** shall confirm that it is an initial document of multiple **Safety Document(s)**.

Guidance

Safety Document
Procedures
P14.1

P14 Multiple Safety Documents

P14.1 The **HV Control Person (Safety)** consents to the preparation of the initial **Safety Document** and provides the **Safety Document** number derived from the IEMS Management System with the suffix MPA (multiple permit A). E.g. W, MPA, MPB, C etc. **The first Safety Document issued shall be MPA and the last Safety Document cleared shall be MPA.**

Multiple permits for work can be issued for refurbishment work, routine maintenance and construction work. **For Overhead Lines work** additional guidance is available in Management Procedure NSI 4 - "Work on or Near High Voltage Overhead Lines"

Guidance

Safety Document Procedures

P14.2

P14.2 When associated documents are required all recipients of the **Safety Documents** shall be made aware of these. This includes **Working Party** registers, **Earthing Schedules**, risk assessments and method statements.

When multiple **Safety Documents** are produced the wording in Section 1 and 2 shall be identical on all multiple **Safety Documents**.

When multiple **Safety Document(s)** require a reference to **Drain Earths** established by the Master **Safety Document** (MPA) then the following shall apply:

The Master **Permit for Work** Section 2 'Further Precautions' shall be endorsed with:;

"Drain Earth(s) shall be applied as directed by the holder of this Master Permit for Work and in accordance with attached Earthing Schedule."

All Secondary multiple **Permit for Work(s)** Section 2 'Further Precautions' shall be endorsed with:

"Drain earth(s) shall be applied as directed by the Master Safety Document holder and in accordance with Safety Document No.----- (master safety document number)"

All Secondary **Safety Document(s)** associated with the Master **Permit for Work** will have zero **Drain Earth(s)** issued along with a copy of the Master **Earthing Schedule**.

The following statement must be included on the **Earthing Schedule** *"A daily check should be made before work starts that appropriate Drain Earth(s) are still in place."*

Note: Control of **Drain earth(s)** is co-ordinated by the holder of the master 'A' document. Due to electronic restrictions applied to documentation, there is no requirement for the **Control Person (Safety)** who consents to the **Safety Document** to add the section 2 detail as described above. In this case, the **Control Person (Safety)** copy of the **Safety Document** shall be endorsed with "Nil" or "N/A".

Forms of Documents

The Safety rules comprise of two categories of documentation

- **Safety Documents** – These are for controlling high risk activities associated with the Transmission System.

Limited Access Certificate (LAC)
Permit For Work (PFW)
OHL Permit For Work (PFW)
Sanction For Work (SFW)
Certificate For Live LV Work (CLLVW)

- **Supporting Documents** – These are additional documents that may be issued with Safety documents to control certain activities.

Status of Transfer Form
Safety Document Continuation Sheet
Working Party Register
Earthing Schedule

Safety Documents

nationalgrid LIMITED ACCESS CERTIFICATE

No.	
-----	--

1. LOCATION

EQUIPMENT IDENTIFICATION

WORK TO BE DONE

2.1 LIMITS OF WORK *

2.2 LIMITS OF WORK AREA*

2.3 Further precautions to be taken during the course of the work to avoid System derived hazards*

3. PREPARATION This Limited Access Certificate shall be personally retained

Senior Authorised Person	Print Name	Signed	Time	Date
			:	/ /

4. ISSUE & RECEIPT Under normal circumstances this Limited Access Certificate should be cancelled within 3 months of its issue

Earthing Schedule or Procedure No*		Drain Earths (OHL use only) or Temporary Earth Bonds (NSI 24 use only) (number issued)*		
Sketch Provided On this LAC	Yes / No#	If separate sketch is to be issued provide reference No.*		Card Safe (OHL use only) Number*
Senior Authorised Person	Print Name	Signed	Senior Authorised Person Mobile No*	
Competent Person	Print Name	Signed	Time	Date
Company Name			:	/ /
			Competent Person Mobile No*	

Delete as appropriate * Write N/A if not applicable November 2007

nationalgrid LIMITED ACCESS CERTIFICATE

5. SKETCH

6. TRANSFER RECORD

PART 1 - SURRENDER BY		PART 2 - RE-ISSUE			
Competent Person	TIME DATE	Senior Authorised Person	TIME DATE	Competent Person	TIME DATE
Print Name Signed Mobile No*		Print Name Signed Mobile No*		Print Name Signed Mobile No*	
Print Name Signed Mobile No*		Print Name Signed Mobile No*		Print Name Signed Mobile No*	
Print Name Signed Mobile No*		Print Name Signed Mobile No*		Print Name Signed Mobile No*	
Print Name Signed Mobile No*		Print Name Signed Mobile No*		Print Name Signed Mobile No*	
Print Name Signed Mobile No*		Print Name Signed Mobile No*		Print Name Signed Mobile No*	
Print Name Signed Mobile No*		Print Name Signed Mobile No*		Print Name Signed Mobile No*	

7. CLEARANCE This **Limited Access Certificate** is cleared

Competent Person	Print Name	Signed	Time :	Date / /
Company Name				

8. CANCELLATION

Senior Authorised Person	Print Name	Signed	Time :	Date / /
---------------------------------	------------	--------	--------	----------

*Write N/A if not applicable

NOVEMBER 2007*

nationalgrid PERMIT FOR WORK

No.	
-----	--

1. LOCATION

EQUIPMENT IDENTIFICATION

WORK TO BE DONE

2. PRECAUTIONS TAKEN TO ACHIEVE SAFETY FROM THE SYSTEM

Point(s) of Isolation

Primary Earths*

Actions taken to avoid **Danger** by draining, venting, purging and containment or dissipation of stored energy*

Further precautions to be taken during the course of the work to avoid **System** derived hazards*

3. PRECAUTIONS THAT MAY BE VARIED*

4. PREPARATION This Permit for Work shall be personally retained

Control Person(s) (Safety) giving Consent			Key Safe Number*	
Senior Authorised Person	Print Name	Signed	Time	Date
			:	/ /

5. ISSUE & RECEIPT

Approved ROMP Procedure Number(s)*			Key Safe Key Number*	
Safety Keys (Number issued)*		Earthing Schedule Number*	Portable Drain Earths (Number issued)*	
Senior Authorised Person	Print Name	Signed	Senior Authorised Person Mobile No*	
Competent Person	Print Name	Signed	Time	Date
			:	/ /
Company Name			Competent Person Mobile No*	

* Write N/A if not applicable

6. ADDITIONAL WORK SUBSEQUENT TO ISSUE
Equipment Identification and Work

.....

.....

.....

Additional Earthing Schedule Number*		Drain Earths (No off)*	Additional No. issued	Total now issued
Senior Authorised Person	Print Name	Signed		
Competent Person	Print Name	Signed	Time :	Date / /

7. TRANSFER RECORD

PART 1 - SURRENDER BY		PART 2 - RE-ISSUE			
Competent Person	TIME DATE	Senior Authorised Person	TIME DATE	Competent Person	TIME DATE
Print Name		Print Name		Print Name	
Signed		Signed		Signed	
Mobile No*		Mobile No*		Mobile No*	
Print Name		Print Name		Print Name	
Signed		Signed		Signed	
Mobile No*		Mobile No*		Mobile No*	
Print Name		Print Name		Print Name	
Signed		Signed		Signed	
Mobile No*		Mobile No*		Mobile No*	
Print Name		Print Name		Print Name	
Signed		Signed		Signed	
Mobile No*		Mobile No*		Mobile No*	
Print Name		Print Name		Print Name	
Signed		Signed		Signed	
Mobile No*		Mobile No*		Mobile No*	

8. CLEARANCE This **Permit for Work** is cleared, the following exceptions are recorded
 Confirm the operational state of **Equipment** quoted in Section 1 and any **Drain Earths** that remain applied as quoted on an **Earthing Schedule***

.....

.....

.....

Competent Person	Print Name	Signed	Time :	Date / /
Company Name				

9. CANCELLATION

Control Person(s) (Safety)		Informed of cancellation and any restriction on return to Operational Service		
Senior Authorised Person	Print Name	Signed	Time :	Date / /

* Write N/A if not applicable

nationalgrid OHL PERMIT FOR WORK

No	
----	--

1. LOCATION

EQUIPMENT IDENTIFICATION

WORK TO BE DONE

2. PRECAUTIONS TAKEN TO ACHIEVE SAFETY FROM THE SYSTEM

Point(s) of Isolation

Primary Earths*

Further precautions to avoid **System** derived hazards*

3. PREPARATION This Permit for Work shall be personally retained.

Control Person(s) (Safety) giving Consent		Key Safe Location & Number*		
Senior Authorised Person	Print name	Signed	Time	Date / /

4. ISSUE & RECEIPT

Key Safe Key Number*		Card Safe* Procedure Number		
Circuit Identification Colour / Symbols*				
Earthing Schedule Number*	Portable Drain Earths* (number issued)	Flags (number issued)*	Wristlets (number issued)*	
Senior Authorised Person	Print Name	Signed	Senior Authorised Person Mobile No*	
Competent Person	Print Name	Signed	Time	Date / /
Company Name			Competent Person Mobile No*	

Delete as appropriate * Write N/A if not applicable

nationalgrid OHL PERMIT FOR WORK

5. ADDITIONAL WORK SUBSEQUENT TO ISSUE					
Equipment identification and Work					
.....					
.....					
.....					
.....					
.....					
Additional Earthing Schedule Number*			Wristlets*	Additional No. issued*	Total now issued
Drain Earths*	Additional No issued	Total now issued		Circuit ID Flags*	Total now issued
Senior Authorised Person	Print Name	Signed			
Competent Person	Print Name	Signed		Time : / /	Date / /
6. TRANSFER RECORD					
PART 1 SURRENDER BY			PART 2 RE-ISSUE		
Competent Person	TIME DATE	Senior Authorised Person	TIME DATE	Competent Person	TIME DATE
Print Name		Print Name		Print Name	
Signed		Signed		Signed	
Mobile No*		Mobile No*		Mobile No*	
Print Name		Print Name		Print Name	
Signed		Signed		Signed	
Mobile No*		Mobile No*		Mobile No*	
Print Name		Print Name		Print Name	
Signed		Signed		Signed	
Mobile No*		Mobile No*		Mobile No*	
Print Name		Print Name		Print Name	
Signed		Signed		Signed	
Mobile No*		Mobile No*		Mobile No*	
Print Name		Print Name		Print Name	
Signed		Signed		Signed	
Mobile No*		Mobile No*		Mobile No*	
Print Name		Print Name		Print Name	
Signed		Signed		Signed	
Mobile No*		Mobile No*		Mobile No*	
7. CLEARANCE This Permit for Work is cleared, the following exceptions are recorded*					
Confirm the operational state of Equipment quoted in Section 1 and any Drain Earths that remain applied as quoted on an Earthing Schedule*					
.....					
.....					
.....					
.....					
Competent Person	Print name	Signed	Time : / /	Date / /	
Company Name					
8. CANCELLATION					
Control Person(s) (Safety)			Informed of cancellation and any restriction on return to Operational Service		
Senior Authorised Person	Print name	Signed	Time : / /	Date / /	

* Write N/A if not applicable

nationalgrid SANCTION FOR WORK

No	
----	--

1. LOCATION.....

EQUIPMENT IDENTIFICATION.....

WORK TO BE DONE.....

2. PRECAUTIONS TAKEN TO ACHIEVE **SAFETY FROM THE SYSTEM**

Point(s) of Isolation.....

Primary Earths.....

Actions taken to avoid **Danger** by draining, venting, purging and containment or dissipation of stored energy*.....

Further precautions to be taken during the course of the work to avoid **System** derived hazards*.....

3. PRECAUTIONS THAT MAY BE VARIED*.....

4. PREPERATION This Sanction for Work shall be personally retained

Control Person(s) (Safety) giving Consent			Key Safe Number*	
Senior Authorised Person	Print name	Signed	Time	Date / /
			:	/ /

5. ISSUE & RECEIPT

Approved ROMP#/SFW# Procedure Number(s)*			Key Safe Key Number*	
Safety Keys (number issued)*		Earthing Schedule Number*	Portable Drain Earths (number issued)*	
Circuit Identification Colours Symbols*			Flags (number issued)*	Wristlets (number issued)*
Senior Authorised Person	Print name	Signed	Senior Authorised Person Mobile No*	
Competent Person	Print name	Signed	Time	Date / /
			:	/ /
Company Name			Competent Person Mobile No*	

Delete as appropriate * Write N/A if not applicable

nationalgrid SANCTION FOR WORK

6. ADDITIONAL WORK SUBSEQUENT TO ISSUE				
Equipment identification and Work.....				
Additional Earthing Schedule Number*		Drain Earths (No off)*	Additional No. issued	Total now issued
Senior Authorised Person	Print Name	Signed		
Competent Person	Print Name	Signed	Time :	Date / /
7. TRANSFER RECORD				
PART 1 SURRENDER BY		PART 2 RE-ISSUE		
Competent Person		Senior Authorised Person	Competent Person	TIME DATE
Print Name		Print Name	Print Name	
Signed		Signed	Signed	
Mobile No*		Mobile No*	Mobile No*	
Print Name		Print Name	Print Name	
Signed		Signed	Signed	
Mobile No*		Mobile No*	Mobile No*	
Print Name		Print Name	Print Name	
Signed		Signed	Signed	
Mobile No*		Mobile No*	Mobile No*	
Print Name		Print Name	Print Name	
Signed		Signed	Signed	
Mobile No*		Mobile No*	Mobile No*	
Print Name		Print Name	Print Name	
Signed		Signed	Signed	
Mobile No*		Mobile No*	Mobile No*	
8. CLEARANCE This Sanction for Work is cleared, the following exceptions are recorded				
Confirm the operational state of Equipment quoted in Section 1 & 3, also any Drain Earths that remain applied as quoted on a Earthing Schedule*				
.....				
Competent Person	Print name	Signed	Time :	Date / /
Company Name				
9. CANCELLATION				
Control Person(s) (Safety)		Informed of cancellation and any restriction on return to Operational Service		
Senior Authorised Person	Print name	Signed	Time :	Date / /

* Write N/A if not applicable

nationalgrid CERTIFICATE FOR LIVE LV WORK

No

1. LOCATION

EQUIPMENT IDENTIFICATION

WORK TO BE DONE

2. JUSTIFICATION FOR WORKING LIVE

3. HAZARDS The following have been identified and assessed

4. PRECAUTIONS TO BE TAKEN TO ESTABLISH A SAFE SYSTEM OF WORK

Point(s) of Isolation*

List controls established as part of the safe system of work (e.g. Insulated Screening, Insulated Tools, PPE etc.).....

Specific instructions to be followed in the Event of an Emergency

5. PREPERATION This **Certificate For Live LV Work** shall be personally retained

Control Person(s) (Safety) giving Consent			Key Safe Number*	
Senior Authorised Person	Print name	Signed	Time :	Date / /

6. ISSUE & RECEIPT

Procedure Number(s)*				
Safety Keys (number issued)*		Sketch Provided # YES / NO		Key Safe Key Number*
Senior Authorised Person	Print name	Signed		Senior Authorised Person Mobile No*
Competent Person	Print name	Signed		Time : Date / /
Company Name				Competent Person Mobile No*

Delete as appropriate * Write N/A if not applicable

nationalgrid CERTIFICATE FOR LIVE LV WORK

7. SKETCH*

8. TRANSFER RECORD

PART 1 SURRENDER BY	PART 2 RE-ISSUE		
Competent Person	Senior Authorised Person	Competent Person	TIME DATE
Print Name Signed Mobile No*	Print Name Signed Mobile No*	Print Name Signed Mobile No*	
Print Name Signed Mobile No*	Print Name Signed Mobile No*	Print Name Signed Mobile No*	
Print Name Signed Mobile No*	Print Name Signed Mobile No*	Print Name Signed Mobile No*	
Print Name Signed Mobile No*	Print Name Signed Mobile No*	Print Name Signed Mobile No*	
Print Name Signed Mobile No*	Print Name Signed Mobile No*	Print Name Signed Mobile No*	

9. CLEARANCE This Certificate For Live LV Work is cleared with the following recorded exceptions or limitations*

.....

.....

.....

.....

.....

.....

Competent Person	Print name	Signed	Time :	Date / /
-------------------------	------------	--------	--------	--------------

Company Name

10. CANCELLATION Informed of cancellation and any restriction on return to **Operational Service**

Senior Authorised Person	Print name	Signed	Time :	Date / /
---------------------------------	------------	--------	--------	--------------

* Write N/A if not applicable

Supporting Documents



**National Grid Electricity Transmission
 Electricity Safety Rules**

STATUS OF TRANSFER / SUSPENSION FORM

SAFETY DOCUMENT NUMBER		
Location		
1. ITEMS TO BE TRANSFERRED / SUSPENDED		
Earthing Schedule	Approved ROMP Procedure	Safety Key(s)
Flags	Wristlets	Key Safe Key(s)
Other Items Issued	Handed over or location if items	
Fuses / Links	As identified in section 3 "precautions that may be varied" of safety document*	
Drain Earths		
Any other items		
2. SAFETY ASPECTS REQUIRING SPECIAL ATTENTION		
No ROMP activities to be undertaken* / Drain Earths(s) not to be interfered with.*		
3. STATUS OF WORK AND OTHER RELEVANT INFORMATION		
ROMP supplies isolated and secured in Key Safe number..* / Earthing Schedule secured in..*		
Signature of Competent Person surrendering the Safety Documents (N/A for suspension)		
Print Name _____	Signed _____	Time _____ Date _____
Signature of Senior Authorised Person responsible for Safety Custody / Suspension		
Print Name _____	Signed _____	Time _____ Date _____
4. INSTRUCTION / INFORMATION REQUIRED TO BE COMMUNICATED AT THE REISSUE OF THE SAFETY DOCUMENT		
Signature of Senior Authorised Person re-issuing the Safety Documents		
Print Name _____	Signed _____	Time _____ Date _____
Signature of new Competent Person receiving the transferred Safety Documents		
Print Name _____	Signed _____	Time _____ Date _____

* Delete as appropriate

April 2013



SAFETY DOCUMENT CONTINUATION

SHEET / TRANSFER RECORD NO. _____

PART1 SURRENDER BY		ADDITIONAL TRANSFER RECORD			
		PART2 RE-ISSUE			
COMPETENT PERSON	TIME DATE	SENIOR AUTHORISED PERSON	TIME DATE	COMPETENT PERSON	TIME DATE
Print Name	>	Print Name	>	Print Name	
Signed		Signed		Signed	
Mobile No*		Mobile No*		Mobile No*	
Print Name	>	Print Name	>	Print Name	
Signed		Signed		Signed	
Mobile No*		Mobile No*		Mobile No*	
Print Name	>	Print Name	>	Print Name	
Signed		Signed		Signed	
Mobile No*		Mobile No*		Mobile No*	
Print Name	>	Print Name	>	Print Name	
Signed		Signed		Signed	
Mobile No*		Mobile No*		Mobile No*	
Print Name	>	Print Name	>	Print Name	
Signed		Signed		Signed	
Mobile No*		Mobile No*		Mobile No*	
Print Name	>	Print Name	>	Print Name	
Signed		Signed		Signed	
Mobile No*		Mobile No*		Mobile No*	
Print Name	>	Print Name	>	Print Name	
Signed		Signed		Signed	
Mobile No*		Mobile No*		Mobile No*	
Print Name	>	Print Name	>	Print Name	
Signed		Signed		Signed	
Mobile No*		Mobile No*		Mobile No*	
Print Name	>	Print Name	>	Print Name	
Signed		Signed		Signed	
Mobile No*		Mobile No*		Mobile No*	
Print Name	>	Print Name	>	Print Name	
Signed		Signed		Signed	
Mobile No*		Mobile No*		Mobile No*	
Print Name	>	Print Name	>	Print Name	
Signed		Signed		Signed	
Mobile No*		Mobile No*		Mobile No*	
Print Name	>	Print Name	>	Print Name	
Signed		Signed		Signed	
Mobile No*		Mobile No*		Mobile No*	
Print Name	>	Print Name	>	Print Name	
Signed		Signed		Signed	
Mobile No*		Mobile No*		Mobile No*	
Print Name	>	Print Name	>	Print Name	
Signed		Signed		Signed	
Mobile No*		Mobile No*		Mobile No*	

*Write N/A if not applicable > Not for use on SFW or CFLW

April 2013



**National Grid Electricity Transmission
 Electricity Safety Rules**

WORKING PARTY REGISTER

The register shall be completed by the **Senior Authorised Person** issuing a **Safety Document** and the **Competent Person** who is the recipient of the **Safety Document** (if Safety rules apply) or in all other cases, the **Person** in charge of the work.

The persons completing Section 2 of the register shall ensure all members of the **Working Party** understand the contents of the **Safety Document** (if applicable) and any documents listed on this register before they sign it.

1. Completed by Senior Authorised Person		
Safety Document type, number and work detail		
DOCUMENTS	DOCUMENT REF	DOCUMENT REF
JOB/SITE SPECIFIC RISK ASSESSMENT(S)		
METHOD STATEMENT(S)		
WORK SPECIFICATION(S)		
ANY OTHER RELEVANT DOCUMENT(S)		
ADDITIONAL WORK YES/NO* (SPECIFY ADDITIONAL WORK & ADDITIONAL ASSOCIATED DOCUMENTATION)		
STATUS OF TRANSFER FORM ISSUED? YES/NO*		

2. Completed by Competent Person or Person in charge of the Work

The following Toolbox Talks have been completed by: (Use Toolbox Talk Check List if required)

Name	Name	Name	Name
Date	Date	Date	Date
Time	Time	Time	Time
Name	Name	Name	Name
Date	Date	Date	Date
Date	Date	Date	Date
Time	Time	Time	Time
Date	Date	Date	Date
Time	Time	Time	Time

April 2013



WORKING PARTY REGISTER

I HAVE BEEN INSTRUCTED AND UNDERSTAND THE CONTENTS OF THE DOCUMENTS IDENTIFIED OVERLEAF AND AGREE TO BEING ADDED TO THE WORKING PARTY.

NAMES AND SIGNATURE OF INDIVIDUALS IN OR ADDED TO THE WORKING PARTY.			ADDED TO		REMOVED FROM	
Name (Print)	Signature	Mobile No:	Time	Date	Time	Date

ANY ADDITIONAL DOCUMENTS, ISSUED SUBSEQUENT TO WORK COMMENCING, MUST BE COMMUNICATED TO THE WORKING PARTY BY THE RECIPIENT.
 NOTE: All personnel who join the Working Party at a later date must be given a Tool Box Talk and the same information given to them as to those who joined the Working Party at the beginning of the work.

April 2013

National Grid Electricity Transmission
Electricity Safety Rules



EARTHING SCHEDULE

Number	
--------	--

Location		Associated Safety Document Number	
-----------------	--	------------------------------------------	--

Equipment/Circuit	
--------------------------	--

POSITION OF DRAIN EARTHS AT EACH STAGE OF WORK

- NOTES:
- Work must not commence on any stage until the earthing requirements for that stage have been completed.
 - Scheme, Stage or Job No. marked* shall be carried out under the **Personal Supervision** of a **Competent Person** or a **Senior Authorised Person** as detailed in the 'Remarks' Section.

Scheme, Stage or Job No.	Work Description	DRAIN EARTHS	
		Location	Number

SKETCH/REMARKS/OHL CONTRACTORS EARTHING SCHEDULE

Number of Portable Earths Issued:

Normal	<input type="text"/>
Temporary Earth Bonds NSI 24	<input type="text"/>
Short Drain	<input type="text"/>
Bridging	<input type="text"/>
Running	<input type="text"/>
Earthing Bridles	<input type="text"/>
Others	<input type="text"/>
Total issued	<input type="text"/>
Fixed Earthing Devices	<input type="text"/>

(Use should be specified in Work Description)

ISSUE (Signed)

Senior Authorised Person

TIME: :

DATE: / /

CANCELLATION (Signed)

Senior Authorised Person

TIME: :

DATE: / /

Guidance Notes for Documents

- **Safety Documents** – These are for controlling high risk activities associated with the Electricity Transmission System.

Limited Access Certificate (LAC) – Substations and OHL

Permit For Work (PFW)

OHL Permit for Work (PFW)

Sanction for Work (SFW)

Certificate for Live LV Work (CLLVW)

Earthing Schedule Guidance (OHL)

Earthing Schedule Guidance for Complex work (OHL)

Safety Document Guidance

**Guidance for the Preparation of
Substations
Limited Access Certificates (Front)**

Identify the **Location(s)** of the **Equipment**
For work in a Substation – name of Substation and the voltage

The description shall make clear the extent of the work which is permitted.
A **Working Party** Register shall be issued along with any **Safety Document**; this negates the need to reference any method statement in Section 1 of the **Safety Document** as the **Working Party** Register incorporates this information.

Specify the physical limits of the work that will ensure **Safety from the System.**

Specify all physical limits of the work area that ensure **Safety from the System.**

The **Senior Authorised Person** preparing the **Limited Access Certificate** shall print, sign, time and date this section. This confirms that the precautions stated in Sections 2.1 and 2.2 have been carried out and that procedures have been put in place to maintain these until the **Limited Access Certificate** is cancelled.

The **Senior Authorised Person** issuing the **Limited Access Certificate** shall Record if applicable the **Earthing Schedule** number, the number of OHL **Drain Earths** or Temporary Earth Bonds for NSI 24 work, and items to be issued to the recipient. The **Senior Authorised Person** then signs this section of the **Limited Access Certificate.**

The **Limited Access Certificate** shall be received by a **Competent Person** authorised to carry out the work in Section 1.

The recipient will print, sign, time and date this Section of the **Limited Access Certificate** confirming receipt of the listed items and procedures and confirming their acceptance and understanding of the contents and requirements of the **Limited Access Certificate.**

No

A unique pre-printed number is provided. This number is used when the **Safety Document** is issued.

1. LOCATION.....
.....
.....
EQUIPMENT / IDENTIFICATION
.....
.....
.....
WORK TO BE DONE
.....
.....
.....

Identify **Equipment** to be worked on or near to as appropriate.

When the work is to be undertaken near to a specific item of **Equipment** the identification quoted should be the same as that on the **Equipment** itself e.g. for repairs to a transformer bund wall the transformer identification should be inserted see P4.1 guidance for details.

When the work to be undertaken is near to multiple items of **Equipment** Not Applicable should be inserted e.g. for weed killing being undertaken in a **HV** Compound Not Applicable should be inserted in **Equipment** Identification.

For work on a cable circuit, where appropriate refer to joint bay/link pit numbers, sealing ends or terminal towers.

2.1 LIMITS OF WORK*

2.2 LIMITS OF WORK AREA*

2.3 Further precautions to be taken during the course of the work to avoid **System** derived hazards*

General Considerations

All **Safety Documents** shall be completed clearly and legibly, Block Capitals are recommended.
The **Senior Authorised Person** shall ensure abbreviations are understood by the **Competent Person** receiving the **Safety Document.**

The **Senior Authorised Person** completing **Safety Document** shall ensure the precise requirements of each section are met indicating that all sections have been given consideration by entering the full details required or N/A.

Alterations on **Safety Documents** should wherever possible be avoided; they are not acceptable in Section 1. Alterations to other sections shall be completed by the obliteration of the complete word or item to be changed; all changes should be initialled by the **Senior Authorised Person.**

When the preparation section is completed and signed alterations to the contents are not permitted.

Include all precautions to avoid **System** derived hazards which are to be taken during the work.

- If the DAR on the adjacent circuit is to be switched out during the work this should be specified.
- Include **Earthing Schedule** or NSI 24 Temporary Earth Bonds.

3. PREPARATION This **Limited Access Certificate** shall be personally retained

Senior Authorised Person	Print Name	Signed	Time	:	Date / /
---------------------------------	------------	--------	------	---	----------

4. ISSUE & RECEIPT Under normal circumstances this **Limited Access Certificate** should be cancelled within 3 months of its issue

Earthing Schedule or Procedure No*		Drain Earths (OHL use only) or Temporary Earth Bonds (NSI 24 use only) (number issued)*			
Sketch Provided On this LAC	Yes / No #	If separate sketch is to be issued provide reference No*		Card Safe (OHL use only) Number*	
Senior Authorised Person	Print Name	Signed	Senior Authorised Person Mobile No*		
Competent Person	Print Name	Signed	Time	:	Date / /
Company Name			Competent Person Mobile No*		

#Delete as appropriate *Write N/A if not applicable

Guidance for the Preparation of OHL & Substations Limited Access Certificates (Back)

If necessary this section is to be used by the **Senior Authorised Person** to clarify the limits of the work area with a simple sketch.

5. SKETCH

6. TRANSFER RECORD

PART 1 - SURRENDER BY		PART 2 - RE-ISSUE			
Competent Person	TIME DATE	Senior Authorised Person	TIME DATE	Competent Person	TIME DATE
Print Name		Print Name		Print Name	
Signed		Signed		Signed	
Mobile No*		Mobile No*		Mobile No*	
Print Name		Print Name		Print Name	
Signed		Signed		Signed	
Mobile No*		Mobile No*		Mobile No*	
Print Name		Print Name		Print Name	
Signed		Signed		Signed	
Mobile No*		Mobile No*		Mobile No*	
Print Name		Print Name		Print Name	
Signed		Signed		Signed	
Mobile No*		Mobile No*		Mobile No*	
Print Name		Print Name		Print Name	
Signed		Signed		Signed	
Mobile No*		Mobile No*		Mobile No*	

The **Competent Person** transferring the **Limited Access Certificate** shall sign, print, time and date Part 1 of the Transfer Record. Before signing the Transfer, the **Competent Person** shall ensure:

- The work area and all **Equipment** being worked on are left in a safe condition
- That a Status of Transfer form is completed detailing the stage of the work
- All individuals in his **Working Party** have been withdrawn from the work area and warned not to re-continue work on the **Equipment** concerned

If the **Limited Access Certificate** is not to be immediately re-issued the **Limited Access Certificate** and associated documentation, **Keys** and items listed in Section 4 shall be deposited in a secure place as specified in the Safety Rules Guidance Information.

Limited Access Certificate shall only be re-issued by a **Senior Authorised Person**. The transfer shall be to the same standard as the original issue.

7. CLEARANCE This **Limited Access Certificate** is cleared

Competent Person	Print Name	Signed	Time	:	Date	/	/
Company Name							

The **Competent Person** shall ensure that all individuals in the **Working Party** have been withdrawn from, and warned not to re-continue work on the **Equipment** concerned.

In addition all gear, tools, **Drain Earths** and loose materials shall have been removed and guards and access doors replaced.

The **Competent Person** clearing the **Limited Access Certificate** shall sign and print their names and enter the date time and date of the clearance.

The **Senior Authorised Person** shall sign and print their name then enter the time and date of the cancellation of the **Limited Access Certificate**.

8. CANCELLATION

Senior Authorised Person	Print Name	Signed	Time	:	Date	/	/
---------------------------------	------------	--------	------	---	------	---	---

*Write N/A if not applicable

Guidance for the Preparation of OHL Limited Access Certificates (Front)

Note 1. Refer to **System** information to verify the voltage of the route. Some routes have circuits with different voltages, where this is the case use the higher voltage only.

Note 2. Always ensure that the **Equipment** I/D is the same as that on the **Equipment** itself. Check route diagrams to ensure correct route names are used. For long OHL routes consider breaking the route down into manageable sections.

Note 3. Section 2.1 Limits of Work is not a repeat of Section 1 Work to be done, consider how the actual work itself needs to be limited.

Note 4. It is advisable not to refer to 'maintaining' a **Safety Distance** of 1.4, 2.4 or 3.1m from live conductors in the further precautions as this then implies that a judgement should be made by the person(s) working on the tower. By allowing safe access under a LAC and limiting the work and work area the **Senior Authorised Person** has already made that judgement.

Note 5. Consider making reference to windy conditions very carefully. The **Senior Authorised Person** must assess the impact of wind on conductor movement when planning the work and preparing the **Safety Document** this should also be documented in the risk assessment and method statements produced for the work. The **Senior Authorised Person** may consider requiring additional levels of supervision during some elements of the work.

Note 6 It is acceptable to list more than one route in Section 1 of an LAC provided that:

- The voltages of the routes is the same,
- The work to be done is common to all listed routes / **Equipment**,
- That all the **Equipment** is clearly identified.

During the LAC preparation process the **Senior Authorised Person** must ensure that **Safety from the System** and the safe system of work will not be compromised. The Maximum number of different routes that can be managed on any one LAC is 6

Note 7 Ensure that the LAC and work is reviewed within the recommended time frame of 3 months; consider any conditions that may have changed during this time period.

Cellular Installations.

Where Cellular installations are known, the best practice is to omit the relative towers from Section 1 of the main LAC and issue an additional safety document for the work on that specific tower on the day of the Cellular outage.

If this is not reasonably practicable then the requirement for Cellular precautions to maintain safety from the Cellular system can be documented in the Section 2.3 Further precautions – A statement can also be inserted to ensure that no work commences until a Record of Cellular Isolation document has been issued. This information should also be recorded in the RAMS and detailed in the Toolbox Talk and recorded on the Toolbox Talk report form.

nationalgrid LIMITED ACCESS CERTIFICATE

No

A unique pre-printed number is provided. This number is used when the **Safety Document** is issued.

1. **LOCATION**

EQUIPMENT / IDENTIFICATION

.....

WORK TO BE DONE

.....

Identify the **Location(s)** of the **Equipment**. For work in a Substation include the name and voltage of the Substation. For work on an OHL the route name and voltage (See Note 1)

Identify the **Equipment** to be worked on or near to. The identification of the **Equipment** should be the same as that on the **Equipment** itself. (See Note 2)

Specify clearly the work to be done. Ensure it adequately defines the work content. It is not a requirement to specify RAMS as these are listed in the **Working Party Register**

2.1 **LIMITS OF WORK***

.....

Where applicable specify clearly the exact physical limits of the work to ensure **Safety from the System**.

E.g. (1) 'Work limited to replacing Anti Climbing Guards' or e.g. (2) 'Work limited to the replacement of E/W fitting dowel pin. No disconnection of E/W jumper permitted' (See Note below)

Where this is not applicable insert N/A (See Note 3)

2.2 **LIMITS OF WORK AREA***

.....

Specify clearly the physical limits of the work area that ensure **Safety from the System**.

E.g. (1) 'Work area limited to the 3m above the ACD level' (to allow positioning of fall arrest equipment etc)

or

E.g. (2) Work limited to the tower body and tower peak. (Not just the tower peak as access up the body is required-this is Work)

(See Notes opposite). If limiting access to within 1m of the E/W specify here.

2.3 Further precautions to be taken during the course of the work to avoid **System** derived hazards*

.....

If **Drain Earths** are required to access within 1m of the earth wire or for work on the earth wire specify here. (Also see Notes opposite.)

Enter the correct number of **Drain Earths**

3. **PREPARATION** This **Limited Access Certificate** shall be personally retained

Senior Authorised Person	Print Name	Signed	Time	Date
			:	/ /

4. **ISSUE & RECEIPT** Under normal circumstances this **Limited Access Certificate** should be cancelled within 3 months of its issue

Earthing Schedule or Procedure No*		Drain Earths (OHL use only) or Temporary Earth Bonds (NSI 24 use only) (number issued)*		
Sketch Provided On this LAC	Yes / No #	If separate sketch is to be issued provide reference No*		Card Safe (OHL use only) Number*
Senior Authorised Person	Print Name	Signed	Senior Authorised Person Mobile No*	
Competent Person	Print Name	Signed	Time	Date
			:	/ /
Company Name			Competent Person Mobile No*	

General Notes

1. Ensure the text on the **Safety Document** is clear and legible.
2. Ensure that the carbon copies are clearly legible.
3. Use block capitals where possible.
4. No alterations are permitted in section 1.
5. Alterations in Section 2 should be initialised by the **Senior Authorised Person**. Items that have been changed should be totally obliterated.
6. No alterations are permitted after the preparation has been completed.

nationalgrid PERMIT FOR WORK

No

Identify the **Location(s)** of the **Equipment**.
Name the Substation and the voltage.
For work on a cable, not within a Site boundary, the name and voltage of the circuit.

Identify **Equipment** to be worked on or near to.

- The identification quoted should be the same as that on the **Equipment** itself. When safety precautions are established on **Equipment** to facilitate work on *Plant* or any structure(s) i.e. blockhouse roof, cladding on a building, lamp post or tree etc, which are not part of the **System** the **Equipment** to which the safety precautions have been established shall be identified see P4.1 guidance for details.
- For work on a cable circuit, where appropriate refer to joint bay/link pit numbers, sealing ends or terminal towers.
- For work on **LV Equipment**, record the circuit name, or if identified by symbols, describe the symbols and state the colour code.

All **Point(s) of Isolation** and their geographical location shall be included if remote from the **Location** of the work.

Where the integrity of a **Point of Isolation** is dependent on SF6 gas at the designated density, the statement "IGDD" (Isolation Gas Density Dependent) shall be recorded against the **Point of Isolation**, and the **Control Person(s) Safety** shall be informed of the name and contact detail of the **Competent Person** receiving the **Permit for Work** (see also document transfer guidance) **Point(s) of Isolation** that may be restored under Restoration of Motive Power shall also be included.

All relevant **Primary Earths** shall be identified with their geographical location if remote from the **Location** of the work.

For an **LV** or mechanical **Permit for Work** it is permissible to obliterate the "**Primary Earths**" subsection to provide additional space to continue the **Point(s) of Isolation** when required.

Include all precautions to avoid **System** derived hazards which are to be taken during the work.

- Specify any stored energy that is safely contained but shall be released either before the work commences or during the course of the work.
- The precautions to be taken to release this stored energy shall be specified.
- If the **DAR** on the adjacent circuit is to be switched out during the work this should be specified.
- Refer to any **Earthing Schedule** issued.

Names of **Control Person(s) (Safety)** giving **Consent**. This provides confirmation that the **Equipment** released for work has been correctly identified in Section 1.

For **HV Equipment**, It also confirms that the safety precautions stated in Section 2 for which the **Control Person(s) (Safety)** is responsible have been carried out and that with the exception of those precautions quoted in Section 3, procedures have been put in place to maintain these until the **Permit for Work** has been cancelled.

For **LV** work, Section 3 is not applicable.

The **Senior Authorised Person** preparing the **Permit for Work** shall print, sign, time and date the **Permit for Work**. This confirms that **Consent** has been given by the **Control Person(s) (Safety)** and that the precautions stated in Section 2 have been carried out and that the procedures have been put in place to maintain these until the **Permit for Work** is cancelled.

1. **LOCATION**.....
EQUIPMENT IDENTIFICATION
.....
.....
.....
WORK TO BE DONE
.....
.....
.....

2. **PRECAUTIONS TAKEN TO ACHIEVE SAFETY FROM THE SYSTEM**
Point(s) of Isolation
.....
.....
.....
Primary Earths*
.....
.....
Actions taken to avoid Danger by draining, venting, purging and containment or dissipation of stored energy*
.....
.....
Further precautions to be taken during the course of the work to avoid System derived hazards*
.....
.....

3. **PRECAUTIONS THAT MAY BE VARIED***

4. **PREPARATION** This **Permit for Work** shall be personally retained.

Control Person(s) (Safety) giving Consent		Key Safe Number*	
Senior Authorised Person	Print Name	Signed	Time : Date / /

5. **ISSUE & RECEIPT**

Approved ROMP Procedure Number(s)*		Key Safe Key Number*	
Safety Keys (number issued)*		Portable Drain Earths (number issued)*	
Senior Authorised Person	Print Name	Signed	Senior Authorised Person Mobile No*
Competent Person	Print Name	Signed	Time : Date / /
Company Name		Competent Person Mobile No*	

A unique pre-printed number is provided for identification of locally issued **LV** and mechanical **Safety Documents**.
The **Senior Authorised Person** inserts the unique identifying number given by the **HV Control Person (Safety)** in this case the pre-printed number shall be deleted.

The description shall make clear the extent of the work which is permitted in relation to the precautions described in Section 2. For more guidance see Safety Rule Guidance Section P4 – Preparation of **Safety Documents**.
A **Working Party** Register shall be issued along with any **Safety Document**; this negates the need to reference any method statement in Section 1 of the **Safety Document** as the **Working Party** Register incorporates this information.

General Considerations

All **Safety Documents** shall be completed clearly and legibly, Block Capitals are recommended.
The **Senior Authorised Person** shall ensure abbreviations are understood by the **Competent Person** receiving the **Safety Document**.
The **Senior Authorised Person** completing **Safety Documents** shall ensure the precise requirements of each section are met indicating that all sections have been given consideration by entering the full details required or N/A.
Alterations on **Safety Documents** should wherever possible be avoided; they are not acceptable in Section 1. Alterations to other sections shall be completed by the obliteration of the complete word or item to be changed; all changes should be initialled by the **Senior Authorised Person**.
When the preparation section is completed and signed alterations to the contents are not permitted.

Action taken to drain, vent or purge **Equipment** and contain or dissipate stored energy shall be included.

For **Approved ROMP** work details of the motive power that may be restored under the **Approved** procedure by the recipient of **Permit for Work** shall be recorded.

The **Senior Authorised Person** issuing the **Permit for Work** shall Record:

- The **Key Safe Key** Number
- Any **Approved ROMP** procedure numbers
- The items to be issued to the recipient

Then print their name and sign the **Permit for Work**.

The **Permit for Work** shall be received by a **Competent Person** authorised to carry out the work in Section 1 and/or vary the precautions in Section 3.

The recipient will print, sign, time and date this Section of the **Permit for Work** confirming their understanding of the **Safety Document** and its requirements and receipt of the items listed and Procedures detailed within this section of the **Permit for Work**.

*Write N/A if not applicable

nationalgrid PERMIT FOR WORK

If during the course of work, additional work is identified that is not specified in Section 1, a **Senior Authorised Person** shall be consulted. He shall assess the implications of the additional work with regards to the **Isolated System** and **Safety from the System**.

If the **Senior Authorised Person** decides that the additional work requires extra **Drain Earths** or the issue of a new **Earthing Schedule** this shall be included here.

Fixed Earthing Devices may be used on an additional Earthing Schedule.

The **Senior Authorised Person** authorises the additional work by printing and signing their name.

The **Competent Person** will print, sign, time and date the Acknowledgement section to confirm receipt of the listed items and their understanding of the contents and addition requirements of the **Permit for Work**.

The **Working Party** Register shall be updated if there are significant changes to the methods of work, these changes must be communicated via the tool box talk process.

6. ADDITIONAL WORK SUBSEQUENT TO ISSUE

Equipment Identification and Work

.....

.....

.....

Additional Earthing Schedule Number*	Drain Earths	Additional No. issued	Total now issued
Senior Authorised Person	Print Name	Signed	
Competent Person	Print Name	Signed	Time : Date / /

7. TRANSFER RECORD

PART 1 - SURRENDER BY		PART 2 - RE-ISSUE			
Competent Person	TIME DATE	Senior Authorised Person	TIME DATE	Competent Person	TIME DATE
Print Name		Print Name		Print Name	
Signed		Signed		Signed	
Mobile No*		Mobile No*		Mobile No*	
Print Name		Print Name		Print Name	
Signed		Signed		Signed	
Mobile No*		Mobile No*		Mobile No*	
Print Name		Print Name		Print Name	
Signed		Signed		Signed	
Mobile No*		Mobile No*		Mobile No*	
Print Name		Print Name		Print Name	
Signed		Signed		Signed	
Mobile No*		Mobile No*		Mobile No*	
Print Name		Print Name		Print Name	
Signed		Signed		Signed	
Mobile No*		Mobile No*		Mobile No*	
Print Name		Print Name		Print Name	
Signed		Signed		Signed	
Mobile No*		Mobile No*		Mobile No*	

8. CLEARANCE

This **Permit for Work** is cleared, the following exceptions are recorded

Confirm the operational state of **Equipment** quoted in Section 1 and any **Drain Earths** that remain applied as quoted on an **Earthing Schedule***

.....

.....

.....

Competent Person	Print Name	Signed	Time : Date / /
Company Name			

9. CANCELLATION

Control Person(s) (Safety)	Informed of cancellation and any restriction on return to Operational Service		
Senior Authorised Person	Print Name	Signed	Time : Date / /

The **Senior Authorised Person** shall sign and print their name then enter the time and date that the **Control Person(s) (Safety)** is informed of the cancellation of the **Permit for Work** with any exceptions and any outstanding restrictions on the return to **Operation Service**. The **Senior Authorised Person** shall also confirm the operational state of: **Equipment** quoted in Section 1 of the **Permit for Work** and fixed **Earthing Devices** or applied **Drain Earths** quoted on any **Earthing Schedule**.

The **Competent Person** transferring the **Permit for Work** shall sign, print, time and date Part 1 of the Transfer Record. Before signing the Transfer, the **Competent Person** shall ensure:

- The work area and all **Equipment** being worked on are left in a Safe condition.
- That a Status of Transfer form is completed detailing the stage of the work, and the status of the precautions that may be varied in Section 3 of the **Permit for Work**.
- All individuals in his **Working Party** have been withdrawn from the work area and warned not to re-continue work on the **Equipment** concerned.

If the **Permit for Work** is not to be immediately re-issued the **Permit for Work** and associated documentation, **Keys** and items listed in Section 5 shall be deposited in a secure place as specified in the Safety Rules Guidance information.

Where the integrity of a **Point of Isolation** is dependent on SF6 gas at the designated density, the **Control Person(s) (Safety)** shall be informed of the transfer and the name of the new **Competent Person** and his contact information.

Permit for Work shall only be re-issued by a **Senior Authorised Person**. The transfer shall be to the same standard as the original issue.

The **Competent Person** shall ensure that all individuals in the **Working Party** have been withdrawn from, and warned not to re-continue work on the **Equipment** concerned. In addition all gear, tools, **Drain Earths** and loose materials shall have been removed and guards and access doors replaced.

The **Competent Person** shall record any exceptions and any outstanding restrictions on the return to **Operation Service**. The **Competent Person** shall also confirm the operational state of: **Equipment** quoted in Section 1 of the **Permit for Work** and fixed **Earthing Devices** or applied **Drain Earths** quoted on any **Earthing Schedule**.

The **Competent Person** clearing the **Permit for Work** shall sign and print their names and enter the date time and date of the clearance.

*Write N/A if not applicable

No	
----	--

Identify the **Location** of the **Equipment**

For work on an overhead line – the circuit name and voltage of the **Isolated** section of the line must be the same as that on the OHL technical data sheet.
For work in a Substation – name of Substation and the voltage

Identify **Equipment** to be worked on.

For work on an overhead line, record the **Circuit Identification** colours or symbols and the tower number include the route designation as per the OHL technical data sheet. Do not use abbreviated circuit colours

All **Points of Isolation** and their geographical **Location** shall be included.

Where the integrity of a **Point of Isolation** is dependent on SF6 gas at the designated density, the statement "IGDD" (Isolation Gas Density Dependent) shall be recorded against the **Point of Isolation** and the **Control Person(s) Safety** shall be informed of the name and contact detail of the **Competent Person** receiving the **Permit for Work** (see also document transfer guidance)

All relevant **Primary Earths** shall be identified with their geographical **Location**.

Include all precautions to avoid **System(s)** derived hazards which are to be taken during the work.

- If the DAR on the adjacent circuit is to be switched out during the work this should be specified
- Refer to drain **Earth Schedules** and cross reference control of Double DrESS earthing schemes see NSI4 general requirements for further guidance.
- For the issue of **Multiple Safety Documents** refer to NSI4 for further guidance.
- See guidance note for Cellular hazards

Cellular Installations.

Where Cellular installations are known, the best practice is to omit the relative towers from Section 1 of the main PFW and issue an additional safety document for the work on that specific tower on the day of the Cellular outage.

If this is not reasonably practicable then the requirement for Cellular precautions to maintain safety from the Cellular system can be documented in the Section Further precautions – A statement can also be inserted to ensure that no work commences until a Record of Cellular Isolation document has been issued. This information should also be recorded in the RAMS and detailed in the Toolbox Talk and recorded on the Toolbox Talk report form.

1. **LOCATION**.....

.....

EQUIPMENT IDENTIFICATION

.....

.....

WORK TO BE DONE

.....

.....

2. **PRECAUTIONS TAKEN TO ACHIEVE SAFETY FROM THE SYSTEM**

Point(s) of Isolation

.....

.....

Primary Earths*

.....

.....

Further precautions to avoid **System** derived hazards*

.....

.....

3. **PREPARATION** This **Permit for Work** shall be personally retained.

Control Person(s) (Safety) giving Consent		Key Safe Location & Number*	
Senior Authorised Person	Print Name	Signed	Time : Date / /

4. **ISSUE & RECEIPT**

Key Safe Key Number*		Card Safe* Procedure Number	
Circuit Identification Colour / Symbols*			
Earthing Schedule Number*	Portable Drain Earths* (number issued)	Flags* (number issued)	Wristlets* (number issued)
Senior Authorised Person	Print Name	Signed	Senior Authorised Person Mobile No*
Competent Person	Print Name	Signed	Time : Date / /
Company Name		Competent Person Mobile No*	

The **Senior Authorised Person** inserts the unique identifying number given by the **HV Control Person (Safety)** any pre-printed number shall be obliterated

The description shall make clear the extent of the work which is permitted in relation to the precautions described in Section 2

A **Working Party** register shall be issued along with any **Safety Document**, this negates the need to reference any method statement in Section one of the **Safety Document** as the **Working Party** register incorporates this information.

General Considerations

All **Safety Documents** shall be completed clearly and legibly, Block Capitals are recommended.

The **Senior Authorised Person** shall ensure abbreviations are understood by the **Competent Person** receiving the **Safety Document**.

The **Senior Authorised Person** completing **Safety Documents** shall ensure the precise requirements of each section are met indicating that all sections have been given consideration by entering the full details required or N/A.

Alterations on **Safety Documents** should wherever possible be avoided; they are not acceptable in Section 1. Alterations to other sections shall be completed by the obliteration of the complete word or item to be changed; all changes should be initialled by the **Senior Authorised Person**.

When the preparation section is completed and signed alterations to the contents are not permitted.

If Earth conductor is to be replaced as part of the work, Section 2 shall be endorsed with the following:

'No work shall be undertaken on the phase conductors, insulators or associated fittings in the section being worked on unless the earthwire is tensioned and permanently made off at both ends and electrically bonded to the towers in the section. This will ensure that the earthwire continuity is maintained throughout the route'

See NSI4 section 2B.

Use of OHL Permit for Work

There is no requirement for the OHL **Permit for Work** to be exclusively used for OHL work. When substation or cable work requires that **Circuit Identification** colour / symbols are quoted or there is a need to issue flags / wristlets the OHL **Permit for Work** may be the most appropriate **Safety Document** for a **Senior Authorised Person** to use.

Names of **Control Person(s) (Safety)** giving **Consent**. This provides confirmation that the **Equipment** released for work has been correctly identified in Section 1.

For **HV Equipment**, It confirms that the safety precautions stated in Section 2 for which the **Control Person(s) (Safety)** is responsible have been carried out and that procedures have been put in place to maintain these until the **Permit for Work** has been cancelled.

The **Senior Authorised Person** preparing the **Permit for Work** shall print, sign, time and date the **Permit for Work**. This confirms that **Consent** has been given by the **Control Person(s) (Safety)**.

The **Senior Authorised Person** issuing the **Permit for Work** shall Record:

- The **Key Safe Key** Number
- The items to be issued to the recipient

Then print their name and sign the **Permit for Work**

The **Permit for Work** shall be received by a **Competent Person** authorised to carry out the work in Section 1

The recipient will print, sign, insert contact detail, time and date this Section of the **Permit for Work** confirming their understanding of the **Safety Document** and its requirements and receipt of the items listed and Procedures detailed within this Section of the **Permit for Work**.

Delete as appropriate *Write N/A if not applicable

nationalgrid

OHL PERMIT FOR WORK

If during the course of work, additional work is identified that is not specified in Section 1, a **Senior Authorised Person** shall be consulted. He shall assess the implications of the additional work with regard to the **Isolated System** and **Safety from the System** (see **Safety Document** procedure P7).

If the **Senior Authorised Person** decides that the Additional Work requires extra **Drain Earths** or the issue of a new **Earthing Schedule** or Flag / Wristlets this shall be included here

Fixed **Earthing Devices** may used on the additional Drain **Earthing Schedule**

The **Senior Authorised Person** authorises the additional work by printing and signing their name

The **Competent Person** will print, sign, time and date the Acknowledgement section to confirm receipt of the listed items and their understanding of the contents and addition requirements of the **Permit for Work**

5. ADDITIONAL WORK SUBSEQUENT TO ISSUE
Equipment Identification and Work

.....

.....

.....

Additional Earthing Schedule Number*		Wristlets*	Additional No. issued	Total now issued	
Drain Earths *	Additional No issued	Total now issued	Circuit ID Flags*	Additional No. issued	Total now issued
Senior Authorised Person	Print Name	Signed			
Competent Person	Print Name	Signed	Time :	Date / /	

6. TRANSFER RECORD

PART 1 SURRENDER BY		PART 2 RE-ISSUE			
Competent Person	TIME DATE	Senior Authorised Person	TIME DATE	Competent Person	TIME DATE
Print Name		Print Name		Print Name	
Signed		Signed		Signed	
Mobile No*		Mobile No*		Mobile No*	
Print Name		Print Name		Print Name	
Signed		Signed		Signed	
Mobile No*		Mobile No*		Mobile No*	
Print Name		Print Name		Print Name	
Signed		Signed		Signed	
Mobile No*		Mobile No*		Mobile No*	
Print Name		Print Name		Print Name	
Signed		Signed		Signed	
Mobile No*		Mobile No*		Mobile No*	

7. CLEARANCE This **Permit for Work** is cleared, the following exceptions are recorded
 Confirm the operational state of **Equipment** quoted in Section 1 and any **Drain Earths** that remain applied as quoted on an **Earthing Schedule***

.....

.....

.....

Competent Person	Print Name	Signed	Time :	Date / /	
Company Name					

9. CANCELLATION

Control Person(s) (Safety)		Informed of cancellation and any restriction on return to Operational Service			
Senior Authorised Person	Print Name	Signed	Time :	Date / /	

*Write N/A if not applicable

The **Competent Person** transferring the **Permit for Work** shall sign, print, time and date Part 1 of the Transfer Record. Before signing the Transfer, the **Competent Person** shall ensure:

- The work area and all **Equipment** being worked on are left in a safe condition.
- That a Status of Transfer form is completed detailing the stage of the work.
- All individuals in his **Working Party** have been withdrawn from the work area and warned not to re-continue work on the **Equipment** concerned.

If the **Permit for Work** is not to be immediately re-issued the **Permit for Work** and associated documentation, **Keys** and items listed in Section 4 shall be deposited in a secure place as specified in the Safety Rules Guidance information.

Where the integrity of a **Point of Isolation** is dependent on SF6 gas at the designated density, the **Control Person(s) (Safety)** shall be informed of the transfer and the name of the new **Competent Person** and his contact information.

Permit for Work shall only be re-issued by a **Senior Authorised Person**. The transfer shall be to the same standard as the original issue.

The **Competent Person** shall ensure that all individuals in the **Working Party** have been withdrawn from, and warned not to re-continue work on the **Equipment** concerned. In addition all gear, tools, **Drain Earths** and loose materials shall have been removed and access gates are replaced and secured.

The **Competent Person** shall record any exceptions and any outstanding restrictions on the return to **Operational Service**. The **Competent Person** shall also confirm the operational state of **Equipment** quoted in Sections 1 of the **Permit for Work** and applied **Drain Earths** quoted on any **Earthing Schedule**

E.g.: **Drain Earths** are applied to tower xxx and are suitably rated to be used as an OHL **Primary Earth**'

The **Senior Authorised Person** shall sign and print their name then enter the time and date that the **Control Person(s) (Safety)** is informed of the cancellation of the **Permit for Work** with any exceptions and any outstanding restrictions on the return to **Operational Service**. The **Senior Authorised Person** shall also confirm the operational state of: **Equipment** quoted in Sections 1 of the **Permit for Work** and **Fixed Earthing Devices** or applied **Drain Earths** quoted on any **Earthing Schedule**

nationalgrid SANCTION FOR WORK

No

Identify the **Location(s)** of the **Equipment**.

For work in a Substation – name of substation and the voltage.

For work on an overhead line, not within a site boundary, the circuit name and voltage of the **Isolated** section of the line.

For work on a cable, not within a site boundary, the name and voltage of the circuit.

Identify **Equipment** to be worked on.

- The identification quoted should be the same as that on the **Equipment** itself.
- For work on a cable circuit, where appropriate refer to joint bay/link pit numbers, sealing ends or terminal towers.
- For work on an overhead line, record the **Circuit Identification** colours or symbols and the tower number which shall include the route designation.

All **Point(s) of Isolation** and their geographical location shall be included if remote from the **Location** of the work.

- Where the integrity of a **Point of Isolation** is dependent on SF6 gas at the designated density, the statement "IGDD" (Isolation Gas Density Dependent) shall be recorded against the **Point of Isolation**.
- Point(s) of Isolation** that may be restored under Restoration of Motive Power shall also be included.

Include all precautions to avoid **System** derived hazards which are to be taken during the work.

- Specify any stored energy that is safely contained but shall be released either before the work commences or during the course of the work.
- The precautions to be taken to release this stored energy shall be specified.
- If the DAR on the adjacent circuit is to be switched out during the work this should be specified.
- Refer to any **Earthing Schedule** issued.

Record the **Point(s) of Isolation** which may be varied by the recipient of the **Sanction for Work**.

Point(s) of Isolation from the **HV System** shall not be resorted.

Also record the **Primary Earths** that may be removed and replaced by the recipient of the **Sanction for Work**.

For **Approved** ROMP work details of the motive power that may be restored under the **Approved** procedure by the recipient of **Permit for Work** shall be recorded.

Names of **Control Person(s) (Safety)** giving **Consent**. This provides confirmation that the **Equipment** released for work has been correctly identified in Section 1.

For **HV Equipment**, It also confirms that the safety precautions stated in Section 2 for which the **Control Person(s) (Safety)** is responsible have been carried out and that with the exception of those precautions quoted in Section 3, procedures have been put in place to maintain these until the **Sanction for Work** has been cancelled.

The **Senior Authorised Person** preparing the **Sanction for Work** shall print, sign, time and date the **Sanction for Work**.

1. **LOCATION**.....

EQUIPMENT IDENTIFICATION

.....

WORK TO BE DONE

.....

2. **PRECAUTIONS TAKEN TO ACHIEVE SAFETY FROM THE SYSTEM**

Point(s) of Isolation

.....

Primary Earths

.....

Actions taken to avoid **Danger** by draining, venting, purging and containment or dissipation of stored energy*

.....

Further precautions to be taken during the course of the work to avoid **System** derived hazards*

.....

3. **PRECAUTIONS THAT MAY BE VARIED***

.....

4. **PREPARATION** This **Sanction for Work** shall be personally retained.

Control Person(s) (Safety) giving Consent		Key Safe Number*	
Senior Authorised Person	Print Name	Signed	Time : Date / /

5. **ISSUE & RECEIPT**

Approved ROMP# / SFW# Procedure Number(s)*		Key Safe Key Number*	
Safety Keys (number issued)*	Earthing Schedule Number*	Portable Drain Earths (number issued)*	
Circuit Identification Colours Symbols*		Flags (number issued)*	Wristlets (no issued)*
Senior Authorised Person	Print Name	Signed	Senior Authorised Person Mobile No*
Competent Person	Print Name	Signed	Time : Date / /
Company Name		Competent Person Mobile No*	

The **Senior Authorised Person** inserts the unique identifying number given by the **HV Control Person (Safety)**.

The description shall make clear the extent of the work which is permitted in relation to the precautions described in Section 2.

A **Working Party** Register shall be issued along with any **Safety Document**; this negates the need to reference any method statement in Section 1 of the **Safety Document** as the **Working Party** Register incorporates this information.

All relevant **Primary Earths** shall be identified with their geographical location if remote from the **Location** of the work.

Action taken to drain, vent or purge **Equipment** and contain or dissipate stored energy shall be included.

General Considerations

All **Safety Documents** shall be completed clearly and legibly, Block Capitals are recommended.

The **Senior Authorised Person** shall ensure abbreviations are understood by the **Competent Person** receiving the **Safety Document**.

The **Senior Authorised Person** completing **Safety Documents** shall ensure the precise requirements of each section are met indicating that all sections have been given consideration by entering the full details required or N/A.

Alterations on **Safety Documents** should wherever possible be avoided; they are not acceptable in Section 1. Alterations to other sections shall be completed by the obliteration of the complete word or item to be changed; all changes should be initialled by the **Senior Authorised Person**.

When the preparation section is completed and signed alterations to the contents are not permitted.

There shall be no undue delay between the time and date of preparation, issue and receipt.

The **Competent Person** shall be set to work by the **Senior Authorised Person**.

The **Senior Authorised Person** issuing the **Sanction for Work** shall Record:

- The **Key Safe Key** Number
- Any **Approved Sanction for Work** or ROMP procedure numbers
- The items to be issued to the recipient

The **Senior Authorised Person** then prints their name and signs the **Sanction for Work**.

The **Sanction for Work** shall be received by a **Competent Person** authorised to carry out the work in Section 1 and/or vary the precautions in Section 3.

The recipient will print, signs, time and date this section of the **Sanction for Work** confirming their understanding of the **Safety Document** and its requirements and receipt of the items listed and procedures detailed within this section of the **Sanction for Work**.

#Delete as appropriate *Write N/A if not applicable

nationalgrid SANCTION FOR WORK

If during the course of work, additional work is identified that is not specified in Section 1, a **Senior Authorised Person** shall be consulted. He shall assess the implications of the additional work with regard to the **Isolated System** and **Safety from the System**.

If the **Senior Authorised Person** decides that the additional work requires extra **Drain Earths** or the issue of a new **Earthing Schedule** this shall be included here.

Fixed **Earthing Devices** may be used on an additional **Earthing Schedule**.

The **Senior Authorised Person** authorises the additional work by printing and signing their name.

The **Competent Person** will print, sign, time and date the Acknowledgement section to confirm receipt of the listed items and their understanding of the contents and addition requirements of the **Sanction for Work**.

The **Working Party** Register shall be updated if there are significant changes to the methods of work, these changes must be communicated via the tool box talk process.

6. ADDITIONAL WORK SUBSEQUENT TO ISSUE

Equipment Identification and Work

.....

.....

Additional Earthing Schedule Number*		Drain Earths	Additional No. issued	Total now issued
Senior Authorised Person	Print Name	Signed		
Competent Person	Print Name	Signed	Time : / /	Date / /

7. TRANSFER RECORD

PART 1 SURRENDER BY		PART 2 RE-ISSUE		
Competent Person		Senior Authorised Person	Competent Person	TIME DATE
Print Name	Print Name	Print Name	Print Name	
Signed	Signed	Signed	Signed	
Mobile No*	Mobile No*	Mobile No*	Mobile No*	
Print Name	Print Name	Print Name	Print Name	
Signed	Signed	Signed	Signed	
Mobile No*	Mobile No*	Mobile No*	Mobile No*	
Print Name	Print Name	Print Name	Print Name	
Signed	Signed	Signed	Signed	
Mobile No*	Mobile No*	Mobile No*	Mobile No*	
Print Name	Print Name	Print Name	Print Name	
Signed	Signed	Signed	Signed	
Mobile No*	Mobile No*	Mobile No*	Mobile No*	
Print Name	Print Name	Print Name	Print Name	
Signed	Signed	Signed	Signed	
Mobile No*	Mobile No*	Mobile No*	Mobile No*	

8. CLEARANCE

This **Sanction for Work** is cleared, the following exceptions are recorded

Confirm the operational state of **Equipment** quoted in Section 1 & 3, also any **Drain Earths** that remain applied as quoted on an **Earthing Schedule***

.....

.....

Competent Person	Print Name	Signed	Time : / /	Date / /
Company Name				

9. CANCELLATION

Control Person(s) (Safety)		Informed of cancellation and any restriction on return to Operational Service		
Senior Authorised Person	Print Name	Signed	Time : / /	Date / /

The **Senior Authorised Person** shall sign and print their name then enter the time and date that the **Control Person(s) (Safety)** informed of cancellation of the **Sanction for Work** with any exceptions and any outstanding restrictions on the return to **Operation Service**.

The **Senior Authorised Person** shall also confirm to the **Control Person(s) Safety** the operational state of: **Equipment** quoted in Sections 1 of the **Sanction for Work** and fixed **Earthing Devices** or applied **Drain Earths** quoted on any **Earthing Schedule**.

Sanction for Work shall only be re-issued by a **Senior Authorised Person**. The transfer shall be to the same standard as the original issue. Both **Competent Persons** involved in the transfer process and the **Senior Authorised Person** will ensure all aspects of the work are discussed to ensure the **Senior Authorised Person** and **Competent Person** receiving the document full understands all aspects of the work.

The **Competent Person** transferring the **Sanction for Work** shall sign and print Part 1 of the Transfer Record. Before signing the Transfer, the **Competent Person** shall ensure:

- The work area and all **Equipment** being worked on are left in a Safe condition.
- All individuals in his **Working Party** have been withdrawn from the work area and warned not to re-continue work on the **Equipment** concerned.

When a **Sanction for Work** is to be transferred by a **Senior Authorised Person** both the new recipient and the person surrendering the document shall be present to the time of transfer.

Where the integrity of a **Point of Isolation** is dependent on SF6 gas at the designated density, the **Control Person(s) (Safety)** shall be informed of the transfer and the name of the new **Competent Person** and his contact information.

The **Competent Person** shall ensure that all individuals in the **Working Party** have been withdrawn from, and warned not to re-continue work on the **Equipment** concerned. In addition all gear, tools, **Drain Earths** and loose materials shall have been removed and guards and access doors replaced.

The **Competent Person** shall record any exceptions and any outstanding restrictions on the return to **Operation Service**. The **Competent Person** shall also confirm the operational state of: **Equipment** quoted in Section 1 of the **Sanction for Work** and fixed **Earthing Devices** or applied **Drain Earths** quoted on any **Earthing Schedule**.

The **Competent Person** clearing the **Sanction for Work** shall sign and print their name and enter the time and date of the clearance.

There shall be no undue delay between the time and date of clearance and cancellation, issue and receipt.

The **Senior Authorised Person** shall be informed of the operational state of the **Equipment** and any exceptions by the **Competent Person**.

*Write N/A if not applicable

No	
----	--

A unique pre-printed number is provided. This number is used when the **Safety Document** is issued.

Identify the **Location** of the **Equipment**.
Name the Substation and the voltage.

Identify the **Equipment** to be worked on or near to.
The **Equipment** identification quoted should be the same as that on the **Equipment** itself, record the circuit name, or if identified by symbols, described the symbols and state the colour code. When safety precautions are established on **Equipment** to facilitate work on *Plant* or any structure(s), which are not part of the **System** the **Equipment** to which the safety precautions have been established shall be identified see P4.1 guidance for details.

The description shall make clear the extent of the work which is permitted.
A **Working Party** Register shall be issued along with any **Safety Document**; this negates the need to reference any method statement in Section 1 of the **Safety Document** as the **Working Party** Register incorporates this information.

The **Senior Authorised Person** shall justify:
a) It is unreasonable in all circumstances for it to be **Dead**; and
b) It is reasonable in all circumstances to be at work on or near it while it is **Live**.

State the significant hazards that have been identified in the Risk Assessments produced for the work. These should include where appropriate:
System voltage
Energy level
Working Space
Lighting levels
Noise levels
Obstructions
Tripping hazards etc.

The **Senior Authorised Person** issuing the **Certificate For Live LV Work** shall Record:
• The **Key Safe Key** Number, if applicable
• The items and procedures to be issued to the recipient
The **Senior Authorised Person** then prints their name and signs the **Certificate For Live LV Work**.
The **Certificate For Live LV Work** shall be received by a **Competent Person** authorised to carry out the work in Section 1.
The recipient will print, signs, time and date this section of the **Certificate For Live LV Work** confirming their understanding of the **Safety Document** and its requirements and receipt of the items listed and procedures detailed within this section of the **Certificate For Live LV Work**.

1. **LOCATION**.....
EQUIPMENT IDENTIFICATION
.....
WORK TO BE DONE
.....

2. **JUSTIFICATION FOR WORKING LIVE**
.....

3. **HAZARDS** The following hazards have been identified and assessed
.....

4. **PRECAUTIONS TO BE TAKEN TO ESTABLISH A SAFE SYSTEM OF WORK**
Point(s) of Isolation*
List controls established as part of the safe system of work (e.g. Insulated Screening, Insulated Tools, and PPE etc.)
.....
Specific instructions to be followed in the event of an emergency
.....

5. **PREPARATION** This **Certificate For Live LV Work** shall be personally retained

Control Person(s) (Safety) giving Consent		Key Safe Number*	
Senior Authorised Person	Print Name	Signed	Time : Date / /

6. **ISSUE & RECEIPT**

Procedure Number(s)*			
Safety Keys (number issued)*	Sketch Provided # YES / NO	Key Safe Key Number*	
Senior Authorised Person	Print Name	Signed	Senior Authorised Person Mobile No*
Competent Person	Print Name	Signed	Time : Date / /
Company Name		Competent Person Mobile No*	

LIVE LV WORKING
Where reasonably practicable the preferred method is to work on or near to **LV Equipment**, which is **Dead**. Work on or near to **Live LV Equipment** should rarely be permitted.
Regulation 14 of the Electricity at Work Regulations 1989 lays down the following process that shall be followed before **Live** working can be carried out.
No person shall be engaged in any work on or so near any **Live** conductor that **Danger** may arise unless:
a) It is unreasonable in all circumstances for it to be **Dead**; and
b) It is reasonable in all circumstances to be at work on or near it while it is **Live**; and
c) Suitable precautions (including where necessary the provision of suitable protective equipment) are taken to prevent injury.
The above three conditions shall all be met for **Live** working to be permitted where **Danger** may arise. If just one of the conditions cannot be met, **Live** working cannot be permitted and **Dead** working is essential.

Demonstrate that suitable precautions are taken to prevent injury.
Include **Point(s) of Isolation** on **Equipment** made **Dead**.
List the **Equipment** required as part of the safe system of work. This should include where appropriate:
• Insulated screening and/or protective barriers.
• Personal protective equipment that must be used.
• Insulated Tools.
• Etc.
Summarise the precautions established and actions to be followed in the event of an emergency. If applicable state the position of switches, fuses or links making the circuit **Dead** if required.

There must be no undue delay between the time and date of preparation, issue and receipt.
The **Competent Person** must be set to work by the **Senior Authorised Person**.

General Considerations
All **Safety Documents** shall be completed clearly and legibly, Block Capitals are recommended.
The **Senior Authorised Person** shall ensure abbreviations are understood by the **Competent Person** receiving the **Safety Document**.
The **Senior Authorised Person** completing **Safety Documents** shall ensure the precise requirements of each section are met indicating that all sections have been given consideration by entering the full details required or N/A.
Alterations on **Safety Documents** should wherever possible be avoided; they are not acceptable in Section 1. Alterations to other sections shall be completed by the obliteration of the complete word or item to be changed; all changes should be initialled by the **Senior Authorised Person**.
When the preparation section is completed and signed alterations to the contents are not permitted.

#Delete as appropriate *Write N/A if not applicable

nationalgrid CERTIFICATE FOR LIVE LV WORK

7. SKETCH*

This section can be used by the **Senior Authorised Person** to clarify the work or work area with a sketch.

8. TRANSFER RECORD

PART 1 SURRENDER BY		PART 2 RE-ISSUE	
Competent Person	Senior Authorised Person	Competent Person	TIME DATE
Print Name	Print Name	Print Name	
Signed	Signed	Signed	
Mobile No*	Mobile No*	Mobile No*	
Print Name	Print Name	Print Name	
Signed	Signed	Signed	
Mobile No*	Mobile No*	Mobile No*	
Print Name	Print Name	Print Name	
Signed	Signed	Signed	
Mobile No*	Mobile No*	Mobile No*	
Print Name	Print Name	Print Name	
Signed	Signed	Signed	
Mobile No*	Mobile No*	Mobile No*	
Print Name	Print Name	Print Name	
Signed	Signed	Signed	
Mobile No*	Mobile No*	Mobile No*	

Certificate For Live LV Work shall only be re-issued by a **Senior Authorised Person**. The transfer shall be to the same standard as the original issue. Both **Competent Persons** involved in the transfer process and the **Senior Authorised Person** will ensure all aspects of the work are discussed to ensure the **Senior Authorised Person** and **Competent Person** receiving the document fully understands all aspects of the work.

The **Competent Person** transferring the **Certificate For Live LV Work** shall sign, print, Part 1 of the Transfer Record. Before signing the Transfer, the **Competent Person** shall ensure:

- The work area and all **Equipment** being worked on are left in a safe condition.
- All individuals in his **Working Party** have been withdrawn from the work area and warned not to re-continue work on the **Equipment** concerned.

When the **Certificate For Live LV Work** is to be transferred by a **Senior Authorised Person** both the new recipient and the person surrendering the document shall be present to the time of transfer.

9. CLEARANCE This **Certificate For Live LV Work** is cleared with the following recorded exceptions or limitations *

.....

.....

.....

.....

.....

.....

.....

The **Competent Person** clearing the **Certificate for Live LV Work** shall ensure that all other **Competent Person(s)** in the **Working Party** have been withdrawn from, and warned not to re-continue work on the **Equipment** concerned. In addition all gear, tools, and loose materials must have been removed and guards and access doors replaced.

The **Competent Person** shall record any exceptions and any outstanding restrictions on the return to **Operation Service**. The **Competent Person** shall also confirm the operational state of: **Equipment** quoted in Section 1 of the **Certificate for Live LV Work**.

The **Competent Person** clearing the **Certificate for Live LV Work** shall sign and print their names and enter the date time and date of the clearance.

Competent Person	Print Name	Signed	Time	Date
			:	/ /
Company Name				

There must be no undue delay between the time and date of clearance and cancellation.

The **Senior Authorised Person** must be informed of the condition of the equipment and any exceptions by the **Competent Person**.

10. CANCELLATION

Control Person(s) (Safety) Informed of cancellation and any restriction on return to **Operational Service**

Senior Authorised Person	Print Name	Signed	Time	Date
			:	/ /

The **Senior Authorised Person** must print their name, sign and enter the date and time of cancellation of the **Certificate for Live LV Work**.

*Write N/A if not applicable

Earthing Schedule guidance for OHL

EARTHING SCHEDULE

Location.
Details for **Location** should be entered as they are in Section 1 of the accompanying **Safety Document** eg: **Permit for Work - Circuit Identification**, Voltage (132-275-400kV) Over Head Line.

Equipment / Circuit.
Details entered should match information in Section 1 of the **Safety Document**

Scheme or Stage.
Details entered in this box should reflect the following:
Scheme - Enter the Scheme number that is relevant to the work being carried out referenced in NSI 4.
Stage - If the type of work is not found under a scheme in NSI 4 then enter the Stage Number or details that have been identified in a specific Method Statement (or other approved procedure) for the work to be carried out. The work must also be within the scope of NSI 4.
Job Number - If a Job Number is entered then the Work Description section must reflect the work and earthing process in greater detail and be within the scope of NSI 4.

Sketch / Remarks.
This section can be used to show:
Where the **Senior Authorised Person** would like the tower/s to be demarcated with Red Pennants by drawing a sketch.
Making reference to Method Statements, drawing an **Earthing Scheme** for reduced earthing etc.
Detailing other associated Items issued with a DrESS scheme such as quantity of Connecting Bonds and Sparrow Plates etc.
Making reference to approved Earthing Schemes detailed in a separate document and attached to the **Earthing Schedule**

Issue.
Senior Authorised Person to Sign, enter Time and Date, on issuing to recipient of **Safety Document**

Cancellation.
Senior Authorised Person to Sign, enter Time and Date on cancellation of **Safety Document**

Location	Associated Safety Document Number
Equipment/Circuit	

POSITION OF **DRAIN EARTHS** AT EACH STAGE OF WORK

NOTES: - Work shall not commence on any stage until the earthing requirements for that stage have been completed.

Scheme, Stage or Job No.	Work Description	DRAIN EARTHS	
		Location	Number
NSI 4 Scheme 8	EMI 898 Suspension Insulator Replacement.	Twrs 4XX 14, 18 and 22.	12
NSI 4 Scheme 1	EMI 850 Spacer Replacement.	SAP to identify all towers to be Earthed.	48
		SAP must take into consideration that sufficient Drain Earths are made available in order to manage unplanned access and egress to towers, within the section. (e.g: Bad weather, Tower Rescue etc)	
NSI 4 - 1.4 (1.4.2.6)	Spare Earths-Ref: NSI 4 Application and Removal of Earths (Damaged etc)	AS ABOVE	2

SKETCH/REMARKS/OHL CONTRACTORS EARTHING SCHEDULE

Number of Portable Earths Issued:

Normal	50
Temporary Earth Bonds NSI 24	
Short Drain	
Bridging	
Running	
Earthing Bridles	
Others	
Total issued	50
Fixed Earthing Devices	

(Use should be specified in Work Description)

ISSUE (Signed) _____ TIME: : DATE: / /

Senior Authorised Person

CANCELLATION (Signed) _____ TIME: : DATE: / /

Senior Authorised Person

unique pre-printed number. This number is not to be crossed out. It should be referenced to the **Safety Document**
If other towers need to be worked on and they are not on the original **Earthing Schedule** then another **Safety Document** and **Earthing Schedule** should be taken out and issued.

Associated **Safety Document** Number. Enter the Unique number in this box that was issued during the process of taking the **Safety Document** out and that is recorded on the **Safety Document**

Location.
The **Location** of **Drain Earths** will be the towers of where they are applied. Therefore every tower number is to be entered in this box linking them to the Scheme, Stage or Work Description.
Note: If extra work is required on towers that are not listed on the original **Earthing Schedule**, but the work mirrors the work already being carried out on towers listed, then an additional **Earthing Schedule** is to be produced and added to the existing **Safety Document**

Number.
The number of **Drain Earths** required for each Scheme / Job is to be entered in this box. The total actually issued to the recipient does not necessarily have to match the quantity stated alongside each Scheme or Stage. It depends on other criteria such as how many members are in the Working Party and if they will work as 2 teams etc.

Eg: If more than one scheme is being implemented and they all require different numbers of **Drain Earths** then the total per scheme will reflect this. The number issued will be the scheme that requires the most **Drain Earths**. The **Senior Authorised Person** will agree these issues with the **Competent Person** prior to the **Safety Document(s)** being issued.

Number of Earths.
State quantities of all earths accordingly.
1, All Earths to be tested prior to use and recorded. Also Earths are to be labelled with their individual numbers or ID markings.
2, **Drain Earth** Control procedure (DEC) should be considered to be implemented for all works.

Work on Earth Wire under a **Limited Access Certificate**
Senior Authorised Person to ensure an **Earthing Schedule** is issued with an LAC. In doing so he must record the number of Short **Drain Earths** issued in the Short **Drain Earth** Box.
The **Earthing Schedule** must also include clear details regarding any NSI's, Schemes, Stages or Method Statements that are to be implemented prior to any work commencing.
The **Earthing Schedule** number must be recorded on the **Limited Access Certificate**

NOTES:
If there is not a relevant Earthing Scheme within NSI 4 then a Scheme or Stage of works should be prepared by the **Senior Authorised Person** and forwarded to an OHL Engineer, using form F1 - OHL Engineers Report, for approval. **Reference NSI 4 - Appendix C for F1 Form**
Where the Earthing Schemes could be of a more complex nature the **Senior Authorised Person** should consider the use of the 'OHL Earthing Schedule for use on Complex / Refurbishment Work'

NATIONAL GRID OVERHEAD LINES
OHL Earthing Schedule for use on complex work such as
 refurbishment work or some maintenance work

LOCATION: HEYSHAM-HUTTON-PENWORTHAM N° 2 CIRCUIT 400Kv OHL	ASSOCIATED SAFETY DOCUMENT No.	Earthing Schedule Number: HHP2/ZX/2008
EQUIPMENT / CIRCUIT	TOWERS 4TC26, ZX344, ZX345R, ZX346 to ZX350, CIRCUIT IDENTIFICATION YELLOW. TOWERS ZX351 to ZX381, ZX381A, ZX382 to ZX418, ZX418A, ZX419 to ZX439, ZX440R, ZX441R, ZX442R, ZX443R CIRCUIT IDENTIFICATION RED/WHITE.	

NOTE-WORK MUST NOT COMMENCE ON ANY STAGE UNTIL THE EARTHING REQUIREMENTS FOR THAT STAGE HAVE BEEN COMPLETE

Stage	WORK DESCRIPTION	EARTHING REQUIREMENTS
1	Application of drain earths at towers adjacent to section being worked in. (boxing in towers)	NSI4 Scheme XX Towers 4TC26, ZX344, ZX415, ZX431, ZX437.
2	Application and movement of drain earths at suspension towers for conductor running. NOTE See section 8 for semi tension and suspended tension towers after pulling conductors. ZX363, ZX381. ZX354, ZX394, ZX387.	NSI4 Scheme XX Towers ZX346, ZX347, ZX348, ZX349, ZX351, ZX352, ZX354, ZX355, ZX356, ZX358, ZX359, ZX360, ZX361, ZX362, ZX363, ZX364, ZX365, ZX366, ZX367, ZX369, ZX370, ZX371, ZX372, ZX374, ZX375, ZX376, ZX377, ZX379, ZX380, ZX381, ZX381A, ZX382, ZX383, ZX384, ZX386, ZX387, ZX389, ZX390, ZX392, ZX393, ZX394, ZX395, ZX397, ZX398, ZX399, ZX400, ZX401, ZX402, ZX403, ZX404, ZX406, ZX407, ZX408, ZX409, ZX411, ZX412, ZX413, ZX433, ZX434.
3	Initial application of drain earths at a puller/tensioner tower.	NSI4 Scheme XX Towers ZX345R, ZX357, ZX373, ZX385, ZX391, ZX396, ZX410, ZX414, ZX432, ZX436.
4	Application and removal of drain earths applied from a platform at a puller/tensioner tower prior to pulling conductors.	NSI4 Scheme XX Towers ZX345R, ZX357, ZX373, ZX385, ZX391, ZX396, ZX410, ZX414, ZX432, ZX436.
5	Application and removal of drain earths at a puller/tensioner tower from a platform after pulling conductors.	NSI4 Scheme XX Towers ZX345R, ZX357, ZX373, ZX385, ZX391, ZX396, ZX410, ZX414, ZX432, ZX436.
6	Initial application of drain earths at a pull through tower.	NSI4 Scheme XX Towers ZX350, ZX353, ZX368, ZX378, ZX388, ZX405, ZX435
7	Application and removal of drain earths applied from a platform at a pull through tower prior to pulling conductors.	NSI4 Scheme XX Towers ZX350, ZX353, ZX368, ZX378, ZX388, ZX405, ZX435.

Notes:
 Allocate a unique number e.g. abbreviated circuit / route / year; this must be cross referenced on the associated **Safety Document(s)**.
Location and **Equipment** :- Circuit must be the same as that stated on the associated **Safety Document(s)**.
 Item: There may be more or less items dependent on the complexity of the work, e.g. :- Fittings only, Earth Conductor to be run, Phase conductors to be run, these lines may be added or deleted as required.
 Work description: Refer to the scheme description and insert any relevant instruction that may be required to achieve each stage of the work.
 Earthing requirements: Always quote the scheme number and list all towers affected for the particular scheme and stage.

This refurbishment **Earthing Schedule** will normally be issued with a Multiple **Safety Document**, therefore all **Drain earths** may be issued with the master Permit for Work and controlled with the DEC system, in this case all secondary refurbishment **Earthing Schedules** should be issued as copies and endorsed with the following, "All **Drain Earths** issued with Master Permit for work Ref No xxxxxxxxxx.
 This does not preclude the issue of a separate earthing schedule with associated Drain earths if the SAP or work requires it.
 Any other relevant instruction or information should be inserted here.
 Issued column: - insert the total amount of **Drain Earths** for each heading i.e. Normal, Bridging etc, insert N/A in any box not applicable. The total issued should be the sum of all **Drain Earths**.

SAP shall sign, time and date prior to issue.

8	Application and removal of drain earths at a pull through tower from a platform after pulling. Applies to semi tension and suspended tension towers.	NSI4 Scheme XX
9	Application and removal of drain earths for work on conductors and spacers from a conductor trolley.	NSI4 Scheme XX At towers where access to or egress from conductors is required and not more than 10 spans apart.
10	Application and removal of short drain earths for work on earthwire and fittings.	NSI4 Scheme XX At towers where access within 1m of earthwire and/or fittings is required.
11	Application and removal of drain earths for replacing crossarm steelwork.	NSI4 Scheme XX At towers where access to crossarms is required to replace steelwork.
# NOTE. ALL DRAIN EARTHS ISSUED WITH MASTER PERMIT FOR WORK REF No EQUIPOTENTIAL ZONES SHALL BE SET UP AT PULLER/TENSIONER SITES IN ACCORDANCE WITH NSI4 SCHEME 12 PRIOR TO CONDUCTOR PULLING.	NORMAL	1223
	BRIDGING	N/A
	RUNNING	16
	PLAT FORM APPLIED	60
	SHORT	170
	OTHERS	N/A
Total Issued		1469
Issued Senior Authorised Person	Date	Time
Cancellation Senior Authorised Person	Date	Time