

## Stage 04: Code Administrator Consultation

---

- Volume 4

Connection and Use of System Code (CUSC)

# CMP213 Project TransmiT TNUoS Developments

---

## Draft Legal Text

---

Published on: 10<sup>th</sup> April 2013

---

What stage is this document at?

01	Initial Written Assessment
02	Workgroup Consultation
03	Workgroup Report
04	Code Administrator Consultation
05	Draft CUSC Modification Report
06	Final CUSC Modification Report



## Contents

1. Draft Legal Text Overview
2. CMP213 Original Draft Legal Text
3. Diversity option 1 Draft Legal Text
4. Diversity option 2 Draft Legal Text
5. Diversity option 3 Draft Legal Text
6. Hybrid ALF Draft Legal Text
7. HVDC / Islands options Draft Legal Text

---

### Any Questions?

Contact:

**Adelle McGill**

---

Code Administrator



[adelle.mcgill@nationalgrid.com](mailto:adelle.mcgill@nationalgrid.com)



---

**01926 653142**

Proposer:

**Ivo Spreeuwenberg**

Company

---

**National Grid**

## About this document

This document contains the Draft legal text for CMP213.

## Document Control

Version	Date	Author	Change Reference
1.0	10 April 2013	Code Administrator	Publication to Industry

## 1 Draft Legal Text Overview

- 1.1 Volume 4 of the Code Administrator Consultation contains draft legal text of Section 14 of the CUSC for the CMP213 Original proposal and all Workgroup Alternatives.
- 1.2 In the case of Workgroup Alternatives, a matrix approach has been taken, with draft legal text being produced to cover the full range of Workgroup alternatives rather than each Workgroup alternative. Changes only from the original proposal are provided for ease of reference. These Alternative draft legal texts are;
  - Diversity option 1
  - Diversity option 2
  - Diversity option 3
  - Hybrid ALF
  - HVDC / Islands options
- 1.3 Table 1 below shows how each of these options relate to the Workgroup Alternatives raised.
- 1.4 For Diversity option 1, Diversity option 2, and Diversity option 3 full draft legal text is provided. Changes from the Original draft legal text are highlighted in yellow to aid comparison. This highlighting would be removed should these draft legal texts be accepted into the CUSC.
- 1.5 For Hybrid ALF, and HVDC / Islands options draft legal text is provided only for those sections altered from the Original draft legal text.

Main Components of CMP213	1	2	3	4	5	6	7	9	12	14	16	17	18	19	21	22	23	24	25	26	28	30	31	32	33	40
<b>Extent of Sharing</b>																										
Diversity Method 1		x			x			x	x		x			x			x			x		x			x	x
Diversity Method 2			x			x						x					x						x			
Diversity Method 3				x									x						x					x		
<b>Form of Sharing</b>																										
YR - Hybrid		x			x	x			x					x		x				x					x	x
<b>Parallel HVDC</b>																										
Specific EF; generic 40% Conv+100%Cable (AC sub + QB)							x	x	x	x	x	x	x	x												
Specific EF; generic 50% Conv+100%Cable (AC sub)																						x	x	x	x	x
Specific EF; specific x% Conv. cost reduction (AC sub)															x	x	x	x	x	x	x					
<b>Islands</b>																										
Specific EF; generic 30% Conv+100%Cable (AC sub + STATCOM)							x	x	x																	x
Specific EF; generic 50% Conv+100%Cable (AC sub)										x	x	x	x	x								x	x	x	x	x
Specific EF; specific x% specific Conv. cost reduction (AC sub)															x	x	x	x	x	x						

Table 1 – Matrix of draft legal texts for each WACM



## CUSC - SECTION 14

### CHARGING METHODOLOGIES

#### CONTENTS

Part 2 -The Statement of the Use of System Charging Methodology

Formatted: Font: Bold

Formatted: Centered

Deleted: ¶

Section 1 – The Statement of the Transmission Use of System Charging Methodology;

14.14 Principles

14.15 Derivation of Transmission Network Use of System Tariff

14.16 Derivation of the Transmission Network Use of System Energy Consumption Tariff and Short Term Capacity Tariffs

14.17 Demand Charges

14.18 Generation Charges

14.19 Data Requirements

14.20 Applications

14.21 Transport Model Example

14.22 Example: Calculation of Zonal Generation Tariffs [and Charges](#)

14.23 Example: Calculation of Zonal Demand Tariff

[14.24 Diagrams: Illustrative local transmission networks connected to the main NETS via single transmission circuits](#)

Formatted: Font: Arial, 12 pt

14.25 Reconciliation of Demand Related Transmission Network Use of System Charges

Deleted: 4

14.26 Classification of parties for charging purposes

Deleted: 5

14.27 Transmission Network Use of System Charging Flowcharts

Deleted: 6

14.28 Example: Determination of The Company's Forecast for Demand Charge Purposes

Deleted: 7

14.29 Stability & Predictability of TNUoS tariffs

Deleted: 8

Section 2 – The Statement of the Balancing Services Use of System Charging Methodology

14.30 Principles

Deleted: 29

14.31 Calculation of the Daily Balancing Services Use of System charge

Deleted: 0

14.32 Settlement of BSUoS

Deleted: 1

14.33 Examples of Balancing Services Use of System (BSUoS) Daily Charge Calculations

Deleted: 2

## CUSC - SECTION 14

### CHARGING METHODOLOGIES

14.1 Introduction

14.1.1 This section of the CUSC sets out the statement of the Connection Charging Methodology and the Statement of the Use of System Methodology

Formatted: Tabs: 2.77 cm,  
List tab + Not at 1.5 cm

Formatted: Tabs: 3.63 cm,  
List tab + Not at 3 cm

Formatted: 1,2,3, Justified,  
Indent: Left: 0 cm



## Part 2 - The Statement of the Use of System Charging Methodology

Deleted:  
Formatted: Font: Arial (W1)  
Deleted: ¶

### Section 1 – The Statement of the Transmission Use of System Charging Methodology

#### 14.14 Principles

**14.14.1** Transmission Network Use of System charges reflect the cost of installing, operating and maintaining the transmission system for the Transmission Owner (TO) Activity function of the Transmission Businesses of each Transmission Licensee. These activities are undertaken to the standards prescribed by the Transmission Licences, to provide the capability to allow the flow of bulk transfers of power between connection sites and to provide transmission system security.

Formatted: Indent: Left: 1.27 cm, Numbered + Level: 1 + Numbering Style: 1, 2, 3, ... + Start at: 1 + Alignment: Left + Aligned at: 0 cm + Tab after: 0 cm + Indent at: 1.6 cm, Tabs: 1.9 cm, List tab + Not at 0 cm + 1.27 cm

**14.14.2** A Maximum Allowed Revenue (MAR) defined for these activities and those associated with pre-vesting connections is set by the Authority at the time of the Transmission Owners' price control review for the succeeding price control period. Transmission Network Use of System Charges are set to recover the Maximum Allowed Revenue as set by the Price Control (where necessary, allowing for any  $K_t$  adjustment for under or over recovery in a previous year net of the income recovered through pre-vesting connection charges).

Formatted: Indent: Left: 1.27 cm, Numbered + Level: 1 + Numbering Style: 1, 2, 3, ... + Start at: 1 + Alignment: Left + Aligned at: 0 cm + Tab after: 0 cm + Indent at: 1.6 cm, Tabs: 1.9 cm, List tab + Not at 0 cm + 1.27 cm

**14.14.3** The basis of charging to recover the allowed revenue is the Investment Cost Related Pricing (ICRP) methodology, which was initially introduced by The Company in 1993/94 for England and Wales. The principles and methods underlying the ICRP methodology were set out in the The Company document "**Transmission Use of System Charges Review: Proposed Investment Cost Related Pricing for Use of System (30 June 1992)**".

Formatted: Indent: Left: 1.27 cm, Numbered + Level: 1 + Numbering Style: 1, 2, 3, ... + Start at: 1 + Alignment: Left + Aligned at: 0 cm + Tab after: 0 cm + Indent at: 1.6 cm, Tabs: 1.9 cm, List tab + Not at 0 cm + 1.27 cm

**14.14.4** In December 2003, The Company published the Initial Thoughts consultation for a GB methodology using the England and Wales methodology as the basis for consultation. The Initial Methodologies consultation published by The Company in May 2004 proposed two options for a GB charging methodology with a Final Methodologies consultation published in August 2004 detailing The Company's response to the Industry with a recommendation for the GB charging methodology. In December 2004, The Company published a Revised Proposals consultation in response to the Authority's invitation for further review on certain areas in The Company's recommended GB charging methodology.

Formatted: Indent: Left: 1.27 cm, Numbered + Level: 1 + Numbering Style: 1, 2, 3, ... + Start at: 1 + Alignment: Left + Aligned at: 0 cm + Tab after: 0 cm + Indent at: 1.6 cm, Tabs: 1.9 cm, List tab + Not at 0 cm + 1.27 cm

**14.14.5** In April 2004 The Company introduced a DC Loadflow (DCLF) ICRP based transport model for the England and Wales charging methodology. The DCLF model has been extended to incorporate Scottish network data with existing England and Wales network data to form the GB network in the model. In April 2005, the GB charging methodology implemented the following proposals:

Formatted: Numbered + Level: 1 + Numbering Style: 1, 2, 3, ... + Start at: 5 + Alignment: Left + Aligned at: 1.27 cm + Tab after: 1.27 cm + Indent at: 2.87 cm, Tabs: 1.9 cm, List tab + Not at 1.27 cm

i.) The application of multi-voltage circuit expansion factors with a forward-looking Expansion Constant that does not include substation costs in its derivation.

Formatted: Indent: Left: 2.54 cm, Numbered + Level: 1 + Numbering Style: i, ii, iii, ... + Start at: 1 + Alignment: Left + Aligned at: 1.27 cm + Tab after: 2.54 cm + Indent at: 2.54 cm, Tabs: Not at 1.27 cm + 2.54 cm

ii.) The application of locational security costs, by applying a multiplier to the Expansion Constant reflecting the difference in cost incurred on a secure network as opposed to an unsecured network.

Formatted: Indent: Left: 2.54 cm, Numbered + Level: 1 + Numbering Style: i, ii, iii, ... + Start at: 1 + Alignment: Left + Aligned at: 1.27 cm + Tab after: 2.54 cm + Indent at: 2.54 cm, Tabs: Not at 1.27 cm + 2.54 cm

- iii.) The application of a de-minimus level demand charge of £0/kW for Half Hourly and £0/kWh for Non Half Hourly metered demand to avoid the introduction of negative demand tariffs.
- iv.) The application of 132kV expansion factor on a Transmission Owner basis reflecting the regional variations in network upgrade plans.
- v.) The application of a Transmission Network Use of System Revenue split between generation and demand of 27% and 73% respectively.
- vi.) The number of generation zones using the criteria outlined in paragraph 14.15.35 has been determined as 21.
- vii.) The number of demand zones has been determined as 14, corresponding to the 14 GSP groups.

14.14.6 The underlying rationale behind Transmission Network Use of System charges is that efficient economic signals are provided to Users when services are priced to reflect the incremental costs of supplying them. Therefore, charges should reflect the impact that Users of the transmission system at different locations would have on the Transmission Owner's costs, if they were to increase or decrease their use of the respective systems. These costs are primarily defined as the investment costs in the transmission system, maintenance of the transmission system and maintaining a system capable of providing a secure bulk supply of energy.

The Transmission Licence requires The Company to operate the National Electricity Transmission System to specified standards. In addition The Company with other transmission licensees are required to plan and develop the National Electricity Transmission System to meet these standards. These requirements mean that the system must conform to a particular Security Standard and capital investment requirements are largely driven by the need to conform to both the deterministic and supporting cost benefit analysis aspects of this standard. It is this obligation, which provides the underlying rationale for the ICRP approach, i.e. for any changes in generation and demand on the system, The Company must ensure that it satisfies the requirements of the Security Standard.

14.14.7 The Security Standard identifies requirements on the capacity of component sections of the system given the expected generation and demand at each node, such that demand can be met and generators' output over the course of a year (capped at their Transmission Entry Capacity, TEC) can be accommodated in the most economic and efficient manner. The derivation of the incremental investment costs at different points on the system is therefore determined against the requirements of the system both at the time of peak demand and across the remainder of the year. The Security Standard uses a Demand Security Criterion and an Economy Criterion to assess capacity requirements. The charging methodology therefore recognises both these elements in its rationale.

14.14.8 The Demand Security Criterion requires sufficient transmission system capacity such that peak demand can be met through generation sources as defined in the Security Standard, whilst the Economy Criterion requires sufficient transmission system capacity to accommodate all types of generation in order to meet varying levels of demand efficiently. The latter is achieved through a set of deterministic parameters that have been derived from a generic Cost Benefit Analysis (CBA) seeking to identify an appropriate balance between constraint costs and the costs of transmission reinforcements.

**Formatted:** Indent: Left: 2.54 cm, Numbered + Level: 1 + Numbering Style: i, ii, iii, ... + Start at: 1 + Alignment: Left + Aligned at: 1.27 cm + Tab after: 2.54 cm + Indent at: 2.54 cm, Tabs: Not at 1.27 cm + 2.54 cm

**Formatted:** Indent: Left: 2.54 cm, Numbered + Level: 1 + Numbering Style: i, ii, iii, ... + Start at: 1 + Alignment: Left + Aligned at: 1.27 cm + Tab after: 2.54 cm + Indent at: 2.54 cm, Tabs: Not at 1.27 cm + 2.54 cm

**Formatted:** Indent: Left: 2.54 cm, Numbered + Level: 1 + Numbering Style: i, ii, iii, ... + Start at: 1 + Alignment: Left + Aligned at: 1.27 cm + Tab after: 2.54 cm + Indent at: 2.54 cm, Tabs: Not at 1.27 cm + 2.54 cm

**Formatted:** Indent: Left: 2.54 cm, Numbered + Level: 1 + Numbering Style: i, ii, iii, ... + Start at: 1 + Alignment: Left + Aligned at: 1.27 cm + Tab after: 2.54 cm + Indent at: 2.54 cm, Tabs: Not at 1.27 cm + 2.54 cm

**Deleted:** 26

**Formatted:** Indent: Left: 2.54 cm, Numbered + Level: 1 + Numbering Style: i, ii, iii, ... + Start at: 1 + Alignment: Left + Aligned at: 1.27 cm + Tab after: 2.54 cm + Indent at: 2.54 cm, Tabs: Not at 1.27 cm + 2.54 cm

**Formatted:** Numbered + Level: 1 + Numbering Style: 1, 2, 3, ... + Start at: 5 + Alignment: Left + Aligned at: 1.27 cm + Tab after: 1.27 cm + Indent at: 2.87 cm, Tabs: 1.9 cm, List tab + Not at 1.27 cm

**Formatted:** Numbered + Level: 1 + Numbering Style: 1, 2, 3, ... + Start at: 5 + Alignment: Left + Aligned at: 1.27 cm + Tab after: 1.27 cm + Indent at: 2.87 cm, Tabs: 1.9 cm, List tab + Not at 1.27 cm

**Deleted:** Capacities (TECs)

**Deleted:** .

**Deleted:** this peak element

**Formatted:** Indent: Left: 1.27 cm

**Deleted:** 14.14.8

**Formatted:** ... [1]

14.14.9 The TNUoS charging methodology seeks to reflect these arrangements through the use of dual backgrounds in the Transport Model, namely a Peak Security background representative of the Demand Security Criterion and a Year Round background representative of the Economy Criterion.

**Formatted:** Numbered + Level: 1 + Numbering Style: 1, 2, 3, ... + Start at: 5 + Alignment: Left + Aligned at: 1.27 cm + Tab after: 1.27 cm + Indent at: 2.87 cm, Tabs: 1.9 cm, List tab + Not at 1.27 cm

14.14.10 To recognise that various types of generation will have a different impact on incremental investment costs the charging methodology uses a generator's TEC, Peak Security flag, and Annual Load Factor (ALF) when determining Transmission Network Use of System charges relating to the Peak Security and Year Round backgrounds respectively.

**Formatted:** Numbered + Level: 1 + Numbering Style: 1, 2, 3, ... + Start at: 5 + Alignment: Left + Aligned at: 1.27 cm + Tab after: 1.27 cm + Indent at: 2.87 cm, Tabs: 1.9 cm, List tab + Not at 1.27 cm

14.14.11 In setting and reviewing these charges The Company has a number of further objectives. These are to:

- offer clarity of principles and transparency of the methodology;
- inform existing Users and potential new entrants with accurate and stable cost messages;
- charge on the basis of services provided and on the basis of incremental rather than average costs, and so promote the optimal use of and investment in the transmission system; and
- be implementable within practical cost parameters and time-scales.

**Formatted:** Numbered + Level: 1 + Numbering Style: 1, 2, 3, ... + Start at: 5 + Alignment: Left + Aligned at: 1.27 cm + Tab after: 1.27 cm + Indent at: 2.87 cm, Tabs: 1.9 cm, List tab + Not at 1.27 cm

14.14.9 Condition C13 of The Company's Transmission Licence governs the adjustment to Use of System charges for small generators. Under the condition, The Company is required to reduce TNUoS charges paid by eligible small generators by a designated sum, which will be determined by the Authority. The licence condition describes an adjustment to generator charges for eligible plant, and a consequential change to demand charges to recover any shortfall in revenue. The mechanism for recovery will ensure revenue neutrality over the lifetime of its operation although it does allow for effective under or over recovery within any year. For the avoidance of doubt, Condition C13 does not form part of the Use of System Charging Methodology.

**Formatted:** Indent: Left: 2.5 cm, Hanging: 1.29 cm, Bulleted + Level: 1 + Aligned at: 0 cm + Tab after: 0.63 cm + Indent at: 0.63 cm, Tabs: 3.89 cm, List tab + Not at 0.63 cm + 1.27 cm

**Formatted:** Numbered + Level: 1 + Numbering Style: 1, 2, 3, ... + Start at: 9 + Alignment: Left + Aligned at: 1.27 cm + Tab after: 1.27 cm + Indent at: 2.87 cm, Tabs: 1.9 cm, List tab + Not at 1.27 cm

14.14.10 The Company will typically calculate TNUoS tariffs annually, publishing final tariffs in respect of a Financial Year by the end of the preceding January. However The Company may update the tariffs part way through a Financial Year.

**Formatted:** Numbered + Level: 1 + Numbering Style: 1, 2, 3, ... + Start at: 9 + Alignment: Left + Aligned at: 1.27 cm + Tab after: 1.27 cm + Indent at: 2.87 cm, Tabs: 1.9 cm, List tab + Not at 1.27 cm

## 14.15 Derivation of the Transmission Network Use of System Tariff

**14.15.1** The Transmission Network Use of System (TNUoS) Tariff comprises two separate elements. Firstly, a locationally varying element derived from the DCLF ICRP transport model to reflect the costs of capital investment in, and the maintenance and operation of, a transmission system to provide bulk transport of power to and from different locations. Secondly, a non-locationally varying element related to the provision of residual revenue recovery. The combination of both these elements forms the TNUoS tariff.

**Formatted:** Numbered + Level: 1 + Numbering Style: 1, 2, 3, ... + Start at: 1 + Alignment: Left + Aligned at: 1.27 cm + Tab after: 1.27 cm + Indent at: 2.87 cm, Tabs: 1.9 cm, List tab + Not at 1.27 cm

**14.15.2** For generation TNUoS tariffs the locational element itself is comprised of four separate components. Two wider components -

- Peak Security, and
- Year Round

These components reflect the costs of the wider network under the different generation backgrounds set out in the Demand Security and Economy Criterion of the Security Standard respectively.

Two local components -

- Local substation, and
- Local circuit

These components reflect the costs of the local network.

Accordingly, the wider tariff represents the combined effect of the two wider locational tariff components and the residual element; and the local tariff represents the combination of the two local locational tariff components.

**Formatted:** Numbered + Level: 1 + Numbering Style: 1, 2, 3, ... + Start at: 1 + Alignment: Left + Aligned at: 1.27 cm + Tab after: 1.27 cm + Indent at: 2.87 cm, Tabs: 1.9 cm, List tab + Not at 1.27 cm

**Deleted:** three

**Deleted:** A

**Deleted:** component reflects

**Deleted:** , and

**Deleted:** combination of a

**Deleted:** a local

**Deleted:** component

**Deleted:**

**Formatted:** Indent: Left: 2.87 cm, No bullets or numbering, Tabs: Not at 1.27

**14.15.3** The process for calculating the TNUoS tariff is described below.

### The Transport Model

#### Model Inputs

**14.15.4** The DCLF ICRP transport model calculates the marginal costs of investment in the transmission system which would be required as a consequence of an increase in demand or generation at each connection point or node on the transmission system, based on a study of peak demand conditions using both a Peak Security and Year Round generation background on the transmission system. One measure of the investment costs is in terms of MWkm. This is the concept that ICRP uses to calculate marginal costs of investment. Hence, marginal costs are estimated initially in terms of increases or decreases in units of kilometres (km) of the transmission system for a 1 MW injection to the system.

**Formatted:** Numbered + Level: 1 + Numbering Style: 1, 2, 3, ... + Start at: 1 + Alignment: Left + Aligned at: 1.27 cm + Tab after: 1.27 cm + Indent at: 2.87 cm, Tabs: 1.9 cm, List tab + Not at 1.27 cm

**Formatted:** Numbered + Level: 1 + Numbering Style: 1, 2, 3, ... + Start at: 1 + Alignment: Left + Aligned at: 1.27 cm + Tab after: 1.27 cm + Indent at: 2.87 cm, Tabs: 1.9 cm, List tab + Not at 1.27 cm

**Formatted:** Numbered + Level: 1 + Numbering Style: 1, 2, 3, ... + Start at: 1 + Alignment: Left + Aligned at: 1.27 cm + Tab after: 1.27 cm + Indent at: 2.87 cm, Tabs: 1.9 cm, List tab + Not at 1.27 cm

**Deleted:** peak

**Formatted:** Indent: Left: 3 cm, Hanging: 1 cm, Bulleted + Level: 1 + Aligned at: 0 cm + Tab after: 0.63 cm + Indent at: 0.63 cm, Tabs: 4.02 cm, List tab + Not at 0.63 cm + 1.27 cm

**14.15.5** The transport model requires a set of inputs representative of the Demand Security and Economy Criterion set out in the Security Standards. These conditions on the transmission system are represented in the Peak Security and Year Round background respectively as follows:

- Nodal generation information per node (TEC, plant type and SQSS scaling factors)
- Nodal demand information

- Transmission circuits between these nodes
- The associated lengths of these routes, the proportion of which is overhead line or cable and the respective voltage level
- The cost ratio of each of 132kV overhead line, 132kV underground cable, 275kV overhead line, 275kV underground cable and 400kV underground cable to 400kV overhead line to give circuit expansion factors
- The cost ratio of each separate sub-sea AC circuit and HVDC circuit to 400kV overhead line to give circuit expansion factors
- 132kV overhead circuit capacity and single/double route construction information is used in the calculation of a generator's local charge.
- Offshore transmission cost and circuit/substation data

**Deleted:** costs

**14.15.6** For a given charging year "t", the nodal generation TEC figure and generation plant types at each node will be based on the Applicable Value for year "t" in the NETS Seven Year Statement in year "t-1" plus updates to the October of year "t-1". The contracted TECs and generation plant types in the NETS Seven Year Statement include all plant belonging to generators who have a Bilateral Agreement with the TOs. For example, for 2010/11 charges, the nodal generation data is based on the forecast for 2010/11 in the 2009 NETS Seven Year Statement plus any data included in the quarterly updates in October 2009.

**Deleted:** Identification of a reference node

**Formatted:** Numbered + Level: 1 + Numbering Style: 1, 2, 3, ... + Start at: 1 + Alignment: Left + Aligned at: 1.27 cm + Tab after: 1.27 cm + Indent at: 2.87 cm, Tabs: 1.9 cm, List tab + Not at 1.27 cm

**14.15.7** Scaling factors for different generation plant types are applied on their aggregated capacity for both Peak Security and Year Round backgrounds. The scaling is either Fixed or Variable (depending on the total demand level) in line with the factors used in the Security Standard, for example as shown in the table below.

<u>Generation Plant Type</u>	<u>Peak Security Background</u>	<u>Year Round Background</u>
<u>Intermittent</u>	<u>Fixed (0%)</u>	<u>Fixed (70%)</u>
<u>Nuclear &amp; CCS</u>	<u>Variable</u>	<u>Fixed (85%)</u>
<u>Interconnectors</u>	<u>Fixed (0%)</u>	<u>Fixed (100%)</u>
<u>Hydro</u>	<u>Variable</u>	<u>Variable</u>
<u>Pumped Storage</u>	<u>Variable</u>	<u>Fixed (50%)</u>
<u>Peaking</u>	<u>Variable</u>	<u>Fixed (0%)</u>
<u>Other (Conventional)</u>	<u>Variable</u>	<u>Variable</u>

**Formatted:** Numbered + Level: 1 + Numbering Style: 1, 2, 3, ... + Start at: 1 + Alignment: Left + Aligned at: 1.27 cm + Tab after: 1.27 cm + Indent at: 2.87 cm, Tabs: 1.9 cm, List tab + Not at 1.27 cm

**Formatted:** Indent: Left: 1.9 cm

**Formatted:** Numbered + Level: 1 + Numbering Style: 1, 2, 3, ... + Start at: 1 + Alignment: Left + Aligned at: 1.27 cm + Tab after: 1.27 cm + Indent at: 2.87 cm, Tabs: 1.9 cm, List tab + Not at 1.27 cm

These scaling factors and generation plant types are set out in the Security Standard. These may be reviewed from time to time. The latest version will be used in the calculation of TNUoS tariffs and is published in the Statement of Use of System Charges

**Deleted:** C

**Deleted:** .

**Formatted:** Indent: Left: 1.27 cm, No bullets or numbering, Tabs: Not at 1.27

**14.15.8** National Grid will categorise plant based on the categorisations described in the Security Standard. Peaking plant will include oil and OCGT technologies and Other (conventional) represents all remaining conventional plant not explicitly stated elsewhere in the table. In the event that a power station is made up of more than one technology type, the type of the higher Transmission Entry Capacity (TEC) would apply.

**Formatted:** Numbered + Level: 1 + Numbering Style: 1, 2, 3, ... + Start at: 1 + Alignment: Left + Aligned at: 1.27 cm + Tab after: 1.27 cm + Indent at: 2.87 cm, Tabs: 1.9 cm, List tab + Not at 1.27 cm

**14.15.9** Nodal demand data for the transport model will be based upon the GSP demand that Users have forecast to occur at the time of National Grid Peak Average Cold Spell (ACS) Demand for year "t" in the April Seven Year Statement for year "t-1" plus updates to the October of year "t-1".

**Formatted:** Indent: Left: 0.63 cm

**14.15.10** Transmission circuits for charging year "t" will be defined as those with existing wayleaves for the year "t" with the associated lengths based on the circuit lengths

**Formatted:** Numbered + Level: 1 + Numbering Style: 1, 2, 3, ... + Start at: 1 + Alignment: Left + Aligned at: 1.27 cm + Tab after: 1.27 cm + Indent at: 2.87 cm, Tabs: 1.9 cm, List tab + Not at 1.27 cm

indicated for year "t" in the April NETS Seven Year Statement for year "t-1" plus updates to October of year "t-1". If certain circuit information is not explicitly contained in the NETS Seven Year Statement, The Company will use the best information available.

14.15.11 The circuit lengths included in the transport model are solely those, which relate to assets defined as 'Use of System' assets.

14.15.12 For HVDC circuits, the impedance will be calculated to provide flows based on a ratio of the capacity provided by the HVDC link relative to the capacities on all major transmission system boundaries that it parallels.

14.15.13 The transport model employs the use of circuit expansion factors to reflect the difference in cost between (i) AC circuits and HVDC circuits, (ii) underground and sub-sea circuits, (iii) cabled circuits and overhead line circuits, (iv) 132kV and 275kV circuits, (v) 275kV circuits and 400kV circuits, and (vi), uses 400kV overhead line (i.e. the 400kV overhead line expansion factor is 1). As the transport model expresses cost as marginal km (irrespective of cables or overhead lines), some account needs to be made of the fact that investment in these other types of circuit (specifically HVDC and sub-sea cables of various voltages, 400kV underground cable, 275kV overhead line, 275kV underground cable, 132kV overhead line and 132kV underground cable) is more expensive than for 400kV overhead line. This is done by effectively 'expanding' these more expensive circuits by the relevant circuit expansion factor, thereby producing a larger marginal kilometre to reflect the additional cost of investing in these circuits compared to 400kV overhead line. When calculating the local circuit tariff for a generator, alternative 132kV and offshore expansion factors to those used in the remainder of the tariff calculation are applied to the generator's local circuits.

14.15.14 The circuit expansion factors for HVDC circuits and AC subsea cables are determined on a case by case basis using the costs which are specific to the individual projects containing HVDC or AC subsea circuits.

**Model Outputs**

14.15.15 The transport model takes the inputs described above and carries out the following steps individually for Peak Security and Year Round backgrounds.

14.15.16 Depending on the background, the TEC of the relevant generation plant types are scaled by a percentage as described in 14.15.7, above. The TEC of the remaining generation plant types in each background are uniformly scaled such that total national generation (scaled sum of contracted TECs) equals total national ACS Demand.

14.15.17 For each background, the model then uses a DCLF ICRP transport algorithm to derive the resultant pattern of flows based on the network impedance required to meet the nodal demand using the scaled nodal generation, assuming every circuit has infinite capacity. Flows on individual transmission circuits are compared for both backgrounds and the background giving rise to the highest flow is considered as the triggering criterion for future investment for that circuit for the purposes of the charging methodology. Therefore all circuits will be tagged as Peak Security or Year Round depending upon the background resulting in the highest flow. In the event that both backgrounds result in the same flow, the circuit will be tagged as Peak Security. Then it calculates the resultant total network Peak Security MWkm

**Formatted:** Indent: Left: 0.63 cm

**Formatted:** Indent: Left: 1.9 cm, Numbered + Level: 1 + Numbering Style: 1, 2, 3, ... + Start at: 1 + Alignment: Left + Aligned at: 1.27 cm + Tab after: 1.27 cm + Indent at: 2.87 cm, Tabs: 1.9 cm, List tab + Not at 1.27 cm

**Formatted:** Indent: Left: 0.63 cm

**Formatted:** Indent: Left: 1.9 cm, Numbered + Level: 1 + Numbering Style: 1, 2, 3, ... + Start at: 1 + Alignment: Left + Aligned at: 1.27 cm + Tab after: 1.27 cm + Indent at: 2.87 cm, Tabs: 1.9 cm, List tab + Not at 1.27 cm

**Deleted:**

**Formatted:** Indent: Left: 1.9 cm, Numbered + Level: 1 + Numbering Style: 1, 2, 3, ... + Start at: 1 + Alignment: Left + Aligned at: 1.27 cm + Tab after: 1.27 cm + Indent at: 2.87 cm, Tabs: 1.9 cm, List tab + Not at 1.27 cm

**Deleted:** routes

**Deleted:** routes, (ii)

**Deleted:** routes, (iii)

**Deleted:** routes

**Deleted:** routes

**Deleted:** iv

**Formatted:** Indent: Left: 1.9 cm

**Deleted:** A reference node is required as a

**Formatted** ... [2]

**Deleted:** point for

**Deleted:** calculation of marginal

**Deleted:** . It determines the magnitude of the marginal ... [3]

**Deleted:** North of Scotland, all nodal generation marginal ... [4]

**Formatted:** Indent: Left: 0 cm

**Formatted:** Indent: Left: 1.89 cm

**Formatted:** Indent: Left: 0.63 cm

**Formatted** ... [5]

**Deleted:** firstly scales

**Deleted:** nodal

**Formatted** ... [6]

**Deleted:** capacity

**Deleted:** The

**Formatted** ... [7]

and Year Round MWkm, using the relevant circuit expansion factors as appropriate.

14.15.18 Using these baseline networks for Peak Security and Year Round backgrounds, the model then calculates for a given injection of 1MW of generation at each node, with a corresponding 1MW offtake (demand) distributed across all demand nodes in the network, the increase or decrease in total MWkm of the whole Peak Security and Year Round networks. The proportion of the 1MW offtake allocated to any given demand node will be based on total background nodal demand in the model. For example, with a total GB demand of 60GW in the model, a node with a demand of 600MW would contain 1% of the offtake: i.e. 0.01MW.

14.15.19 Given the assumption of a 1MW injection, for simplicity the marginal costs are expressed solely in km. This gives a Peak Security marginal km cost and a Year Round marginal km cost for generation at each node (although not that used to calculate generation tariffs which considers local and wider cost components). The Peak Security and Year Round marginal km costs for demand at each node are equal and opposite to the Peak Security and Year Round nodal marginal km respectively for generation and these are used to calculate demand tariffs. Note the marginal km costs can be positive or negative depending on the impact the injection of 1MW of generation has on the total circuit km.

14.15.20 Using a similar methodology, the local and wider marginal km costs used to determine generation TNUoS tariffs are calculated by injecting 1MW of generation against the node(s) the generator is modelled at and increasing by 1MW the offtake across the distributed reference node. It should be noted that although the wider marginal km costs are calculated for both Peak Security and Year Round backgrounds, the local marginal km costs are calculated on the Year Round background.

14.15.21 In addition, any circuits in the model, identified as local assets to a node will have the local circuit expansion factors which are applied in calculating that particular node's marginal km. Any remaining circuits will have the TO specific wider circuit expansion factors applied.

14.15.22 An example is contained in 14.21 Transport Model Example.

### Calculation of local nodal marginal km

14.15.23 In order to ensure assets local to generation are charged in a cost reflective manner, a generation local circuit tariff is calculated. The nodal specific charge provides a financial signal reflecting the security and construction of the infrastructure circuits that connect the node to the transmission system.

14.15.24 Generators directly connected to a MITS node will have a zero local circuit tariff.

14.15.25 Generators not connected to a MITS node will have a local circuit tariff derived from the local nodal marginal km for the generation node i.e. the increase or decrease in marginal km along the transmission circuits connecting it to all adjacent MITS nodes (local assets).

14.15.26 Main Interconnected Transmission System (MITS) nodes are defined from a charging perspective only as:

- Grid Supply Point connections with 2 or more transmission circuits connecting at the site; or
- connections with more than 4 transmission circuits connecting at the site.

Formatted: Indent: Left: 0.63 cm

Deleted: this

Formatted: Indent: Left: 1.9 cm, Numbered + Level: 1 + Numbering Style: 1, 2, 3, ... + Start at: 1 + Alignment: Left + Aligned at: 1.27 cm + Tab after: 1.27 cm + Indent at: 2.87 cm, Tabs: 1.9 cm, List tab + Not at 1.27 cm

Deleted: at the reference node.

Deleted: network.

Formatted: Indent: Left: 1.9 cm, Numbered + Level: 1 + Numbering Style: 1, 2, 3, ... + Start at: 1 + Alignment: Left + Aligned at: 1.27 cm + Tab after: 1.27 cm + Indent at: 2.87 cm, Tabs: 1.9 cm, List tab + Not at 1.27 cm

Deleted: cost

Deleted: node

Deleted: this

Deleted: this is

Formatted: Indent: Left: 0.63 cm

Formatted: Indent: Left: 1.9 cm, Numbered + Level: 1 + Numbering Style: 1, 2, 3, ... + Start at: 1 + Alignment: Left + Aligned at: 1.27 cm + Tab after: 1.27 cm + Indent at: 2.87 cm, Tabs: 1.9 cm, List tab + Not at 1.27 cm

Deleted: at

Deleted:

Deleted: this model,

Formatted ... [8]

Formatted: Indent: Left: 0.63 cm

Formatted ... [9]

Formatted: Indent: Left: 0.63 cm

Formatted ... [10]

Formatted: Justified, Indent: Left: 1.9 cm

Deleted: <#>Main Interconnected Transmissi... [11]

Formatted ... [12]

Formatted: Indent: Left: 0.63 cm

Formatted ... [13]

Formatted: Indent: Left: 0.63 cm

Formatted ... [14]

Formatted ... [15]

Other than where the export from a **Power Station** to the main **National Electricity Transmission System** is dependent on a single transmission circuit. Illustrative diagrams are provided in 14.24 to show examples of such cases.

14.15.27 Where a Grid Supply Point is defined as a point of supply from the **National Electricity Transmission System** to network operators or non-embedded customers excluding generator or interconnector load alone. For the avoidance of doubt, generator or interconnector load would be subject to the circuit component of its Local Charge.

**Formatted:** Font: Arial (W1), 11 pt

**Formatted:** Font: Arial (W1), 11 pt, Bold

**Formatted:** Bullets and Numbering

14.15.28 A transmission circuit is part of the **National Electricity Transmission System** between two or more circuit-breakers which includes transformers, cables and overhead lines but excludes busbars and generation circuits

**Formatted:** Font: Arial (W1), 11 pt, Bold

**Formatted:** Bullets and Numbering

14.15.29 The main **National Electricity Transmission System** is that part of the **National Electricity Transmission System** supplying the majority of GB demand.

**Formatted:** Font: Arial (W1), 11 pt, Bold

**Formatted:** Font: Arial (W1), 11 pt, Bold

**Formatted:** Bullets and Numbering

**Calculation of zonal marginal km**

14.15.30 Given the requirement for relatively stable cost messages through the ICRP methodology and administrative simplicity, nodes are assigned to zones. Typically, generation zones will be reviewed at the beginning of each price control period with another review only undertaken in exceptional circumstances. Any rezoning required during a price control period will be undertaken with the intention of minimal disruption to the established zonal boundaries. The full criteria for determining generation zones are outlined in paragraph 14.15.35. The number of generation zones set for 2010/11 is 20.

**Deleted:** Illustrative diagrams are provided in 14.24.

**Formatted:** Bullets and Numbering

**Deleted:** 26

14.15.31 Demand zone boundaries have been fixed and relate to the GSP Groups used for energy market settlement purposes.

**Formatted:** Bullets and Numbering

14.15.32 The nodal marginal km are amalgamated into zones by weighting them by their relevant generation or demand capacity.

**Formatted:** Bullets and Numbering

14.15.33 Generators will have zonal tariffs derived from both the wider **Peak Security nodal marginal km**; and the wider **Year Round** nodal marginal km for the generation node, calculated as the increase or decrease in marginal km along all transmission circuits except those classified as local assets.

**Formatted:** Bullets and Numbering

**Deleted:** a

**Deleted:** tariff

The zonal **Peak Security** marginal km for generation is calculated as:

**Formatted:** Indent: Left: 1.27 cm, No bullets or numbering, Tabs: Not at 1.27

$$WNMkm_{j PS} = \frac{NMkm_{j PS} * Gen_j}{\sum_{j \in Gi} Gen_j}$$

**Deleted:**  $WNMkm_j = \frac{NMkm_j}{Gen_j}$

$$ZMkm_{Gi PS} = \sum_{j \in Gi} WNMkm_{j PS}$$

**Deleted:** ¶

**Deleted:**  $ZMkm_{Gi} = \sum_{j \in Gi} WNMkm_{j PS}$

Where

Gi = Generation zone

j = Node

NMkm<sub>ps</sub> = **Peak Security** Wider nodal marginal km from transport model

**Deleted:** . . = .

WNMkm<sub>ps</sub> = **Peak Security** Weighted nodal marginal km

**Deleted:** . = .



$ZMkm_{PS}$  = Peak Security Zonal Marginal km  
 $Gen$  = Nodal Generation (scaled by the appropriate Peak Security Scaling factor) from the transport model

Deleted: . . .  
 Deleted: . . .  
 Formatted: Indent: Left: 1.27 cm, Hanging: 3.81 cm  
 Deleted: The  
 Deleted: demand zones are  
 Deleted: follows:  
 Deleted:  $WNMkm_j = \frac{-1 * NMkm_j * Dem_j}{\sum_{j \in Di} Dem_j}$   
 Formatted: Justified  
 Formatted: Font: Arial (W1), 11 pt  
 Deleted:  $ZMkm_{Di} = \sum_{j \in Di} WNMkm_{jPS}$   
 Formatted: Justified  
 Formatted: Indent: Left: 1.27 cm, First line: 0 cm

Similarly, the zonal Year Round marginal km for generation is calculated as:

$$WNMkm_{jYR} = \frac{NMkm_{jYR} * Gen_j}{\sum_{j \in Gi} Gen_j}$$

$$ZMkm_{GiYR} = \sum_{j \in Gi} WNMkm_{jYR}$$

Where  
 $NMkm_{YR}$  = Year Round Wider nodal marginal km from transport model  
 $WNMkm_{YR}$  = Year Round Weighted nodal marginal km  
 $ZMkm_{YR}$  = Year Round Zonal Marginal km  
 $Gen$  = Nodal Generation (scaled by the appropriate Year Round Scaling factor) from the transport model

14.15.34 The zonal Peak Security marginal km for demand zones are calculated as follows:

$$WNMkm_{jPS} = \frac{-1 * NMkm_{jPS} * Dem_j}{\sum_{j \in Di} Dem_j}$$

$$ZMkm_{DiPS} = \sum_{j \in Di} WNMkm_{jPS}$$

Where:  
 $Di$  = Demand zone  
 $Dem$  = Nodal Demand from transport model

Similarly, the zonal Year Round marginal km for demand zones are calculated as follows:

$$WNMkm_{jYR} = \frac{-1 * NMkm_{jYR} * Dem_j}{\sum_{j \in Di} Dem_j}$$

$$ZMkm_{DiYR} = \sum_{j \in Di} WNMkm_{jYR}$$

14.15.35 A number of criteria are used to determine the definition of the generation zones. Whilst it is the intention of The Company that zones are fixed for the duration of a price control period, it may become necessary in exceptional circumstances to review

Formatted: Bullets and Numbering  
 Formatted: Indent: Left: 1.6 cm  
 Formatted: Bullets and Numbering

the boundaries having been set. In both circumstances, the following criteria are used to determine the zonal boundaries:

- i.) Zoning is determined using the generation background with the most MWkm of circuits. Zones should contain relevant nodes whose total wider marginal costs from the relevant generation background (as determined from the output from the transport model, the relevant expansion constant and the locational security factor, see below) are all within +/-£1.00/kW (nominal prices) across the zone. This means a maximum spread of £2.00/kW in nominal prices across the zone.
- ii.) The nodes within zones should be geographically and electrically proximate.
- iii.) Relevant nodes are considered to be those with generation connected to them as these are the only ones, which contribute to the calculation of the zonal generation tariff.

**14.15.36** The process behind the criteria in 14.15.35 is driven by initially applying the nodal marginal costs from the relevant generation background within the DCLF Transport model onto the appropriate areas of a substation line diagram. Generation nodes are grouped into initial zones using the +/- £1.00/kW range. All nodes within each zone are then checked to ensure the geographically and electrically proximate criteria have been met using the substation line diagram. The established zones are inspected to ensure the least number of zones are used with minimal change from previously established zonal boundaries. The zonal boundaries are finally confirmed using the demand nodal costs from the relevant generation background for guidance.

**14.15.37** The zoning criteria are applied to a reasonable range of DCLF ICRP transport model scenarios, the inputs to which are determined by The Company to create appropriate TNUoS generation zones. The minimum number of zones, which meet the stated criteria, are used. If there is more than one feasible zonal definition of a certain number of zones, The Company determines and uses the one that best reflects the physical system boundaries.

**14.15.38** Zones will typically not be reviewed more frequently than once every price control period to provide some stability. However, in exceptional circumstances, it may be necessary to review zoning more frequently to maintain appropriate, cost reflective, locational cost signals. For example, if a new generator connecting to the transmission system would cause the creation of a new generation zone for that generator alone, it may not be appropriate from a cost reflective perspective to wait until the next price control period to undertake this rezoning. If any such rezoning is required, it will be undertaken against a background of minimal change to existing generation zones and in line with the notification process set out in the Transmission Licence and CUSC.

**Formatted:** Indent: Left: 2.87 cm, Numbered + Level: 1 + Numbering Style: i, ii, iii, ... + Start at: 1 + Alignment: Left + Aligned at: 0 cm + Tab after: 1.27 cm + Indent at: 0 cm, Tabs: 7.31 cm, List tab + Not at 1.27 cm

**Formatted:** Indent: Left: 2.75 cm

**Formatted:** Indent: Left: 2.87 cm, Numbered + Level: 1 + Numbering Style: i, ii, iii, ... + Start at: 1 + Alignment: Left + Aligned at: 0 cm + Tab after: 1.27 cm + Indent at: 0 cm, Tabs: 7.31 cm, List tab + Not at 1.27 cm

**Formatted:** Indent: Left: 2.75 cm

**Formatted:** Indent: Left: 2.87 cm, Numbered + Level: 1 + Numbering Style: i, ii, iii, ... + Start at: 1 + Alignment: Left + Aligned at: 0 cm + Tab after: 1.27 cm + Indent at: 0 cm, Tabs: 7.31 cm, List tab + Not at 1.27 cm

**Formatted:** Bullets and Numbering

**Deleted:** 26

**Formatted:** Bullets and Numbering

**Formatted:** Bullets and Numbering

### Deriving the Final Local £/kW Tariff and the Wider £/kW Tariff

**14.15.39** The zonal marginal km (ZMkm<sub>Gi</sub>) are converted into costs and hence a tariff by multiplying by the **Expansion Constant** and the **Locational Security Factor** (see below). The nodal local marginal km (NLMkm<sup>L</sup>) are converted into costs and hence a tariff by multiplying by the **Expansion Constant** and a **Local Security Factor**.

**Formatted:** Bullets and Numbering

### The Expansion Constant

**14.15.40** The expansion constant, expressed in £/MWkm, represents the annuitised value of the transmission infrastructure capital investment required to transport 1 MW over 1 km.

**Formatted:** Bullets and Numbering

Its magnitude is derived from the projected cost of 400kV overhead line, including an estimate of the cost of capital, to provide for future system expansion.

**14.15.41** In the methodology, the expansion constant is used to convert the marginal km figure derived from the transport model into a £/MW signal. The tariff model performs this calculation, in accordance with 14.15.71 – 14.15.93 and also then calculates the residual element of the overall tariff (to ensure correct revenue recovery in accordance with the price control), in accordance with 14.15.108.

Formatted: Bullets and Numbering  
Deleted: 60...65...81. ... [16]

**14.15.42** The transmission infrastructure capital costs used in the calculation of the expansion constant are provided via an externally audited process. They also include information provided from all onshore Transmission Owners (TOs). They are based on historic costs and tender valuations adjusted by a number of indices (e.g. global price of steel, labour, inflation, etc.). The objective of these adjustments is to make the costs reflect current prices, making the tariffs as forward looking as possible. This cost data represents The Company's best view; however it is considered as commercially sensitive and is therefore treated as confidential. The calculation of the expansion constant also relies on a significant amount of transmission asset information, much of which is provided in the Seven Year Statement.

Formatted: Bullets and Numbering

**14.15.43** For each circuit type and voltage used onshore, an individual calculation is carried out to establish a £/MWkm figure, normalised against the 400KV overhead line (OHL) figure, these provide the basis of the onshore circuit expansion factors discussed in 14.15.51 – 14.15.57. In order to simplify the calculation a unity power factor is assumed, converting £/MVAkm to £/MWkm. This reflects that the fact tariffs and charges are based on real power.

Formatted: Bullets and Numbering  
Deleted: 42...47. ... [17]

**14.15.44** The table below shows the first stage in calculating the onshore expansion constant. A range of overhead line types is used and the types are weighted by recent usage on the transmission system. This is a simplified calculation for 400kV OHL using example data:

Formatted: Bullets and Numbering

400kV OHL expansion constant calculation					
MW	Type	£(000)/km	Circuit km*	£/MWkm	Weight
A	B	C	D	E = C/A	F = E*D
6500	La	700	500	107.69	53846
6500	Lb	780	0	120.00	0
3500	La/b	600	200	171.43	34286
3600	Lc	400	300	111.11	33333
4000	Lc/a	450	1100	112.50	123750
5000	Ld	500	300	100.00	30000
5400	Ld/a	550	100	101.85	10185
Sum			2500 (G)	285400 (H)	
				Weighted Average (J= H/G):	114.160 (J)

Formatted  
Formatted ... [18]  
Formatted ... [19]  
Formatted ... [20]  
Formatted ... [21]  
Formatted ... [22]  
Formatted ... [23]  
Formatted ... [24]  
Formatted ... [25]  
Formatted ... [26]  
Formatted  
Formatted: Font: 11 pt  
Formatted  
Formatted: Font: 11 pt  
Formatted  
Formatted: Font: 11 pt  
Formatted  
Formatted: Font: 11 pt  
Formatted  
Formatted: Font: 11 pt  
Formatted  
Formatted: Font: 11 pt  
Formatted  
Formatted: Font: 11 pt  
Formatted  
Formatted: Font: 11 pt

\*These are circuit km of types that have been provided in the previous 10 years. If no information is available for a particular category the best forecast will be used.

**14.15.45** The weighted average £/MWkm (J in the example above) is then converted in to an annual figure by multiplying it by an annuity factor. The formula used to calculate of the annuity factor is shown below:

**Formatted:** Bullets and Numbering

$$Annuityfactor = \frac{1}{\left[ \frac{1 - (1 + WACC)^{-AssetLife}}{WACC} \right]}$$

**14.15.46** The Weighted Average Cost of Capital (WACC) and asset life are established at the start of a price control and remain constant throughout a price control period. The WACC used in the calculation of the annuity factor is the The Company regulated rate of return, this assumes that it will be reasonably representative of all licensees. The asset life used in the calculation is 50 years; the appropriateness of this is reviewed when the annuity factor is recalculated at the start of a price control period. These assumptions provide a current annuity factor of 0.066.

**Formatted:** Bullets and Numbering

**14.15.47** The final step in calculating the expansion constant is to add a share of the annual transmission overheads (maintenance, rates etc). This is done by multiplying the average weighted cost (J) by an ‘overhead factor’. The ‘overhead factor’ represents the total business overhead in any year divided by the total Gross Asset Value (GAV) of the transmission system. This is recalculated at the start of each price control period. The overhead factor used in the calculation of the expansion constant for 2009/10 is 1.8%. The overhead and annuitised costs are then added to give the expansion constant.

**Formatted:** Bullets and Numbering

**14.15.48** Using the previous example, the final steps in establishing the expansion constant are demonstrated below:

**Formatted:** Bullets and Numbering

400kV OHL expansion constant calculation	Ave £/MWkm
OHL	114.160
Annuitised	7.535
Overhead	2.055
<b>Final</b>	<b>9.589</b>

**14.15.49** This process is carried out for each voltage onshore, along with other adjustments to take account of upgrade options, see 14.15.54, and normalised against the 400KV overhead line cost (the expansion constant) the resulting ratios provide the basis of the onshore expansion factors. The process used to derive circuit expansion factors for Offshore Transmission Owner networks is described in 14.15.60.

**Formatted:** Bullets and Numbering

**Deleted:** 45

**Deleted:** 5

**14.15.50** This process of calculating the incremental cost of capacity for a 400kV OHL, along with calculating the onshore expansion factors is carried out for the first year of the price control and is increased by inflation, RPI, (May–October average increase, as defined in The Company’s Transmission Licence) each subsequent year of the price control period. The expansion constant for 2010/11 is 10.633.

**Formatted:** Bullets and Numbering

**Onshore Wider Circuit Expansion Factors**

**14.15.51** Base onshore expansion factors are calculated by deriving individual expansion constants for the various types of circuit, following the same principles used to calculate the 400kV overhead line expansion constant. The factors are then derived by dividing the calculated expansion constant by the 400kV overhead line expansion constant. The factors will be fixed for each respective price control period.

**Formatted:** Bullets and Numbering

**14.15.52** In calculating the onshore underground cable factors, the forecast costs are weighted equally between urban and rural installation, and direct burial has been assumed. The operating costs for cable are aligned with those for overhead line. An allowance for overhead costs has also been included in the calculations. **Formatted: Bullets and Numbering**

**14.15.53** The 132kV onshore circuit expansion factor is applied on a TO basis. This is to reflect the regional variation of plans to rebuild circuits at a lower voltage capacity to 400kV. The 132kV cable and line factor is calculated on the proportion of 132kV circuits likely to be uprated to 400kV. The 132kV expansion factor is then calculated by weighting the 132kV cable and overhead line costs with the relevant 400kV expansion factor, based on the proportion of 132kV circuitry to be uprated to 400kV. For example, in the TO areas of National Grid and Scottish Power where there are no plans to uprate any 132kV circuits, the full cable and overhead line costs of 132kV circuit are reflected in the 132kV expansion factor calculation. **Formatted: Bullets and Numbering**

**14.15.54** The 275kV onshore circuit expansion factor is applied on a GB basis and includes a weighting of 83% of the relevant 400kV cable and overhead line factor. This is to reflect the averaged proportion of circuits across all three Transmission Licensees which are likely to be uprated from 275kV to 400kV across GB within a price control period. **Formatted: Bullets and Numbering**

**14.15.55** The 400kV onshore circuit expansion factor is applied on a GB basis and reflects the full costs for 400kV cable and overhead lines. **Formatted: Bullets and Numbering**

**14.15.56** AC sub-sea cable and HVDC circuit expansion factors are calculated on a case by case basis using actual project costs (Specific Circuit Expansion Factors). **Formatted: Bullets and Numbering**

**14.15.57** For HVDC circuit expansion factors both the full cost of the converter stations and the full cost of the cable are included in the calculation. **Formatted: Bullets and Numbering**

The TO specific onshore circuit expansion factors calculated for 2008/9 (and rounded to 2 decimal places) are: **Formatted: Bullets and Numbering**

#### Scottish Hydro Region

400kV <u>underground</u> cable factor:	22.39
275kV <u>underground</u> cable factor:	22.39
132kV <u>underground</u> cable factor:	27.79
400kV line factor:	1.00
275kV line factor:	1.14
132kV line factor:	2.24

#### Scottish Power & National Grid Regions

400kV <u>underground</u> cable factor:	22.39
275kV <u>underground</u> cable factor:	22.39
132kV <u>underground</u> cable factor:	30.22
400kV line factor:	1.00
275kV line factor:	1.14
132kV line factor:	2.80

#### **Onshore Local Circuit Expansion Factors**

**14.15.58** The local onshore circuit tariff is calculated using local onshore circuit expansion factors. These expansion factors are calculated using the same methodology as the

onshore wider expansion factor but without taking into account the proportion of circuit kms that are planned to be updated.

14.15.59 In addition, the 132kV onshore overhead line circuit expansion factor is sub divided into four more specific expansion factors. This is based upon maximum (winter) circuit continuous rating (MVA) and route construction whether double or single circuit.

400kV <u>underground</u> cable factor:	22.39
275kV <u>underground</u> cable factor:	22.39
132kV <u>underground</u> cable factor:	30.22
400kV line factor:	1.00
275kV line factor:	1.14
132kV line factor (single; <200MVA):	10.00
132kV line factor (double; <200MVA):	8.32
132kV line factor (single; >=200MVA):	7.13
132kV line factor (double; >=200MVA):	4.42

**Offshore Circuit Expansion Factors**

14.15.60 Offshore expansion factors (£/MWkm) are derived from information provided by Offshore Transmission Owners for each offshore circuit. Offshore expansion factors are Offshore Transmission Owner and circuit specific. Each Offshore Transmission Owner will periodically provide, via the STC, information to derive an annual circuit revenue requirement. The offshore circuit revenue shall include revenues associated with the Offshore Transmission Owner’s reactive compensation equipment, harmonic filtering equipment, asset spares and HVDC converter stations.

14.15.61 In the first year of connection, the offshore circuit expansion factor would be calculated as follows:

$$\frac{CRevOFTO1}{L \times CircRat} \div \text{Onshore 400kV OHL Expansion Constant}$$

Where:

- CRevOFTO1 = The offshore circuit revenue in £ for Year 1
- L = The total circuit length in km of the offshore circuit
- CircRat = The continuous rating of the offshore circuit

14.15.62 In all subsequent years, the offshore circuit expansion factor would be calculated as follows:

$$\frac{AvCRevOFTO}{L \times CircRat} \div \text{Onshore 400kV OHL Expansion Constant}$$

Where:

- AvCRevOFTO = The annual offshore circuit revenue averaged over the remaining years of the onshore National Electricity Transmission System Operator (NETSO) price control
- L = The total circuit length in km of the offshore circuit
- CircRat = The continuous rating of the offshore circuit

14.15.63 Prevailing OFFSHORE TRANSMISSION OWNER specific expansion factors will be published in this statement. These shall be re-calculated at the start of each price control when the onshore expansion constants are revisited.

## The Locational Onshore Security Factor

- 14.15.64 The locational onshore security factor is derived by running a secure DCLF ICRP transport study based on the same market background as used for Zoning in the DCLF ICRP transport model. This calculates the nodal marginal costs where peak demand can be met despite the Security and Quality of Supply Standard contingencies (simulating single and double circuit faults) on the network. Essentially the calculation of secured nodal marginal costs is identical to the process outlined above except that the secure DCLF study additionally calculates a nodal marginal cost taking into account the requirement to be secure against a set of worse case contingencies in terms of maximum flow for each circuit.
- 14.15.65 The secured nodal cost differential is compared to that produced by the DCLF ICRP transport model and the resultant ratio of the two determines the locational security factor using the Least Squares Fit method. Further information may be obtained from the charging website<sup>1</sup>.
- 14.15.66 The locational onshore security factor derived for 2010/11 is 1.8 and is based on an average from a number of studies conducted by The Company to account for future network developments. The security factor is reviewed for each price control period and fixed for the duration.

### Local Security Factors

- 14.15.67 Local onshore security factors are generator specific and are applied to a generators local onshore circuits. If the loss of any one of the local circuits prevents the export of power from the generator to the MITS then a local security factor of 1.0 is applied. For generation with circuit redundancy, a local security factor is applied that is equal to the locational security factor, currently 1.8.
- 14.15.68 Where a Transmission Owner has designed a local onshore circuit (or otherwise that circuit once built) to a capacity lower than the aggregated TEC of the generation using that circuit, then the local security factor of 1.0 will be multiplied by a Counter Correlation Factor (CCF) as described in the formula below:

$$CCF = \frac{D_{\min} + T_{cap}}{G_{cap}}$$

Where:  $D_{\min}$  = minimum annual net demand (MW) supplied via that circuit in the absence of that generation using the circuit

$T_{cap}$  = transmission capacity built (MVA)

$G_{cap}$  = aggregated TEC of generation using that circuit

CCF cannot be greater than 1.0.

- 14.15.69 A specific offshore local security factor (LocalSF) will be calculated for each offshore connection using the following methodology:

Deleted: CCF can not be greater than 1.0.¶

<sup>1</sup> <http://www.nationalgrid.com/uk/Electricity/Charges/>

$$LocalSF = \frac{NetworkExportCapacity}{\sum_k Gen_k}$$

Where:

NetworkExportCapacity = the total export capacity of the network  
 k = the generation connected to the offshore network

14.15.70 The offshore security factor for single circuits with a single cable will be 1.0 and for multiple circuit connections will be capped at the locational onshore security factor, derived as 1.8 for 2010/11.

Formatted: Indent: Left: 1.27 cm

### Initial Transport Tariff

14.15.71 First an Initial Transport Tariff (ITT) must be calculated for both Peak Security and Year Round backgrounds. For Generation, the Peak Security zonal marginal km (ZMkm<sub>PS</sub>) and Year Round zonal marginal km (ZMkm<sub>YR</sub>) are simply multiplied by the expansion constant and the locational security factor to give the Peak Security ITT and Year Round ITT respectively:

Deleted: initial transport tariff

$$ZMkm_{GiPS} \times EC \times LSF = ITT_{GiPS}$$

Deleted:  $ZMkm_{Gi} \times EC \times I$

$$ZMkm_{GiYR} \times EC \times LSF = ITT_{GiYR}$$

Where

ZMkm<sub>GiPS</sub> = Peak Security Zonal Marginal km for each generation zone

Deleted: . = .

ZMkm<sub>GiYR</sub> = Year Round Zonal Marginal km for each generation zone

EC = Expansion Constant

LSF = Locational Security Factor

ITT<sub>GiPS</sub> = Peak Security Initial Transport Tariff (£/MW) for each generation zone

Deleted: . ITT<sub>Gi</sub> . = .

ITT<sub>GiYR</sub> = Year Round Initial Transport Tariff (£/MW) for each generation zone

Formatted: Indent: Left: 1.27 cm, Tabs: Not at 2 cm + 2.5 cm + 3 cm

14.15.72 Similarly, for demand the Peak Security zonal marginal km (ZMkm<sub>PS</sub>) and Year Round zonal marginal km (ZMkm<sub>YR</sub>) are simply multiplied by the expansion constant and the locational security factor to give the Peak Security ITT and Year Round ITT respectively:

Deleted: initial transport tariff

$$ZMkm_{DiPS} \times EC \times LSF = ITT_{DiPS}$$

Deleted:  $ZMkm_{Di} \times EC \times I$

$$ZMkm_{DiYR} \times EC \times LSF = ITT_{DiYR}$$

Where

ZMkm<sub>DiPS</sub> = Peak Security Zonal Marginal km for each demand zone

Deleted: . = .

ZMkm<sub>DiYR</sub> = Year Round Zonal Marginal km for each demand zone

Deleted: EC . . = . Expansion Constant

ITT<sub>DiPS</sub> = Peak Security Initial Transport Tariff (£/MW) for each demand zone

Deleted: LSF . . = . Locational Security Factor

ITT<sub>DiYR</sub> = Year Round Initial Transport Tariff (£/MW) for each demand zone

Formatted: Indent: Left: 1.27 cm, First line: 0 cm

Deleted: . ITT<sub>Di</sub> . = .

Formatted: Indent: Left: 1.27 cm



14.15.73 The next step is to multiply these ITTs by the expected metered triad demand and generation capacity to gain an estimate of the initial revenue recovery, for both Peak Security and Year Round backgrounds. The metered triad demand and generation capacity are based on forecasts provided by Users and are confidential.

**Deleted:** initial transport tariffs  
**Deleted:** . Both of these latter parameters

14.15.74 In addition, the initial tariffs for generation are also multiplied by the Peak Security flag when calculating the initial revenue recovery component for the Peak Security background. Similarly, when calculating the initial revenue recovery component for the Year Round background, the initial tariffs are multiplied by the Annual Load Factor (see below).

**Formatted:** Font: Arial (W1), 11 pt  
**Formatted:** Indent: Left: 1.27 cm

**Deleted:** .

$$\sum_{Gi=1}^{21} (ITT_{Gi} \times G_{Gi}) = ITRR_G$$

and

$$\sum_{Di=1}^{14} (ITT_{Di} \times D_{Di}) = ITRR_I$$

**Peak Security (PS) Flag**

14.15.75 The revenue from a specific generator due to the Peak Security locational tariff needs to be multiplied by the appropriate Peak Security (PS) flag. The PS flags indicate the extent to which a generation plant type contributes to the need for transmission network investment at peak demand conditions. The PS flag is derived from the contribution of differing generation sources to the demand security criterion as described in the Security Standard. In the event of a significant change to the demand security assumptions in the Security Standard, National Grid will review the use of the PS flag.

**Formatted:** Font: Arial (W1), 11 pt  
**Deleted:** ¶  
**Deleted:** -----Page Break-----  
 ¶  
 ¶  
**Formatted:** Bullets and Numbering

Generation Plant Type	PS flag
Intermittent	0
Other	1

**Annual Load Factor (ALF)**

14.15.76 The ALF for each individual Power Station is calculated using the relevant TEC (MW) and corresponding output data. Where output data is not available for a Power Station, including for new Power Stations and emerging Power Station technologies, generic data for the appropriate generation plant type will be used.

**Formatted:** Numbered + Level: 1 + Numbering Style: 1, 2, 3, ... + Start at: 1 + Alignment: Left + Aligned at: 1.27 cm + Tab after: 1.27 cm + Indent at: 2.87 cm

14.15.77 For a given charging year “t” the Power Station ALF will be based on information from the previous five charging years, calculated for each charging year as set out below.

**Deleted:** The ALF for each individual Power Station is calculated using the relevant TEC and corresponding output data. Where output data is not available for a power station, including for new and emerging technologies, generic data for the appropriate generation plant type will be used.¶  
**Formatted:** Font: Arial (W1)  
**Formatted:** Font: Arial (W1)

$$ALF = \frac{\sum_{p=1}^{17520} GMWh_p}{\sum_{p=1}^{17520} TEC_p \times 0.5}$$

Where:  
 GMWh<sub>p</sub> is the maximum of FPN or actual metered output in a Settlement Period related to the power station TEC (MW); and  
 TEC<sub>p</sub> is the TEC (MW) applicable to that Power Station for that Settlement Period including any STTEC and LDTEC, accounting for any trading of TEC.

**Deleted:** . ITRR<sub>G</sub> . . = .  
**Formatted:** Bullets and Numbering

14.15.78 The appropriate output (FPN or actual metered) figure is derived from BM Unit data available to National Grid and relates to the total TEC of the Power Station.

**Deleted:** .  
**Formatted:** Bullets and Numbering

14.15.79 Once all five charging year ALFs have been calculated for the individual Power Station they are compared, and the highest and lowest figures are discarded. The final ALF, to

**Deleted:** balancing mechanism user  
**Formatted:** Font: Arial (W1), 11 pt, Bold  
**Formatted:** Bullets and Numbering

be used for transmission charging purposes, is calculated as the average of the remaining three ALFs.

14.15.80 In the event that only four charging years of complete output (FPN or actual metered) data are available for an individual Power Station then the higher three charging years ALF would be used in the calculation of the final ALF. In the event that only three charging years of complete output (FPN or actual metered) data are available then these three charging years would be used.

**Formatted:** Bullets and Numbering

14.15.81 Due to the aggregation of output (FPN or actual metered) data for dispersed generation (e.g. cascade hydro schemes), where a single generator BMU consists of geographically separated power stations, the ALF would be calculated based on the total output of the BMU and the overall TEC of those Power Stations.

**Formatted:** Bullets and Numbering

**Deleted:**

14.15.82 In the event that there are not three full charging years of an individual power station's output available, missing output (FPN or actual metered) data would be replaced by generic data for that generation plant type to ensure three charging years of information are available for the Power Station. The derivation of the generic data is described in paragraphs 14.15.85-14.15.88.

**Formatted:** Bullets and Numbering

14.15.83 Users will receive draft ALFs before 25<sup>th</sup> December of the charging year (t-1) for the charging year (t) and will have a period of 15 working days from date of publishing to notify the Company of any errors. Failure to agree changes relating to errors will be treated as a charging dispute under the CUSC.

**Deleted:** 83

**Deleted:** 84

**Deleted:** 87

**Deleted:** All Power Station ALFs are published in the Statement of Use of System Charges.

14.15.84 The ALFs used in the setting of final tariffs will be published in the annual Statement of Use of System Charges. Changes to ALFs after this publication will not result in changes to published tariffs (e.g. following dispute resolution).

**Formatted:** Bullets and Numbering

**Formatted:** Font: Arial (W1), 11 pt, Superscript

**Formatted:** Font: Arial (W1)

**Formatted:** Font: Arial (W1)

**Formatted:** Indent: Left: 1.27 cm

**Formatted:** Bullets and Numbering

**Derivation of Generic ALFs**

14.15.85 The generic ALF is derived from the average annual output of the ten most recently commissioned GB generation of a particular generation plant type that have at least five charging years' data, using an identical methodology to that used for the Power Station specific calculation described above. Where less than ten GB generators of a particular generation plant type exist, then data from all existing generators of that particular generation plant type will be used. Example generation plant type categories are listed below;

<b>Fuel Type</b>
Biomass
Coal
Gas
Hydro
Nuclear (by reactor type)
Oil & OCGTs
Pumped Storage
Onshore Wind
Offshore Wind
CHP

14.15.86 The Company will keep these categories under review and update as necessary. Where within a category there is a significant locational difference consideration will be given to zonal generic factors. The factors used will be published in the Statement of Use of System Charges and will be reviewed annually.

14.15.87 If a User can demonstrate that the generation plant type of a Power Station has changed, consideration will be given to the use of relevant generic ALF information in the calculation of their charges until sufficient specific data is available.

**Deleted:** u

14.15.88 For new and emerging generation plant types, where insufficient data is available to allow a generic ALF to be developed, The Company will use the best information available; e.g. from manufactures and data from use of similar technologies outside GB. The factor will be agreed with the relevant Generator. In the event of a disagreement the standard provisions for dispute in the CUSC will apply.

**Initial Revenue Recovery**

14.15.89 For the Peak Security background the initial tariff for generation is multiplied by the total forecast generation capacity and the PS flag to give the initial revenue recovery:

$$\sum_{Gi=1}^n (ITT_{GiPS} \times G_{Gi} \times F_{PS}) = ITRR_{GPS}$$

Where

- ITRR<sub>GPS</sub> = Peak Security Initial Transport Revenue Recovery for generation
- G<sub>Gi</sub> = Total forecast Generation for each generation zone (based on confidential User forecasts)
- F<sub>PS</sub> = Peak Security flag appropriate to that generator type
- n = Number of generation zones

**Formatted:** Font: Arial (W1)

**Formatted:** 1,2,3, Justified

**Deleted:** . ITRRb. . .

The initial revenue recovery for demand for the Peak Security background is calculated by multiplying the initial tariff by the total forecast metered triad demand:

$$\sum_{Di=1}^{14} (ITT_{DiPS} \times D_{Di}) = ITRR_{DPS}$$

Where:

- ITRR<sub>DPS</sub> = Peak Security Initial Transport Revenue Recovery for demand
- D<sub>Di</sub> = Total forecast Metered Triad Demand for each demand zone (based on confidential User forecasts)

**Formatted:** Font: Arial (W1), 11 pt

**Formatted:** Indent: Left: 1.27 cm

**Deleted:** <#>The next stage is to correct the Initial Transport Revenue Recovery figures above such that the 'correct' split of revenue between generation and demand is obtained. This has been determined to be 27:73 by the Authority for generation and demand respectively. In order to achieve the 'correct' generation/demand revenue split, a single additive constant C is calculated which is then added to the total zonal marginal km, both for generation and demand as below: ¶ <#>¶

**Formatted:** Bullets and Numbering

14.15.90 For the Year Round background, the initial tariff for generation is multiplied by the total forecast generation capacity and the ALF to give the initial revenue recovery:

$$\sum_{Gi=1}^n (ITT_{GiYR} \times G_{Gi} \times ALF) = ITRR_{GiYR}$$

Where:

- ITRR<sub>GYR</sub> = Year Round Initial Transport Revenue Recovery for generation
- ALF = Annual Load Factor appropriate to that generator

**Deleted:**  $\sum_{Gi=1}^{21} [(ZMkm_{Gi} + C$

$\sum_{Di=1}^{14} [(ZMkm_{Di} - C) \times EC \times$

¶ Where C is set such that ¶

14.15.91 Similar to the Peak Security background, the initial revenue recovery for demand for the Year Round background is calculated by multiplying the initial tariff by the total forecast metered triad demand:

$$\sum_{Di=1}^{14} (ITT_{D_{iYR}} \times D_{Di}) = ITRR_{D_{iYR}}$$

Where:

$ITRR_{D_{iYR}}$  = Year Round Initial Transport Revenue Recovery for demand

### Deriving the Final Local Tariff (£/kW)

#### Local Circuit Tariff

14.15.92 Generation with a local circuit tariff is calculated by multiplying the Year Round nodal marginal km along the local circuit by the expansion constant and the relevant local security factor (whether onshore or offshore) and summing across local circuits to give the local circuit tariff:

$$\sum_k \frac{NLMkm_{Gj}^L \times EC \times LocalSF_k}{1000} = CLT_{Gi}$$

Where

- $k$  = Local circuit  $k$  for generator
- $NLMkm_{Gj}^L$  = Year Round Nodal marginal km along local circuit  $k$  using local circuit expansion factor.
- $EC$  = Expansion Constant
- $LocalSF_k$  = Local Security Factor for circuit  $k$
- $CLT_{Gi}$  = Circuit Local Tariff (£/kW)

#### Onshore Local Substation Tariff

14.15.93 All chargeable generation is subject to the local substation tariff component which is determined by assessing the generation substation type which is the substation at the connection charging boundary, against three cost determining factors:

- (a) HV connection voltage – the voltage at the boundary between the User’s connection assets and the transmission system;
- (b) Sum of TEC at the generation substation – the combined TEC of all generation at the connecting substation; and
- (c) The level of redundancy at the generation substation – single busbar / single switch mesh connections are examples of no redundancy connections, whereas examples of connections with redundancy include double busbar and mesh sub station designs.

14.15.94 Using the above factors, the corresponding £/kW tariffs (quoted to 3dp) that will be applied during 2010/11 are:

Substation Rating (b)	Connection Type (c)	Substation Voltage (a)		
		132kV	275kV	400kV
<1320MW	No redundancy	0.133	0.081	0.065

Deleted:  $CTRR_D = p(CTT$

Deleted: ¶  
 ¶ Where¶  
 CTRR . = . "Generation / Demand split" corrected transport revenue recovery¶  
 . p . . = . Proportion of revenue to be recovered from demand¶  
 . C . . = . "Generation / Demand split" Correction constant (in km)¶  
 ¶ The above equations deliver corrected (£/MW) transport tariffs (CTT).¶  
 ¶  $(ZMkm_{Gi} + C) \times EC$   
 $(ZMkm_{Di} - C) \times EC \times LS$   
 ¶ So that¶  
 ¶  $\sum_{Gi=1}^{21} (CTT_{Gi} \times G_{Gi}) = CTRR$   
 and  
 $\sum_{Di=1}^{14} (CTT_{Di} \times D_{Di}) = CTRR$   
 ¶

Formatted: Justified

<1320MW	Redundancy	0.301	0.192	0.155
>=1320MW	No redundancy	n/a	0.257	0.208
>=1320MW	Redundancy	n/a	0.417	0.336

14.15.95 The process for calculating Local Substation Tariffs will be carried out for the first year of the price control and will subsequently be indexed by RPI for each subsequent year of the price control period.

14.15.96 The effective **Local Tariff** (£/kW) is calculated as the sum of the circuit and substation onshore and/or offshore components:

$$ELT_{Gi} = CLT_{Gi} + SLT_{Gi}$$

Where

ELT<sub>Gi</sub> = Effective Local Tariff (£/kW)  
 SLT<sub>Gi</sub> = Substation Local Tariff (£/kW)

14.15.97 Where tariffs do not change mid way through a charging year, final local tariffs will be the same as the effective tariffs:

ELT<sub>Gi</sub> = LT<sub>Gi</sub>  
 Where  
 LT<sub>Gi</sub> = Final Local Tariff (£/kW)

14.15.98 Where tariffs are changed part way through the year, the final tariffs will be calculated by scaling the effective tariffs to reflect that the tariffs are only applicable for part of the year and parties may have already incurred TNUoS liability.

$$FT_{Gi} = \frac{12 \times \left( ET_{Gi} \times \sum_{Gi=1}^n G_{Gi} - FL_{Gi} \right)}{b \times \sum_{Gi=1}^n G_{Gi}} \quad \text{and} \quad FT_{Di} = \frac{12 \times \left( ET_{Di} \times \sum_{Di=1}^{14} D_{Di} - FL_{Di} \right)}{b \times \sum_{Di=1}^{14} D_{Di}}$$

Where:

b = number of months the revised tariff is applicable for  
 FLL = Forecast local liability incurred over the period that the original tariff is applicable for

14.15.99 For the purposes of charge setting, the total local charge revenue is calculated by:

$$LCRR_G = \sum_{j=Gi} LT_{Gi} * G_j$$

Where

LCRR<sub>G</sub> = Local Charge Revenue Recovery  
 G<sub>j</sub> = Forecast chargeable Generation or Transmission Entry Capacity in kW (as applicable) for each generator (based on confidential information received from Users)

**Offshore substation local tariff**

14.15.100 All offshore chargeable generation is subject to an offshore substation tariff. The offshore substation tariff shall be the sum of transformer, switchgear and platform components.

14.15.101 Each tariff component, expressed in £/kW, shall be the ratio of the Offshore Transmission Owner revenue (£) and rating associated with the transformers, switchgear or platform (kW) at each offshore substation. The Offshore Transmission

Owner revenue of each tariff component shall include that associated with asset spares. In the case of the platform component, the relevant rating shall be the lower of the transformer or switchgear ratings. As with the offshore circuit expansion factors, the Offshore Transmission Owner revenue associated with each tariff component shall be averaged over the remaining years of the NETSO price control.

14.15.102 Offshore Transmission Owner revenue associated with interest during construction and project development overheads will be attributed to the relevant asset category with which it is associated. If these or any other costs included in the Offshore Transmission Owner revenue are not readily attributable to a given asset category, they will be pro-rated across the various asset categories based on their relative cost.

14.15.103 For 2010/11 a discount of £0.345590/kW shall be provided to the offshore substation tariff to reflect the average cost of civil engineering for onshore substations. This will be inflated by RPI each year and reviewed every price control period.

14.15.104 Offshore substation tariffs shall be inflated by RPI each year and reviewed every price control period.

14.15.105 The revenue from the offshore substation local tariff is calculated by:

$$SLTR = \sum_{\text{All offshore substations}} \left( SLT_k \times \sum_k Gen_k \right)$$

Formatted: Indent: Left: 3.81 cm

Where:

SLT<sub>k</sub> = the offshore substation tariff for substation k  
 Gen<sub>k</sub> = the generation connected to offshore substation k

**The Residual Tariff**

14.15.106 The total revenue to be recovered through TNUoS charges is determined each year with reference to the Transmission Licensees' Price Control formulas less the costs expected to be recovered through Pre-Vesting connection charges. Hence in any given year t, a target revenue figure for TNUoS charges (TRR<sub>t</sub>) is set after adjusting for any under or over recovery for and including, the small generators discount is as follows:

$$TRR_t = R_t - PVC_t - SG_{t-1}$$

Where

TRR<sub>t</sub> = TNUoS Revenue Recovery target for year t  
 R<sub>t</sub> = Forecast Revenue allowed under The Company's RPI-X Price Control Formula for year t (this term includes a number of adjustments, including for over/under recovery from the previous year). For further information, refer to Special Condition D2 of The Company's Transmission Licence.  
 PVC<sub>t</sub> = Forecast Revenue from Pre-Vesting connection charges for year t  
 SG<sub>t-1</sub> = The proportion of the under/over recovery included within R<sub>t</sub> which relates to the operation of statement C13 of the The Company Transmission Licence. Should the operation of statement C13 result in an under recovery in year t – 1, the SG figure will be positive and vice versa for an over recovery.

14.15.107 In normal circumstances, the revenue forecast to be recovered from the initial transport tariffs will not equate to the total revenue target. This is due to a number of factors. For example, the transport model assumes, for simplicity, smooth incremental transmission investments can be made. In reality, transmission investment can only be made in discrete 'lumps'. The transmission system has been planned and developed

Deleted: corrected

over a long period of time. Forecasts and assessments used for planning purposes will not have been borne out precisely by events and therefore some distinction between an optimal system for one year and the actual system can be expected.

14.15.108 As a result of the factors above, in order to ensure adequate revenue recovery, a constant non-locational **Residual Tariff** for generation and demand is calculated, which includes infrastructure substation asset costs. It is added to the initial transport tariffs for both Peak Security and Year Round backgrounds so that the correct generation / demand revenue split is maintained and the total revenue recovery is achieved.

Deleted: corrected

$$RT_D = \frac{(p \times TRR) - ITRR_{DPS} - ITRR_{DYS}}{\sum_{Di=1}^{14} D_{Di}}$$

$$RT_G = \frac{[(1-p) \times TRR] - ITRR_{GPS} - ITRR_{GYS} - LCRR_G}{\sum_{Gi=1}^n G_{Gi}}$$

Deleted:  $RT_D = \frac{(p \times TRR)}{\sum_{Di=1}^{14}}$

Deleted:  $RT_G = [(1-p) \times$

Where  
 RT = Residual Tariff (£/MW)  
 p = Proportion of revenue to be recovered from demand

**Final £/kW Tariff**

14.15.109 The effective Transmission Network Use of System tariff (TNUoS) can now be calculated as the sum of the initial transport wider tariffs for Peak Security and Year Round backgrounds, the non-locational residual tariff and the local tariff:

Deleted: corrected

$$ET_{Gi} = \frac{ITT_{Gi}^{PS} + ITT_{Gi}^{YR} + RT_{G_i} + LT_{Gi}}{1000} \quad \text{and} \quad ET_{Di} = \frac{ITT_{Di}^{PS} + ITT_{Di}^{YR} + RT_D}{1000}$$

Deleted:

Deleted:

Where  
 ET = Effective TNUoS Tariff expressed in £/kW (ET<sub>Gi</sub> would only be applicable to a Power Station with a PS flag of 1 and ALF of 1; in all other circumstances ITT<sub>GPS</sub> and ITT<sub>GIS</sub> will be applied using Power Station specific data)

Formatted: Indent: Left: 0.46 cm, Tabs: Not at 2 cm

For the purposes of the annual Statement of Use of System Charges ET<sub>Gi</sub> will be published as ITT<sub>GPS</sub>; ITT<sub>GIS</sub>, RT<sub>G</sub> and LT<sub>Gi</sub>

Formatted: Indent: Left: 0 cm

14.15.110 Where tariffs do not change mid way through a charging year, final demand and generation tariffs will be the same as the effective tariffs.

$$FT_{Gi} = ET_{Gi} \quad \text{and} \quad FT_{Di} = ET_{Di}$$

14.15.111 Where tariffs are changed part way through the year, the final tariffs will be calculated by scaling the effective tariffs to reflect that the tariffs are only applicable for part of the year and parties may have already incurred TNUoS liability.

$$FT_{Gi} = \frac{12 \times \left( ET_{Gi} \times \sum_{Gi=1}^n G_{Gi} - FL_{Gi} \right)}{b \times \sum_{Gi=1}^n G_{Gi}} \quad \text{and} \quad FT_{Di} = \frac{12 \times \left( ET_{Di} \times \sum_{Di=1}^{14} D_{Di} - FL_{Di} \right)}{b \times \sum_{Di=1}^{14} D_{Di}}$$

Deleted:  $FT_{Gi} = \frac{12 \times (ET_{Gi})}{b \times \sum_{Gi=1}^n G_{Gi}}$

Deleted:

Deleted:

Where:

b = number of months the revised tariff is applicable for  
 FL = Forecast liability incurred over the period that the original tariff is applicable for

Note: The  $ET_{G_i}$  element used in the formula above will be based on an individual Power Stations' PS flag and ALF for Power Station  $G_{G_i}$ , aggregated to ensure overall correct revenue recovery.

14.15.112 If the final demand TNUoS Tariff results in a negative number then this is collared to £0/kW with the resultant non-recovered revenue smeared over the remaining demand zones:

If  $FT_{D_i} < 0$ , then  $i = 1$  to  $z$

Therefore,

$$NRRT_D = \frac{\sum_{i=1}^z (FT_{D_i} \times D_{D_i})}{\sum_{i=z+1}^{14} D_{D_i}}$$

Therefore the revised Final Tariff for the demand zones with positive Final tariffs is given by:

For  $i = 1$  to  $z$ :  $RFT_{D_i} = 0$

For  $i = z+1$  to  $14$ :  $RFT_{D_i} = FT_{D_i} + NRRT_D$

Where

$NRRT_D$  = Non Recovered Revenue Tariff (£/kW)

$RFT_{D_i}$  = Revised Final Tariff (£/kW)

14.15.113 The tariffs applicable for any particular year are detailed in The Company's **Statement of Use of System Charges**, which is available from the **Charging website**. Archived tariff information may also be obtained from the Charging website.

14.15.114 The zonal maps referenced in The Company's **Statement of Use of System Charges** and available on the **Charging website** contain detailed information for the charging year in question of which Grid Supply Points fall into which TNUoS zones.

14.15.115 New Grid Supply Points will be classified into zones on the following basis:

- For demand zones, according to the GSP Group to which the Grid Supply Point is allocated for energy market settlement purposes.
- For generation zones, with reference to the geographic proximity to existing zones and, where close to a boundary between existing zones, with reference to the marginal costs arising from transport model studies. The GSP will then be allocated to the zone, which contains the most similar marginal costs.

14.15.116 The Company has available, upon request, the DCLF ICRP transport model, tariff model template and data necessary to run the model, consisting of nodal values of generation and demand connection points to the NETS. The model and data will enable the basic nodal charges to be determined and will also allow sensitivity analysis concerning alternative developments of generation and demand to be undertaken. The model is available from the Charging Team and whilst it is free of charge, it is provided under licence to restrict its distribution and commercial use.

**Formatted:** Indent: Left: 1.27 cm, Hanging: 0.75 cm, Bulleted + Level: 1 + Aligned at: 0 cm + Tab after: 0.63 cm + Indent at: 0.63 cm, Tabs: 2.02 cm, List tab + Not at 0.63 cm + 1.27 cm

**Formatted:** Indent: Left: 1.25 cm, Hanging: 0.75 cm, Bulleted + Level: 1 + Aligned at: 0 cm + Tab after: 0.63 cm + Indent at: 0.63 cm, Tabs: 2 cm, List tab + Not at 0.63 cm + 1.27 cm



14.15.117 The Company will be pleased to run specific sensitivity studies for Users under a separate study contract in line with the fees set out in the **Statement of Use of System Charges**. Please contact the **Charging Team**.

14.15.118 The factors which will affect the level of TNUoS charges from year to year include:

- the forecast level of peak demand on the system
- the Price Control formula (including the effect of any under/over recovery from the previous year)
- the expansion constant
- the locational security factor
- the PS flag
- the ALF of a generator
- changes in the transmission network
- HVDC circuit impedance calculation and
- changes in the pattern of generation capacity and demand

Deleted:

Deleted: ,

Deleted: ),

Deleted: ,

Deleted: ,

Deleted: and

Deleted: .

Formatted: Bulleted + Level: 1 + Aligned at: 3.81 cm + Tab after: 4.51 cm + Indent at: 4.51 cm, Tabs: Not at 1.27 cm

14.15.119 In accordance with Standard Licence Condition C13, generation directly connected to the NETS 132kV transmission network which would normally be subject to generation TNUoS charges but would not, on the basis of generating capacity, be liable for charges if it were connected to a licensed distribution network qualifies for a reduction in transmission charges by a designated sum, determined by the Authority. Any shortfall in recovery will result in a unit amount increase in demand charges to compensate for the deficit. Further information is provided in the Statement of the Use of System Charges.

**Stability & Predictability of TNUoS tariffs**

14.15.120 A number of provisions are included within the methodology to promote the stability and predictability of TNUoS tariffs. These are described in 14.29,

Deleted: 8

## 14.16 Derivation of the Transmission Network Use of System Energy Consumption Tariff and Short Term Capacity Tariffs

- 14.16.1 For the purposes of this section, Lead Parties of Balancing Mechanism (BM) Units that are liable for Transmission Network Use of System Demand Charges are termed Suppliers.
- 14.16.2 Following calculation of the Transmission Network Use of System £/kW Demand Tariff (as outlined in Chapter 2: Derivation of the TNUoS Tariff) for each GSP Group is calculated as follows:

$$\text{p/kWh Tariff} = \frac{(\text{NHHD}_F * \text{£/kW Tariff} - \text{FL}_G) * 100}{\text{NHC}_G}$$

Where:

**£/kW Tariff** = The £/kW Effective Demand Tariff (£/kW), as calculated previously, for the GSP Group concerned.

**NHHD<sub>F</sub>** = The Company's forecast of Suppliers' non-half-hourly metered Triad Demand (kW) for the GSP Group concerned. The forecast is based on historical data.

**FL<sub>G</sub>** = Forecast Liability incurred for the GSP Group concerned.

**NHC<sub>G</sub>** = The Company's forecast of GSP Group non-half-hourly metered total energy consumption (kWh) for the period 16:00 hrs to 19:00hrs inclusive (i.e. settlement periods 33 to 38) inclusive over the period the tariff is applicable for the GSP Group concerned.

### Short Term Transmission Entry Capacity (STTEC) Tariff

- 14.16.3 The Short Term Transmission Entry Capacity (STTEC) tariff for positive zones is derived from the Effective Tariff (ET<sub>Gi</sub>) annual TNUoS £/kW tariffs (14.15.109). If multiple set of tariffs are applicable within a single charging year, the Final Tariff used in the STTEC calculation will be prorated in an identical manner to that used when calculating a generators annual liability. The periods over which the tariff would be prorated would be identical to the periods used when calculating the wider tariff (i.e. over the whole financial year, not just the period that the STTEC is applicable for). STTECs will not be reconciled following a mid year charge change. The premium associated with the flexible product is associated with the analysis that 90% of the annual charge is linked to the system peak. The system peak is likely to occur in the period of November to February inclusive (120 days, irrespective of leap years). The calculation for positive generation zones is as follows:

Deleted: relevant

$$\frac{FT_{Gi} \times 0.9 \times \text{STTEC Period}}{120} = \text{STTEC tariff (£/kW/period)}$$

Where:

FT = Final annual TNUoS Tariff expressed in £/kW  
 Gi = Generation zone  
 STTEC Period = A period applied for in days as defined in the CUSC

14.16.4 For the avoidance of doubt, the charge calculated under 14.16.3 above will represent each single period application for STTEC. Requests for multiple STTEC periods will result in each STTEC period being calculated and invoiced separately.

14.16.5 The STTEC tariff for generators with negative final tariffs is set to zero to prevent Users receiving greater than 100% of the annual TNUoS payment that would have been received for that capacity under a firm TEC.

### Limited Duration Transmission Entry Capacity (LDTEC) Tariffs

14.16.6 The Limited Duration Transmission Entry Capacity (LDTEC) tariff for positive zones is derived from the equivalent zonal STTEC tariff for up to the initial 17 weeks of LDTEC in a given charging year (whether consecutive or not). For the remaining weeks of the year, the LDTEC tariff is set to collect the balance of the annual TNUoS liability over the maximum duration of LDTEC that can be granted in a single application. If multiple set of tariffs are applicable within a single charging year, the Final Tariff used in the LDTEC calculation will be prorated in an identical manner to that used when calculating a generators annual liability. The periods over which the tariff would be prorated would be identical to the periods used when calculating the wider tariff (ie over the whole financial year, not just the period that the STTEC is applicable for). LDTECs will not be reconciled following a mid year charge change:

Initial 17 weeks (high rate):

$$\text{LDTEC tariff (£/kW/week)} = \frac{FT_{G_i} \times 0.9 \times 7}{120}$$

Remaining weeks (low rate):

$$\text{LDTEC tariff (£/kW/week)} = \frac{FT_{G_i} \times 0.1075 \times 7}{316 - 120} \times (1 + P)$$

where  $FT$  is the final annual TNUoS tariff expressed in £/kW;

$G_i$  is the generation TNUoS zone; and

$P$  is the premium in % above the annual equivalent TNUoS charge as determined by The Company, which shall have the value 0.

14.16.7 The LDTEC tariff for generators with negative final tariffs is set to zero to prevent Users receiving greater than 100% of the annual TNUoS payment that would have been received for that capacity under a firm TEC.

14.16.8 The tariffs applicable for any particular year are detailed in The Company's **Statement of Use of System Charges** which is available from the **Charging website**. Historical tariffs are also available on the **Charging website**.

## 14.17 Demand Charges

### Parties Liable for Demand Charges

14.17.1 The following parties shall be liable for demand charges:

- The Lead Party of a Supplier BM Unit;
- Power Stations with a Bilateral Connection Agreement;
- Parties with a Bilateral Embedded Generation Agreement

**Formatted:** Indent: Left: 2.54 cm, Bulleted + Level: 1 + Aligned at: 0 cm + Tab after: 0.63 cm + Indent at: 0.63 cm, Tabs: 2.54 cm, List tab + Not at 0.63 cm + 1.27 cm

14.17.2 Classification of parties for charging purposes provides an illustration of how a party is classified in the context of Use of System charging and refers to the paragraphs most pertinent to each party.

**Formatted:** Indent: Left: 2.54 cm, Bulleted + Level: 1 + Aligned at: 0 cm + Tab after: 0.63 cm + Indent at: 0.63 cm, Tabs: 2.54 cm, List tab + Not at 0.63 cm + 1.27 cm

### Basis of Demand Charges

14.17.3 Demand charges are based on a de-minimus £0/kW charge for Half Hourly and £0/kWh for Non Half Hourly metered demand.

14.17.4 Chargeable Demand Capacity is the value of Triad demand (kW). Chargeable Energy Capacity is the energy consumption (kWh). The definition of both these terms is set out below.

14.17.5 If there is a single set of demand tariffs within a charging year, the Chargeable Demand Capacity is multiplied by the relevant demand tariff, for the calculation of demand charges.

14.17.6 If there is a single set of energy tariffs within a charging year, the Chargeable Energy Capacity is multiplied by the relevant energy consumption tariff for the calculation of energy charges..

14.17.7 If multiple sets of demand tariffs are applicable within a single charging year, demand charges will be calculated by multiplying the Chargeable Demand Capacity by the relevant tariffs pro rated across the months that they are applicable for, as below,

$$Annual\ Liability_{Demand} = Chargeable\ Demand\ Capacity \times \left( \frac{(a \times Tariff\ 1) + (b \times Tariff\ 2)}{12} \right)$$

where:

Tariff 1 = Original tariff,

Tariff 2 = Revised tariff,

a = Number of months over which the original tariff is applicable,

b = Number of months over which the revised tariff is applicable.

**Formatted:** Indent: Left: 2.54 cm, Bulleted + Level: 1 + Aligned at: 0 cm + Tab after: 0.63 cm + Indent at: 0.63 cm, Tabs: 2.54 cm, List tab + Not at 0.63 cm + 1.27 cm

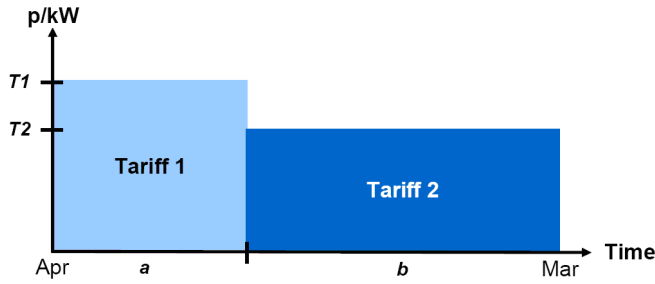

14.17.8 If multiple sets of energy tariffs are applicable within a single charging year, energy charges will be calculated by multiplying relevant Tariffs by the Chargeable Energy Capacity over the period that the tariffs are applicable for and summing over the year.

$$Annual Liability_{Energy} = Tariff\ 1 \times \sum_{T1_s}^{T1_E} Chargeable\ Energy\ Capacity + Tariff\ 2 \times \sum_{T2_s}^{T2_E} Chargeable\ Energy\ Capacity$$

Where:

- T1<sub>s</sub> = Start date for the period for which the original tariff is applicable,
- T1<sub>E</sub> = End date for the period for which the original tariff is applicable,
- T2<sub>s</sub> = Start date for the period for which the revised tariff is applicable,
- T2<sub>E</sub> = End date for the period for which the revised tariff is applicable.

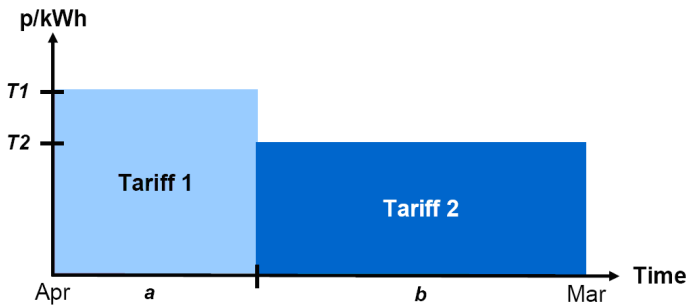

**Supplier BM Unit**

14.17.9 A Supplier BM Unit charges will be the sum of its energy and demand liabilities where::

- The Chargeable Demand Capacity will be the average of the Supplier BM Unit's half-hourly metered demand during the Triad (and the £/kW tariff), and
- The Chargeable Energy Capacity will be the Supplier BM Unit's non half-hourly metered energy consumption over the period 16:00 hrs to 19:00 hrs inclusive every day over the Financial Year (and the p/kWh tariff).

**Formatted:** Indent: Left: 2.5 cm, Bulleted + Level: 1 + Aligned at: 0 cm + Tab after: 0.63 cm + Indent at: 0.63 cm, Tabs: 3.14 cm, List tab + Not at 0.63 cm + 1.27 cm

**Formatted:** Indent: Left: 2.48 cm, Bulleted + Level: 1 + Aligned at: 0 cm + Tab after: 0.63 cm + Indent at: 0.63 cm, Tabs: 3.12 cm, List tab + Not at 0.63 cm + 1.27 cm

**Power Stations with a Bilateral Connection Agreement and Licensable Generation with a Bilateral Embedded Generation Agreement**

14.17.10 The Chargeable Demand Capacity for a Power Station with a Bilateral Connection Agreement or Licensable Generation with a Bilateral Embedded Generation Agreement will be based on the average of the net import over each Triad leg of the BM Units associated with the Power Station (in Appendix C of its Bilateral Connection Agreement or Bilateral Embedded Generation Agreement, including metered additional load) during the Triad.

**Exemptible Generation and Derogated Distribution Interconnectors with a Bilateral Embedded Generation Agreement**

14.17.11 The Chargeable Demand Capacity for Exemptible Generation and Derogated Distribution Interconnectors with a Bilateral Embedded Generation Agreement will be based on the average of the metered volume of each BM Unit specified in Appendix C of the Bilateral Embedded Generation Agreement during the Triad.

**Small Generators Tariffs**

14.17.12 In accordance with Standard Licence Condition C13, any under recovery from the MAR arising from the small generators discount will result in a unit amount of increase to all GB demand tariffs.

**The Triad**

14.17.13 The Triad is used as a short hand way to describe the three settlement periods of highest transmission system demand within a Financial Year, namely the half hour settlement period of system peak demand and the two half hour settlement periods of next highest demand, which are separated from the system peak demand and from each other by at least 10 Clear Days, between November and February of the Financial Year inclusive. Exports on directly connected Interconnectors and Interconnectors capable of exporting more than 100MW to the Total System shall be excluded when determining the system peak demand. An illustration is shown below.

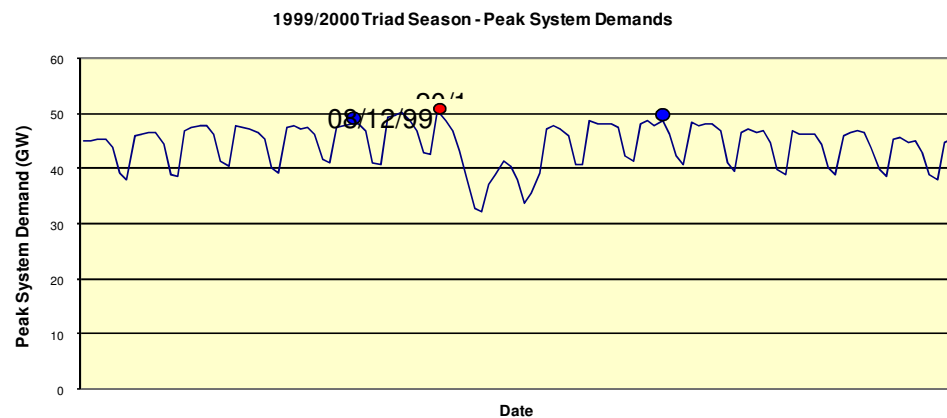

**Half-hourly metered demand charges**

14.17.14 For Supplier BMUs and BM Units associated with Exemptible Generation and Derogated Distribution Interconnectors with a Bilateral Embedded Generation

Agreement, if the average half-hourly metered volume over the Triad results in an import, the Chargeable Demand Capacity will be positive resulting in the BMU being charged. If the average half-hourly metered volume over the Triad results in an export, the Chargeable Demand Capacity will be negative resulting in the BMU being paid. For the avoidance of doubt, parties with Bilateral Embedded Generation Agreements that are liable for Generation charges will not be eligible for a negative demand credit.

**Netting off within a BM Unit**

14.17.15 The output of generators and Distribution Interconnectors registered as part of a Supplier BM Unit will have already been accounted for in the Supplier BM Unit demand figures upon which The Company Transmission Network Use of System Demand charges are based.

**Monthly Charges**

14.17.16 Throughout the year Users' monthly demand charges will be based on their forecasts of:

- half-hourly metered demand to be supplied during the Triad for each BM Unit, multiplied by the relevant zonal £/kW tariff; and
- non-half hourly metered energy to be supplied over the period 16:00 hrs to 19:00 hrs inclusive every day over the Financial Year for each BM Unit, multiplied by the relevant zonal p/kWh tariff

Users' annual TNUoS demand charges are based on these forecasts and are split evenly over the 12 months of the year. Users have the opportunity to vary their demand forecasts on a quarterly basis over the course of the year, with the demand forecast requested in February relating to the next Financial Year. Users will be notified of the timescales and process for each of the quarterly updates. The Company will revise the monthly Transmission Network Use of System demand charges by calculating the annual charge based on the new forecast, subtracting the amount paid to date, and splitting the remainder evenly over the remaining months. For the avoidance of doubt, only positive demand forecasts (i.e. representing an import from the system) will be accepted.

**Formatted:** Indent: Left: 2.54 cm, Hanging: 0.75 cm, Bulleted + Level: 1 + Aligned at: 0 cm + Tab after: 0.63 cm + Indent at: 0.63 cm, Tabs: 3.29 cm, List tab + Not at 0.63 cm + 1.27 cm

**Formatted:** Indent: Left: 2.54 cm, Hanging: 0.75 cm, Bulleted + Level: 1 + Aligned at: 0 cm + Tab after: 0.63 cm + Indent at: 0.63 cm, Tabs: 3.29 cm, List tab + Not at 0.63 cm + 1.27 cm

14.17.17 Users should submit reasonable demand forecasts in accordance with the CUSC. The Company shall use the following methodology to derive a forecast to be used in determining whether a User's forecast is reasonable, in accordance with the CUSC, and this will be used as a replacement forecast if the User's total forecast is deemed unreasonable. The Company will, at all times, use the latest available Settlement data.

For existing Users:

- i) The User's Triad demand for the preceding Financial Year will be used where User settlement data is available and where The Company calculates its forecast before the Financial Year. Otherwise, the User's average weekday settlement period 35 half-hourly metered (HH) demand in the Financial Year to date is compared to the equivalent average demand for the corresponding days in the preceding year. The percentage difference is then applied to the User's HH demand at Triad in the preceding Financial Year to derive a forecast of the User's HH demand at Triad for this Financial Year.
- ii) The User's non half-hourly metered (NHH) energy consumption over the period 16:00 hrs to 19:00 hrs every day in the Financial Year to date is compared to the equivalent energy consumption over the corresponding days in the preceding year. The percentage difference is then applied to the User's total NHH energy

**Formatted:** Indent: Left: 2.87 cm, Numbered + Level: 1 + Numbering Style: i, ii, iii, ... + Start at: 1 + Alignment: Left + Aligned at: 0 cm + Tab after: 1 cm + Indent at: 1 cm, Tabs: 2.62 cm, List tab + Not at 1 cm + 1.27 cm

**Formatted:** Indent: Left: 2.87 cm, Numbered + Level: 1 + Numbering Style: i, ii, iii, ... + Start at: 2 + Alignment: Tab + Aligned at: 0 cm + Tab after: 1 cm + Indent at: 1 cm, Tabs: 2.62 cm, List tab + Not at 1 cm + 1.27 cm

consumption in the preceding Financial Year to derive a forecast of the User's NHH energy consumption for this Financial Year.

For new Users who have completed a Use of System Supply Confirmation Notice in the current Financial Year:

iii) The User's average weekday settlement period 35 half-hourly metered (HH)\* demand over the last complete month for which The Company has settlement data is calculated. Total system average HH demand for weekday settlement period 35 for the corresponding month in the previous year is compared to total system HH demand at Triad in that year and a percentage difference is calculated. This percentage is then applied to the User's average HH demand for weekday settlement period 35 over the last month to derive a forecast of the User's HH demand at Triad for this Financial Year.

**Formatted:** Indent: Left: 2.87 cm, Numbered + Level: 1 + Numbering Style: i, ii, iii, ... + Start at: 3 + Alignment: Left + Aligned at: 0 cm + Tab after: 1 cm + Indent at: 1 cm, Tabs: 2.62 cm, List tab + Not at 1 cm + 1.27 cm

iv) The User's non half-hourly metered (NHH) energy consumption over the period 16:00 hrs to 19:00 hrs every day over the last complete month for which The Company has settlement data is noted. Total system NHH energy consumption over the corresponding month in the previous year is compared to total system NHH energy consumption over the remaining months of that Financial Year and a percentage difference is calculated. This percentage is then applied to the User's NHH energy consumption over the month described above, and all NHH energy consumption in previous months is added, in order to derive a forecast of the User's NHH metered energy consumption for this Financial Year.

**Formatted:** Indent: Left: 2.87 cm, Numbered + Level: 1 + Numbering Style: i, ii, iii, ... + Start at: 3 + Alignment: Left + Aligned at: 0 cm + Tab after: 1 cm + Indent at: 1 cm, Tabs: 2.62 cm, List tab + Not at 1 cm + 1.27 cm

14.17.18 ~~14.28~~ Determination of The Company's Forecast for Demand Charge Purposes illustrates how the demand forecast will be calculated by The Company.

**Deleted:** 7

## Reconciliation of Demand Charges

14.17.19 The reconciliation process is set out in the CUSC. The demand reconciliation process compares the monthly charges paid by Users against actual outturn charges. Due to the Settlements process, reconciliation of demand charges is carried out in two stages; initial reconciliation and final reconciliation.

### Initial Reconciliation of demand charges

14.17.20 The initial reconciliation process compares Users' demand forecasts and corresponding monthly charges paid over the year against actual outturn data (using latest Settlement data available at the time) and corresponding charges. Initial reconciliation is carried out in two parts; Initial Reconciliation Part 1 deals with the reconciliation of half-hourly metered demand charges and Initial Reconciliation Part 2 deals with the reconciliation of non-half-hourly metered demand charges.

### Initial Reconciliation Part 1– Half-hourly metered demand

14.17.21 The Company will identify the periods forming the Triad once it has received Central Volume Allocation data from the Settlement Administration Agent for all days up to and including the last day of February. Once The Company has notified Users of the periods forming the Triad they will not be changed even if disputes are subsequently resolved which would change the periods forming the Triad.

14.17.22 Initial outturn charges for half-hourly metered demand will be determined using the latest available data of actual average Triad demand (kW) multiplied by the zonal demand tariff(s) (£/kW) applicable to the months concerned for each zone for that Financial Year. These actual values are then reconciled against the monthly charges paid in respect of half-hourly demand.



### Initial Reconciliation Part 2 – Non-half-hourly metered demand

14.17.23 Actual payments for non-half-hourly metered demand will be determined using the latest available actual energy consumption data (kWh) for the period 16:00 hrs to 19:00 hrs inclusive (i.e. settlement periods 33 to 38) over the year multiplied by the energy consumption tariff(s) (p/kWh) applicable to the months concerned for each zone. These actual values are then reconciled against the monthly charges paid in respect of non-half-hourly energy consumption.

### Final Reconciliation of demand charges

14.17.24 The final reconciliation process compares Users' charges (as calculated during the initial reconciliation process using the latest available data) against final outturn demand charges (based on final settlement data).

14.17.25 Final actual charges will be determined using the final demand reconciliation data taken from the Final Reconciliation Settlement Run or the Final Reconciliation Volume Allocation Run.

### Reconciliation of manifest errors

14.17.26 In the event that a manifest error, or multiple errors in the calculation of TNUoS tariffs results in a material discrepancy in a Users TNUoS tariff, the reconciliation process for all Users qualifying under Section 14.17.28 will be in accordance with Sections 14.17.20 to 14.17.25. The reconciliation process shall be carried out using recalculated TNUoS tariffs. Where such reconciliation is not practicable, a post-year reconciliation will be undertaken in the form of a one-off payment.

14.17.27 A manifest error shall be defined as any of the following:

- a) an error in the transfer of relevant data between the Transmission Licensees or Distribution Network Operators;
- b) an error in the population of the Transport Model with relevant data;
- c) an error in the function of the Transport Model; or
- d) an error in the inputs or function of the Tariff Model.

14.17.28 A manifest error shall be considered material in the event that such an error or, the net effect of multiple errors, has an impact of the lesser of either:

- a) an error in a User's TNUoS tariff of at least +/-£0.50/kWh; or
- b) an error in a User's TNUoS tariff which results in an error in the annual TNUoS charge of a User in excess of +/-£250,000.

14.17.29 A manifest error shall only be reconciled if it has been identified within the charging year for which the error has an effect. Errors identified outside of this period will not be eligible for reconciliation retrospectively.

### Further Information

14.17.30 ~~14.25~~ Reconciliation of Demand Related Transmission Network Use of System Charges of this statement illustrates how the monthly charges are reconciled against the actual values for demand and consumption for half-hourly and non-half-hourly metered demand respectively.

Deleted: 4

14.17.31 **The Statement of Use of System Charges** contains the £/kW zonal demand tariffs, and the p/kWh energy consumption tariffs for the current Financial Year.

14.17.32 14.27. Transmission Network Use of System Charging Flowcharts of this statement contains flowcharts demonstrating the calculation of these charges for those parties liable.

Deleted: 6

## 14.18 Generation charges

### Parties Liable for Generation Charges

14.18.1 The following CUSC parties shall be liable for generation charges:

- i) Parties of Generators that have a Bilateral Connection Agreement with The Company.
- ii) Parties of Licensable Generation that have a Bilateral Embedded Generation Agreement with The Company.

14.18.2 14.26 Classification of parties for charging purposes provides an illustration of how a party is classified in the context of Use of System charging and refers to the relevant paragraphs most pertinent to each party.

### Structure of Generation Charges

14.18.3 Generation Tariffs are comprised of Wider and Local Tariffs. The Wider Tariff is comprised of (i) a Peak Security element, (ii) a Year Round element and (iii) a residual element. The Peak Security element of the Wider Tariff is not applicable for intermittent generators as the PS flag is set to zero.

14.18.4 The Local Tariff contains a substation element and may also contain a circuit element. Specifically, all transmission connected generation will be liable to pay a local substation charge, with some of these also being liable to pay a local circuit charge. For the avoidance of doubt, embedded generation has a zero local tariff.

14.18.5 The intention of the charging rules is to charge the same physical entity only once.

14.18.6 The basis of the generation charge for Power Stations is the Chargeable Capacity and the short-term chargeable capacity (as defined below for positive and negative charging zones).

14.18.7 If there is a single set of Wider and Local generation tariffs within a charging year, the Chargeable Capacity is multiplied by the relevant generation tariff to calculate the annual liability of a generator.

$$\text{Local Annual Liability} = \text{Chargeable Capacity} \times \text{Local Tariff}$$

The Wider Tariff is broken down into three components as described in 14.18.3. The breakdown of the Wider Charge for Conventional and Intermittent Power Stations are given below:

Conventional -

$$\text{Wider Annual Liability} = \text{Chargeable Capacity} \times (\text{PSTariff} + (\text{YRTariff} \times \text{ALF}) + \text{ResidualTariff})$$

Intermittent -

$$\text{Wider Annual Liability} = \text{Chargeable Capacity} \times ((\text{YRTariff} \times \text{ALF}) + \text{ResidualTariff})$$

Where:

PS Tariff = Wider Peak Security Tariff

YR Tariff = Wider Year Round Tariff

**Formatted:** Indent: Left: 2.87 cm, Hanging: 1.27 cm, Numbered + Level: 1 + Numbering Style: i, ii, iii, ... + Start at: 1 + Alignment: Left + Aligned at: 0 cm + Tab after: 1.27 cm + Indent at: 0.63 cm, Tabs: 4.14 cm, List tab + Not at 1.27 cm

**Formatted:** Indent: Left: 2.87 cm, Hanging: 1.27 cm, Numbered + Level: 1 + Numbering Style: i, ii, iii, ... + Start at: 1 + Alignment: Left + Aligned at: 0 cm + Tab after: 1.27 cm + Indent at: 0.63 cm, Tabs: 4.14 cm, List tab + Not at 1.27 cm

**Deleted:** 5

**Deleted:** Charges

**Deleted:** Charges,

**Deleted:** latter of which

**Formatted:** Indent: Left: 2.87 cm

14.18.8 If multiple sets of Wider and Local generation tariffs are applicable within a single charging year, the Chargeable Capacity is multiplied by the relevant tariffs pro rated over the entire charging year, across the months that they are applicable for.

$$\text{Annual Liability} = \left( \frac{a \times \text{Liability 1} + b \times \text{Liability 2}}{12} \right)$$

where:

Liability 1 = Original annual liability,

Liability 2 = Revised annual liability,

a = Number of months over which the original liability is applicable,

b = Number of months over which the revised liability is applicable.

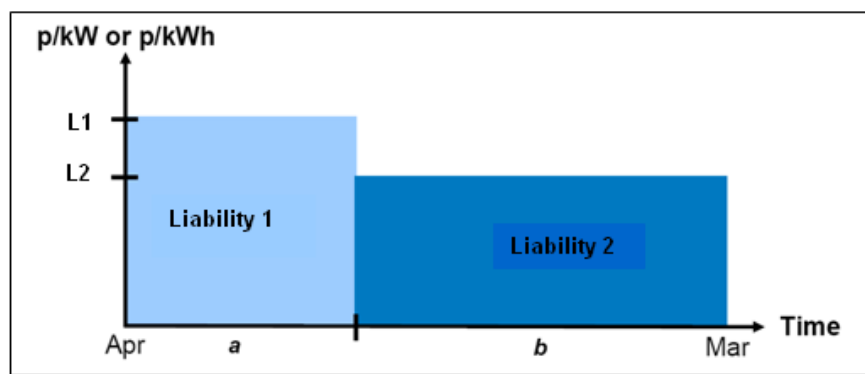

Deleted: Tariff

Deleted: tariff

Deleted: Tariff

Deleted: tariff

Deleted: tariff

Deleted: tariff

Deleted: p/kW or p/kWh

14.18.9 For the avoidance of doubt if there are multiple sets of Wider and Local generation tariffs applicable within a single charging year and a tariff changes from being positive to negative or vice versa, the Chargeable Capacity for the entire charging year will be determined based on the net position of the pro rated tariffs for each affected generator.

### Basis of Wider Generation Charges

#### Generation with positive wider tariffs

14.18.10 The Chargeable Capacity for Power Stations with positive wider generation tariffs is the highest Transmission Entry Capacity (TEC) applicable to that Power Station for that Financial Year. A Power Station should not exceed its TEC as to do so would be in breach of the CUSC, except where it is entitled to do so under the specific circumstances laid out in the CUSC (e.g. where a User has been granted Short Term Transmission Entry Capacity, STTEC). For the avoidance of doubt, TNUoS Charges will be determined on the TEC held by a User as specified within a relevant bilateral agreement regardless of whether or not it enters into a temporary TEC Exchange (as defined in the CUSC).

14.18.11 The short-term chargeable capacity for Power Stations situated with positive generation tariffs is any approved STTEC or LDTEC applicable to that Power Station during a valid STTEC Period or LDTEC Period, as appropriate.

14.18.12 For Power Stations, the short term chargeable capacity for LDTEC with positive generation tariffs referred to in Paragraph [14.18.11](#), will be the capacity purchased

Deleted: 14.18.1114.18.

either on a profiled firm<sup>2</sup> or indicative<sup>3</sup> basis and shall be assessed according to the capacity purchased on a weekly basis. The short-term chargeable capacity for LDTEC in any week may comprise of a number of increments, which shall be determined by considering LDTEC purchased previously in the Financial Year (whether or not in the same LDTEC Period). For example, if in a given week the LDTEC is 200MW but in a previous week the LDTEC had been 150MW, the short-term chargeable capacity in the latter week would comprise of two increments: one of 150MW and a second of 50MW. Further examples are provided in 14.16.6.

### Generation with negative wider tariffs

14.18.13 The Chargeable Capacity for Power Stations with negative wider generation tariffs is the average of the capped metered volumes during the three settlement periods described in [14.18.14](#) below, for the Power Station (i.e. the sum of the metered volume of each BM Unit associated with Power Station in Appendix C of its Bilateral Agreement). A Power Station should not exceed its TEC as to do so would be in breach of the CUSC, except where it is entitled to do so under the specific circumstances laid out in the CUSC (e.g. where a User has been granted Short Term Transmission Entry Capacity). If TEC is exceeded, the metered volumes would each be capped by the TEC for the Power Station applicable for that Financial Year. For the avoidance of doubt, TNUoS Charges will be determined on the TEC held by a User as specified within a relevant bilateral agreement regardless of whether or not it enters into a temporary TEC Exchange (as defined in the CUSC).

Deleted: 14.18.1414.18.

14.18.14 The three settlement periods are those of the highest metered volumes for the Power Station and the two half hour settlement periods of the next highest metered volumes which are separated from the highest metered volumes and each other by at least 10 Clear Days, between November and February of the relevant Financial Year inclusive. These settlement periods do not have to coincide with the Triad.

#### Example

If the highest TEC for a Power Station were **250MW** and the highest metered volumes and resulting capped metered volumes were as follows:

Date	19/11/08	13/12/08	06/02/09
Highest Metered Volume in month (MW)	<b>245.5</b>	<b>250.3</b>	<b>251.4</b>
Capped Metered Volume (MW)	<b>245.5</b>	<b>250.0</b>	<b>250.0</b>

Then, the chargeable Capacity for the Power Station would be:

$$\left( \frac{245.5 + 250 + 250}{3} \right) = \mathbf{248.5 \text{ MW}}$$

Note that in the example above, the Generator has exceeded its TEC on 13 December 2007 and 6 February 2008 and would therefore be in breach of the CUSC unless the

<sup>2</sup> where an LDTEC Block Offer has been accepted (Profiled Block LDTEC) and a firm profile of capacity has been purchased.

<sup>3</sup> where an LDTEC Indicative Block Offer has been accepted (Indicative Profiled Block LDTEC) and a right to future additional capacity up to a requested level has been purchased, the availability of which will be notified on a weekly basis in accordance with the CUSC.

generator had an approved STTEC or LDTEC value. (The STTEC and LDTEC charge for negative zones is currently set at zero).

14.18.15 The short-term chargeable capacity for Power Stations with negative generation tariffs is any approved STTEC or LDTEC applicable to that Power Station during a valid STTEC Period or LDTEC Period, as applicable.

14.18.16 For Power Stations with negative generation tariffs, the short-term chargeable capacity for LDTEC referred to in Paragraph 14.18.15 will be the capacity purchased either on a profiled firm or indicative basis and shall be assessed according to the capacity purchased on a weekly basis. The short-term chargeable capacity for LDTEC in any week may comprise of a number of increments, which shall be determined by considering LDTEC purchased previously in the Financial Year (whether or not in the same LDTEC Period). For example, if in a given week the LDTEC is 200MW but in a previous week the LDTEC had been 150MW, the short-term chargeable capacity in the latter week would comprise of two increments: one of 150MW and a second at 50MW.

Deleted: 14

14.18.17 As noted above, a negative LDTEC tariff in negative generation charging zones is set to zero. Accordingly no payments will be made for use of LDTEC (in any of its forms) in these zones.

### Basis of Local Generation Charges

14.18.18 The Chargeable Capacity for Power Stations will be the same as that used for wider generation charges, except that each component of the local tariff shall be considered separately as to whether it is a positive or negative tariff component. This means that where a local circuit tariff is negative, the final charging liability for this element will be based on actual metered output as described in Paragraph 14.18.13

Deleted: 12.

### Small Generators Charges

14.18.19 Eligible small generators' tariffs are subject to a discount of a designated sum defined by Licence Condition C13 as 25% of the combined residual charge for generation and demand. The calculation for small generators charges is not part of the methodology however, for information the designated sum is included in **The Statement of Use of System Charges**.

### Monthly Charges

14.18.20 Initial Transmission Network Use of System Generation Charges for each Financial Year will be based on the Power Station Transmission Entry Capacity (TEC) for each User as set out in their Bilateral Agreement. The charge is calculated as above. This annual TNUoS generation charge is split evenly over the months remaining in the year. For positive final generation tariffs, if TEC increases during the charging year, the party will be liable for the additional charge incurred for the **full** year, which will be recovered uniformly across the remaining chargeable months in the relevant charging year (subject to Paragraph 14.18.21 below). An increase in monthly charges reflecting an increase in TEC during the charging year will result in interest being charged on the differential sum of the increased and previous TEC charge. The months liable for interest will be those preceding the TEC increase from April in year t. For negative final generation tariff, any increase in TEC during the year will lead to a recalculation of the monthly charges for the remaining chargeable months of the relevant charging year. However, as TEC decreases do not become effective until the start of the financial year following approval, no recalculation is necessary in these cases. As a result, if TEC increases, monthly payments to the generator will increase accordingly.

Deleted: ..20

14.18.21 The provisions described above for increases in TEC during the charging year shall not apply where the LDTEC (in any of its forms) has been approved for use before the TEC is available, which will typically mean the LDTEC has been approved after the TEC increase has been approved. In such instances, the party shall commence payments for TEC during the LDTEC Period for LDTEC purchased up to the future level of TEC and LDTEC Charges will only apply to LDTEC that is incremental to the TEC increase. For the avoidance of doubt, where TEC has been approved after LDTEC in a given year, these provisions shall not apply and the LDTEC shall be considered additional to the TEC and charged accordingly.

### Ad hoc Charges

14.18.22 For each STTEC period successfully applied for, a charge will be calculated by multiplying the STTEC by the tariff calculated in accordance with Paragraph 14.16.3. The Company will invoice Users for the STTEC charge once the application for STTEC is approved.

Deleted: .

14.18.23 For Power Stations utilising LDTEC (in any of its forms) the LDTEC Charge for each LDTEC Period is the sum of the charging liabilities associated with each incremental level of short term chargeable capacity provided by LDTEC within the LDTEC Period (assessed on a weekly basis). The charging liability for a given incremental level of short term chargeable capacity is the sum of:

- i) the product of the higher tariff rate (calculated in accordance with Paragraph 14.16.6) and capacity purchased at this increment for the first 17 weeks in a Financial Year (whether consecutive or not); and
- ii) the product of the lower tariff rate (calculated in accordance with Paragraph 14.16.6) and capacity purchased at this increment in any additional weeks within the same Financial Year (whether consecutive or not).

14.18.24 For each LDTEC Period successfully applied for, the LDTEC Charge will be split evenly over the relevant LDTEC Period and charged on a monthly basis. LDTEC charges will apply to both LDTEC (in any of its forms) and Temporary Received TEC held by a User. For the avoidance of doubt, the charging methodology will not differentiate between access rights provided to a generator by LDTEC or through Temporary Received TEC obtained through a Temporary TEC Exchange (as defined in the CUSC).

### Example

The diagrams below show two cases where LDTEC has been purchased: in Case A, two LDTEC Periods have been purchased; and in Case B one LDTEC Period has been purchased. The total capacity purchased in both cases is the same. The top diagrams illustrate the capacity purchased, while lower diagrams illustrate the incremental levels of short term chargeable capacities of LDTEC and the tariff rate that would apply to that capacity.

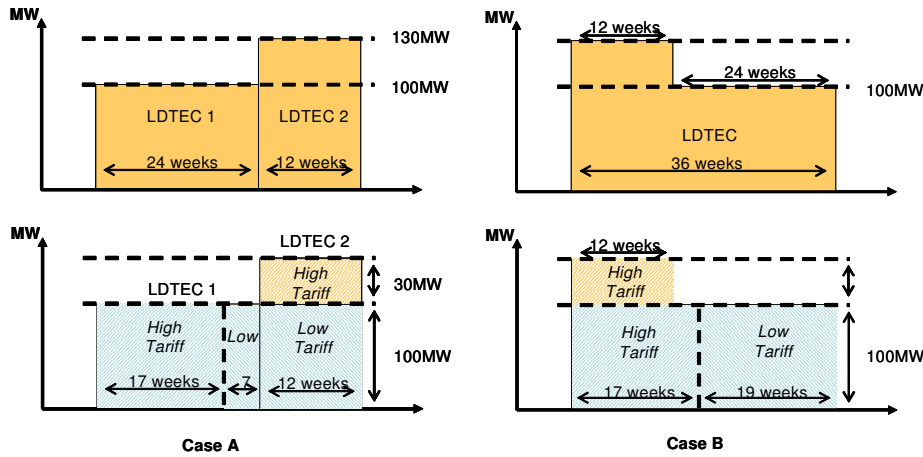

In both cases, the total amount charged for the LDTEC would be the same:

- Capacity charges at the higher tariff rate:
  - 17 weeks at the 100MW increment
  - 12 weeks at the 30MW increment
- Capacity charges at the lower tariff rate:
  - 19 weeks at the 100MW increment

**Formatted:** Indent: Left: 0 cm, Hanging: 0.44 cm, Bulleted + Level: 1 + Aligned at: 0 cm + Tab after: 0.63 cm + Indent at: 0.63 cm, Tabs: 0.44 cm, List tab + Not at 0.63 cm + 1.27 cm

**Formatted:** Indent: Left: 0 cm, Hanging: 0.47 cm, Bulleted + Level: 1 + Aligned at: 0 cm + Tab after: 0.63 cm + Indent at: 0.63 cm, Tabs: 0.47 cm, List tab + Not at 0.63 cm + 1.27 cm

### Embedded Transmission Use of System Charges “ETUoS”

- 14.18.25 The ETUoS charges are a component of Use of System charges levied on offshore generators whose offshore transmission connection is embedded in an onshore distribution network. The charge relates to the provision and use of the onshore distribution network.
- 14.18.26 The main purpose of ETUoS charges is to pass through the charges that are levied by the DNO on the NETSO to the offshore generator(s). This charge reflects the charges levied by the DNO for the costs of any works on and use of the DNO network in accordance with the DNO’s charging statements and will include, but is not limited to, upfront charges and capital contributions in respect of any works as well as the ongoing and annual Use of System charges for generation connected to the distribution network.
- 14.18.27 In the case of some relevant transitional offshore generation projects, ETUoS will also be used to pass through historic DNO capital contributions forming part of the Offshore Transmission Owner tender revenue stream.
- 14.18.28 The specific nature of the ETUoS charge and the payment profile for these will depend upon the charging arrangements of the relevant DNO and reference should be made to the relevant DNO’s charging statement. In terms of applicable transitional offshore generation projects the ETUoS payment profile will be consistent with the recovery of the Offshore Transmission Owner revenue stream.
- 14.18.29 Where a DNO’s charge relates to more than one offshore generator, the related ETUoS charge will represent a straight pass through of the distribution charge specific to each relevant offshore generator. Where specific information is not available, charges will be pro-rated based on the TEC of the relevant offshore generators connected to that offshore network.
- 14.18.30 Invoices for ETUoS charges shall be levied by the NETSO on the offshore generator as soon as reasonably practicable after invoices have been received by the NETSO for payment such that the NETSO can meet its payment obligations to the DNO. The



initial payments and payment dates will be outlined in a User's Construction Agreement and/or Bilateral Agreement.

14.18.31 As the ETUoS charges reflect the DNO charges to the NETSO, such charges will be subject to variation when varied by the DNO. Where the User disputes regarding the ETUoS charge please note that this will result in a dispute between the NETSO and DNO under the DCUSA.

### Reconciliation of Generation Charges

14.18.32 The reconciliation process is set out in the CUSC and in line with the principles set out above.

14.18.33 In the event of a manifest error in the calculation of TNUoS charges which results in a material discrepancy in a User's TNUoS charge as defined in Sections 14.17.27 to 14.17.29, the generation charges of Users qualifying under Section 14.17.28 will be reconciled in line with [14.18.20](#) and [14.18.25](#) using the recalculated tariffs.

Deleted: 14.18.2014.18.

Deleted: 14.18.2514.18.

### Further Information

14.18.34 **The Statement of Use of System Charges** contains the £/kW generation zonal tariffs for the current Financial Year.

## 14.19 Data Requirements

### Data Required for Charge Setting

- 14.19.1 Users who are Generators or Interconnector Asset Owners provide to The Company a forecast for the following Financial Year of the highest Transmission Entry Capacity (TEC) applicable to each Power Station or Interconnector for that Financial Year. For Financial Year 2008/9 Scottish Generators or Interconnector Asset Owners provide to The Company a forecast of the equivalent highest 'export' capacity figure. This data is required by The Company as the basis for setting TNUoS tariffs. The Company may request these forecasts in the November prior to the Financial Year to which they relate, in accordance with the CUSC. Additionally Users who are generators provide to The Company details of their generation plant type.
- 14.19.2 Users who are owners or operators of a User System (e.g. Distribution companies) provide a forecast for the following Financial Year of the Natural Demand attributable to each Grid Supply Point equal to the forecasts of Natural Demand under both Annual Average Cold Spell (ACS) Conditions and a forecast of the average metered Demand attributable to such Grid Supply Point for the National Grid Triad. This data is published in table 2.4 of the Seven Year Statement and is compiled from week 24 data submitted in accordance with the Grid Code.
- 14.19.3 For the following Financial Year, The Company shall use these forecasts as the basis of Transmission Network Use of System charges for such Financial Year. A description of how this data is incorporated is included in 14.15 Derivation of the Transmission Network Use of System Tariff.
- 14.19.4 If no data is received from the User, then The Company will use the best information available for the purposes of calculation of the TNUoS tariffs. This will normally be the forecasts provided for the previous Financial Year.

Deleted: u

Deleted: G

### Data Required for Calculating Users' Charges

- 14.19.5 In order for The Company to calculate Users' TNUoS charges, Users who are Suppliers shall provide to The Company forecasts of half-hourly and non-half-hourly demand in accordance with paragraph 14.17.14 and 14.17.15 and in accordance with the CUSC.

## 14.20 Applications

14.20.1 Application fees are payable in respect of applications for new Use of System agreements; modifications to existing agreements; and applications for short-term access products or services. These are based on the reasonable costs that transmission licensees incur in processing these applications.

### Applications for short-term access

14.20.2 Application fees for short-term access products or services are fixed and detailed in the **Statement of Use of System Charges**. These are non-refundable except for the following limited instances:

- Where a User (or Users) withdraw their application in accordance with any interactivity provisions that may be contained within the CUSC; or
- Where the application fee covers ongoing assessment work that is contingent on the acceptance of the offer.

14.20.3 In either case, the refunded amount will be proportional to the remaining assessment time available.

14.20.4 To ensure that application fees for short-term access are cost reflective, fees may be comprised of a number of components. For instance, the LDTEC Request Fee is comprised of a number of components and the total fee payable is the sum of those components that apply to the type(s) of LDTEC Offer(s) requested. For example:

- The LDTEC Request Fee for an LDTEC Block Offer is the basic request fee.
- The LDTEC Request Fee for an LDTEC Indicative Block Offer is the sum of the basic request fee and the additional rolling assessment fee.
- The LDTEC Request Fee payable for a combined LDTEC Block Offer and LDTEC Indicative Block Offer is the sum of the basic request fee, the additional rolling assessment fee, and the additional combined application fee.

**Formatted:** Indent: Left: 2.87 cm, Hanging: 0.75 cm, Bulleted + Level: 1 + Aligned at: 0 cm + Tab after: 0.63 cm + Indent at: 0.63 cm, Tabs: 3.62 cm, List tab + Not at 0.63 cm + 1.27 cm

**Formatted:** Indent: Left: 2.87 cm, Hanging: 0.75 cm, Bulleted + Level: 1 + Aligned at: 0 cm + Tab after: 0.63 cm + Indent at: 0.63 cm, Tabs: 3.62 cm, List tab + Not at 0.63 cm + 1.27 cm

**Formatted:** Indent: Left: 2.87 cm, Hanging: 0.75 cm, Bulleted + Level: 1 + Aligned at: 0 cm + Tab after: 0.63 cm + Indent at: 0.63 cm, Tabs: 3.62 cm, List tab + Not at 0.63 cm + 1.27 cm

### Applications for new or modified existing Use of System Agreements

14.20.5 Users can opt to pay a fixed price application fee in respect of their application or pay the actual costs incurred. The fixed price fees for applications are detailed in the **Statement of Use of System Charges**.

14.20.6 If a User chooses not to pay the fixed fee, the application fee will be based on an advance of transmission licensees' Engineering and out-of pocket expenses and will vary according to the size of the scheme and the amount of work involved. Once the associated offer has been signed or lapsed, a reconciliation will be undertaken. Where actual expenses exceed the advance, The Company will issue an invoice for the excess. Conversely, where The Company does not use the whole of the advance, the balance will be returned to the User.

14.20.7 The Company will refund the first application fee paid (the fixed fee or the amount post-reconciliation) and consent payments made under the Construction Agreement for new or modified existing agreements. The refund shall be made either on commissioning or against the charges payable in the first three years of the new or modified agreement. The refund will be net of external costs.

- 14.20.8 The Company will not refund application fees for applications to modify a new agreement or modified existing agreement at the User's request before any charges become payable. For example, The Company will not refund an application fee to delay the provision of a new connection if this is made prior to charges becoming payable.

## 14.21 Transport Model Example

For the purposes of the DCLF Transport algorithm, it has been assumed that the value of circuit impedance is equal to the value of circuit reactance.

Consider the following 3-node network, where generation at node A is intermittent and generation at node B is conventional:

Deleted: ¶

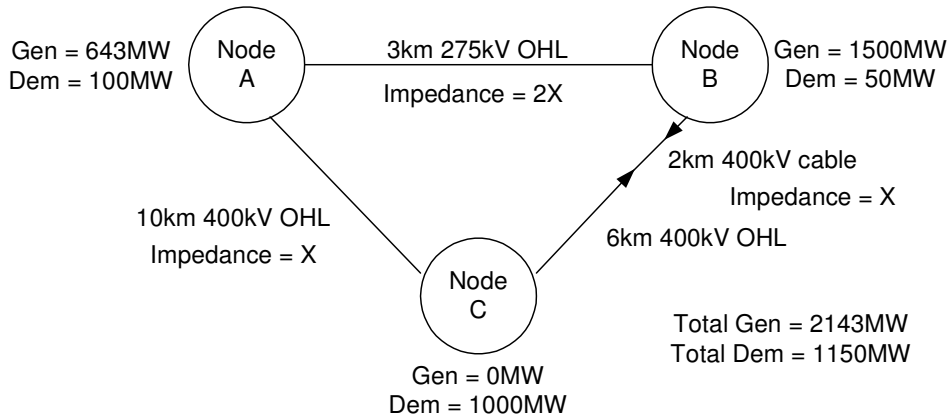

→ Denotes cable

For both Peak Security and Year Round generation backgrounds, the nodal generation is scaled according to the relevant Scaling Factors as set out in the Security Standard, such that total system generation equals total system demand.

Deleted: The first step is to match total demand

Deleted: total

Deleted: by scaling uniformly

Deleted: down

Deleted:

### Peak Security background:

A fixed scaling factor of 0% is applied to intermittent generation at node A and a variable scaling factor is applied to the conventional generation at node B so that the total generation is equal to the total demand.

Node A Generation =  $0 * 643\text{MW} = 0\text{MW}$

Deleted:  $1150/1495 * 650\text{MW} = 500\text{MW}$ ¶

Node B Generation =  $1150/1500 * 1500\text{MW} = 1150\text{MW}$

Deleted:  $1495 * 845\text{MW} = 650\text{MW}$ ¶

This gives the following balanced system, where the actual generation after the application of scaling factors is shown:

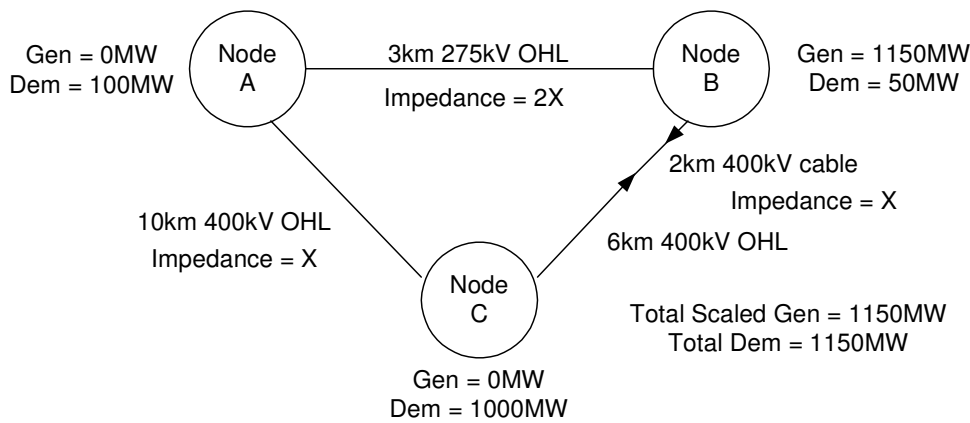

Assuming Node A is the reference node<sup>†</sup>, each 400kV circuit has impedance X, the 275kV circuit has impedance 2X, the 400kV cable circuit expansion factor is 10 and the 275kV overhead line circuit expansion factor is 2, the DCLF transport algorithm calculates the base case power flows for Peak Security background as follows:

Deleted: ¶  
¶  
¶  
¶

Formatted: Font: Times New Roman, 12 pt

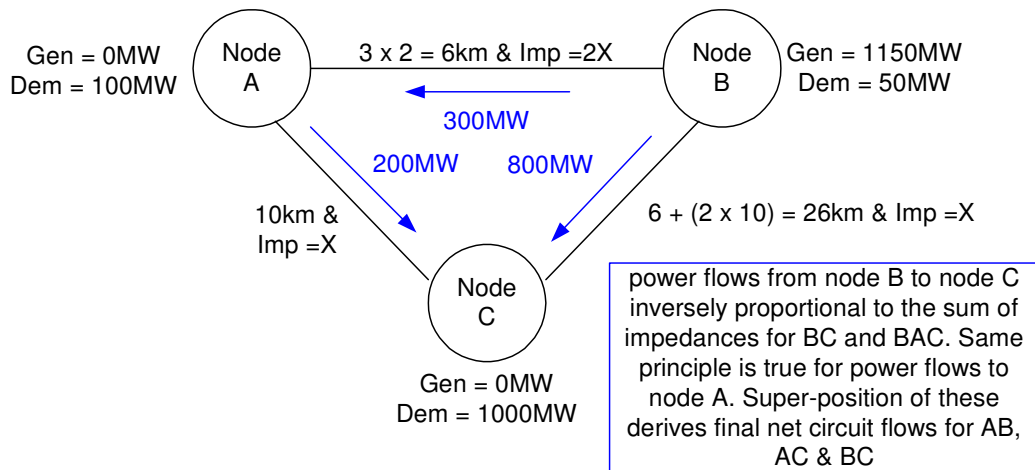

power flows from node B to node C inversely proportional to the sum of impedances for BC and BAC. Same principle is true for power flows to node A. Super-position of these derives final net circuit flows for AB, AC & BC

Node B exports, whilst Nodes A and C import. Hence the DCLF algorithm derives flows to deliver export power from Node B to meet import needs at Nodes A and C.

Step 1: Net export from Node B to Node A is 100MW; both routes BA and BC-CA have impedance 2X; hence 50MW would flow down both routes.

Step 2: Net export from Node B to Node C is 1000MW; route BC has impedance X and route BA-AC has impedance 3X; hence 750MW would flow down BC and 250MW along BA-AC

Step 3: Using super-position to add the flows derived in Steps 1 and 2 derives the following;

Flow AC	=	-50MW + 250MW	=	200MW
Flow AB	=	-50MW - 250MW	=	-300MW
Flow BC	=	50MW + 750MW	=	800MW

† For simplicity, fixed reference node has been used instead of a distributed reference node.

**Year Round background:**

A fixed scaling factor of 70% is applied to intermittent generation at node A and a variable scaling factor is applied to the conventional generation at node B so that the total generation is equal to the total demand.

Node A Generation = 70% \* 643MW = 450MW

Node B Generation = (1150-450)/1500 \* 1500MW = 700MW

This gives the following balanced system, where the actual generation after the application of scaling factors is shown:

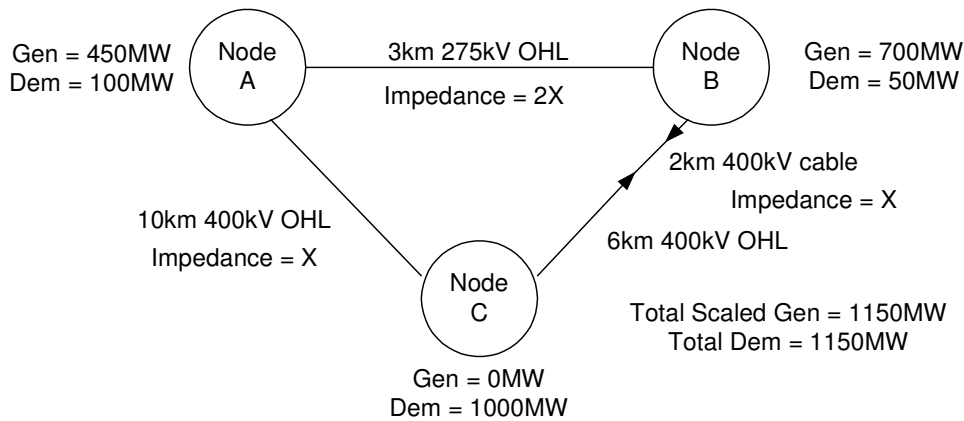

Assuming the same circuit impedances and expansion factors as used above in the Peak Security background, the DCLF transport algorithm calculates the base case power flows for Year Round background as follows:

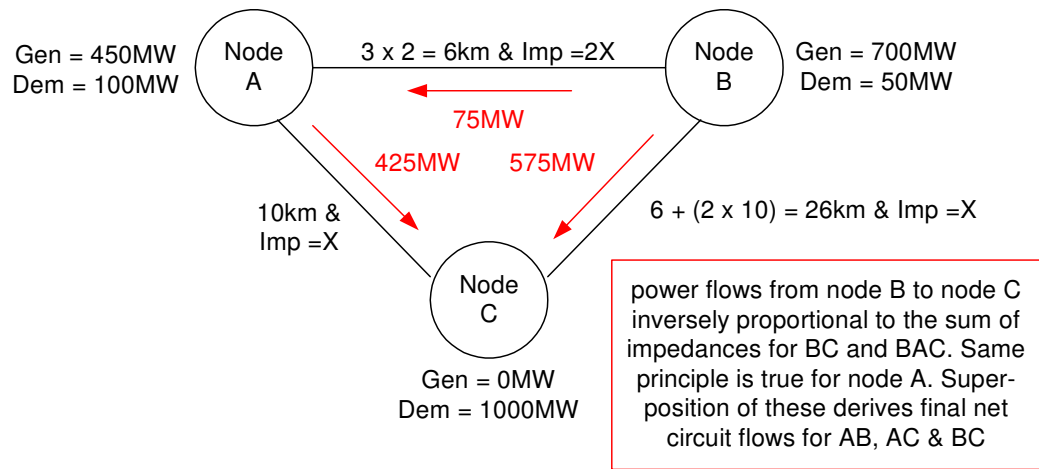

Nodes A and B export, whilst Node C imports. Hence the DCLF algorithm derives flows to deliver export power from Nodes A and B to meet import needs at Node C.

Step 1: Net export from Node A is 350MW; route AC has impedance X and route AB-BC has impedance 3X; hence 262.5MW would flow down AC and 87.5MW along AB-BC.

- Formatted: Font: Arial
- Formatted: Body Text 2, Justified
- Deleted: 400MW
- Deleted: 300MW
- Deleted: 100MW

Step 2: Net export from Node B is 650MW; route BC has impedance X and route BA-AC has impedance 3X; hence 487.5MW would flow down BC and 162.5MW along BA-AC

~~Deleted: 600MW~~  
~~Deleted: 450MW~~  
~~Deleted: 150MW~~

Step 3: Using super-position to add the flows derived in Steps 1 and 2 derives the following;

Flow AC =  $\underline{262.5MW + 162.5MW = 425MW}$   
 Flow AB =  $\underline{87.5MW - 162.5MW = -75MW}$   
 Flow BC =  $\underline{87.5MW + 487.5MW = 575MW}$

~~Deleted: 300MW + 150MW = . 450MW¶~~  
~~Deleted: 100MW - 150MW = . -50MW¶~~  
~~Deleted: 100MW + 450MW = . 550MW¶~~

Then, based on the background giving rise to highest flow, each circuit is tagged as either Peak Security or Year Round.

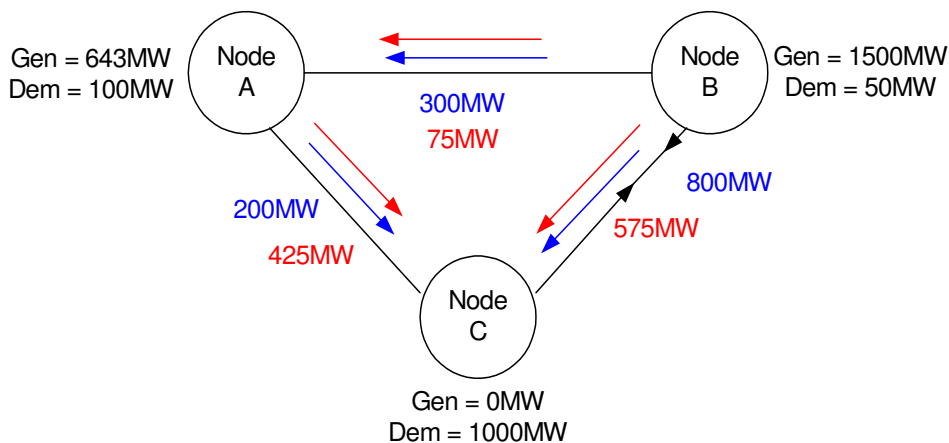

Therefore, circuits AB and BC are tagged as Peak Security and AC is tagged as Year Round.

Total Peak Security cost =  $(300 \times 6) + (800 \times 26) = \underline{22,600}$  MWkm (base case)

~~Formatted: Font: 11 pt~~  
~~Deleted: 450 x 10) + (50 x~~  
~~Formatted: Font: 11 pt~~  
~~Deleted: 550 x~~  
~~Formatted: Font: 11 pt~~  
~~Deleted: 19,100~~  
~~Formatted: Font: 11 pt~~  
~~Formatted: Font: 11 pt~~  
~~Formatted: Font: 11 pt~~  
~~Deleted: 1~~  
~~Deleted: in cost~~  
~~Deleted: . This is demonstrated as follows:¶~~  
~~Deleted: :~~

Total Year Round cost =  $425 \times 10 = 4,250$  MWkm (base case).

We then 'inject' one MW of generation at each node with a corresponding 1MW offtake (demand) at the reference node and recalculate the total Peak Security MWkm cost and Year Round MWkm cost (noting that each circuit is only in one background). The difference from the base case for Peak Security and Year Round costs is the marginal km or shadow cost for Peak Security and Year Round networks respectively. The size and direction of the incremental one MW is shown below along with the resultant when superimposed on the relevant base case flow (i.e. higher of the Peak Security and Year Round) depicted in brackets.



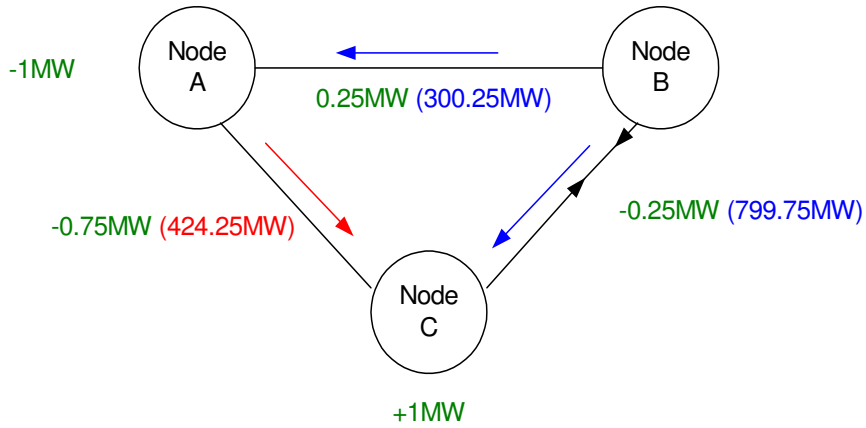

To calculate the relevant Peak Security and Year Round marginal km for node C:

Total Peak Security Cost =  $(300.25 \times 6) + (799.75 \times 26) = 22,595 \text{ MWkm}$

Total Year Round Cost =  $424.25 \times 10 = 4,242.5 \text{ MWkm}$

Marginal Peak Security cost = Incremental total Peak Security cost – Base case total Peak Security cost  
 $= 22595 - 22600 = -5 \text{ MWkm}$

Marginal Year Round cost = Incremental total Year Round cost – Base case total Year Round cost  
 $= 4242.5 - 4250 = -7.5 \text{ MWkm}$

Thus, the overall cost has reduced by 5 for Peak Security (i.e. the Peak Security marginal km = -5) and by 7.5 for Year Round (i.e. the Year Round marginal km = -7.5).

Deleted: ¶  
 Deleted: at  
 Deleted:  $449.25 \times 10) + (50$   
 Deleted: 549  
 Deleted: 19,087

Deleted: 12.  
 Deleted: 12.5).¶

## 14.22 Example: Calculation of Zonal Generation Tariffs and Charges

Deleted: .....

### Wider

Let us consider all nodes in a generation zone in this example

Deleted: 4: Western Highland.

The table below shows a sample output of the transport model comprising the node, the Peak Security wider nodal marginal km and Year Round wider nodal marginal km (observed on non-local assets) of an injection at the node with a consequent withdrawal across distributed reference node, the generation sited at the node, scaled to ensure total national generation equals total national demand, for both Peak Security and Year Round generation backgrounds.

Deleted: at the

Deleted: ¶ Genzone ... [27]

Gen Zone	Node	Wider Nodal Marginal km (Peak Security)	Scaled Generation (Peak Security)	Wider Nodal Marginal km (Year Round)	Scaled Generation (Year Round)
4	ABNE10	5.73	0.00	459.90	0.00
4	CLAY1S	239.67	0.00	306.47	0.00
4	CLUN1S	46.41	22.90	502.16	18.76
4	COUA10	45.39	0.00	423.30	0.00
4	DYCE1Q	162.70	0.00	357.81	0.00
4	ERRO10	46.82	56.13	534.03	45.99
4	FIDD1B	91.88	0.00	220.59	0.00
4	FINL1Q	79.69	12.35	495.63	10.12
4	GRIF1S	33.31	0.00	521.16	71.40
4	KIIN10	79.69	0.00	495.63	0.00
4	LOCH10	79.69	35.18	495.63	28.82
4	MILC10	117.69	0.00	328.86	0.00
4	PERS20	266.00	0.00	384.05	0.00
4	TUMB1Q	46.82	0.00	536.27	0.00
	<b>Totals</b>		<b>126.56</b>		<b>175.09</b>

In order to calculate the generation tariff we would carry out the following steps.

- (i) calculate the generation weighted wider nodal shadow costs.

For this example zone, this would be as follows:

Deleted: 4

Deleted: Genzone ... [28]

Deleted: <sp>

Deleted: ¶

sum the generation weighted wider nodal shadow cost to give a zonal figure. ¶

Gen Zone	Node	Wider Nodal Marginal km (Peak Security)	Scaled Generation (Peak Security) (MW)	Gen Weighted Wider Nodal Marginal km (Peak Security)	Wider Nodal Marginal km (Year Round)	Scaled Generation (Year Round) (MW)
4	CLUN1S	46.41	22.90	8.39	502.16	18.76
4	ERRO10	46.82	56.13	20.76	534.03	45.99
4	FINL1Q	79.69	12.35	7.77	495.63	10.12
4	GRIF1S	N/A	N/A	N/A	521.16	71.40
4	LOCH10	79.69	35.18	22.15	495.63	28.82
	<b>Totals</b>		<b>126.56</b>			<b>175.09</b>

i.e.  $79.69 \times 35.18$   
126.56

(ii) sum the generation weighted wider nodal shadow costs to give Peak Security and Year Round zonal figures.

For this example zone, this would be:

Peak Security: (8.39 + 20.76 + 7.77 + 22.15) km = 59.07 km

Year Round: (53.80 + 140.27 + 28.65 + 212.52 + 81.58) km = 516.82 km

(iii) calculate the initial Peak Security wider transport tariff and Year Round wider transport tariff by multiplying the figures in (ii) above by the expansion constant (& dividing by 1000 to put into units of £/kW) and the locational security factor.

For this example zone, and assuming an expansion constant of £10.07/MWkm and a locational security factor of 1.8:

a) Initial Peak Security wider tariff -

$$\frac{59.07 \text{ km} * \text{£}10.07/\text{MWkm} * 1.8}{1000} = \text{£}1.071/\text{kW}$$

b) Initial Year Round wider tariff -

$$\frac{516.82 \text{ km} * \text{£}10.07/\text{MWkm} * 1.8}{1000} = \text{£}9.368/\text{kW}$$

**Local**

(iv) If we assume (for the sake of this example) that the generator connecting at CLUN1S is a thermal plant with a Peak Security flag of 1 and an Annual Load Factor (ALF) of 60%, which connects via 10km of 132kV 100MVA rated single circuit overhead line from the nearest MITS node, with no redundancy, the substation is rated at less than 1320MW, and there is no other generation or demand connecting to this circuit, then:

a) referencing the table in paragraph 14.15.94 the local substation tariff will be £0.133/kW; and

b) running the transport model with a local circuit expansion factor of 10.0 applied to the 10km of overhead line connecting CLUN1S to the nearest MITS node and the wider circuit expansion factors applied to all other circuits, gives a local nodal marginal cost of 100MWkm. This is the additional MWkm costs associated with the node's local assets. Applying the expansion constant of £10.07/MWkm and local security factor of 1.0 and dividing by 1000 gives a local circuit tariff of £1.007/kW.

**Residual**

(v) We now need to calculate the residual tariff. This is calculated by taking the total revenue to be recovered from generation (calculated as c.27% of total The Company TNUoS target revenue for the year) less the revenue which would be recovered through the generation transport tariffs divided by total expected generation.

Assuming the total revenue to be recovered from TNUoS is £1067m, the total recovery from generation would be (27% x £1067m) = £288m. Assuming the total recovery from both wider generation transport tariffs (i.e. wider Peak Security tariff and wider Year Round tariff) and local generation tariffs (i.e. local substation tariff and local circuit tariff) is £70m and total forecast chargeable generation capacity is 67000MW, the Generation residual tariff would be as follows:

Deleted: 4

Deleted: (366.48+ 261.75 +290.71 + 108.

Deleted: + 100.67

Deleted: 1127.81km¶  
¶  
¶ modify the zonal figure in (ii) above by the generation/demand split correction factor. This ensures that the 27:73 (approx) split of revenue recovery between generation and demand is retained.¶  
¶ For zone 4 this would be say:¶  
¶ . . 1127.81km + (-239.60

Formatted: Font: 11 pt, Bold, Underline, Check spelling and grammar

Deleted: ) = 888.21

Formatted: Font: Not Bold, No underline

Formatted: Indent: Left: 0 cm

Deleted: <sp>

Deleted: ¶  
¶  
¶  
¶  
¶

Deleted: ¶  
¶  
¶

Deleted: figure

Deleted: i

Deleted: 4

Deleted: 888.21

Formatted: Indent: Left: 0.63 cm

Deleted: 6.10

Deleted: .

Formatted: Indent: Left: 0 cm

Deleted: generation

Deleted: CEAN1Q

Deleted: 67,

Deleted: CEAN1Q

$$\frac{\pounds 288 - \pounds 70m}{65000MW} = \underline{\pounds 3.35/kW}$$

(vi) Therefore the charges for thermal plant with a TEC of 100MW and an ALF of 60%, connecting at CLUN1S is:

- = Wider Peak Security Tariff \* PS Flag \* TEC
- = Wider Year Round Tariff \* ALF \* TEC
- = Local substation Tariff \* TEC
- = Local circuit Tariff \* TEC
- = Residual Tariff \* TEC

For this example, the above charges are –

- = 1.071 \* 1 \* 100,000
- = 9.368 \* 0.6 \* 100,000
- = 0.133 \* 100,000
- = 1.007 \* 100,000
- = 3.35 \* 100,000

(effectively,  $\pounds 11.182/kW * 100,000kW = \pounds 1,118,200$ )

(vii) Alternatively, if we assume that the generator connecting at CLUN1S is an intermittent wind generation plant (instead of a thermal plant) with a TEC of 100MW, PS Flag of 0 and an ALF of 30%, then the charges payable will be –

- = 1.071 \* 0 \* 100,000
- = 9.368 \* 0.3 \* 100,000
- = 0.133 \* 100,000
- = 1.007 \* 100,000
- = 3.35 \* 100,000

(effectively,  $\pounds 7.30/kW * 100,000kW = \pounds 730,000$ )

**Formatted:** Centered

**Deleted:** to get to

**Deleted:** final tariff

**Deleted:** generator

**Deleted:** a particular node, we simply sum the generation residual tariff calculated in (vi), the wider zonal transport tariff calculated in (iv), the local substation tariff calculated in (v(a)), and the local circuit tariff calculated in (v(b)). In

**Deleted:** ¶

**Deleted:** ¶  
- For CEAN1Q : . £16.10/kW + £3.35/kW + £

**Formatted:** Font color: Auto, English (U.K.), Do not check spelling or grammar

**Deleted:** 135/kW + £

**Formatted:** Left, Indent: Left: 0.25 cm

**Formatted:** English (U.K.)

**Deleted:** /kW = £20.592 /kW

**Formatted:** English (U.K.)

**Deleted:** ¶  
To summarise, in order to calculate the generation tariffs, we evaluate a generation weighted zonal marginal km cost, modify by a re-referencing quantity to ensure that our revenue recovery split between generation and demand is correct, multiply by the security factor, then we add a constant (termed the residual cost) to give the overall tariff.¶  
-----Page Break-----  
¶

## 14.23 Example: Calculation of Zonal Demand Tariff

Let us consider all nodes in a demand zone in this example.

Deleted: 14: South Western

The table below shows a sample output of the transport model comprising the node, the Peak Security and Year Round marginal km of an injection at the node with a consequent withdrawal at the distributed reference node, the generation sited at the node, scaled to ensure total national generation = total national demand and the demand sited at the node.

Deleted: ¶

Deleted: ¶  
Demand Zone

... [29]

<u>Demand Zone</u>	<u>Node</u>	<u>Peak Security Nodal Marginal</u> km	<u>Year Round Nodal Marginal</u> km	<u>Demand (MW)</u>
14	ABHA4A	-77.25	-230.25	127
14	ABHA4B	-77.27	-230.12	127
14	ALVE4A	-82.28	-197.18	100
14	ALVE4B	-82.28	-197.15	100
14	AXMI40 SWEB	-125.58	-176.19	97
14	BRWA2A	-46.55	-182.68	96
14	BRWA2B	-46.55	-181.12	96
14	EXET40	-87.69	-164.42	340
14	HINP20	-46.55	-147.14	0
14	HINP40	-46.55	-147.14	0
14	INDQ40	-102.02	-262.50	444
14	IROA20 SWEB	-109.05	-141.92	462
14	LAND40	-62.54	-246.16	262
14	MELK40 SWEB	18.67	-140.75	83
14	SEAB40	65.33	-140.97	304
14	TAUN4A	-66.65	-149.11	55
14	TAUN4B	-66.66	-149.11	55
	<b>Totals</b>			<b>2748</b>

In order to calculate the demand tariff we would carry out the following steps:

- (i) calculate the demand weighted nodal shadow costs

For this example zone this would be as follows:

<u>Demand zone</u>	<u>Node</u>	<u>Peak Security Nodal Marginal km</u>	<u>Year Round Nodal Marginal km</u>	<u>Demand (MW)</u>	<u>Peak Security Demand Weighted Nodal Marginal km</u>	<u>Year Round Demand Weighted Nodal Marginal km</u>
14	ABHA4A	-77.25	-230.25	127	-3.57	-10.64
14	ABHA4B	-77.27	-230.12	127	-3.57	-10.64
14	ALVE4A	-82.28	-197.18	100	-2.99	-7.17
14	ALVE4B	-82.28	-197.15	100	-2.99	-7.17
14	AXMI40 SWEB	-125.58	-176.19	97	-4.43	-6.22
14	BRWA2A	-46.55	-182.68	96	-1.63	-6.38
14	BRWA2B	-46.55	-181.12	96	-1.63	-6.33
14	EXET40	-87.69	-164.42	340	-10.85	-20.34
14	INDQ40	-102.02	-262.50	444	-16.48	-42.41
14	IROA20 SWEB	-109.05	-141.92	462	-18.33	-23.86
14	LAND40	-62.54	-246.16	262	-5.96	-23.47
14	MELK40 SWEB	18.67	-140.75	83	0.56	-4.25
14	SEAB40	65.33	-140.97	304	7.23	-15.59
14	TAUN4A	-66.65	-149.11	55	-1.33	-2.98
14	TAUN4B	-66.66	-149.11	55	-1.33	-2.98
	<b>Totals</b>			<b>2748</b>	<b>-49.19</b>	<b>-190.43</b>

**Comment [g1]:** Why do we delete the reference in 14.22 to a specific zone (4) but have one here (14)?

**Deleted:** 14

**Deleted:** Demand zone (... [30])

**Deleted:** <sp>

**Deleted:** 287.99km - (-239.60km) = **527.59 km**¶

- (ii) sum the Peak Security and Year Round demand weighted nodal shadow costs to give zonal figures. For zone 14 this is shown in the above table and is 49.19km for Peak Security background and 190.43km for Year Round background.
- (iii) calculate the transport tariffs by multiplying the figures in (ii) above by the expansion constant and the locational security factor (& dividing by 1000 to put into units of £/kW):

For this example zone, assuming an expansion constant of £10.07/MWkm and a locational security factor of 1.80:

**Deleted:** 14

a) Peak Security tariff -  

$$\frac{49.19\text{km} * \text{£}10.07/\text{MWkm} * 1.8}{1000} = \text{£}0.89/\text{kW}$$

b) Year Round tariff -  

$$\frac{190.43\text{km} * \text{£}10.07/\text{MWkm} * 1.8}{1000} = \text{£}3.45/\text{kW}$$

**Deleted:** -527.59km

**Deleted:** 9.56

**Deleted:** .

- (iv) We now need to calculate the residual tariff. This is calculated by taking the total revenue to be recovered from demand (calculated as c.73% of total The Company TNUoS target revenue for the year) less the revenue which would be recovered through the demand transport tariffs divided by total expected demand.

Assuming the total revenue to be recovered from TNUoS is £1067m, the total recovery from demand would be (73% x £1067m) = £779m. Assuming the total recovery from

demand transport tariffs is £130m and total forecast chargeable demand capacity is 50000MW, the demand residual tariff would be as follows:

$$\frac{£779m - £130m}{50000MW} = \underline{£12.98/kW}$$

(v) to get to the final tariff, we simply add on the demand residual tariff calculated in (iv) to the zonal transport tariffs calculated in (iii(a) and (iii(b))

For this example zone;

$$\underline{£0.89/kW} + \underline{£3.45/kW} + \underline{£12.98/kW} = \underline{£17.32/kW}$$

To summarise, in order to calculate the demand tariffs, we evaluate a demand weighted zonal marginal km costs, multiply by the expansion constant and locational security factor, then we add a constant (termed the residual cost) to give the overall tariff.

(vi) The final demand tariff is subject to further adjustment to allow for the minimum £0/kW demand charge. The application of a discount for small generators pursuant to Licence Condition C13 will also affect the final demand tariff.

- Deleted: tariff
- Deleted: iv)
- Deleted: 14
- Formatted: English (U.K.)
- Deleted: £9.56
- Deleted: 22.54
- Formatted: English (U.K.)
- Formatted: English (U.K.)
- Deleted: , modify
- Deleted: a re-referencing quantity to ensure that our revenue recovery split between generation and demand is correct
- Deleted: i
- Formatted: Check spelling and grammar
- Deleted: ¶
- Formatted: Normal, Indent: Left: 0 cm, First line: 0 cm

- Formatted: Font: Times New Roman, 12 pt
- Formatted: Normal, Indent: Left: 0 cm, First line: 0 cm



**14.24 Diagrams: Illustrative local transmission networks connected to the main NETS via single transmission circuits**

**Formatted:** Font: Arial, Font color: Dark Blue

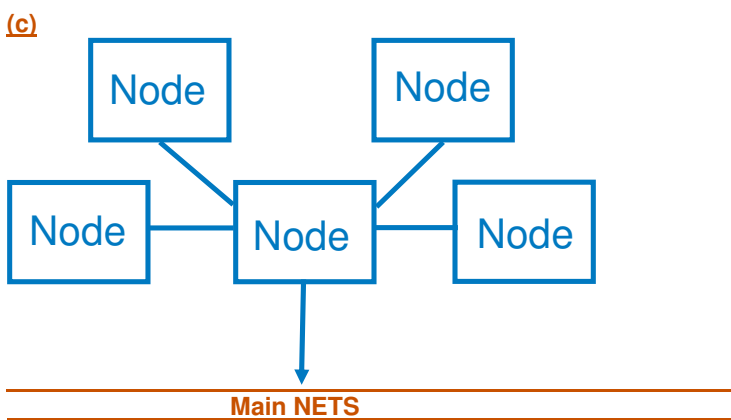
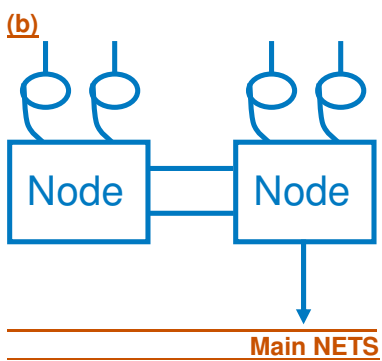
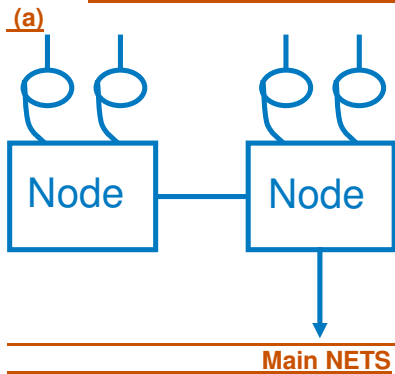

All nodes in the above illustrative transmission networks are not classified for the purposes of charging only, as MITS nodes. The diagrams above are for guidance only and may not represent the full range of layouts not classified for the purposes of charging, as MITS nodes.

**Formatted:** Left

**Deleted:** illustrative and not

**Deleted:** definitive in nature

## 14.25 Reconciliation of Demand Related Transmission Network Use of System Charges

Deleted: 4

This appendix illustrates the methodology used by The Company in the reconciliation of Transmission Network Use of System charges for demand. The example highlights the different stages of the calculations from the monthly invoiced amounts, right through to Final Reconciliation.

### Monthly Charges

Suppliers provide half-hourly (HH) and non-half-hourly (NHH) demand forecasts by BM Unit every quarter. An example of such forecasts and the corresponding monthly invoiced amounts, based on tariffs of £10.00/kW and 1.20p/kWh, is as follows:

	Forecast HH Triad Demand $HHD_F(kW)$	HH Monthly Invoiced Amount (£)	Forecast NHH Energy Consumption $NHHC_F(kWh)$	NHH Monthly Invoiced Amount (£)	Net Monthly Invoiced Amount (£)
Apr	12,000	10,000	15,000,000	15,000	25,000
May	12,000	10,000	15,000,000	15,000	25,000
Jun	12,000	10,000	15,000,000	15,000	25,000
Jul	12,000	10,000	18,000,000	19,000	29,000
Aug	12,000	10,000	18,000,000	19,000	29,000
Sep	12,000	10,000	18,000,000	19,000	29,000
Oct	12,000	10,000	18,000,000	19,000	29,000
Nov	12,000	10,000	18,000,000	19,000	29,000
Dec	12,000	10,000	18,000,000	19,000	29,000
Jan	7,200	(6,000)	18,000,000	19,000	13,000
Feb	7,200	(6,000)	18,000,000	19,000	13,000
Mar	7,200	(6,000)	18,000,000	19,000	13,000
Total		72,000		216,000	288,000

As shown, for the first nine months the Supplier provided a 12,000kW HH triad demand forecast, and hence paid HH monthly charges of £10,000  $((12,000kW \times £10.00/kW)/12)$  for that BM Unit. In January the Supplier provided a revised forecast of 7,200kW, implying a forecast annual charge reduced to £72,000  $(7,200kW \times £10.00/kW)$ . The Supplier had already paid £90,000, so the excess of £18,000 was credited back to the supplier in three £6,000 instalments over the last three months of the year.

The Supplier also initially provided a 15,000,000kWh NHH energy consumption forecast, and hence paid NHH monthly charges of £15,000  $((15,000,000kWh \times 1.2p/kWh)/12)$  for that BM Unit. In July the Supplier provided a revised forecast of 18,000,000kWh, implying a forecast annual charge increased to £216,000  $(18,000,000kWh \times 1.2p/kWh)$ . The Supplier had already paid £45,000, so the remaining £171,000 was split into payments of £19,000 for the last nine months of the year.

The right hand column shows the net monthly charges for the BM Unit.

### Initial Reconciliation (Part 1)

The Supplier's outturn HH triad demand, based on initial settlement data (and therefore subject to change in subsequent settlement runs), was 9,000kW. The HH triad demand reconciliation charge is therefore calculated as follows:

$$\text{HHD Reconciliation Charge} = (\text{HHD}_A - \text{HHD}_F) \times \text{£/kW Tariff}$$

$$= (9,000\text{kW} - 7,200\text{kW}) \times \text{£}10.00/\text{kW}$$

$$= 1,800\text{kW} \times \text{£}10.00/\text{kW}$$

$$= \text{£}18,000$$

**Formatted:** Font: Not Bold, Font color: Auto

**Formatted:** English (U.K.)

**Formatted:** Font: Not Bold, Font color: Auto, English (U.K.)

**Formatted:** Font: Not Bold, Font color: Auto

**Formatted:** English (U.K.)

To calculate monthly interest charges, the outturn HHD charge is split equally over the 12-month period. The monthly reconciliation amount is the monthly outturn HHD charge less the HH monthly invoiced amount. Interest payments are calculated based on these monthly reconciliation amounts using Barclays Base Rate.

Please note that payments made to BM Units with a net export over the Triad, based on initial settlement data, will also be reconciled at this stage.

As monthly payments will not be made on the basis of a negative forecast, the HHD Reconciliation Charge for an exporting BM Unit will represent the full actual payment owed to that BM Unit (subject to adjustment by subsequent settlement runs). Interest will be calculated as described above.

### Initial Reconciliation (Part 2)

The Supplier's outturn NHH energy consumption, based on initial settlement data, was 17,000,000kWh. The NHH energy consumption reconciliation charge is therefore calculated as follows:

$$\text{NHH Reconciliation Charge} = \frac{(\text{NHH}_A - \text{NHH}_F)}{100} \times \text{p/kWh Tariff}$$

$$= \frac{(17,000,000\text{kWh} - 18,000,000\text{kWh})}{100} \times 1.20\text{p/kWh}$$

$$= \frac{-1,000,000\text{kWh}}{100} \times 1.20\text{p/kWh}$$

$$= \text{-£}12,000$$

**Formatted:** Font: Not Bold, Font color: Auto

**Formatted:** Font: Not Bold, Font color: Auto

**Formatted:** Font: Not Bold, Font color: Auto

[worked example 4.xls - Initial!J104](#)

The monthly reconciliation amount is equal to the outturn energy consumption charge for that month less the NHH monthly invoiced amount. Interest payments are calculated based on the monthly reconciliation amounts using Barclays Base Rate.

The net initial TNUoS demand reconciliation charge is therefore £6,000 (£18,000 - £12,000).

### Final Reconciliation

Finally, let us now suppose that after all final Settlement data has been received (up to 14 months after the relevant dates), the outturn HH triad demand and NHH energy consumption values were 9,500kW and 16,500,000kWh, respectively.

$$\begin{aligned} \text{Final HH Reconciliation Charge} &= (9,500\text{kW} - 9,000\text{kW}) \times \text{£}10.00/\text{kW} \\ &= \text{£}5,000 \end{aligned}$$

$$\begin{aligned} \text{Final NHH Reconciliation Charge} &= \frac{(16,700,000\text{kWh} - 17,000,000\text{kWh}) \times 1.20\text{p}/\text{kWh}}{100} \\ &= -\text{£}3,600 \end{aligned}$$

Consequently, the net final TNUoS demand reconciliation charge will be £1,400.

Interest payments are calculated based on the monthly reconciliation amounts using Barclays Base Rate.

Outturn data for BM Units with a net export over the Triad will be received at this stage and final reconciliation will be carried out, as required. Interest will be calculated as described above.

### Terminology:

**HHD<sub>A</sub>** = The Supplier's outturn half-hourly metered Triad Demand (kW) for the demand zone concerned.

**HHD<sub>F</sub>** = The Supplier's forecast half-hourly metered Triad Demand (kW) for the demand zone concerned.

**NHHC<sub>A</sub>** = The Supplier's outturn non-half-hourly metered daily Energy Consumption (kWh) for the period 16:00 hrs to 19:00 hrs inclusive (i.e. settlement periods 33 to 38) from April 1<sup>st</sup> to March 31<sup>st</sup>, for the demand zone concerned.

**NHHC<sub>F</sub>** = The Supplier's forecast non-half-hourly metered daily Energy Consumption (kWh) for the period 16:00 hrs to 19:00 hrs inclusive (i.e. settlement periods 33 to 38) from April 1<sup>st</sup> to March 31<sup>st</sup>, for the demand zone concerned.

**£/kW Tariff** = The £/kW Demand Tariff as shown in Schedule 1 of **The Statement of Use of System Charges** for the demand zone concerned.

**p/kWh Tariff** = The Energy Consumption Tariff shown in Schedule 1 of **The Statement of Use of System Charges** for the demand zone concerned.

## 14.26 Classification of parties for charging purposes

Deleted: 25

In the event of any conflict between this Appendix and the main text within this Statement, the main text within the Statement shall take precedence.

In the following diagrams, the parties liable for Transmission Network Use of System charges are outlined in red.

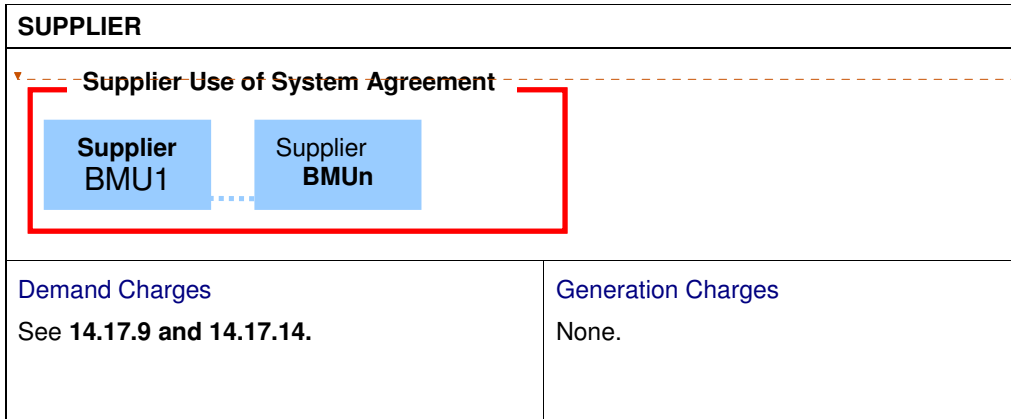

Deleted: ¶

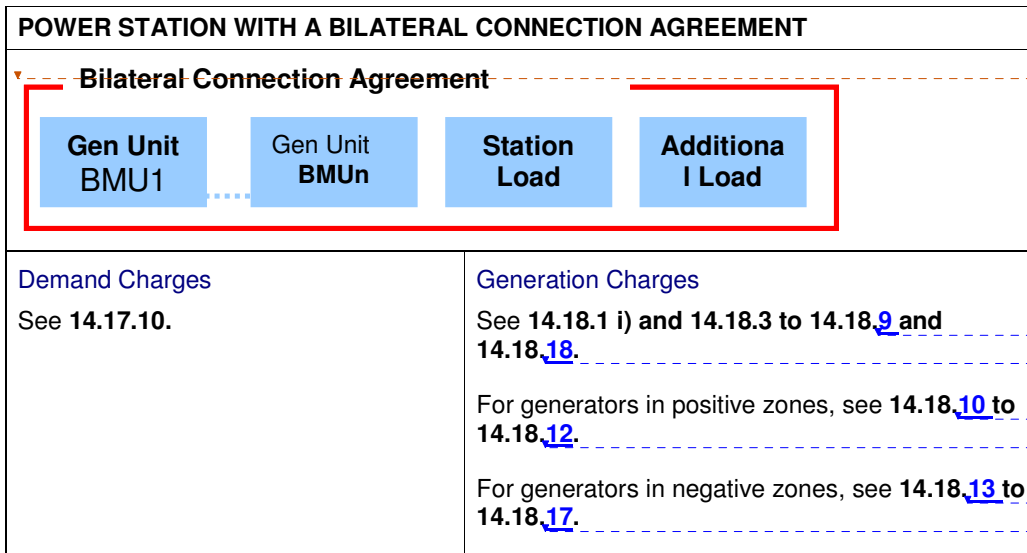

Deleted: ¶

¶  
¶  
¶  
¶

Deleted: 8

Deleted: 17

Deleted: 9

Deleted: 11

Deleted: 12

Deleted: 16

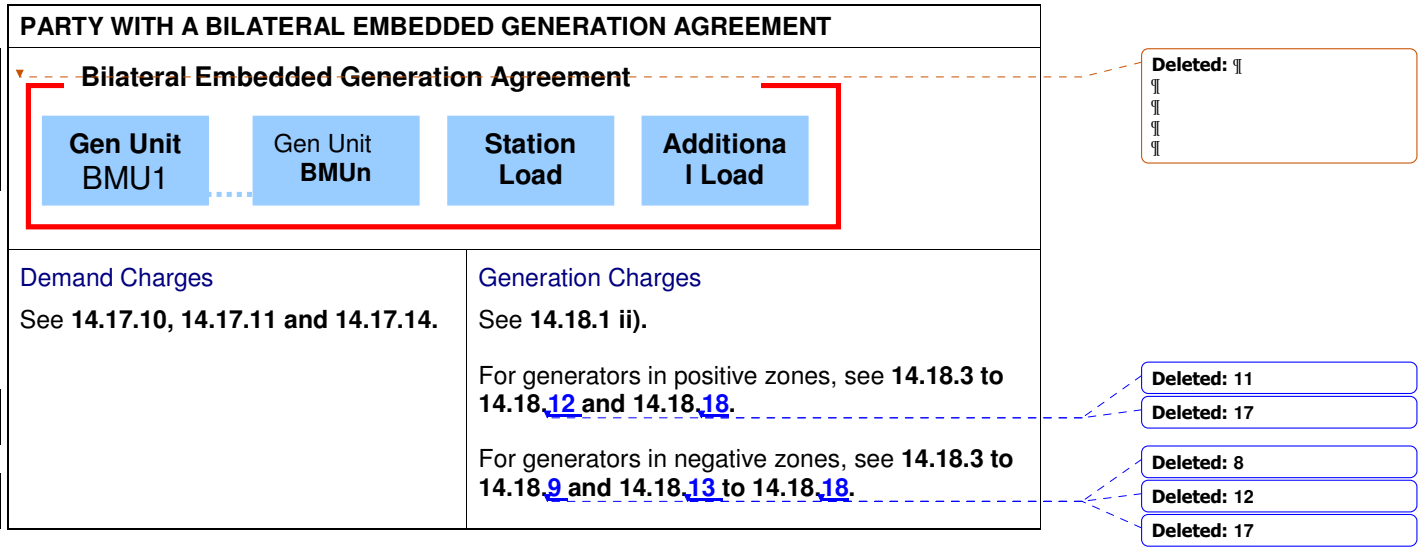

## 14.27 Transmission Network Use of System Charging Flowcharts

Deleted: 6

The following flowcharts illustrate the parties liable for Demand and Generation TNUoS charges and the calculation of those charges.

In the event of any conflict between this Appendix and the main text within this Statement, the main text within the Statement shall take precedence.

### Demand Charges

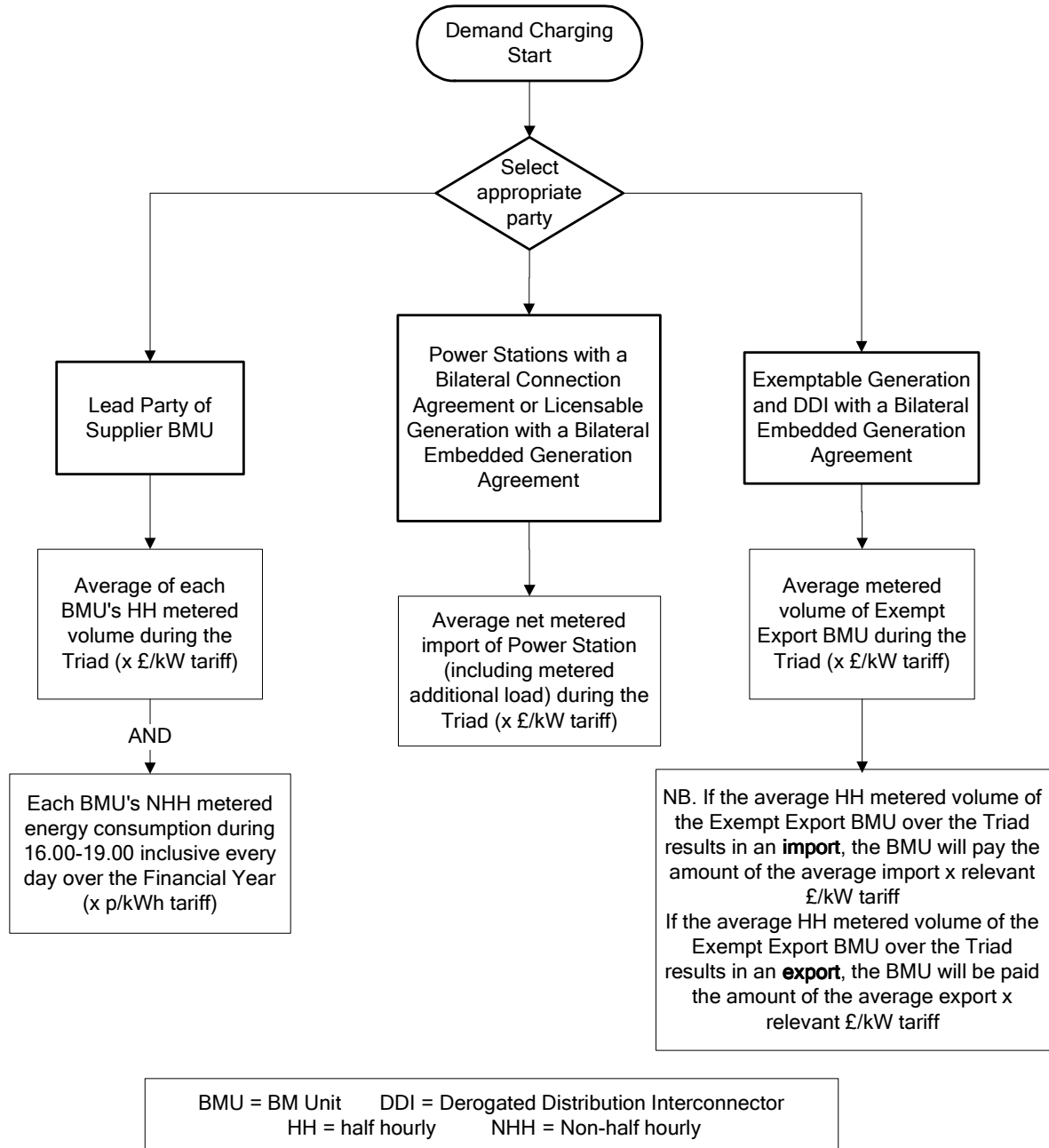

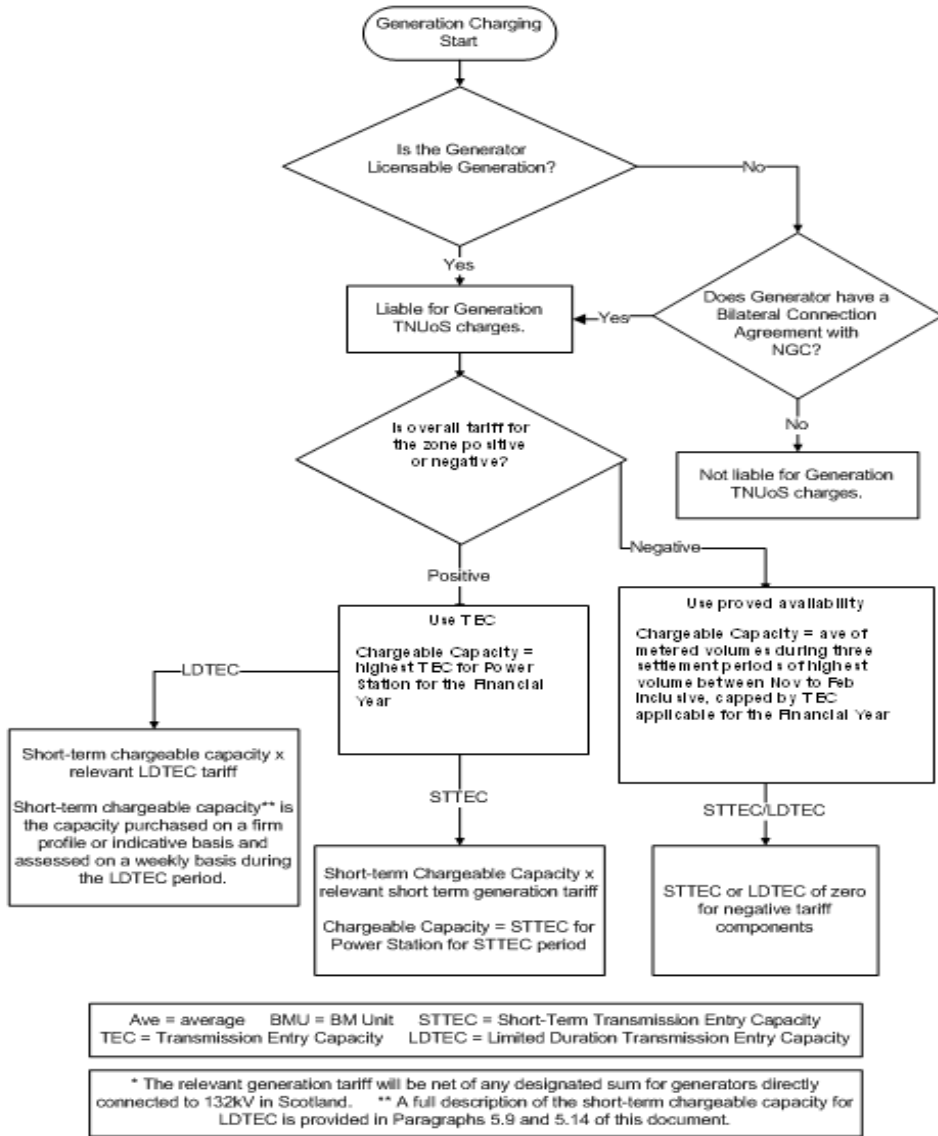

Ave = average BMU = BM Unit STTEC = Short-Term Transmission Entry Capacity  
 TEC = Transmission Entry Capacity LDTEC = Limited Duration Transmission Entry Capacity

\* The relevant generation tariff will be net of any designated sum for generators directly connected to 132kV in Scotland. \*\* A full description of the short-term chargeable capacity for LDTEC is provided in Paragraphs 5.9 and 5.14 of this document.

Short-term chargeable capacity x relevant LDTEC tariff  
 Short-term chargeable capacity\*\* is the capacity purchased on a firm profile or indicative basis and assessed on a weekly basis during the LDTEC period.

Ave  
TEC = T  
 \* Th  
connect

Deleted:



## 14.28 Example: Determination of The Company's Forecast for Demand Charge Purposes

Deleted: 7

The Company will use the latest available settlement data for calculation of HH demand and NHH energy consumption forecasts for the Financial Year.

The Financial Year runs from 1<sup>st</sup> April to 31<sup>st</sup> March inclusive and for the purpose of these examples the year April 2005 to March 2006 is used.

Where the preceding year's settlement data is not available at the time that The Company needs to calculate its forecast, The Company will use settlement data from the corresponding period in Financial Year minus two unless indicated otherwise.

All values used with the examples are purely for illustrative purposes only.

### i) Half-Hourly (HH) Metered Demand Forecast – Existing User

At the time of calculation of a HH demand forecast before the relevant Financial Year (approximately 10<sup>th</sup> March), The Company will be aware at a system level which dates will be used for the determination of Triad. However, The Company may not have settlement data at a User level if the Triad dates were to span a period that includes the latter half of February.

When undertaking forecasting before the relevant Financial Year, The Company will use the User's Triad demand for the previous year for its forecast providing it holds User settlement data for this period, thus:

$$F = T$$

where:

F = Forecast of User's HH demand at Triad for the Financial Year

T = User's HH demand at Triad in Financial Year minus one

Where The Company determines its forecast within a Financial Year:

$$F = T * D/P$$

where:

F = Forecast of User's HH demand at Triad for the Financial Year

T = User's HH demand at Triad in the preceding Financial Year

D = User's average half hourly metered demand in settlement period 35 in the Financial Year to date

P = User's average half hourly metered demand in settlement period 35 for the period corresponding to D in the preceding Financial Year

Where The Company determines its forecast before the relevant Financial Year and User settlement data for the Triad period is not available, The Company shall apply the formula immediately above (within year forecast) but substitute the following definitions for the values T, D, and P:

T = User's HH demand at Triad in the Financial Year minus two

D = User's average half hourly metered demand in settlement period 35 in the Financial Year minus one, to date

P = User's average half hourly metered demand in settlement period 35 for the period corresponding to D in the Financial Year minus two

**Example** (where User settlement data is not yet available for the Triad period):

The Company calculates a HH demand forecast on the above methodology at 10<sup>th</sup> March 2005 for the period 1<sup>st</sup> April 2005 to 31<sup>st</sup> March 2006.

$$F = 10,000 * 13,200 / 12,000$$

$$F = 11,000 \text{ kWh}$$

where:

T = 10,000 kWh (period November 2003 to February 2004)

D = 13,200 kWh (period 1<sup>st</sup> April 2004 to 15<sup>th</sup> February 2005#)

P = 12,000 kWh (period 1<sup>st</sup> April 2003 to 15<sup>th</sup> February 2004)

# Latest date for which settlement data is available.

**ii) Non Half-Hourly (NHH) Metered Energy Consumption Forecast – Existing User**

$$F = E * D/P$$

where:

F = Forecast of User's NHH metered energy consumption for the Financial Year

E = User's summed NHH energy consumption over the hours 16:00 to 19:00 for each day in the preceding Financial Year

D = User's summed NHH energy consumption for the hours 16:00 to 19:00 for each day for the Financial Year to date

P = User's summed NHH energy consumption for the hours 16:00 to 19:00 for each day for the period corresponding to D in the preceding Financial Year

**Example:**

The Company calculates a NHH energy consumption forecast on the above methodology at 10<sup>th</sup> June 2005 for the period 1<sup>st</sup> April 2005 to 31<sup>st</sup> March 2006.

$$F = 50,000,000 * 4,400,000 / 4,000,000$$

$$F = 55,000,000 \text{ kWh}$$

where:

E = 50,000,000 kWh (period 1<sup>st</sup> April 2004 to 31<sup>st</sup> March 2005)

D = 4,400,000 kWh (period 1<sup>st</sup> April 2005 to 15<sup>th</sup> May 2005#)

P = 4,000,000 kWh (period 1<sup>st</sup> April 2004 to 15<sup>th</sup> May 2004)

# Latest date for which settlement data is available

Where forecasting before the relevant Financial Year concerned, The Company would in the above example use values for E and P from Financial Year 2003/04 and D from Financial Year 2004/05.

**iii) Half-Hourly (HH) Metered Demand Forecast – New User**

F = M \* T/W

where:

F = Forecast of User's HH metered demand at Triad for the Financial Year

M = User's HH average weekday period 35 demand for the last complete month for which settlement data is available

T = Total system HH demand at Triad in the preceding Financial Year

W = Total system HH average weekday settlement period 35 metered demand for the corresponding period to M for the preceding year

**Example:**

The Company calculates a HH demand forecast on the above methodology at 10<sup>th</sup> September 2005 for a new User registered from 10<sup>th</sup> June 2005 for the period 10<sup>th</sup> June 2004 to 31<sup>st</sup> March 2006.

F = 1,000 \* 17,000,000 / 18,888,888

F = 900 kWh

where:

M = 1,000 kWh (period 1<sup>st</sup> July 2005 to 31<sup>st</sup> July 2005)

T = 17,000,000 kWh (period November 2004 to February 2005)

W = 18,888,888 kWh (period 1<sup>st</sup> July 2004 to 31<sup>st</sup> July 2004)

**iv) Non Half Hourly (NHH) Metered Energy Consumption Forecast – New User**

F = J + (M \* R/W)

where:

- F = Forecast of User's NHH metered energy consumption for the Financial Year
- J = Residual part month summed NHH metered energy consumption for the hours 16:00 to 19:00 for each day where new User registration takes place other than on the first of a month
- M = User's summed NHH metered energy consumption for the hours 16:00 to 19:00 for each day for the last complete month for which settlement data is available
- R = Total system summed NHH metered energy consumption for the hours 16:00 to 19:00 for each day for the period from the start of that defined under M but for the preceding year and until the end of that preceding Financial Year
- W = Total system summed NHH metered energy consumption for the hours 16:00 to 19:00 for each day for the period identified in M but for the preceding Financial Year

**Example:**

The Company calculates a NHH energy consumption forecast on the above methodology at 10<sup>th</sup> September 2005 for a new User registered from 10<sup>th</sup> June 2005 for the period 10<sup>th</sup> June 2005 to 31<sup>st</sup> March 2006.

$$F = 500 + (1,000 * 20,000,000,000 / 2,000,000,000)$$

$$F = 10,500 \text{ kWh}$$

where:

$$J = 500 \text{ kWh (period 10}^{\text{th}} \text{ June 2005 to 30}^{\text{th}} \text{ June 2005)}$$

$$M = 1,000 \text{ kWh (period 1}^{\text{st}} \text{ July 2005 to 31}^{\text{st}} \text{ July 2005)}$$

$$R = 20,000,000,000 \text{ kWh (period 1}^{\text{st}} \text{ July 2004 to 31}^{\text{st}} \text{ March 2005)}$$

$$W = 2,000,000,000 \text{ kWh (period 1}^{\text{st}} \text{ July 2004 to 31}^{\text{st}} \text{ July 2004)}$$

## 14.29 Stability & Predictability of TNUoS tariffs

Deleted: 8

### Stability of tariffs

The Transmission Network Use of System Charging Methodology has a number of elements to enhance the stability of the tariffs, which is an important aspect of facilitating competition in the generation and supply of electricity. This appendix seeks to highlight those elements.

Each node of the transmission network is assigned to a zone. The result of this is to dampen fluctuations that would otherwise be observed at a given node caused by changes in generation, demand, and network parameters. The criteria used to establish generation zones are part of the methodology and are described in Paragraph 14.15.35.

Deleted: 26

These zones are themselves fixed for the duration of the price control period. The methodology does, however, allow these to be revisited in exceptional circumstances to ensure that the charges remain reasonably cost reflective or to accommodate changes to the network. In rare circumstances where such a re-zoning exercise is required, this will be undertaken in such a way that minimises the adverse impact on Users. This is described in Paragraph 14.15.38.

Deleted: 29

In addition to fixing zones, other key parameters within the methodology are also fixed for the duration of the price control period or annual changes restricted in some way. Specifically:

- the expansion constant, which reflects the annuitised value of capital investment required to transport 1MW over 1km by a 400kV over-head line, changes annually according to RPI. The other elements used to derive the expansion constant are only reviewed at the beginning of a price control period to ensure that it remains cost-reflective. This review will consider those components outlined in Paragraph 14.15.40 to Paragraph 14.15.50.
- the expansion factors, which are set on the same basis of the expansion constant and used to reflect the relative investment costs in each TO region of circuits at different transmission voltages and types, are fixed for the duration price control. These factors are reviewed at the beginning of a price control period and will take account of the same factors considered in the review of the expansion constant.
- the locational security factor, which reflects the transmission security provided under the NETS Security and Quality of Supply Standard, is fixed for the duration of the price control period and reviewed at the beginning of a price control period.

Deleted: 31

Deleted: 41

### Predictability of tariffs

The Company revises TNUoS tariffs each year to ensure that these remain cost-reflective and take into account changes to allowable income under the price control and RPI. There are a number of provisions within The Company's Transmission Licence and the CUSC designed to promote the predictability of annually varying charges. Specifically, The Company is required to give the Authority 150 days notice of its intention to change use of system charges together with a reasonable assessment of the proposals on those charges; and to give Users 2 months written notice of any revised charges. The Company typically provides an additional months notice of revised charges through the publication of "indicative" tariffs. Shorter notice periods are permitted by the framework but only following consent from the Authority.

These features require formal proposals to change the Transmission Use of System Charging Methodology to be initiated in October to provide sufficient time for a formal consultation and the Authority's veto period before charges are indicated to Users.

More fundamentally, The Company also provides Users with the tool used by The Company to calculate tariffs. This allows Users to make their own predictions on how future changes in the generation and supply sectors will influence tariffs. Along with the price control information, the data from the Seven Year Statement, and Users own prediction of market activity, Users are able to make a reasonable estimate of future tariffs and perform sensitivity analysis.

To supplement this, The Company also prepares an annual information paper that provides an indication of the future path of the locational element of tariffs over the next five years.<sup>4</sup> This analysis is based on data included within the Seven Year Statement. This report typically includes:

- an explanation of the events that have caused tariffs to change;
- sensitivity analysis to indicate how generation and demand tariffs would change as a result of changes in generation and demand at certain points on the network that are not included within the SYS;
- an assessment of the compliance with the zoning criteria throughout the five year period to indicate how generation zones might need to change in the future, with a view to minimising such changes and giving as much notice of the need, or potential need, to change generation zones; and
- a complete dataset for the DCLF Transport Model developed for each future year, to allow Users to undertake their own sensitivity analysis for specific scenarios that they may wish to model.

The first year of tariffs forecasted in the annual information paper are updated twice throughout the proceeding financial year as the various Transport and Tariff model inputs are received or amended. These updates are in addition to the Authority 150 days notice and publication of “indicative” tariffs.

| In addition, The Company will, when revising generation charging zones prior to a new price control period, undertake a zoning consultation that uses data from the latest information paper. The purpose of this consultation will be to ensure tariff zones are robust to contracted changes in generation and supply, which could be expected to reduce the need for re-zoning exercises within a price control period.

**Formatted:** Justified

**Deleted:** ¶  
¶  
¶  
-----Page Break-----  
¶

<sup>4</sup> <http://www.nationalgrid.com/uk/Electricity/Charges/gbchargingapprovalconditions/5/>



## CUSC - SECTION 14

### CHARGING METHODOLOGIES

#### CONTENTS

Part 2 -The Statement of the Use of System Charging Methodology	<b>Formatted:</b> Font: Bold
Section 1 – The Statement of the Transmission Use of System Charging Methodology;	<b>Formatted:</b> Centered
	<b>Deleted:</b> ¶
14.14 Principles	
14.15 Derivation of Transmission Network Use of System Tariff	
14.16 Derivation of the Transmission Network Use of System Energy Consumption Tariff and Short Term Capacity Tariffs	
14.17 Demand Charges	
14.18 Generation Charges	
14.19 Data Requirements	
14.20 Applications	
14.21 Transport Model Example	
<a href="#">14.22 Illustrative Calculation of Boundary Sharing Factors (BSFs) and Shared / Not-Shared incremental km</a>	<b>Formatted:</b> Font: Arial, 12 pt, Not Bold, Not Highlight
<a href="#">14.23 Example: Calculation of Zonal Generation Tariffs and Charges</a>	<b>Deleted:</b> 2
<a href="#">14.24 Example: Calculation of Zonal Demand Tariff</a>	<b>Deleted:</b> 3
<a href="#">14.25 Reconciliation of Demand Related Transmission Network Use of System Charges</a>	<b>Deleted:</b> 4
<a href="#">14.26 Classification of parties for charging purposes</a>	<b>Deleted:</b> 5
<a href="#">14.27 Transmission Network Use of System Charging Flowcharts</a>	<b>Deleted:</b> 6
<a href="#">14.28 Example: Determination of The Company's Forecast for Demand Charge Purposes</a>	<b>Deleted:</b> 7
<a href="#">14.29 Stability &amp; Predictability of TNUoS tariffs</a>	<b>Deleted:</b> 8
Section 2 – The Statement of the Balancing Services Use of System Charging Methodology	



14.30 Principles

Deleted: 29

14.31 Calculation of the Daily Balancing Services Use of System charge

Deleted: 0

14.32 Settlement of BSUoS

Deleted: 1

14.33 Examples of Balancing Services Use of System (BSUoS) Daily Charge Calculations

Deleted: 2

## CUSC - SECTION 14

### CHARGING METHODOLOGIES

14.1 Introduction

14.1.1 This section of the CUSC sets out the statement of the Connection Charging Methodology and the Statement of the Use of System Methodology

← **Formatted:** Tabs: 2.77 cm,  
List tab + Not at 1.5 cm

← **Formatted:** Tabs: 3.63 cm,  
List tab + Not at 3 cm

← **Formatted:** 1,2,3, Justified,  
Indent: Left: 0 cm

## Part 2 - The Statement of the Use of System Charging Methodology

Deleted:  
Formatted: Font: Arial (W1)  
Deleted: ¶

### Section 1 – The Statement of the Transmission Use of System Charging Methodology

#### 14.14 Principles

**14.14.1** Transmission Network Use of System charges reflect the cost of installing, operating and maintaining the transmission system for the Transmission Owner (TO) Activity function of the Transmission Businesses of each Transmission Licensee. These activities are undertaken to the standards prescribed by the Transmission Licences, to provide the capability to allow the flow of bulk transfers of power between connection sites and to provide transmission system security.

Formatted: Indent: Left: 1.27 cm, Numbered + Level: 1 + Numbering Style: 1, 2, 3, ... + Start at: 1 + Alignment: Left + Aligned at: 0 cm + Tab after: 0 cm + Indent at: 1.6 cm, Tabs: 1.9 cm, List tab + Not at 0 cm + 1.27 cm

**14.14.2** A Maximum Allowed Revenue (MAR) defined for these activities and those associated with pre-vesting connections is set by the Authority at the time of the Transmission Owners' price control review for the succeeding price control period. Transmission Network Use of System Charges are set to recover the Maximum Allowed Revenue as set by the Price Control (where necessary, allowing for any  $K_t$  adjustment for under or over recovery in a previous year net of the income recovered through pre-vesting connection charges).

Formatted: Indent: Left: 1.27 cm, Numbered + Level: 1 + Numbering Style: 1, 2, 3, ... + Start at: 1 + Alignment: Left + Aligned at: 0 cm + Tab after: 0 cm + Indent at: 1.6 cm, Tabs: 1.9 cm, List tab + Not at 0 cm + 1.27 cm

**14.14.3** The basis of charging to recover the allowed revenue is the Investment Cost Related Pricing (ICRP) methodology, which was initially introduced by The Company in 1993/94 for England and Wales. The principles and methods underlying the ICRP methodology were set out in the The Company document "**Transmission Use of System Charges Review: Proposed Investment Cost Related Pricing for Use of System (30 June 1992)**".

Formatted: Indent: Left: 1.27 cm, Numbered + Level: 1 + Numbering Style: 1, 2, 3, ... + Start at: 1 + Alignment: Left + Aligned at: 0 cm + Tab after: 0 cm + Indent at: 1.6 cm, Tabs: 1.9 cm, List tab + Not at 0 cm + 1.27 cm

**14.14.4** In December 2003, The Company published the Initial Thoughts consultation for a GB methodology using the England and Wales methodology as the basis for consultation. The Initial Methodologies consultation published by The Company in May 2004 proposed two options for a GB charging methodology with a Final Methodologies consultation published in August 2004 detailing The Company's response to the Industry with a recommendation for the GB charging methodology. In December 2004, The Company published a Revised Proposals consultation in response to the Authority's invitation for further review on certain areas in The Company's recommended GB charging methodology.

Formatted: Indent: Left: 1.27 cm, Numbered + Level: 1 + Numbering Style: 1, 2, 3, ... + Start at: 1 + Alignment: Left + Aligned at: 0 cm + Tab after: 0 cm + Indent at: 1.6 cm, Tabs: 1.9 cm, List tab + Not at 0 cm + 1.27 cm

**14.14.5** In April 2004 The Company introduced a DC Loadflow (DCLF) ICRP based transport model for the England and Wales charging methodology. The DCLF model has been extended to incorporate Scottish network data with existing England and Wales network data to form the GB network in the model. In April 2005, the GB charging methodology implemented the following proposals:

Formatted: Numbered + Level: 1 + Numbering Style: 1, 2, 3, ... + Start at: 5 + Alignment: Left + Aligned at: 1.27 cm + Tab after: 1.27 cm + Indent at: 2.87 cm, Tabs: 1.9 cm, List tab + Not at 1.27 cm

**i.)** The application of multi-voltage circuit expansion factors with a forward-looking Expansion Constant that does not include substation costs in its derivation.

Formatted: Indent: Left: 2.54 cm, Numbered + Level: 1 + Numbering Style: i, ii, iii, ... + Start at: 1 + Alignment: Left + Aligned at: 1.27 cm + Tab after: 2.54 cm + Indent at: 2.54 cm, Tabs: Not at 1.27 cm + 2.54 cm

**ii.)** The application of locational security costs, by applying a multiplier to the Expansion Constant reflecting the difference in cost incurred on a secure network as opposed to an unsecured network.

Formatted: Indent: Left: 2.54 cm, Numbered + Level: 1 + Numbering Style: i, ii, iii, ... + Start at: 1 + Alignment: Left + Aligned at: 1.27 cm + Tab after: 2.54 cm + Indent at: 2.54 cm, Tabs: Not at 1.27 cm + 2.54 cm

- iii.) The application of a de-minimus level demand charge of £0/kW for Half Hourly and £0/kWh for Non Half Hourly metered demand to avoid the introduction of negative demand tariffs.
- iv.) The application of 132kV expansion factor on a Transmission Owner basis reflecting the regional variations in network upgrade plans.
- v.) The application of a Transmission Network Use of System Revenue split between generation and demand of 27% and 73% respectively.
- vi.) The number of generation zones using the criteria outlined in paragraph 14.15.33 has been determined as 21.
- vii.) The number of demand zones has been determined as 14, corresponding to the 14 GSP groups.

14.14.6 The underlying rationale behind Transmission Network Use of System charges is that efficient economic signals are provided to Users when services are priced to reflect the incremental costs of supplying them. Therefore, charges should reflect the impact that Users of the transmission system at different locations would have on the Transmission Owner's costs, if they were to increase or decrease their use of the respective systems. These costs are primarily defined as the investment costs in the transmission system, maintenance of the transmission system and maintaining a system capable of providing a secure bulk supply of energy.

The Transmission Licence requires The Company to operate the National Electricity Transmission System to specified standards. In addition The Company with other transmission licensees are required to plan and develop the National Electricity Transmission System to meet these standards. These requirements mean that the system must conform to a particular Security Standard and capital investment requirements are largely driven by the need to conform to both the deterministic and supporting cost benefit analysis aspects of this standard. It is this obligation, which provides the underlying rationale for the ICRP approach, i.e. for any changes in generation and demand on the system, The Company must ensure that it satisfies the requirements of the Security Standard.

14.14.7 The Security Standard identifies requirements on the capacity of component sections of the system given the expected generation and demand at each node, such that demand can be met and generators' output over the course of a year (capped at their Transmission Entry Capacity, TEC) can be accommodated in the most economic and efficient manner. The derivation of the incremental investment costs at different points on the system is therefore determined against the requirements of the system both at the time of peak demand and across the remainder of the year. The Security Standard uses a Demand Security Criterion and an Economy Criterion to assess capacity requirements. The charging methodology therefore recognises both these elements in its rationale.

14.14.8 The Demand Security Criterion requires sufficient transmission system capacity such that peak demand can be met through generation sources as defined in the Security Standard, whilst the Economy Criterion requires sufficient transmission system capacity to accommodate all types of generation in order to meet varying levels of demand efficiently. The latter is achieved through a set of deterministic parameters that have been derived from a generic Cost Benefit Analysis (CBA) seeking to identify an appropriate balance between constraint costs and the costs of transmission reinforcements.

**Formatted:** Indent: Left: 2.54 cm, Numbered + Level: 1 + Numbering Style: i, ii, iii, ... + Start at: 1 + Alignment: Left + Aligned at: 1.27 cm + Tab after: 2.54 cm + Indent at: 2.54 cm, Tabs: Not at 1.27 cm + 2.54 cm

**Formatted:** Indent: Left: 2.54 cm, Numbered + Level: 1 + Numbering Style: i, ii, iii, ... + Start at: 1 + Alignment: Left + Aligned at: 1.27 cm + Tab after: 2.54 cm + Indent at: 2.54 cm, Tabs: Not at 1.27 cm + 2.54 cm

**Formatted:** Indent: Left: 2.54 cm, Numbered + Level: 1 + Numbering Style: i, ii, iii, ... + Start at: 1 + Alignment: Left + Aligned at: 1.27 cm + Tab after: 2.54 cm + Indent at: 2.54 cm, Tabs: Not at 1.27 cm + 2.54 cm

**Formatted:** Indent: Left: 2.54 cm, Numbered + Level: 1 + Numbering Style: i, ii, iii, ... + Start at: 1 + Alignment: Left + Aligned at: 1.27 cm + Tab after: 2.54 cm + Indent at: 2.54 cm, Tabs: Not at 1.27 cm + 2.54 cm

**Deleted:** 26

**Formatted:** Indent: Left: 2.54 cm, Numbered + Level: 1 + Numbering Style: 1, 2, 3, ... + Start at: 5 + Alignment: Left + Aligned at: 1.27 cm + Tab after: 1.27 cm + Indent at: 2.87 cm, Tabs: 1.9 cm, List tab + Not at 1.27 cm

**Formatted:** Numbered + Level: 1 + Numbering Style: 1, 2, 3, ... + Start at: 5 + Alignment: Left + Aligned at: 1.27 cm + Tab after: 1.27 cm + Indent at: 2.87 cm, Tabs: 1.9 cm, List tab + Not at 1.27 cm

**Deleted:** Capacities (TECs)

**Deleted:** .

**Deleted:** this peak element

**Formatted:** Indent: Left: 1.27 cm

**Deleted:** 14.14.8

**Formatted:** ... [1]

14.14.9 The TNUoS charging methodology seeks to reflect these arrangements through the use of dual backgrounds in the Transport Model, namely a Peak Security background representative of the Demand Security Criterion and a Year Round background representative of the Economy Criterion.

**Formatted:** Numbered + Level: 1 + Numbering Style: 1, 2, 3, ... + Start at: 5 + Alignment: Left + Aligned at: 1.27 cm + Tab after: 1.27 cm + Indent at: 2.87 cm, Tabs: 1.9 cm, List tab + Not at 1.27 cm

14.14.10 To recognise that various types of generation will have a different impact on incremental investment costs the charging methodology uses a generator's TEC, Peak Security flag, and Annual Load Factor (ALF) when determining Transmission Network Use of System charges relating to the Peak Security and Year Round backgrounds respectively. For the Year Round background the diversity of the plant mix (i.e the proportion of low carbon and carbon generation) in each charging zone is also taken into account.

**Formatted:** Numbered + Level: 1 + Numbering Style: 1, 2, 3, ... + Start at: 5 + Alignment: Left + Aligned at: 1.27 cm + Tab after: 1.27 cm + Indent at: 2.87 cm, Tabs: 1.9 cm, List tab + Not at 1.27 cm

14.14.11 In setting and reviewing these charges The Company has a number of further objectives. These are to:

**Formatted:** Highlight  
**Formatted:** Highlight  
**Formatted:** Highlight  
**Formatted:** Highlight

- offer clarity of principles and transparency of the methodology;
- inform existing Users and potential new entrants with accurate and stable cost messages;
- charge on the basis of services provided and on the basis of incremental rather than average costs, and so promote the optimal use of and investment in the transmission system; and
- be implementable within practical cost parameters and time-scales.

**Formatted:** Numbered + Level: 1 + Numbering Style: 1, 2, 3, ... + Start at: 5 + Alignment: Left + Aligned at: 1.27 cm + Tab after: 1.27 cm + Indent at: 2.87 cm, Tabs: 1.9 cm, List tab + Not at 1.27 cm

14.14.12 Condition C13 of The Company's Transmission Licence governs the adjustment to Use of System charges for small generators. Under the condition, The Company is required to reduce TNUoS charges paid by eligible small generators by a designated sum, which will be determined by the Authority. The licence condition describes an adjustment to generator charges for eligible plant, and a consequential change to demand charges to recover any shortfall in revenue. The mechanism for recovery will ensure revenue neutrality over the lifetime of its operation although it does allow for effective under or over recovery within any year. For the avoidance of doubt, Condition C13 does not form part of the Use of System Charging Methodology.

**Formatted:** Indent: Left: 2.5 cm, Hanging: 1.29 cm, Bulleted + Level: 1 + Aligned at: 0 cm + Tab after: 0.63 cm + Indent at: 0.63 cm, Tabs: 3.89 cm, List tab + Not at 0.63 cm + 1.27 cm

14.14.13 The Company will typically calculate TNUoS tariffs annually, publishing final tariffs in respect of a Financial Year by the end of the preceding January. However The Company may update the tariffs part way through a Financial Year.

**Formatted:** Numbered + Level: 1 + Numbering Style: 1, 2, 3, ... + Start at: 12 + Alignment: Left + Aligned at: 1.27 cm + Tab after: 1.27 cm + Indent at: 2.87 cm

**Formatted:** Numbered + Level: 1 + Numbering Style: 1, 2, 3, ... + Start at: 12 + Alignment: Left + Aligned at: 1.27 cm + Tab after: 1.27 cm + Indent at: 2.87 cm

## 14.15 Derivation of the Transmission Network Use of System Tariff

**14.15.1** The Transmission Network Use of System (TNUoS) Tariff comprises two separate elements. Firstly, a locationally varying element derived from the DCLF ICRP transport model to reflect the costs of capital investment in, and the maintenance and operation of, a transmission system to provide bulk transport of power to and from different locations. Secondly, a non-locationally varying element related to the provision of residual revenue recovery. The combination of both these elements forms the TNUoS tariff.

**Formatted:** Numbered + Level: 1 + Numbering Style: 1, 2, 3, ... + Start at: 1 + Alignment: Left + Aligned at: 1.69 cm + Tab after: 1.69 cm + Indent at: 3.29 cm, Tabs: Not at 1.27 cm

**14.15.2** For generation TNUoS tariffs the locational element itself is comprised of **five** separate components. **Three** wider components -

- o Wider Peak Security component
- o Wider Year Round Not-shared component
- o Wider Year Round Shared component

These components reflect the costs of the wider network under the different generation backgrounds set out in the Demand Security Criterion (for Peak Security component) and Economy Criterion (for both Year Round components) of the Security Standard. The two Year Round components reflect the unshared and shared costs of the wider network based on the diversity of generation plant types.

Two local components -

- o Local substation, and
- o Local circuit

These components reflect the costs of the local network.

Accordingly, the wider tariff represents the combined effect of the **three** wider locational tariff components and the residual element; and the local tariff represents the combination of the two local locational tariff components.

**Deleted:** three  
**Formatted:** Highlight  
**Deleted:** A  
**Formatted:** Highlight  
**Deleted:** component reflects  
**Formatted:** Highlight  
**Formatted:** Bullets and Numbering  
**Formatted:** Highlight  
**Formatted:** Highlight  
**Formatted:** Highlight  
**Formatted:** Highlight  
**Deleted:** , and  
**Deleted:** combination of a  
**Formatted:** Highlight  
**Formatted:** Highlight  
**Deleted:** a local  
**Deleted:** component  
**Deleted:**  
**Formatted:** Indent: Left: 2.87 cm, No bullets or numbering, Tabs: Not at 1.27  
**Formatted:** Highlight

**14.15.3** The process for calculating the TNUoS tariff is described below.

### The Transport Model

#### Model Inputs

**14.15.4** The DCLF ICRP transport model calculates the marginal costs of investment in the transmission system which would be required as a consequence of an increase in demand or generation at each connection point or node on the transmission system, based on a study of peak demand conditions using both Peak Security and Year Round generation backgrounds on the transmission system. One measure of the investment costs is in terms of MWkm. This is the concept that ICRP uses to calculate marginal costs of investment. Hence, marginal costs are estimated initially in terms of increases or decreases in units of kilometres (km) of the transmission system for a 1 MW injection to the system.

**Formatted:** Numbered + Level: 1 + Numbering Style: 1, 2, 3, ... + Start at: 1 + Alignment: Left + Aligned at: 1.69 cm + Tab after: 1.69 cm + Indent at: 3.29 cm, Tabs: Not at 1.27 cm  
**Formatted:** Numbered + Level: 1 + Numbering Style: 1, 2, 3, ... + Start at: 1 + Alignment: Left + Aligned at: 1.69 cm + Tab after: 1.69 cm + Indent at: 3.29 cm, Tabs: Not at 1.27 cm

**14.15.5** The transport model requires a set of inputs representative of the Demand Security and Economy Criterion set out in the Security Standards. These conditions on the transmission system are represented in the Peak Security and Year Round background respectively as follows:

**Formatted:** Numbered + Level: 1 + Numbering Style: 1, 2, 3, ... + Start at: 1 + Alignment: Left + Aligned at: 1.69 cm + Tab after: 1.69 cm + Indent at: 3.29 cm, Tabs: Not at 1.27 cm  
**Deleted:** peak

- Nodal generation information per node (TEC, plant type and SOSS scaling factors)
- Nodal demand information
- Transmission circuits between these nodes
- The associated lengths of these routes, the proportion of which is overhead line or cable and the respective voltage level
- The cost ratio of each of 132kV overhead line, 132kV underground cable, 275kV overhead line, 275kV underground cable and 400kV underground cable to 400kV overhead line to give circuit expansion factors
- The cost ratio of each separate sub-sea AC circuit and HVDC circuit to 400kV overhead line to give circuit expansion factors
- 132kV overhead circuit capacity and single/double route construction information is used in the calculation of a generator's local charge.
- Offshore transmission cost and circuit/substation data

**Formatted:** Indent: Left: 3 cm, Hanging: 1 cm, Bulleted + Level: 1 + Aligned at: 0 cm + Tab after: 0.63 cm + Indent at: 0.63 cm, Tabs: 4.02 cm, List tab + Not at 0.63 cm + 1.27 cm

**Deleted:** costs

14.15.6 For a given charging year "t", the nodal generation TEC figure and generation plant types at each node will be based on the Applicable Value for year "t" in the NETS Seven Year Statement in year "t-1" plus updates to the October of year "t-1". The contracted TECs and generation plant types in the NETS Seven Year Statement include all plant belonging to generators who have a Bilateral Agreement with the TOs. For example, for 2010/11 charges, the nodal generation data is based on the forecast for 2010/11 in the 2009 NETS Seven Year Statement plus any data included in the quarterly updates in October 2009.

**Deleted:** Identification of a reference node

**Formatted:** Numbered + Level: 1 + Numbering Style: 1, 2, 3, ... + Start at: 1 + Alignment: Left + Aligned at: 1.69 cm + Tab after: 1.69 cm + Indent at: 3.29 cm, Tabs: Not at 1.27 cm

14.15.7 Scaling factors for different generation plant types are applied on their aggregated capacity for both Peak Security and Year Round backgrounds. The scaling is either Fixed or Variable (depending on the total demand level) in line with the factors used in the Security Standard, for example as shown in the table below.

<u>Generation Plant Type</u>	<u>Peak Security Background</u>	<u>Year Round Background</u>
<u>Intermittent</u>	<u>Fixed (0%)</u>	<u>Fixed (70%)</u>
<u>Nuclear &amp; CCS</u>	<u>Variable</u>	<u>Fixed (85%)</u>
<u>Interconnectors</u>	<u>Fixed (0%)</u>	<u>Fixed (100%)</u>
<u>Hydro</u>	<u>Variable</u>	<u>Variable</u>
<u>Pumped Storage</u>	<u>Variable</u>	<u>Fixed (50%)</u>
<u>Peaking</u>	<u>Variable</u>	<u>Fixed (0%)</u>
<u>Other (Conventional)</u>	<u>Variable</u>	<u>Variable</u>

These scaling factors and generation plant types are set out in the Security Standard. These may be reviewed from time to time. The latest version will be used in the calculation of TNUoS tariffs and is published in the Statement of Use of System Charges

**Formatted:** Indent: Left: 1.9 cm

**Formatted:** Numbered + Level: 1 + Numbering Style: 1, 2, 3, ... + Start at: 1 + Alignment: Left + Aligned at: 1.69 cm + Tab after: 1.69 cm + Indent at: 3.29 cm, Tabs: Not at 1.27 cm

14.15.8 National Grid will categorise plant based on the categorisations described in the Security Standard. Peaking plant will include oil and OCGT technologies and Other (Conv.) represents all remaining conventional plant not explicitly stated elsewhere in the tabl. In the event that a power station is made up of more than one technology type, the type of the higher Transmission Entry Capacity (TEC) would apply.

**Formatted:** Indent: Left: 1.69 cm, No bullets or numbering, Tabs: 1.9 cm, List tab + Not at 1.27 cm

14.15.9 Nodal demand data for the transport model will be based upon the GSP demand that Users have forecast to occur at the time of National Grid Peak Average Cold Spell (ACS) Demand for year "t" in the April Seven Year Statement for year "t-1" plus updates to the October of year "t-1".

**Formatted:** Numbered + Level: 1 + Numbering Style: 1, 2, 3, ... + Start at: 1 + Alignment: Left + Aligned at: 1.69 cm + Tab after: 1.69 cm + Indent at: 3.29 cm, Tabs: Not at 1.27 cm

**Formatted:** Indent: Left: 0.63 cm

**14.15.10** Transmission circuits for charging year "t" will be defined as those with existing wayleaves for the year "t" with the associated lengths based on the circuit lengths indicated for year "t" in the April NETS Seven Year Statement for year "t-1" plus updates to October of year "t-1". If certain circuit information is not explicitly contained in the NETS Seven Year Statement, The Company will use the best information available.

**Formatted:** Numbered + Level: 1 + Numbering Style: 1, 2, 3, ... + Start at: 1 + Alignment: Left + Aligned at: 1.69 cm + Tab after: 1.69 cm + Indent at: 3.29 cm, Tabs: Not at 1.27 cm

**14.15.11** The circuit lengths included in the transport model are solely those, which relate to assets defined as 'Use of System' assets.

**Formatted:** Indent: Left: 0.63 cm

**14.15.12** For HVDC circuits, the impedance will be calculated to provide flows based on a ratio of the capacity provided by the HVDC link relative to the capacities on all major transmission system boundaries that it parallels.

**Formatted:** Indent: Left: 1.9 cm, Numbered + Level: 1 + Numbering Style: 1, 2, 3, ... + Start at: 1 + Alignment: Left + Aligned at: 1.69 cm + Tab after: 1.69 cm + Indent at: 3.29 cm, Tabs: Not at 1.27 cm

**14.15.13** The transport model employs the use of circuit expansion factors to reflect the difference in cost between (i) AC circuits and HVDC circuits, (ii) underground and sub-sea circuits, (iii) cabled circuits and overhead line circuits, (iv) 132kV and 275kV circuits, (v) 275kV circuits and 400kV circuits, and (vi), uses 400kV overhead line (i.e. the 400kV overhead line expansion factor is 1). As the transport model expresses cost as marginal km (irrespective of cables or overhead lines), some account needs to be made of the fact that investment in these other types of circuit (specifically HVDC and sub-sea cables of various voltages, 400kV underground cable, 275kV overhead line, 275kV underground cable, 132kV overhead line and 132kV underground cable) is more expensive than for 400kV overhead line. This is done by effectively 'expanding' these more expensive circuits by the relevant circuit expansion factor, thereby producing a larger marginal kilometre to reflect the additional cost of investing in these circuits compared to 400kV overhead line. When calculating the local circuit tariff for a generator, alternative 132kV and offshore expansion factors to those used in the remainder of the tariff calculation are applied to the generator's local circuits.

**Formatted:** Indent: Left: 0.63 cm

**Formatted:** Indent: Left: 1.9 cm, Numbered + Level: 1 + Numbering Style: 1, 2, 3, ... + Start at: 1 + Alignment: Left + Aligned at: 1.69 cm + Tab after: 1.69 cm + Indent at: 3.29 cm, Tabs: Not at 1.27 cm

**Formatted:** Indent: Left: 1.9 cm, Numbered + Level: 1 + Numbering Style: 1, 2, 3, ... + Start at: 1 + Alignment: Left + Aligned at: 1.69 cm + Tab after: 1.69 cm + Indent at: 3.29 cm, Tabs: Not at 1.27 cm

**Deleted:** routes

**Deleted:** routes, (ii)

**Deleted:** routes, (iii)

**Deleted:** routes

**Deleted:** routes

**Deleted:** iv

**14.15.14** The circuit expansion factors for HVDC circuits and AC subsea cables are determined on a case by case basis using the costs which are specific to the individual projects containing HVDC or AC subsea circuits.

**Model Outputs**

**14.15.15** The transport model takes the inputs described above and carries out the following steps individually for Peak Security and Year Round backgrounds.

**Formatted:** Indent: Left: 1.9 cm

**Deleted:** A reference node is required as a

**Formatted** ... [2]

**Deleted:** point for

**Deleted:** calculation of marginal

**Deleted:** . It determines t ... [3]

**Deleted:** North of Scotlar ... [4]

**Deleted:** ¶

**Formatted** ... [5]

**Formatted** ... [6]

**Formatted** ... [7]

**Deleted:** firstly scales

**Deleted:** nodal

**Formatted** ... [8]

**Deleted:** capacity

**Deleted:** The

**Formatted** ... [9]

**Deleted:** for

**14.15.17** For each background, the model then uses a DCLF ICRP transport algorithm to derive the resultant pattern of flows based on the network impedance required to meet the nodal demand using the scaled nodal generation, assuming every circuit has infinite capacity. Flows on individual transmission circuits are compared for both backgrounds and the background giving rise to the highest flow is considered as the triggering criterion for future investment of that circuit for the purposes of the charging methodology. Therefore all circuits will be tagged as Peak Security or Year Round depending upon the background resulting in the highest flow. In the event that both backgrounds result in the same flow, the circuit will be tagged as Peak Security. Then it calculates the resultant total network Peak Security MWkm



and Year Round MWkm, using the relevant circuit expansion factors as appropriate.

14.15.18 Using these baseline networks for Peak Security and Year Round backgrounds, the model then calculates for a given injection of 1MW of generation at each node, with a corresponding 1MW offtake (demand) distributed across all demand nodes in the network, the increase or decrease in total MWkm of the whole Peak Security and Year Round networks. The proportion of the 1MW offtake allocated to any given demand node will be based on total background nodal demand in the model. For example, with a total GB demand of 60GW in the model, a node with a demand of 600MW would contain 1% of the offtake i.e. 0.01MW.

14.15.19 Given the assumption of a 1MW injection, for simplicity the marginal costs are expressed solely in km. This gives a Peak Security marginal km cost and a Year Round marginal km cost for generation at each node (although not that used to calculate generation tariffs which considers local and wider cost components). The Peak Security and Year Round marginal km costs for demand at each node are equal and opposite to the Peak Security and Year Round nodal marginal km respectively for generation and these are used to calculate demand tariffs. Note the marginal km costs can be positive or negative depending on the impact the injection of 1MW of generation has on the total circuit km.

14.15.20 Using a similar methodology as described above in 14.15.18, the local and wider marginal km costs used to determine generation TNUoS tariffs are calculated by injecting 1MW of generation against the node(s) the generator is modelled at and increasing by 1MW the offtake across the distributed reference node. It should be noted that although the wider marginal km costs are calculated for both Peak Security and Year Round backgrounds, the local marginal km costs are calculated on the Year Round background.

14.15.21 In addition, any circuits in the model, identified as local assets to a node will have the local circuit expansion factors which are applied in calculating that particular node's marginal km. Any remaining circuits will have the TO specific wider circuit expansion factors applied.

14.15.22 An example is contained in 14.21 Transport Model Example.

### Calculation of local nodal marginal km

14.15.23 In order to ensure assets local to generation are charged in a cost reflective manner, a generation local circuit tariff is calculated. The nodal specific charge provides a financial signal reflecting the security and construction of the infrastructure circuits that connect the node to the transmission system.

14.15.24 Main Interconnected Transmission System (MITS) nodes are defined as:

- Grid Supply Point connections with 2 or more transmission circuits connecting at the site; or
- connections with more than 4 transmission circuits connecting at the site.

14.15.25 Where a Grid Supply Point is defined as a point of supply from the National Electricity Transmission System to network operators or non-embedded customers excluding generator or interconnector load alone. For the avoidance of doubt, generator or interconnector load would be subject to the circuit component of its Local Charge. A transmission circuit is part of the National Electricity Transmission System between two or more circuit-breakers which includes transformers, cables and overhead lines but excludes busbars and generation circuits.

**Formatted:** Indent: Left: 0.63 cm  
**Deleted:** this

**Formatted:** Indent: Left: 1.9 cm, Numbered + Level: 1 + Numbering Style: 1, 2, 3, ... + Start at: 1 + Alignment: Left + Aligned at: 1.69 cm + Tab after: 1.69 cm + Indent at: 3.29 cm, Tabs: Not at 1.27 cm  
**Deleted:** at the reference node,  
**Deleted:** network.

**Formatted:** Indent: Left: 1.9 cm, Numbered + Level: 1 + Numbering Style: 1, 2, 3, ... + Start at: 1 + Alignment: Left + Aligned at: 1.69 cm + Tab after: 1.69 cm + Indent at: 3.29 cm, Tabs: Not at 1.27 cm  
**Deleted:** cost  
**Deleted:** node  
**Deleted:** this  
**Deleted:** this is

**Formatted:** Indent: Left: 1.9 cm, Numbered + Level: 1 + Numbering Style: 1, 2, 3, ... + Start at: 1 + Alignment: Left + Aligned at: 1.69 cm + Tab after: 1.69 cm + Indent at: 3.29 cm, Tabs: Not at 1.27 cm  
**Deleted:** at  
**Deleted:**

**Formatted:** Indent: Left: 1.9 cm, Numbered + Level: 1 + Numbering Style: 1, 2, 3, ... + Start at: 1 + Alignment: Left + Aligned at: 1.69 cm + Tab after: 1.69 cm + Indent at: 3.29 cm, Tabs: Not at 1.27 cm  
**Deleted:** this model,

**Formatted:** Indent: Left: 0.63 cm  
**Formatted:** Indent: Left: 1.9 cm, Numbered + Level: 1 + Numbering Style: 1, 2, 3, ... + Start at: 1 + Alignment: Left + Aligned at: 1.69 cm + Tab after: 1.69 cm + Indent at: 3.29 cm, Tabs: Not at 1.27 cm  
**Formatted:** Indent: Left: 0.63 cm  
**Formatted:** Justified, Indent: Left: 1.9 cm  
**Formatted:** Indent: Left: 1.9 cm, Bulleted + Level: 1 + Aligned at: 0.63 cm + Tab after: 1.27 cm + Indent at: 1.27 cm

**14.15.26** Generators directly connected to a MITS node will have a zero local circuit tariff.

**Formatted:** Bullets and Numbering

**14.15.27** Generators not connected to a MITS node will have a local circuit tariff derived from the local nodal marginal km for the generation node i.e. the increase or decrease in marginal km along the transmission circuits connecting it to all adjacent MITS nodes (local assets).

**Formatted:** Indent: Left: 0.63 cm

**Formatted:** Bullets and Numbering

**Formatted:** Indent: Left: 0.63 cm

**Calculation of zonal marginal km**

**14.15.28** Given the requirement for relatively stable cost messages through the ICRP methodology and administrative simplicity, nodes are assigned to zones. Typically, generation zones will be reviewed at the beginning of each price control period with another review only undertaken in exceptional circumstances. Any rezoning required during a price control period will be undertaken with the intention of minimal disruption to the established zonal boundaries. The full criteria for determining generation zones are outlined in paragraph 14.15.33. The number of generation zones set for 2010/11 is 20.

**Formatted:** Bullets and Numbering

**Deleted:** 26

**14.15.29** Demand zone boundaries have been fixed and relate to the GSP Groups used for energy market settlement purposes.

**Formatted:** Bullets and Numbering

**14.15.30** The nodal marginal km are amalgamated into zones by weighting them by their relevant generation or demand capacity.

**Formatted:** Bullets and Numbering

**14.15.31** Generators will have zonal tariffs derived from both the wider Peak Security nodal marginal km; and the wider Year Round nodal marginal km for the generation node, calculated as the increase or decrease in marginal km along all transmission circuits except those classified as local assets.

**Formatted:** Bullets and Numbering

**Deleted:** a

**Deleted:** tariff

The zonal Peak Security marginal km for generation is calculated as:

**Formatted:** Indent: Left: 1.27 cm, No bullets or numbering, Tabs: Not at 1.27

$$WNMkm_{j PS} = \frac{NMkm_{j PS} * Gen_j}{\sum_{j \in Gi} Gen_j}$$

**Deleted:**  $WNMkm_j = \frac{NMkm_j}{\sum_{j \in Gi} Gen_j}$

$$ZMkm_{Gi PS} = \sum_{j \in Gi} WNMkm_{j PS}$$

**Deleted:** ¶

**Deleted:**  $ZMkm_{Gi} = \sum_{j \in Gi} WNMkm_{j PS}$

Where

Gi = Generation zone

j = Node

NMkm<sub>PS</sub> = Peak Security Wider nodal marginal km from transport model

WNMkm<sub>PS</sub> = Peak Security Weighted nodal marginal km

ZMkm<sub>PS</sub> = Peak Security Zonal Marginal km

Gen<sub>j</sub> = Nodal Generation (scaled by the appropriate Peak Security Scaling factor) from the transport model

**Deleted:** . . .

**Deleted:** . = .

**Deleted:** . . .

**Formatted:** Indent: Left: 1.27 cm, Hanging: 3.81 cm

**Deleted:** . . .

**Deleted:** The

**Deleted:** demand zones are

**Deleted:** follows:¶

**Formatted:** Justified

Similarly, the zonal Year Round marginal km for generation is calculated as:

**Deleted:**  $WNMkm_j = \frac{NMkm_j}{\sum_{j \in Gi} Gen_j}$

$$WNMkm_{j YR} = \frac{NMkm_{j YR} * Gen_j}{\sum_{j \in Gi} Gen_j}$$

**Formatted:** Font: Arial (W1), 11 pt

$$ZMkm_{GiYR} = \sum_{j \in Gi} WNMkm_{jYR}$$

**Deleted:**  $ZMkm_{Di} = \sum_{j \in Di} Wl$

**Formatted:** Justified

Where

NMkm<sub>YR</sub> = Year Round Wider nodal marginal km from transport model

WNMkm<sub>YR</sub> = Year Round Weighted nodal marginal km

ZMkm<sub>YR</sub> = Year Round Zonal Marginal km

Gen = Nodal Generation (scaled by the appropriate Year Round Scaling factor) from the transport model

**Formatted:** Indent: Left: 1.27 cm, First line: 0 cm

14.15.32 The zonal Peak Security marginal km for demand zones are calculated as follows:

**Formatted:** Bullets and Numbering

$$WNMkm_{jPS} = \frac{-1 * NMkm_{jPS} * Dem_j}{\sum_{j \in Di} Dem_j}$$

$$ZMkm_{DiPS} = \sum_{j \in Di} WNMkm_{jPS}$$

Where:

Di = Demand zone

Dem = Nodal Demand from transport model

Similarly, the zonal Year Round marginal km for demand zones are calculated as follows:

**Formatted:** Indent: Left: 1.6 cm

$$WNMkm_{jYR} = \frac{-1 * NMkm_{jYR} * Dem_j}{\sum_{j \in Di} Dem_j}$$

$$ZMkm_{DiYR} = \sum_{j \in Di} WNMkm_{jYR}$$

14.15.33 A number of criteria are used to determine the definition of the generation zones. Whilst it is the intention of The Company that zones are fixed for the duration of a price control period, it may become necessary in exceptional circumstances to review the boundaries having been set. In both circumstances, the following criteria are used to determine the zonal boundaries:

**Formatted:** Bullets and Numbering

**Formatted:** Indent: Left: 2.75 cm, Numbered + Level: 1 + Numbering Style: i, ii, iii, ... + Start at: 1 + Alignment: Left + Aligned at: 0 cm + Tab after: 1.27 cm + Indent at: 0 cm, Tabs: 3.6 cm, List tab + Not at 1.27 cm

i.) Zoning is determined using the generation background with the most MWkm of circuits. Zones should contain relevant nodes whose total wider marginal costs from the relevant generation background (as determined from the output from the transport model, the relevant expansion constant and the locational security factor, see below) are all within +/-£1.00/kW (nominal prices) across the zone. This means a maximum spread of £2.00/kW in nominal prices across the zone.

**Formatted:** Indent: Left: 2.75 cm

**Formatted:** Indent: Left: 2.75 cm, Numbered + Level: 1 + Numbering Style: i, ii, iii, ... + Start at: 1 + Alignment: Left + Aligned at: 0 cm + Tab after: 1.27 cm + Indent at: 0 cm, Tabs: 3.6 cm, List tab + Not at 1.27 cm

ii.) The nodes within zones should be geographically and electrically proximate.

**Formatted:** Indent: Left: 2.75 cm

iii.) Relevant nodes are considered to be those with generation connected to them as these are the only ones, which contribute to the calculation of the zonal generation tariff.

**Formatted:** Indent: Left: 2.75 cm, Numbered + Level: 1 + Numbering Style: i, ii, iii, ... + Start at: 1 + Alignment: Left + Aligned at: 0 cm + Tab after: 1.27 cm + Indent at: 0 cm, Tabs: 3.6 cm, List tab + Not at 1.27 cm

**Deleted:** 26

**Formatted:** Bullets and Numbering

14.15.34 The process behind the criteria in 14.15.33 is driven by initially applying the nodal marginal costs from the relevant generation background within the DCLF Transport model onto the appropriate areas of a substation line diagram. Generation nodes are grouped into initial zones using the +/- £1.00/kW range. All nodes within each zone are then checked to ensure the geographically and electrically proximate criteria have been met using the substation line diagram. The established zones are inspected to ensure the least number of zones are used with minimal change from previously established zonal boundaries. The zonal boundaries are finally confirmed using the demand nodal costs from the relevant generation background for guidance.

14.15.35 The zoning criteria are applied to a reasonable range of DCLF ICRP transport model scenarios, the inputs to which are determined by The Company to create appropriate TNUoS generation zones. The minimum number of zones, which meet the stated criteria, are used. If there is more than one feasible zonal definition of a certain number of zones, The Company determines and uses the one that best reflects the physical system boundaries.

**Formatted:** Bullets and Numbering

14.15.36 Zones will typically not be reviewed more frequently than once every price control period to provide some stability. However, in exceptional circumstances, it may be necessary to review zoning more frequently to maintain appropriate, cost reflective, locational cost signals. For example, if a new generator connecting to the transmission system would cause the creation of a new generation zone for that generator alone, it may not be appropriate from a cost reflective perspective to wait until the next price control period to undertake this rezoning. If any such rezoning is required, it will be undertaken against a background of minimal change to existing generation zones and in line with the notification process set out in the Transmission Licence and CUSC.

**Formatted:** Bullets and Numbering

**Accounting for Sharing of Transmission by Generators**

**Formatted:** Indent: Left: 1.69 cm

14.15.37 A proportion of the marginal km costs for generation are shared incrementally reflecting the ability of differing generation technologies to share transmission investment. This is reflected in charges through the splitting of Year Round marginal km costs for generation into Year Round Shared marginal km costs and Year Round Not-Shared marginal km which are then used in the calculation of the wider £/kW generation tariff.

**Formatted:** Indent: Left: 1.9 cm, Numbered + Level: 1 + Numbering Style: 1, 2, 3, ... + Start at: 1 + Alignment: Left + Aligned at: 1.69 cm + Tab after: 1.69 cm + Indent at: 3.29 cm, Tabs: 1.9 cm, List tab + Not at 1.27 cm + 1.69

14.15.38 The sharing between different generation types is accounted for by (a) using transmission network boundaries between generation zones set by connectivity between generation charging zones, and (b) the proportion of Low Carbon and Carbon generation behind these boundaries.

**Formatted:** Indent: Left: 1.9 cm, Numbered + Level: 1 + Numbering Style: 1, 2, 3, ... + Start at: 1 + Alignment: Left + Aligned at: 1.69 cm + Tab after: 1.69 cm + Indent at: 3.29 cm, Tabs: 1.9 cm, List tab + Not at 1.27 cm + 1.69

14.15.39 The zonal incremental km for each generation charging zone is split into each boundary component by considering the difference between it and the neighbouring generation charging zone using the formula below:

**Formatted:** Indent: Left: 1.9 cm, Hanging: 1.69 cm, Numbered + Level: 1 + Numbering Style: 1, 2, 3, ... + Start at: 1 + Alignment: Left + Aligned at: 1.69 cm + Tab after: 1.69 cm + Indent at: 3.29 cm, Tabs: Not at 1.27 cm

$$BIkm_{ab} = ZIkm_b - ZIkm_a$$

Where:

BIkm<sub>ab</sub> = boundary incremental km between generation charging zone A and generation charging zone B

ZIkm = generation charging zone incremental km.

14.15.40 The table below shows the categorisation of Low Carbon and Carbon generation. This table will be updated by National Grid in the Statement of Use of System Charges as new generation technologies are developed.

Carbon	Low Carbon
Coal	Wind
Gas	Hydro (excl. Pumped Storage)
Biomass	Nuclear
Oil	Marine
Pumped Storage	Tidal
Interconnectors	

**Formatted:** Indent: Left: 1.9 cm, Hanging: 1.69 cm, Numbered + Level: 1 + Numbering Style: 1, 2, 3, ... + Start at: 1 + Alignment: Left + Aligned at: 1.69 cm + Tab after: 1.69 cm + Indent at: 3.29 cm, Tabs: Not at 1.69 cm

**Determination of Connectivity**

14.15.41 Connectivity is based on the existence of electrical circuits between TNUoS generation charging zones that are represented in the Transport model. Where such paths exist, generation charging zones will be effectively linked via an incremental km transmission boundary length. These paths will be simplified through in the case of:

**Formatted:** Indent: Left: 1.9 cm, Numbered + Level: 1 + Numbering Style: 1, 2, 3, ... + Start at: 1 + Alignment: Left + Aligned at: 1.69 cm + Tab after: 1.69 cm + Indent at: 3.29 cm, Tabs: Not at 1.27 cm

- Parallel paths – the longest path will be taken. An illustrative example is shown below with x, y and z representing the incremental km between zones.

**Formatted:** Indent: Left: 1.9 cm, Bulleted + Level: 1 + Aligned at: 0.63 cm + Tab after: 1.27 cm + Indent at: 1.27 cm, Tabs: 2.54 cm, List tab + Not at 1.27 cm

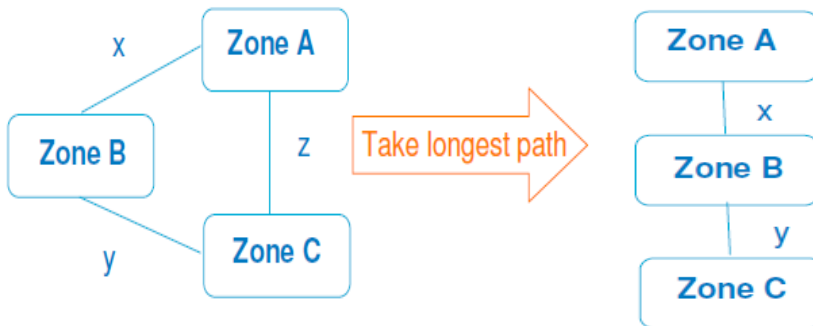

- Parallel zones – parallel zones will be amalgamated with the incremental km immediately beyond the amalgamated zones being the greater of those existing prior to the amalgamation. An illustrative example is shown below with a, b, c, and d representing the the initial incremental km between zones, and x and y representing the final incremental km following zonal amalgamation.

**Formatted:** Indent: Left: 1.9 cm, Bulleted + Level: 1 + Aligned at: 0.63 cm + Tab after: 1.27 cm + Indent at: 1.27 cm, Tabs: 2.54 cm, List tab + Not at 1.27 cm

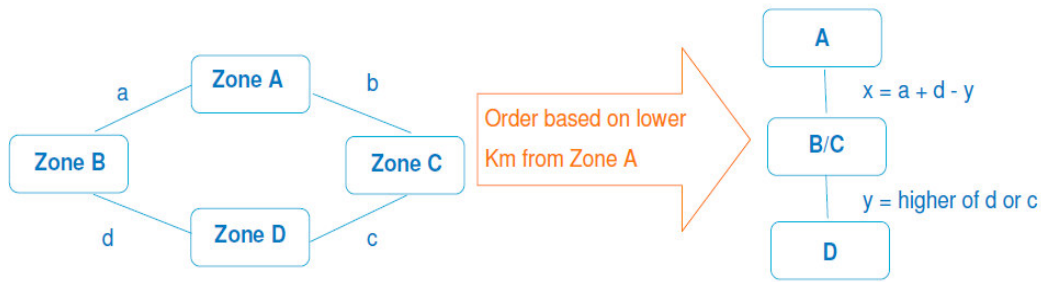

14.15.42 An illustrative Connectivity diagram is shown below:

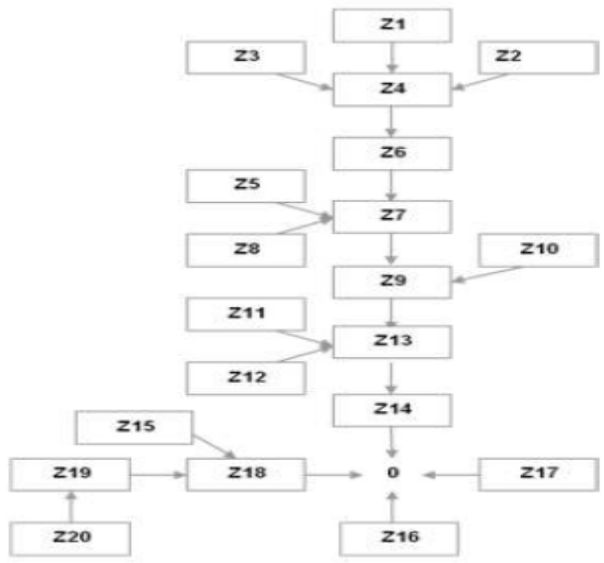

**Formatted:** Indent: Left: 1.9 cm, Numbered + Level: 1 + Numbering Style: 1, 2, 3, ... + Start at: 1 + Alignment: Left + Aligned at: 1.69 cm + Tab after: 1.69 cm + Indent at: 3.29 cm, Tabs: Not at 1.27 cm

The arrows connecting generation charging zones and amalgamated generation charging zones represent the incremental km transmission boundary lengths towards the notional centre of the system. Generation located in charging zones behind arrows is considered to share based on the ratio of Low Carbon to Carbon cumulative generation TEC within those zones.

14.15.43 The Company will review Connectivity at the beginning of a new price control period, and under exceptional circumstances such as major system reconfigurations or generation rezoning. If any such reassessment is required, it will be undertaken against a background of minimal change to existing Connectivity and in line with the notification process set out in the Transmission Licence and the CUSC.

**Formatted:** Indent: Left: 1.27 cm, Numbered + Level: 1 + Numbering Style: 1, 2, 3, ... + Start at: 1 + Alignment: Left + Aligned at: 1.69 cm + Tab after: 1.69 cm + Indent at: 3.29 cm, Tabs: Not at 1.69 cm

**Deleted:**

**Calculation of Boundary Sharing Factors**

14.15.44 Boundary sharing factors (BSFs) are derived from the comparison of the cumulative proportion of Low Carbon and Carbon generation TEC behind each of the incremental MWkm boundary lengths using the following formulae –

**Formatted:** Indent: Left: 1.27 cm, Numbered + Level: 1 + Numbering Style: 1, 2, 3, ... + Start at: 1 + Alignment: Left + Aligned at: 1.69 cm + Tab after: 1.69 cm + Indent at: 3.29 cm, Tabs: Not at 1.69 cm

**Formatted:** Indent: Left: 1.27 cm

If  $\frac{LC}{LC+C} \leq 0.5$ , then all Year round marginal km costs are shared i.e. the BSF is 100%.

Where:

LC = Cumulative Low Carbon generation TEC behind the relevant transmission boundary

C = Cumulative Carbon generation TEC behind the relevant transmission boundary

If  $\frac{LC}{LC+C} > 0.5$  then the BSF is calculated using the following formula: -

$$BSF = \left( -2 \times \left( \frac{LC}{LC+C} \right) \right) + 2$$

Where:

BSF = boundary sharing factor.

14.15.45 The shared incremental km for each boundary are derived from the multiplication of the boundary sharing factor by the incremental km for that boundary:

$$SBIkm_{ab} = BIIkm_{ab} \times BSF_{ab}$$

Where:

SBIkm<sub>ab</sub> = shared boundary incremental km between generation charging zone A and generation charging zone B

BSF<sub>ab</sub> = generation charging zone boundary sharing factor.

**Formatted:** Indent: Left: 1.27 cm, Numbered + Level: 1 + Numbering Style: 1, 2, 3, ... + Start at: 1 + Alignment: Left + Aligned at: 1.69 cm + Tab after: 1.69 cm + Indent at: 3.29 cm, Tabs: Not at 1.69 cm

14.15.46 The shared incremental km is discounted from the incremental km for that boundary to establish the not-shared boundary incremental km. The not-shared boundary incremental km reflects the cost of transmission investment on that boundary accounting for the sharing of power stations behind that boundary.

$$NSBIkm_{ab} = BIIkm_{ab} - SBIkm_{ab}$$

Where:

NSBIkm<sub>ab</sub> = not shared boundary incremental km between generation charging zone A and generation charging zone B.

**Formatted:** Indent: Left: 1.27 cm, Numbered + Level: 1 + Numbering Style: 1, 2, 3, ... + Start at: 1 + Alignment: Left + Aligned at: 1.69 cm + Tab after: 1.69 cm + Indent at: 3.29 cm, Tabs: Not at 1.69 cm

14.15.47 The shared incremental km for a generation charging zone is the sum of the appropriate shared boundary incremental km for that generation charging zone as derived from the connectivity diagram.

$$\sum_a^n NSBIkm_{ab} = ZMkm_{nYRS}$$

Where:

ZMkm<sub>nYRS</sub> = Year Round Shared Zonal Marginal km for generation charging zone n.

**Formatted:** Indent: Left: 1.27 cm, Numbered + Level: 1 + Numbering Style: 1, 2, 3, ... + Start at: 1 + Alignment: Left + Aligned at: 1.69 cm + Tab after: 1.69 cm + Indent at: 3.29 cm, Tabs: Not at 1.69 cm

14.15.48 The not-shared incremental km for a generation charging zone is the sum of the appropriate not-shared boundary incremental km for that generation charging zone as derived from the connectivity diagram.

**Formatted:** Indent: Left: 1.27 cm, Numbered + Level: 1 + Numbering Style: 1, 2, 3, ... + Start at: 1 + Alignment: Left + Aligned at: 1.69 cm + Tab after: 1.69 cm + Indent at: 3.29 cm, Tabs: Not at 1.69 cm

$$\sum_a^n NSBIkm_{ab} = ZMkm_{nYRNS}$$

Where:

$ZMkm_{nYRNS}$  = Year Round Not-Shared Zonal Marginal km for generation zone n.

Formatted: Indent: Left: 1.69 cm

### Deriving the Final Local £/kW Tariff and the Wider £/kW Tariff

14.15.49 The zonal marginal km ( $ZMkm_{Gi}$ ) are converted into costs and hence a tariff by multiplying by the **Expansion Constant** and the **Locational Security Factor** (see below). The nodal local marginal km ( $NLMkm^L$ ) are converted into costs and hence a tariff by multiplying by the **Expansion Constant** and a **Local Security Factor**.

Formatted: Bullets and Numbering

### The Expansion Constant

14.15.50 The expansion constant, expressed in £/MWkm, represents the annuitised value of the transmission infrastructure capital investment required to transport 1 MW over 1 km. Its magnitude is derived from the projected cost of 400kV overhead line, including an estimate of the cost of capital, to provide for future system expansion.

Formatted: Bullets and Numbering

14.15.51 In the methodology, the expansion constant is used to convert the marginal km figure derived from the transport model into a £/MW signal. The tariff model performs this calculation, in accordance with 14.15.82 – 14.15.104, and also then calculates the residual element of the overall tariff (to ensure correct revenue recovery in accordance with the price control), in accordance with 14.15.120.

Formatted: Bullets and Numbering

Deleted: 60

Deleted: 65

Deleted: 8

Deleted: 1.

Formatted: Bullets and Numbering

14.15.52 The transmission infrastructure capital costs used in the calculation of the expansion constant are provided via an externally audited process. They also include information provided from all onshore Transmission Owners (TOs). They are based on historic costs and tender valuations adjusted by a number of indices (e.g. global price of steel, labour, inflation, etc.). The objective of these adjustments is to make the costs reflect current prices, making the tariffs as forward looking as possible. This cost data represents The Company's best view; however it is considered as commercially sensitive and is therefore treated as confidential. The calculation of the expansion constant also relies on a significant amount of transmission asset information, much of which is provided in the Seven Year Statement.

Formatted: Bullets and Numbering

Deleted: 42

Deleted: 47

Formatted: Bullets and Numbering

Formatted

Formatted

Formatted

Formatted

Formatted

Formatted

Formatted

Formatted

Formatted

Formatted

Formatted

Formatted

Formatted

Formatted

Formatted

Formatted

Formatted

Formatted

Formatted

Formatted

14.15.53 For each circuit type and voltage used onshore, an individual calculation is carried out to establish a £/MWkm figure, normalised against the 400KV overhead line (OHL) figure, these provide the basis of the onshore circuit expansion factors discussed in 14.15.61 – 14.15.68. In order to simplify the calculation a unity power factor is assumed, converting £/MVAkm to £/MWkm. This reflects that the fact tariffs and charges are based on real power.

14.15.54 The table below shows the first stage in calculating the onshore expansion constant. A range of overhead line types is used and the types are weighted by recent usage on the transmission system. This is a simplified calculation for 400kV OHL using example data:

400kV OHL expansion constant calculation						
MW	Type	£(000)/km	Circuit km*	£/MWkm	Weight	
A	B	C	D	E = C/A	F=E*D	
6500	La	700	500	107.69	53846	



6500	Lb	780	0	120.00	0
3500	La/b	600	200	171.43	34286
3600	Lc	400	300	111.11	33333
4000	Lc/a	450	1100	112.50	123750
5000	Ld	500	300	100.00	30000
5400	Ld/a	550	100	101.85	10185
<b>Sum</b>		<b>2500 (G)</b>		<b>285400 (H)</b>	
				<b>Weighted Average (J= H/G):</b>	
				<b>114.160 (J)</b>	

\*These are circuit km of types that have been provided in the previous 10 years. If no information is available for a particular category the best forecast will be used.

14.15.55 The weighted average £/MWkm (J in the example above) is then converted in to an annual figure by multiplying it by an annuity factor. The formula used to calculate of the annuity factor is shown below:

$$Annuity\ factor = \frac{1}{\left[ \frac{1 - (1 + WACC)^{-Asset\ Life}}{WACC} \right]}$$

14.15.56 The Weighted Average Cost of Capital (WACC) and asset life are established at the start of a price control and remain constant throughout a price control period. The WACC used in the calculation of the annuity factor is the The Company regulated rate of return, this assumes that it will be reasonably representative of all licensees. The asset life used in the calculation is 50 years; the appropriateness of this is reviewed when the annuity factor is recalculated at the start of a price control period. These assumptions provide a current annuity factor of 0.066.

14.15.57 The final step in calculating the expansion constant is to add a share of the annual transmission overheads (maintenance, rates etc). This is done by multiplying the average weighted cost (J) by an ‘overhead factor’. The ‘overhead factor’ represents the total business overhead in any year divided by the total Gross Asset Value (GAV) of the transmission system. This is recalculated at the start of each price control period. The overhead factor used in the calculation of the expansion constant for 2009/10 is 1.8%. The overhead and annuitised costs are then added to give the expansion constant.

14.15.58 Using the previous example, the final steps in establishing the expansion constant are demonstrated below:

400kV OHL expansion constant calculation	Ave £/MWkm
<b>OHL</b>	114.160
Annuitised	7.535
Overhead	2.055
<b>Final</b>	<b>9.589</b>

14.15.59 This process is carried out for each voltage onshore, along with other adjustments to take account of upgrade options, see 14.15.64, and normalised against the 400KV

Formatted ... [10]

Formatted ... [11]

Formatted ... [12]

Formatted ... [13]

Formatted ... [14]

Formatted ... [15]

Formatted

Formatted: Font: 11 pt

Formatted

Formatted: Font: 11 pt

Formatted

Formatted: Font: 11 pt

Formatted

Formatted: Font: 11 pt

Formatted

Formatted: Font: 11 pt

Formatted

Formatted: Font: 11 pt

Formatted: Bullets and Numbering

Formatted: Bullets and Numbering

Formatted: Bullets and Numbering

Formatted: Bullets and Numbering

Formatted: Bullets and Numbering

Deleted: 45

overhead line cost (the expansion constant) the resulting ratios provide the basis of the onshore expansion factors. The process used to derive circuit expansion factors for Offshore Transmission Owner networks is described in 14.15.69.

Deleted: 50

**14.15.60** This process of calculating the incremental cost of capacity for a 400kV OHL, along with calculating the onshore expansion factors is carried out for the first year of the price control and is increased by inflation, RPI, (May–October average increase, as defined in The Company’s Transmission Licence) each subsequent year of the price control period. The expansion constant for 2010/11 is 10.633.

Formatted: Bullets and Numbering

**Onshore Wider Circuit Expansion Factors**

**14.15.61** Base onshore expansion factors are calculated by deriving individual expansion constants for the various types of circuit, following the same principles used to calculate the 400kV overhead line expansion constant. The factors are then derived by dividing the calculated expansion constant by the 400kV overhead line expansion constant. The factors will be fixed for each respective price control period.

Formatted: Bullets and Numbering

**14.15.62** In calculating the onshore underground cable factors, the forecast costs are weighted equally between urban and rural installation, and direct burial has been assumed. The operating costs for cable are aligned with those for overhead line. An allowance for overhead costs has also been included in the calculations.

Formatted: Bullets and Numbering

**14.15.63** The 132kV onshore circuit expansion factor is applied on a TO basis. This is to reflect the regional variation of plans to rebuild circuits at a lower voltage capacity to 400kV. The 132kV cable and line factor is calculated on the proportion of 132kV circuits likely to be uprated to 400kV. The 132kV expansion factor is then calculated by weighting the 132kV cable and overhead line costs with the relevant 400kV expansion factor, based on the proportion of 132kV circuitry to be uprated to 400kV. For example, in the TO areas of National Grid and Scottish Power where there are no plans to uprate any 132kV circuits, the full cable and overhead line costs of 132kV circuit are reflected in the 132kV expansion factor calculation.

Formatted: Bullets and Numbering

**14.15.64** The 275kV onshore circuit expansion factor is applied on a GB basis and includes a weighting of 83% of the relevant 400kV cable and overhead line factor. This is to reflect the averaged proportion of circuits across all three Transmission Licensees which are likely to be uprated from 275kV to 400kV across GB within a price control period.

Formatted: Bullets and Numbering

**14.15.65** The 400kV onshore circuit expansion factor is applied on a GB basis and reflects the full costs for 400kV cable and overhead lines.

Formatted: Bullets and Numbering

**14.15.66** AC sub-sea cable and HVDC circuit expansion factors are calculated on a case by case basis using actual project costs (Specific Circuit Expansion Factors).

Formatted: Bullets and Numbering

**14.15.67** For HVDC circuit expansion factors both the cost of the converters and the cost of the cable are included in the calculation.

Formatted: Bullets and Numbering

**14.15.68** The TO specific onshore circuit expansion factors calculated for 2008/9 (and rounded to 2 decimal places) are:

Formatted: Bullets and Numbering

Scottish Hydro Region

400kV <u>underground</u> cable factor:	22.39
275kV <u>underground</u> cable factor:	22.39
132kV <u>underground</u> cable factor:	27.79
400kV line factor:	1.00

275kV line factor: 1.14  
 132kV line factor: 2.24

Scottish Power & National Grid Regions

400kV underground cable factor: 22.39  
 275kV underground cable factor: 22.39  
 132kV underground cable factor: 30.22  
 400kV line factor: 1.00  
 275kV line factor: 1.14  
 132kV line factor: 2.80

**Onshore Local Circuit Expansion Factors**

**14.15.69** The local onshore circuit tariff is calculated using local onshore circuit expansion factors. These expansion factors are calculated using the same methodology as the onshore wider expansion factor but without taking into account the proportion of circuit kms that are planned to be uprated.

**Formatted:** Bullets and Numbering

**14.15.70** In addition, the 132kV onshore overhead line circuit expansion factor is sub divided into four more specific expansion factors. This is based upon maximum (winter) circuit continuous rating (MVA) and route construction whether double or single circuit.

**Formatted:** Bullets and Numbering

400kV underground cable factor: 22.39  
 275kV underground cable factor: 22.39  
 132kV underground cable factor: 30.22  
 400kV line factor: 1.00  
 275kV line factor: 1.14

132kV line factor (single; <200MVA): 10.00  
 132kV line factor (double; <200MVA): 8.32  
 132kV line factor (single; >=200MVA): 7.13  
 132kV line factor (double; >=200MVA): 4.42

**Offshore Circuit Expansion Factors**

**14.15.71** Offshore expansion factors (£/MWkm) are derived from information provided by Offshore Transmission Owners for each offshore circuit. Offshore expansion factors are Offshore Transmission Owner and circuit specific. Each Offshore Transmission Owner will periodically provide, via the STC, information to derive an annual circuit revenue requirement. The offshore circuit revenue shall include revenues associated with the Offshore Transmission Owner’s reactive compensation equipment, harmonic filtering equipment, asset spares and HVDC converter stations.

**Formatted:** Bullets and Numbering

**14.15.72** In the first year of connection, the offshore circuit expansion factor would be calculated as follows:

**Formatted:** Bullets and Numbering

$$\frac{CRevOFTO1}{L \times CircRat} \div \text{Onshore 400kV OHL Expansion Constant}$$

Where:

CRevOFTO1 = The offshore circuit revenue in £ for Year 1  
 L = The total circuit length in km of the offshore circuit  
 CircRat = The continuous rating of the offshore circuit

**14.15.73** In all subsequent years, the offshore circuit expansion factor would be calculated as follows:

**Formatted:** Bullets and Numbering

$$\frac{AvCRevOFTO}{L \times CircRat} \div \text{Onshore 400kV OHL Expansion Constant}$$

Where:

- AvCRevOFTO = The annual offshore circuit revenue averaged over the remaining years of the onshore National Electricity Transmission System Operator (NETSO) price control
- L = The total circuit length in km of the offshore circuit
- CircRat = The continuous rating of the offshore circuit

**14.15.74** Prevailing OFFSHORE TRANSMISSION OWNER specific expansion factors will be published in this statement. These shall be re-calculated at the start of each price control when the onshore expansion constants are revisited.

**Formatted:** Bullets and Numbering

**Formatted:** 1,2,3, Indent: First line: 0 cm

**The Locational Onshore Security Factor**

**14.15.75** The locational onshore security factor is derived by running a secure DCLF ICRP transport study based on the same market background as used for Zoning in the DCLF ICRP transport model. This calculates the nodal marginal costs where peak demand can be met despite the Security and Quality of Supply Standard contingencies (simulating single and double circuit faults) on the network. Essentially the calculation of secured nodal marginal costs is identical to the process outlined above except that the secure DCLF study additionally calculates a nodal marginal cost taking into account the requirement to be secure against a set of worse case contingencies in terms of maximum flow for each circuit.

**Formatted:** Bullets and Numbering

**14.15.76** The secured nodal cost differential is compared to that produced by the DCLF ICRP transport model and the resultant ratio of the two determines the locational security factor using the Least Squares Fit method. Further information may be obtained from the charging website<sup>1</sup>.

**Formatted:** Bullets and Numbering

**14.15.77** The locational onshore security factor derived for 2010/11 is 1.8 and is based on an average from a number of studies conducted by The Company to account for future network developments. The security factor is reviewed for each price control period and fixed for the duration.

**Formatted:** Bullets and Numbering

**Local Security Factors**

**14.15.78** Local onshore security factors are generator specific and are applied to a generators local onshore circuits. If the loss of any one of the local circuits prevents the export of power from the generator to the MITS then a local security factor of 1.0 is applied. For generation with circuit redundancy, a local security factor is applied that is equal to the locational security factor, currently 1.8.

**Formatted:** Bullets and Numbering

**14.15.79** Where a Transmission Owner has designed a local onshore circuit (or otherwise that circuit once built) to a capacity lower than the aggregated TEC of the generation using that circuit, then the local security factor of 1.0 will be multiplied by a Counter Correlation Factor (CCF) as described in the formula below:

**Formatted:** Bullets and Numbering

<sup>1</sup> <http://www.nationalgrid.com/uk/Electricity/Charges/>

$$CCF = \frac{D_{min} + T_{cap}}{G_{cap}}$$

Where:  $D_{min}$  = minimum annual net demand (MW) supplied via that circuit in the absence of that generation using the circuit

$T_{cap}$  = transmission capacity built (MVA)

$G_{cap}$  = aggregated TEC of generation using that circuit

CCF cannot be greater than 1.0.

Formatted: Font: Arial

Formatted: Font: Arial, 11 pt

14.15.80 A specific offshore local security factor (LocalSF) will be calculated for each offshore connection using the following methodology:

Formatted: Bullets and Numbering

$$LocalSF = \frac{NetworkExportCapacity}{\sum_k Gen_k}$$

Where:

NetworkExportCapacity = the total export capacity of the network  
 k = the generation connected to the offshore network

14.15.81 The offshore security factor for single circuits with a single cable will be 1.0 and for multiple circuit connections will be capped at the locational onshore security factor, derived as 1.8 for 2010/11.

Formatted: Bullets and Numbering

Formatted: Indent: Left: 1.27 cm

### Initial Transport Tariff

14.15.82 First an Initial Transport Tariff (ITT) must be calculated for both Peak Security and Year Round backgrounds. For Generation, the Peak Security zonal marginal km ( $ZMkm_{PS}$ ), Year Round Not-Shared zonal marginal km ( $ZMkm_{YRNS}$ ) and Year Round Shared zonal marginal km ( $ZMkm_{YRS}$ ) are simply multiplied by the expansion constant and the locational security factor to give the Peak Security ITT, Year Round Not-Shared ITT and Year Round Shared ITT respectively:

Formatted: Bullets and Numbering

Deleted: initial transport tariff

Formatted: Highlight

Formatted: Highlight

Deleted:  $ZMkm_{Gi} \times EC \times L$

Formatted: Highlight

$$ZMkm_{Gi PS} \times EC \times LSF = ITT_{Gi PS}$$

$$ZMkm_{Gi YRNS} \times EC \times LSF = ITT_{Gi YRNS}$$

$$ZMkm_{Gi YRS} \times EC \times LSF = ITT_{Gi YRS}$$

Deleted: = .

Formatted: Highlight

Formatted: Indent: Left: 1.27 cm, Tabs: Not at 2 cm + 2.5 cm + 3 cm

Formatted: Highlight

Formatted: Highlight

Formatted: Highlight

Formatted: Highlight

Formatted: Highlight

Formatted: Highlight

Deleted: ¶

Where

$ZMkm_{Gi PS}$  = Peak Security Zonal Marginal km for each generation zone

$ZMkm_{Gi YRNS}$  = Year Round Not-Shared Zonal Marginal km for each generation charging zone

$ZMkm_{Gi YRS}$  = Year Round Shared Zonal Marginal km for each generation charging zone

EC = Expansion Constant

LSF = Locational Security Factor

~~ITT<sub>GiPS</sub> = Peak Security Initial Transport Tariff (£/MW) for each generation zone~~

~~ITT<sub>GiYRNS</sub> = Year Round Not-Shared Initial Transport Tariff (£/MW) for each generation charging zone~~

~~ITT<sub>GiYRS</sub> = Year Round Shared Initial Transport Tariff (£/MW) for each generation charging zone.~~

14.15.83 Similarly, for demand the Peak Security zonal marginal km (ZMkm<sub>ps</sub>) and Year Round zonal marginal km (ZMkm<sub>YR</sub>) are simply multiplied by the expansion constant and the locational security factor to give the Peak Security ITT and Year Round ITT respectively:

$$ZMkm_{DiPS} \times EC \times LSF = ITT_{DiPS}$$

$$ZMkm_{DiYR} \times EC \times LSF = ITT_{DiYR}$$

Where

~~ZMkm<sub>DiPS</sub> = Peak Security Zonal Marginal km for each demand zone~~

~~ZMkm<sub>DiYR</sub> = Year Round Zonal Marginal km for each demand zone~~

~~ITT<sub>DiPS</sub> = Peak Security Initial Transport Tariff (£/MW) for each demand zone~~

~~ITT<sub>DiYR</sub> = Year Round Initial Transport Tariff (£/MW) for each demand zone~~

14.15.84 The next step is to multiply these ITTs by the expected metered triad demand and generation capacity to gain an estimate of the initial revenue recovery for both Peak Security and Year Round backgrounds. The metered triad demand and generation capacity are based on forecasts provided by Users and are confidential.

14.15.85 In addition, the initial tariffs for generation are also multiplied by the Peak Security flag when calculating the initial revenue recovery component for the Peak Security background. Similarly, when calculating the initial revenue recovery for the Shared component of the Year Round background, the initial tariffs are multiplied by the Annual Load Factor (see below).

14.15.86

~~Deleted: . ITT<sub>Gi</sub> . = .~~

Formatted: Highlight

Formatted: Indent: Left: 1.27 cm

Formatted: Highlight

Formatted: Highlight

Formatted: Highlight

Formatted: Highlight

Formatted: Highlight

Formatted: Highlight

Formatted: Indent: Left: 1.27 cm

Formatted: Bullets and Numbering

~~Deleted: initial transport tariff~~

~~Deleted: ZMkm<sub>Di</sub> × EC × I~~

~~Deleted: . = .~~

~~Deleted: EC . . = . Expansion Constant~~

~~Deleted: LSF . . = . Locational Security Factor~~

Formatted: Indent: Left: 1.27 cm, First line: 0 cm

~~Deleted: . ITT<sub>Di</sub> . = .~~

Formatted: Indent: Left: 1.27 cm

Formatted: Bullets and Numbering

~~Deleted: initial transport tariffs~~

~~Deleted: . Both of these latter parameters~~

Formatted: Font: Arial (W1), 11 pt

Formatted: Indent: Left: 1.27 cm

~~Deleted: .~~

$$\sum_{Gi=1}^{21} (ITT_{Gi} \times G_{Gi}) = ITRR_G$$

and

$$\sum_{Di=1}^{14} (ITT_{Di} \times D_{Di}) = ITRR_I$$

Formatted ... [16]

Formatted ... [17]

~~Deleted: for~~

Formatted ... [18]

~~Deleted: <#>¶~~ ... [19]

Formatted: Bullets and Numbering ... [20]

**Peak Security (PS) Flag**

14.15.87 The revenue from a specific generator due to the Peak Security locational tariff needs to be multiplied by the appropriate Peak Security (PS) flag. The PS flags indicate the extent to which a generation plant type contributes to the need for transmission network investment at peak demand conditions. The PS flag is derived from the contribution of differing generation sources to the demand security criterion as described in the Security Standard. In the event of a significant change to the demand security assumptions in the Security Standard, National Grid will review the use of the PS flag.

**Formatted:** Bullets and Numbering

Generation Plant Type	PS flag
Intermittent	0
Other	1

**Annual Load Factor (ALF)**

14.14.87 The ALF for each individual Power Station is calculated using the relevant TEC (MW) and corresponding output data. Where output data is not available for a Power Station, including for new Power Stations and emerging Power Station technologies, generic data for the appropriate generation plant type will be used.

**Deleted:** The  
**Formatted:** 1,2,3, Justified, Numbered + Level: 1 + Numbering Style: 1, 2, 3, ... + Start at: 87 + Alignment: Left + Aligned at: 1.27 cm + Tab after: 1.27 cm + Indent at: 2.87 cm

14.15.88 For a given charging year “t” the Power Station ALF will be based on information from the previous five charging years, calculated for each charging year as set out below.

$$ALF = \frac{\sum_{p=1}^{17520} GMWh_p}{\sum_{p=1}^{17520} TEC_p \times 0.5}$$

**Deleted:** ALF for each individual Power Station is calculated using the relevant TEC and corresponding output data. Where output data is not available for a power station, including for new and emerging technologies, generic data for the appropriate generation plant type will be used.

**Formatted:** Font: Arial (W1)

**Formatted:** Font: Arial (W1)

**Deleted:** . ITRR<sub>G</sub> . . = .

**Formatted:** Bullets and Numbering

Where:

GMWh<sub>p</sub> is the maximum of FPN or actual metered output in a Settlement Period related to the power station TEC (MW); and

TEC<sub>p</sub> is the TEC (MW) applicable to that Power Station for that Settlement Period including any STTEC and LDTEC, accounting for any trading of TEC.

14.15.89 The appropriate output (FPN or actual metered) figure is derived from BM Unit data available to National Grid and relates to the total TEC of the Power Station.

**Formatted:** Bullets and Numbering

14.15.90 Once all five charging year ALFs have been calculated for the individual Power Station they are compared, and the highest and lowest figures are discarded. The final ALF, to be used for transmission charging purposes, is calculated as the average of the remaining three ALFs.

**Deleted:** balancing mechanism user

**Formatted:** Bullets and Numbering

14.15.91 In the event that only four charging years of complete output (FPN or actual metered) data are available for an individual Power Station then the higher three charging years ALF would be used in the calculation of the final ALF. In the event that only three charging years of complete output (FPN or actual metered) data are available then these three charging years would be used.

**Formatted:** Bullets and Numbering

14.15.92 Due to the aggregation of output (FPN or actual metered) data for dispersed generation (e.g. cascade hydro schemes), where a single generator BMU consists of geographically separated power stations, the ALF would be calculated based on the total output of the BMU and the overall TEC of those Power Stations .

**Formatted:** Bullets and Numbering

14.15.93 In the event that there are not three full charging years of an individual power station's output available, missing output (FPN or actual metered) data would be replaced by generic data for that generation plant type to ensure three charging years of information are available for the Power Station. The derivation of the generic data is described in paragraphs 14.15.97-14.15.100.

**Formatted:** Bullets and Numbering

14.15.94 Users will receive draft ALFs before 25<sup>th</sup> December of the charging year (t-1) for the charging year (t) and will have a period of 15 working days from date of publishing to notify the Company of any errors. Failure to agree changes relating to errors will be treated as a charging dispute under the CUSC.

**Deleted:** 82

**Deleted:** 85

**Formatted:** Indent: Left: 1.27 cm, Numbered + Level: 1 + Numbering Style: 1, 2, 3, ... + Start at: 1 + Alignment: Left + Aligned at: 1.69 cm + Tab after: 1.69 cm + Indent at: 3.29 cm, Tabs: Not at 1.69 cm

14.15.95 The ALFs used in the setting of final tariffs will be published in the annual Statement of Use of System Charges. Changes to ALFs after this publication will not result in changes to published tariffs (e.g. following dispute resolution).

**Formatted:** Indent: Left: 1.27 cm, Numbered + Level: 1 + Numbering Style: 1, 2, 3, ... + Start at: 1 + Alignment: Left + Aligned at: 1.69 cm + Tab after: 1.69 cm + Indent at: 3.29 cm, Tabs: Not at 1.69 cm

**Derivation of Generic ALFs**

14.15.96 The generic ALF is derived from the average annual output of the ten most recently commissioned GB generation of a particular generation plant type that have at least five charging years' data, using an identical methodology to that used for the Power Station specific calculation described above. Where less than ten GB generators of a particular generation plant type exist, then data from all existing generators of that particular generation plant type will be used. Example generation plant type categories are listed below:

**Deleted:** All Power Station ALFs are published in the Statement of Use of System Charges.¶

**Formatted:** Bullets and Numbering

<b>Fuel Type</b>
Biomass
Coal
Gas
Hydro
Nuclear (by reactor type)
Oil & OCGTs
Pumped Storage
Onshore Wind
Offshore Wind
CHP

14.15.97 The Company will keep these categories under review and update as necessary. Where within a category there is a significant locational difference consideration will be given to zonal generic factors. The factors used will be published in the Statement of Use of System Charges and will be reviewed annually.

**Formatted:** Bullets and Numbering

14.15.98 If a User can demonstrate that the generation plant type of a Power Station has changed, consideration will be given to the use of relevant generic ALF information in the calculation of their charges until sufficient specific data is available.

**Formatted:** Bullets and Numbering

**Deleted:** u

14.15.99 For new and emerging generation plant types, where insufficient data is available to allow a generic ALF to be developed, The Company will use the best information available e.g. from manufactures and data from use of similar technologies outside

**Formatted:** Bullets and Numbering



GB. The factor will be agreed with the relevant Generator. In the event of a disagreement the standard provisions for dispute in the CUSC will apply.

**Initial Revenue Recovery**

14.15.100 For the Peak Security background the initial tariff for generation is multiplied by the total forecast generation capacity and the PS flag to give the initial revenue recovery:

**Formatted:** Bullets and Numbering

$$\sum_{Gi=1}^n (ITT_{GiPS} \times G_{Gi} \times F_{PS}) = ITRR_{GPS}$$

Where

ITRR<sub>GPS</sub> = Peak Security Initial Transport Revenue Recovery for generation  
G<sub>Gi</sub> = Total forecast Generation for each generation zone (based on confidential User forecasts)  
F<sub>PS</sub> = Peak Security flag appropriate to that generator type  
n = Number of generation zones

**Formatted:** 1,2,3, Justified

**Formatted:** Font: Arial (W1)

**Deleted:** . ITRR<sub>b</sub> . = .

The initial revenue recovery for demand for the Peak Security background is calculated by multiplying the initial tariff by the total forecast metered triad demand:

$$\sum_{Di=1}^{14} (ITT_{DiPS} \times D_{Di}) = ITRR_{DPS}$$

Where:

ITRR<sub>DPS</sub> = Peak Security Initial Transport Revenue Recovery for demand  
D<sub>Di</sub> = Total forecast Metered Triad Demand for each demand zone (based on confidential User forecasts)

**Formatted:** Font: Arial (W1), 11 pt

**Formatted:** Indent: Left: 1.27 cm

**Deleted:** <#>The next stage is to correct the Initial Transport Revenue Recovery figures above such that the 'correct' split of revenue between generation and demand is obtained. This has been determined to be 27:73 by the Authority for generation and demand respectively. In order to achieve the 'correct' generation/demand revenue split, a single additive constant C is calculated which is then added to the total zonal marginal km, both for generation and demand as below: ¶ <#>¶

**Formatted:** Bullets and Numbering

**Formatted:** Highlight

**Deleted:**  $\sum_{Gi=1}^{21} [(ZMkm_{Gi} + C$

$\sum_{Di=1}^{14} [(ZMkm_{Di} - C) \times EC \times$

¶ Where C is set such that ¶ ¶

**Formatted:** Highlight

**Formatted:** Indent: Left: 1.27 cm

**Formatted:** Highlight

**Formatted:** Highlight

**Formatted:** Bullets and Numbering

14.15.101 For the Year Round background, the initial tariff for generation is multiplied by the total forecast generation capacity whilst calculating Initial Recovery for Not-Shared component whereas the initial tariff for Shared component is multiplied by both, the total forecast generation capacity and the ALF to give the initial revenue recovery:

$$\sum_{Gi=1}^n (ITT_{GiYRNS} \times G_{Gi}) = ITRR_{GYRNS}$$

$$\sum_{Gi=1}^n (ITT_{GiYRS} \times G_{Gi} \times ALF) = ITRR_{GYRS}$$

Where:

ITRR<sub>GYRNS</sub> = Year Round Not-Shared Initial Transport Revenue Recovery for generation  
ITRR<sub>GYRS</sub> = Year Round Shared Initial Transport Revenue Recovery for generation  
ALF = Annual Load Factor appropriate to that generator.

14.15.102 Similar to the Peak Security background, the initial revenue recovery for demand for the Year Round background is calculated by multiplying the initial tariff by the total forecast metered triad demand:

$$\sum_{Di=1}^{14} (ITT_{D_{iYR}} \times D_{Di}) = ITRR_{D_{iYR}}$$

Where:

$ITRR_{D_{iYR}}$  = Year Round Initial Transport Revenue Recovery for demand

**Deriving the Final Local Tariff (£/kW)**

**Local Circuit Tariff**

**14.15.103** Generation with a local circuit tariff is calculated by multiplying the Year Round nodal marginal km along the local circuit by the expansion constant and the relevant local security factor (whether onshore or offshore) and summing across local circuits to give the local circuit tariff:

$$\sum_k \frac{NLMkm_{G_j^L} \times EC \times LocalSF_k}{1000} = CLT_{G_i}$$

- Where
- $k$  = Local circuit  $k$  for generator
- $NLMkm_{G_j^L}$  = Year Round Nodal marginal km along local circuit  $k$  using local circuit expansion factor.
- $EC$  = Expansion Constant
- $LocalSF_k$  = Local Security Factor for circuit  $k$
- $CLT_{G_i}$  = Circuit Local Tariff (£/kW)

**Onshore Local Substation Tariff**

**14.15.104** All chargeable generation is subject to the local substation tariff component which is determined by assessing the generation substation type which is the substation at the connection charging boundary, against three cost determining factors:

- (a) HV connection voltage – the voltage at the boundary between the User’s connection assets and the transmission system;
- (b) Sum of TEC at the generation substation – the combined TEC of all generation at the connecting substation; and
- (c) The level of redundancy at the generation substation – single busbar / single switch mesh connections are examples of no redundancy connections, whereas examples of connections with redundancy include double busbar and mesh sub station designs.

**14.15.105** Using the above factors, the corresponding £/kW tariffs (quoted to 3dp) that will be applied during 2010/11 are:

Substation Rating (b)	Connection Type (c)	Substation Voltage (a)		
		132kV	275kV	400kV
<1320MW	No redundancy	0.133	0.081	0.065
<1320MW	Redundancy	0.301	0.192	0.155
>=1320MW	No redundancy	n/a	0.257	0.208
>=1320MW	Redundancy	n/a	0.417	0.336

**Deleted:**  $CTRR_D = p(CTT_{D_i})$

**Deleted:** ¶  
 ¶ Where ¶  
 ¶  $CTRR$  = "Generation / Demand split" corrected transport revenue recovery ¶  
 ¶  $p$  = Proportion of revenue to be recovered from demand ¶  
 ¶  $C$  = "Generation / Demand split" Correction constant (in km) ¶  
 ¶ The above equations deliver corrected (£/MW) transport tariffs (CTT). ¶  
 ¶  $(ZMkm_{G_i} + C) \times EC$  ¶  
 ¶  $(ZMkm_{D_i} - C) \times EC \times LS$  ¶  
 ¶ So that ¶  
 ¶  $\sum_{G_i=1}^{21} (CTT_{G_i} \times G_{G_i}) = CTRR$  ¶  
 ¶ and ¶  
 ¶  $\sum_{D_i=1}^{14} (CTT_{D_i} \times D_{D_i}) = CTRR$  ¶  
 ¶

**Formatted:** Justified

**Formatted:** Bullets and Numbering

**Formatted:** Bullets and Numbering

**Formatted:** Bullets and Numbering

**14.15.106** The process for calculating Local Substation Tariffs will be carried out for the first year of the price control and will subsequently be indexed by RPI for each subsequent year of the price control period.

**Formatted:** Bullets and Numbering

**14.15.107** The effective **Local Tariff** (£/kW) is calculated as the sum of the circuit and substation onshore and/or offshore components:

**Formatted:** Bullets and Numbering

$$ELT_{Gi} = CLT_{Gi} + SLT_{Gi}$$

Where

ELT<sub>Gi</sub> = Effective Local Tariff (£/kW)

SLT<sub>Gi</sub> = Substation Local Tariff (£/kW)

**14.15.108** Where tariffs do not change mid way through a charging year, final local tariffs will be the same as the effective tariffs:

**Formatted:** Bullets and Numbering

ELT<sub>Gi</sub> = LT<sub>Gi</sub>

Where

LT<sub>Gi</sub> = Final Local Tariff (£/kW)

**14.15.109** Where tariffs are changed part way through the year, the final tariffs will be calculated by scaling the effective tariffs to reflect that the tariffs are only applicable for part of the year and parties may have already incurred TNUoS liability.

**Formatted:** Bullets and Numbering

$$FT_{Gi} = \frac{12 \times \left( ET_{Gi} \times \sum_{Gi=1}^n G_{Gi} - FL_{Gi} \right)}{b \times \sum_{Gi=1}^n G_{Gi}} \quad \text{and} \quad FT_{Di} = \frac{12 \times \left( ET_{Di} \times \sum_{Di=1}^{14} D_{Di} - FL_{Di} \right)}{b \times \sum_{Di=1}^{14} D_{Di}}$$

Where:

b = number of months the revised tariff is applicable for

FLL = Forecast local liability incurred over the period that the original tariff is applicable for

**14.15.110** For the purposes of charge setting, the total local charge revenue is calculated by:

**Formatted:** Bullets and Numbering

$$LCRR_G = \sum_{j=Gi} LT_{Gi} * G_j$$

Where

LCRR<sub>G</sub> = Local Charge Revenue Recovery

G<sub>j</sub> = Forecast chargeable Generation or Transmission Entry Capacity in kW (as applicable) for each generator (based on confidential information received from Users)

**Offshore substation local tariff**

**14.15.111** All offshore chargeable generation is subject to an offshore substation tariff. The offshore substation tariff shall be the sum of transformer, switchgear and platform components.

**Formatted:** Bullets and Numbering

**14.15.112** Each tariff component, expressed in £/kW, shall be the ratio of the Offshore Transmission Owner revenue (£) and rating associated with the transformers, switchgear or platform (kW) at each offshore substation. The Offshore Transmission Owner revenue of each tariff component shall include that associated with asset spares. In the case of the platform component, the relevant rating shall be the lower of the transformer or switchgear ratings. As with the offshore circuit

**Formatted:** Bullets and Numbering

expansion factors, the Offshore Transmission Owner revenue associated with each tariff component shall be averaged over the remaining years of the NETSO price control.

**14.15.113** Offshore Transmission Owner revenue associated with interest during construction and project development overheads will be attributed to the relevant asset category with which it is associated. If these or any other costs included in the Offshore Transmission Owner revenue are not readily attributable to a given asset category, they will be pro-rated across the various asset categories based on their relative cost.

Formatted: Bullets and Numbering

**14.15.114** For 2010/11 a discount of £0.345590/kW shall be provided to the offshore substation tariff to reflect the average cost of civil engineering for onshore substations. This will be inflated by RPI each year and reviewed every price control period.

Formatted: Bullets and Numbering

**14.15.115** Offshore substation tariffs shall be inflated by RPI each year and reviewed every price control period.

Formatted: Bullets and Numbering

**14.15.116** The revenue from the offshore substation local tariff is calculated by:

$$SLTR = \sum_{\substack{\text{All offshore} \\ \text{substations}}} \left( SLT_k \times \sum_k Gen_k \right)$$

Formatted: Bullets and Numbering

Formatted: Indent: Left: 3.81 cm

Where:

SLT<sub>k</sub> = the offshore substation tariff for substation k  
 Gen<sub>k</sub> = the generation connected to offshore substation k

**The Residual Tariff**

**14.15.117** The total revenue to be recovered through TNUoS charges is determined each year with reference to the Transmission Licensees' Price Control formulas less the costs expected to be recovered through Pre-Vesting connection charges. Hence in any given year t, a target revenue figure for TNUoS charges (TRR<sub>t</sub>) is set after adjusting for any under or over recovery for and including, the small generators discount is as follows:

Formatted: Bullets and Numbering

$$TRR_t = R_t - PVC_t - SG_{t-1}$$

Where

TRR<sub>t</sub> = TNUoS Revenue Recovery target for year t  
 R<sub>t</sub> = Forecast Revenue allowed under The Company's RPI-X Price Control Formula for year t (this term includes a number of adjustments, including for over/under recovery from the previous year). For further information, refer to Special Condition D2 of The Company's Transmission Licence.  
 PVC<sub>t</sub> = Forecast Revenue from Pre-Vesting connection charges for year t  
 SG<sub>t-1</sub> = The proportion of the under/over recovery included within R<sub>t</sub> which relates to the operation of statement C13 of the The Company Transmission Licence. Should the operation of statement C13 result in an under recovery in year t – 1, the SG figure will be positive and vice versa for an over recovery.

**14.15.118** In normal circumstances, the revenue forecast to be recovered from the initial transport tariffs will not equate to the total revenue target. This is due to a number of factors. For example, the transport model assumes, for simplicity, smooth incremental transmission investments can be made. In reality, transmission investment can only be made in discrete 'lumps'. The transmission system has been planned and developed over a long period of time. Forecasts and assessments used

Deleted: corrected

Formatted: Bullets and Numbering

for planning purposes will not have been borne out precisely by events and therefore some distinction between an optimal system for one year and the actual system can be expected.

**14.15.119** As a result of the factors above, in order to ensure adequate revenue recovery, a constant non-locational **Residual Tariff** for generation and demand is calculated, which includes infrastructure substation asset costs. It is added to the initial transport tariffs for both Peak Security and Year Round backgrounds so that the correct generation / demand revenue split is maintained and the total revenue recovery is achieved.

$$RT_D = \frac{(p \times TRR) - ITRR_{DPS} - ITRR_{DYS}}{\sum_{Di=1}^{14} D_{Di}}$$

$$RT_G = \frac{[(1-p) \times TRR] - ITRR_{GPS} - ITRR_{GYRNS} - ITRR_{GYRS} - LCRR_G}{\sum_{Gi=1}^n G_{Gi}}$$

Where  
 RT = Residual Tariff (£/MW)  
 p = Proportion of revenue to be recovered from demand

**Formatted:** Bullets and Numbering

**Deleted:** corrected

**Deleted:**  $RT_D = \frac{(p \times TRR)}{\sum_{Di=1}^{14}}$

**Deleted:**  $RT_G = [(1-p) \times$

**Formatted:** Highlight

**Formatted:** Font: Arial

**Formatted:** Font: Arial

**Final £/kW Tariff**

**14.15.120** The effective Transmission Network Use of System tariff (TNUoS) can now be calculated as the sum of the initial transport wider tariffs for Peak Security and Year Round backgrounds, the non-locational residual tariff and the local tariff:

$$ET_{Gi} = \frac{ITT_{GiPS} + ITT_{GiYRNS} + ITT_{GiYRS} + RT_G + LT_{Gi}}{1000} \text{ and } ET_{Di} = \frac{ITT_{DiPS} + ITT_{DiYR} + RT_D}{1000}$$

Where:  
 ET = Effective TNUoS Tariff expressed in £/kW (ET<sub>Gi</sub> would only be applicable to a Power Station with a PS flag of 1 and ALF of 1; in all other circumstances ITT<sub>GiPS</sub>, ITT<sub>GiYRNS</sub> and ITT<sub>GiYRS</sub> will be applied using Power Station specific data)

For the purposes of the annual Statement of Use of System Charges ET<sub>Gi</sub> will be published as ITT<sub>GiPS</sub>, ITT<sub>GiYRNS</sub>, ITT<sub>GiYRS</sub>, RT<sub>G</sub> and LT<sub>Gi</sub>

**14.15.121** Where tariffs do not change mid way through a charging year, final demand and generation tariffs will be the same as the effective tariffs.

$$FT_{Gi} = ET_{Gi} \quad \text{and} \quad FT_{Di} = ET_{Di}$$

**14.15.122** Where tariffs are changed part way through the year, the final tariffs will be calculated by scaling the effective tariffs to reflect that the tariffs are only applicable for part of the year and parties may have already incurred TNUoS liability.

$$FT_{Gi} = \frac{12 \times \left( ET_{Gi} \times \sum_{Gi=1}^{20} G_{Gi} - FL_{Gi} \right)}{b \times \sum_{Gi=1}^{27} G_{Gi}} \quad \text{and} \quad FT_{Di} = \frac{12 \times \left( ET_{Di} \times \sum_{Di=1}^{14} D_{Di} - FL_{Di} \right)}{b \times \sum_{Di=1}^{14} D_{Di}}$$

**Formatted:** Bullets and Numbering

**Deleted:** corrected

**Deleted:**  $ET_{Gi} = \frac{ITT_{Gi}^{PS} +$

**Deleted:**

**Deleted:**  $ET_{Di} = \frac{ITT_{Di}^{PS} + ITT_{Di}^{YR}}{1000}$

**Formatted:** Font: Arial

**Formatted:** Font: Arial

**Formatted:** Indent: Left: 0.46 cm, Tabs: Not at 2 cm

**Formatted:** Highlight

**Formatted:** Highlight

**Formatted:** Bullets and Numbering

**Formatted:** Bullets and Numbering

**Deleted:**  $FT_{Gi} = \frac{12 \times (ET_{Gi}}$

**Deleted:**

Where:

b = number of months the revised tariff is applicable for

FL = Forecast liability incurred over the period that the original tariff is applicable for

Note: The  $ET_{G_i}$  element used in the formula above will be based on an individual Power Stations PS flag and ALF for Power Station  $G_{G_i}$ , aggregated to ensure overall correct revenue recovery.

**14.15.123** If the final demand TNUoS Tariff results in a negative number then this is collared to £0/kW with the resultant non-recovered revenue smeared over the remaining demand zones:

If  $FT_{D_i} < 0$ , then  $i = 1$  to  $z$

Therefore,

$$NRRT_D = \frac{\sum_{i=1}^z (FT_{D_i} \times D_{D_i})}{\sum_{i=z+1}^{14} D_{D_i}}$$

Therefore the revised Final Tariff for the demand zones with positive Final tariffs is given by:

For  $i = 1$  to  $z$ :  $RFT_{D_i} = 0$

For  $i = z+1$  to  $14$ :  $RFT_{D_i} = FT_{D_i} + NRRT_D$

Where

$NRRT_D$  = Non Recovered Revenue Tariff (£/kW)

$RFT_{D_i}$  = Revised Final Tariff (£/kW)

**14.15.124** The tariffs applicable for any particular year are detailed in The Company's **Statement of Use of System Charges**, which is available from the **Charging website**. Archived tariff information may also be obtained from the Charging website.

**14.15.125** The zonal maps referenced in The Company's **Statement of Use of System Charges** and available on the **Charging website** contain detailed information for the charging year in question of which Grid Supply Points fall into which TNUoS zones.

**14.15.126** New Grid Supply Points will be classified into zones on the following basis:

- For demand zones, according to the GSP Group to which the Grid Supply Point is allocated for energy market settlement purposes.
- For generation zones, with reference to the geographic proximity to existing zones and where close to a boundary between existing zones, with reference to the marginal costs arising from transport model studies. The GSP will then be allocated to the zone, which contains the most similar marginal costs.

**14.15.127** The Company has available, upon request, the DCLF ICRP transport model, tariff model template and data necessary to run the model, consisting of nodal values of generation and demand connection points to the NETS. The model and data will enable the basic nodal charges to be determined and will also allow sensitivity

**Formatted:** Bullets and Numbering

**Formatted:** Bullets and Numbering

**Formatted:** Bullets and Numbering

**Formatted:** Bullets and Numbering

**Formatted:** Indent: Left: 1.25 cm, Hanging: 0.75 cm, Bulleted + Level: 1 + Aligned at: 0 cm + Tab after: 0.63 cm + Indent at: 0.63 cm, Tabs: 2 cm, List tab + Not at 0.63 cm + 1.27 cm

**Formatted:** Indent: Left: 1.25 cm, Hanging: 0.75 cm, Bulleted + Level: 1 + Aligned at: 0 cm + Tab after: 0.63 cm + Indent at: 0.63 cm, Tabs: 2 cm, List tab + Not at 0.63 cm + 1.27 cm

**Formatted:** Bullets and Numbering

analysis concerning alternative developments of generation and demand to be undertaken. The model is available from the Charging Team and whilst it is free of charge, it is provided under licence to restrict its distribution and commercial use.

14.15.128 The Company will be pleased to run specific sensitivity studies for Users under a separate study contract in line with the fees set out in the **Statement of Use of System Charges**. Please contact the **Charging Team**.

**Formatted:** Bullets and Numbering

14.15.129 The factors which will affect the level of TNUoS charges from year to year include:

**Formatted:** Bullets and Numbering

- the forecast level of peak demand on the system
- the Price Control formula (including the effect of any under/over recovery from the previous year)
- the expansion constant
- the locational security factor
- the PS flag
- the ALF of a generator
- changes in the transmission network
- HVDC circuit impedance calculation
- changes in the pattern of generation capacity and demand

**Deleted:**

**Deleted:** ,

**Deleted:** ),

**Deleted:** ,

**Deleted:** ,

**Deleted:** and

**Formatted:** Bulleted + Level: 1 + Aligned at: 3.81 cm + Tab after: 4.51 cm + Indent at: 4.51 cm, Tabs: Not at 1.27 cm

**Deleted:** .

14.15.130 In accordance with Standard Licence Condition C13, generation directly connected to the NETS 132kV transmission network which would normally be subject to generation TNUoS charges but would not, on the basis of generating capacity, be liable for charges if it were connected to a licensed distribution network qualifies for a reduction in transmission charges by a designated sum, determined by the Authority. Any shortfall in recovery will result in a unit amount increase in demand charges to compensate for the deficit. Further information is provided in the Statement of the Use of System Charges.

**Formatted:** Bullets and Numbering

**Stability & Predictability of TNUoS tariffs**

14.15.131 A number of provisions are included within the methodology to promote the stability and predictability of TNUoS tariffs. These are described in 14.29.

**Formatted:** Bullets and Numbering

**Deleted:** 8

## 14.16 Derivation of the Transmission Network Use of System Energy Consumption Tariff and Short Term Capacity Tariffs

- 14.16.1 For the purposes of this section, Lead Parties of Balancing Mechanism (BM) Units that are liable for Transmission Network Use of System Demand Charges are termed Suppliers.
- 14.16.2 Following calculation of the Transmission Network Use of System £/kW Demand Tariff (as outlined in Chapter 2: Derivation of the TNUoS Tariff) for each GSP Group is calculated as follows:

$$\text{p/kWh Tariff} = \frac{(\text{NHHD}_F * \text{£/kW Tariff} - \text{FL}_G) * 100}{\text{NHHC}_G}$$

Where:

**£/kW Tariff** = The £/kW Effective Demand Tariff (£/kW), as calculated previously, for the GSP Group concerned.

**NHHD<sub>F</sub>** = The Company's forecast of Suppliers' non-half-hourly metered Triad Demand (kW) for the GSP Group concerned. The forecast is based on historical data.

**FL<sub>G</sub>** = Forecast Liability incurred for the GSP Group concerned.

**NHHC<sub>G</sub>** = The Company's forecast of GSP Group non-half-hourly metered total energy consumption (kWh) for the period 16:00 hrs to 19:00hrs inclusive (i.e. settlement periods 33 to 38) inclusive over the period the tariff is applicable for the GSP Group concerned.

### Short Term Transmission Entry Capacity (STTEC) Tariff

- 14.16.3 The Short Term Transmission Entry Capacity (STTEC) tariff for positive zones is derived from the Effective Tariff (ET<sub>Gi</sub>) annual TNUoS £/kW tariffs (14.15.109). If multiple set of tariffs are applicable within a single charging year, the Final Tariff used in the STTEC calculation will be prorated in an identical manner to that used when calculating a generators annual liability. The periods over which the tariff would be prorated would be identical to the periods used when calculating the wider tariff (i.e. over the whole financial year, not just the period that the STTEC is applicable for). STTECs will not be reconciled following a mid year charge change. The premium associated with the flexible product is associated with the analysis that 90% of the annual charge is linked to the system peak. The system peak is likely to occur in the period of November to February inclusive (120 days, irrespective of leap years). The calculation for positive generation zones is as follows:

Deleted: relevant

$$\frac{FT_{Gi} \times 0.9 \times \text{STTEC Period}}{120} = \text{STTEC tariff (£/kW/period)}$$

Where:

FT = Final annual TNUoS Tariff expressed in £/kW  
 Gi = Generation zone  
 STTEC Period = A period applied for in days as defined in the CUSC



14.16.4 For the avoidance of doubt, the charge calculated under 14.16.3 above will represent each single period application for STTEC. Requests for multiple STTEC periods will result in each STTEC period being calculated and invoiced separately.

14.16.5 The STTEC tariff for generators with negative final tariffs is set to zero to prevent Users receiving greater than 100% of the annual TNUoS payment that would have been received for that capacity under a firm TEC.

### Limited Duration Transmission Entry Capacity (LDTEC) Tariffs

14.16.6 The Limited Duration Transmission Entry Capacity (LDTEC) tariff for positive zones is derived from the equivalent zonal STTEC tariff for up to the initial 17 weeks of LDTEC in a given charging year (whether consecutive or not). For the remaining weeks of the year, the LDTEC tariff is set to collect the balance of the annual TNUoS liability over the maximum duration of LDTEC that can be granted in a single application. If multiple set of tariffs are applicable within a single charging year, the Final Tariff used in the LDTEC calculation will be prorated in an identical manner to that used when calculating a generators annual liability. The periods over which the tariff would be prorated would be identical to the periods used when calculating the wider tariff (ie over the whole financial year, not just the period that the STTEC is applicable for). LDTECs will not be reconciled following a mid year charge change:

Initial 17 weeks (high rate):

$$\text{LDTEC tariff (£/kW/week)} = \frac{FT_{G_i} \times 0.9 \times 7}{120}$$

Remaining weeks (low rate):

$$\text{LDTEC tariff (£/kW/week)} = \frac{FT_{G_i} \times 0.1075 \times 7}{316 - 120} \times (1 + P)$$

where  $FT$  is the final annual TNUoS tariff expressed in £/kW;

$G_i$  is the generation TNUoS zone; and

$P$  is the premium in % above the annual equivalent TNUoS charge as determined by The Company, which shall have the value 0.

14.16.7 The LDTEC tariff for generators with negative final tariffs is set to zero to prevent Users receiving greater than 100% of the annual TNUoS payment that would have been received for that capacity under a firm TEC.

14.16.8 The tariffs applicable for any particular year are detailed in The Company's **Statement of Use of System Charges** which is available from the **Charging website**. Historical tariffs are also available on the **Charging website**.

## 14.17 Demand Charges

### Parties Liabile for Demand Charges

14.17.1 The following parties shall be liable for demand charges:

- The Lead Party of a Supplier BM Unit;
- Power Stations with a Bilateral Connection Agreement;
- Parties with a Bilateral Embedded Generation Agreement

14.17.2 Classification of parties for charging purposes provides an illustration of how a party is classified in the context of Use of System charging and refers to the paragraphs most pertinent to each party.

### Basis of Demand Charges

14.17.3 Demand charges are based on a de-minimus £0/kW charge for Half Hourly and £0/kWh for Non Half Hourly metered demand.

14.17.4 Chargeable Demand Capacity is the value of Triad demand (kW). Chargeable Energy Capacity is the energy consumption (kWh). The definition of both these terms is set out below.

14.17.5 If there is a single set of demand tariffs within a charging year, the Chargeable Demand Capacity is multiplied by the relevant demand tariff, for the calculation of demand charges.

14.17.6 If there is a single set of energy tariffs within a charging year, the Chargeable Energy Capacity is multiplied by the relevant energy consumption tariff for the calculation of energy charges..

14.17.7 If multiple sets of demand tariffs are applicable within a single charging year, demand charges will be calculated by multiplying the Chargeable Demand Capacity by the relevant tariffs pro rated across the months that they are applicable for, as below,

$$Annual\ Liability_{Demand} = Chargeable\ Demand\ Capacity \times \left( \frac{(a \times Tariff\ 1) + (b \times Tariff\ 2)}{12} \right)$$

where:

Tariff 1 = Original tariff,

Tariff 2 = Revised tariff,

a = Number of months over which the original tariff is applicable,

b = Number of months over which the revised tariff is applicable.

**Formatted:** Indent: Left: 2.54 cm, Bulleted + Level: 1 + Aligned at: 0 cm + Tab after: 0.63 cm + Indent at: 0.63 cm, Tabs: 2.54 cm, List tab + Not at 0.63 cm + 1.27 cm

**Formatted:** Indent: Left: 2.54 cm, Bulleted + Level: 1 + Aligned at: 0 cm + Tab after: 0.63 cm + Indent at: 0.63 cm, Tabs: 2.54 cm, List tab + Not at 0.63 cm + 1.27 cm

**Formatted:** Indent: Left: 2.54 cm, Bulleted + Level: 1 + Aligned at: 0 cm + Tab after: 0.63 cm + Indent at: 0.63 cm, Tabs: 2.54 cm, List tab + Not at 0.63 cm + 1.27 cm

**Deleted:** 14.25

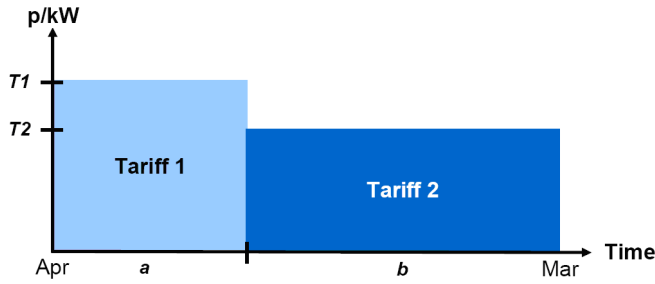

14.17.8 If multiple sets of energy tariffs are applicable within a single charging year, energy charges will be calculated by multiplying relevant Tariffs by the Chargeable Energy Capacity over the period that that the tariffs are applicable for and summing over the year.

$$Annual Liability_{Energy} = Tariff\ 1 \times \sum_{T1_s}^{T1_E} Chargeable\ Energy\ Capacity + Tariff\ 2 \times \sum_{T2_s}^{T2_E} Chargeable\ Energy\ Capacity$$

Where:

- T1<sub>s</sub> = Start date for the period for which the original tariff is applicable,
- T1<sub>E</sub> = End date for the period for which the original tariff is applicable,
- T2<sub>s</sub> = Start date for the period for which the revised tariff is applicable,
- T2<sub>E</sub> = End date for the period for which the revised tariff is applicable.

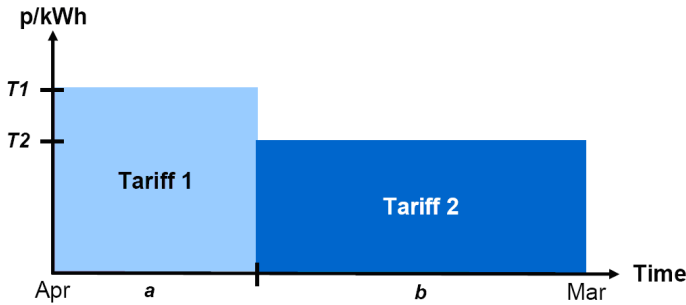

**Supplier BM Unit**

14.17.9 A Supplier BM Unit charges will be the sum of its energy and demand liabilities where::

- The Chargeable Demand Capacity will be the average of the Supplier BM Unit's half-hourly metered demand during the Triad (and the £/kW tariff), and
- The Chargeable Energy Capacity will be the Supplier BM Unit's non half-hourly metered energy consumption over the period 16:00 hrs to 19:00 hrs inclusive every day over the Financial Year (and the p/kWh tariff).

**Formatted:** Indent: Left: 2.5 cm, Bulleted + Level: 1 + Aligned at: 0 cm + Tab after: 0.63 cm + Indent at: 0.63 cm, Tabs: 3.14 cm, List tab + Not at 0.63 cm + 1.27 cm

**Formatted:** Indent: Left: 2.48 cm, Bulleted + Level: 1 + Aligned at: 0 cm + Tab after: 0.63 cm + Indent at: 0.63 cm, Tabs: 3.12 cm, List tab + Not at 0.63 cm + 1.27 cm

**Power Stations with a Bilateral Connection Agreement and Licensable Generation with a Bilateral Embedded Generation Agreement**

14.17.10 The Chargeable Demand Capacity for a Power Station with a Bilateral Connection Agreement or Licensable Generation with a Bilateral Embedded Generation Agreement will be based on the average of the net import over each Triad leg of the BM Units associated with the Power Station (in Appendix C of its Bilateral Connection Agreement or Bilateral Embedded Generation Agreement, including metered additional load) during the Triad.

**Exemptible Generation and Derogated Distribution Interconnectors with a Bilateral Embedded Generation Agreement**

14.17.11 The Chargeable Demand Capacity for Exemptible Generation and Derogated Distribution Interconnectors with a Bilateral Embedded Generation Agreement will be based on the average of the metered volume of each BM Unit specified in Appendix C of the Bilateral Embedded Generation Agreement during the Triad.

**Small Generators Tariffs**

14.17.12 In accordance with Standard Licence Condition C13, any under recovery from the MAR arising from the small generators discount will result in a unit amount of increase to all GB demand tariffs.

**The Triad**

14.17.13 The Triad is used as a short hand way to describe the three settlement periods of highest transmission system demand within a Financial Year, namely the half hour settlement period of system peak demand and the two half hour settlement periods of next highest demand, which are separated from the system peak demand and from each other by at least 10 Clear Days, between November and February of the Financial Year inclusive. Exports on directly connected Interconnectors and Interconnectors capable of exporting more than 100MW to the Total System shall be excluded when determining the system peak demand. An illustration is shown below.

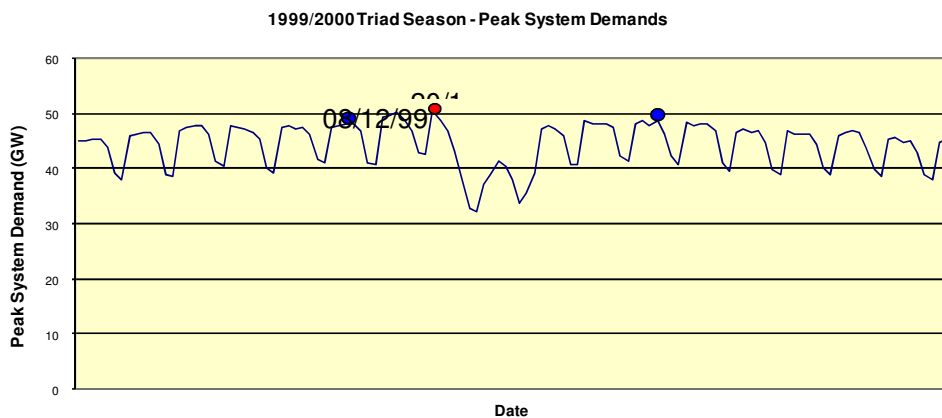

**Half-hourly metered demand charges**

14.17.14 For Supplier BMUs and BM Units associated with Exemptible Generation and Derogated Distribution Interconnectors with a Bilateral Embedded Generation

Agreement, if the average half-hourly metered volume over the Triad results in an import, the Chargeable Demand Capacity will be positive resulting in the BMU being charged. If the average half-hourly metered volume over the Triad results in an export, the Chargeable Demand Capacity will be negative resulting in the BMU being paid. For the avoidance of doubt, parties with Bilateral Embedded Generation Agreements that are liable for Generation charges will not be eligible for a negative demand credit.

**Netting off within a BM Unit**

14.17.15 The output of generators and Distribution Interconnectors registered as part of a Supplier BM Unit will have already been accounted for in the Supplier BM Unit demand figures upon which The Company Transmission Network Use of System Demand charges are based.

**Monthly Charges**

14.17.16 Throughout the year Users' monthly demand charges will be based on their forecasts of:

- half-hourly metered demand to be supplied during the Triad for each BM Unit, multiplied by the relevant zonal £/kW tariff; and
- non-half hourly metered energy to be supplied over the period 16:00 hrs to 19:00 hrs inclusive every day over the Financial Year for each BM Unit, multiplied by the relevant zonal p/kWh tariff

Users' annual TNUoS demand charges are based on these forecasts and are split evenly over the 12 months of the year. Users have the opportunity to vary their demand forecasts on a quarterly basis over the course of the year, with the demand forecast requested in February relating to the next Financial Year. Users will be notified of the timescales and process for each of the quarterly updates. The Company will revise the monthly Transmission Network Use of System demand charges by calculating the annual charge based on the new forecast, subtracting the amount paid to date, and splitting the remainder evenly over the remaining months. For the avoidance of doubt, only positive demand forecasts (i.e. representing an import from the system) will be accepted.

14.17.17 Users should submit reasonable demand forecasts in accordance with the CUSC. The Company shall use the following methodology to derive a forecast to be used in determining whether a User's forecast is reasonable, in accordance with the CUSC, and this will be used as a replacement forecast if the User's total forecast is deemed unreasonable. The Company will, at all times, use the latest available Settlement data.

For existing Users:

i) The User's Triad demand for the preceding Financial Year will be used where User settlement data is available and where The Company calculates its forecast before the Financial Year. Otherwise, the User's average weekday settlement period 35 half-hourly metered (HH) demand in the Financial Year to date is compared to the equivalent average demand for the corresponding days in the preceding year. The percentage difference is then applied to the User's HH demand at Triad in the preceding Financial Year to derive a forecast of the User's HH demand at Triad for this Financial Year.

ii) The User's non half-hourly metered (NHH) energy consumption over the period 16:00 hrs to 19:00 hrs every day in the Financial Year to date is compared to the equivalent energy consumption over the corresponding days in the preceding year. The percentage difference is then applied to the User's total NHH energy

**Formatted:** Indent: Left: 2.54 cm, Hanging: 0.75 cm, Bulleted + Level: 1 + Aligned at: 0 cm + Tab after: 0.63 cm + Indent at: 0.63 cm, Tabs: 3.29 cm, List tab + Not at 0.63 cm + 1.27 cm

**Formatted:** Indent: Left: 2.54 cm, Hanging: 0.75 cm, Bulleted + Level: 1 + Aligned at: 0 cm + Tab after: 0.63 cm + Indent at: 0.63 cm, Tabs: 3.29 cm, List tab + Not at 0.63 cm + 1.27 cm

**Formatted:** Indent: Left: 2.87 cm, Numbered + Level: 1 + Numbering Style: i, ii, iii, ... + Start at: 1 + Alignment: Left + Aligned at: 0 cm + Tab after: 1 cm + Indent at: 1 cm, Tabs: 2.62 cm, List tab + Not at 1 cm + 1.27 cm

**Formatted:** Indent: Left: 2.87 cm, Numbered + Level: 1 + Numbering Style: i, ii, iii, ... + Start at: 2 + Alignment: Tab + Aligned at: 0 cm + Tab after: 1 cm + Indent at: 1 cm, Tabs: 2.62 cm, List tab + Not at 1 cm + 1.27 cm

consumption in the preceding Financial Year to derive a forecast of the User's NHH energy consumption for this Financial Year.

For new Users who have completed a Use of System Supply Confirmation Notice in the current Financial Year:

iii) The User's average weekday settlement period 35 half-hourly metered (HH) demand over the last complete month for which The Company has settlement data is calculated. Total system average HH demand for weekday settlement period 35 for the corresponding month in the previous year is compared to total system HH demand at Triad in that year and a percentage difference is calculated. This percentage is then applied to the User's average HH demand for weekday settlement period 35 over the last month to derive a forecast of the User's HH demand at Triad for this Financial Year.

**Formatted:** Indent: Left: 2.87 cm, Numbered + Level: 1 + Numbering Style: i, ii, iii, ... + Start at: 3 + Alignment: Left + Aligned at: 0 cm + Tab after: 1 cm + Indent at: 1 cm, Tabs: 2.62 cm, List tab + Not at 1 cm + 1.27 cm

iv) The User's non half-hourly metered (NHH) energy consumption over the period 16:00 hrs to 19:00 hrs every day over the last complete month for which The Company has settlement data is noted. Total system NHH energy consumption over the corresponding month in the previous year is compared to total system NHH energy consumption over the remaining months of that Financial Year and a percentage difference is calculated. This percentage is then applied to the User's NHH energy consumption over the month described above, and all NHH energy consumption in previous months is added, in order to derive a forecast of the User's NHH metered energy consumption for this Financial Year.

**Formatted:** Indent: Left: 2.87 cm, Numbered + Level: 1 + Numbering Style: i, ii, iii, ... + Start at: 3 + Alignment: Left + Aligned at: 0 cm + Tab after: 1 cm + Indent at: 1 cm, Tabs: 2.62 cm, List tab + Not at 1 cm + 1.27 cm

14.17.18 ~~14.28~~ Determination of The Company's Forecast for Demand Charge Purposes illustrates how the demand forecast will be calculated by The Company.

**Deleted:** 27

## Reconciliation of Demand Charges

14.17.19 The reconciliation process is set out in the CUSC. The demand reconciliation process compares the monthly charges paid by Users against actual outturn charges. Due to the Settlements process, reconciliation of demand charges is carried out in two stages; initial reconciliation and final reconciliation.

### Initial Reconciliation of demand charges

14.17.20 The initial reconciliation process compares Users' demand forecasts and corresponding monthly charges paid over the year against actual outturn data (using latest Settlement data available at the time) and corresponding charges. Initial reconciliation is carried out in two parts; Initial Reconciliation Part 1 deals with the reconciliation of half-hourly metered demand charges and Initial Reconciliation Part 2 deals with the reconciliation of non-half-hourly metered demand charges.

### Initial Reconciliation Part 1– Half-hourly metered demand

14.17.21 The Company will identify the periods forming the Triad once it has received Central Volume Allocation data from the Settlement Administration Agent for all days up to and including the last day of February. Once The Company has notified Users of the periods forming the Triad they will not be changed even if disputes are subsequently resolved which would change the periods forming the Triad.

14.17.22 Initial outturn charges for half-hourly metered demand will be determined using the latest available data of actual average Triad demand (kW) multiplied by the zonal demand tariff(s) (£/kW) applicable to the months concerned for each zone for that Financial Year. These actual values are then reconciled against the monthly charges paid in respect of half-hourly demand.

### Initial Reconciliation Part 2 – Non-half-hourly metered demand

14.17.23 Actual payments for non-half-hourly metered demand will be determined using the latest available actual energy consumption data (kWh) for the period 16:00 hrs to 19:00 hrs inclusive (i.e. settlement periods 33 to 38) over the year multiplied by the energy consumption tariff(s) (p/kWh) applicable to the months concerned for each zone. These actual values are then reconciled against the monthly charges paid in respect of non-half-hourly energy consumption.

### Final Reconciliation of demand charges

14.17.24 The final reconciliation process compares Users' charges (as calculated during the initial reconciliation process using the latest available data) against final output demand charges (based on final settlement data).

14.17.25 Final actual charges will be determined using the final demand reconciliation data taken from the Final Reconciliation Settlement Run or the Final Reconciliation Volume Allocation Run.

### Reconciliation of manifest errors

14.17.26 In the event that a manifest error, or multiple errors in the calculation of TNUoS tariffs results in a material discrepancy in a Users TNUoS tariff, the reconciliation process for all Users qualifying under Section 14.17.28 will be in accordance with Sections 14.17.20 to 14.17.25. The reconciliation process shall be carried out using recalculated TNUoS tariffs. Where such reconciliation is not practicable, a post-year reconciliation will be undertaken in the form of a one-off payment.

14.17.27 A manifest error shall be defined as any of the following:

- a) an error in the transfer of relevant data between the Transmission Licensees or Distribution Network Operators;
- b) an error in the population of the Transport Model with relevant data;
- c) an error in the function of the Transport Model; or
- d) an error in the inputs or function of the Tariff Model.

14.17.28 A manifest error shall be considered material in the event that such an error or, the net effect of multiple errors, has an impact of the lesser of either:

- a) an error in a User's TNUoS tariff of at least +/-£0.50/kWh; or
- b) an error in a User's TNUoS tariff which results in an error in the annual TNUoS charge of a User in excess of +/-£250,000.

14.17.29 A manifest error shall only be reconciled if it has been identified within the charging year for which the error has an effect. Errors identified outside of this period will not be eligible for reconciliation retrospectively.

### Further Information

14.17.30 ~~14.25~~ Reconciliation of Demand Related Transmission Network Use of System Charges of this statement illustrates how the monthly charges are reconciled against the actual values for demand and consumption for half-hourly and non-half-hourly metered demand respectively.

Deleted: 24

14.17.31 **The Statement of Use of System Charges** contains the £/kW zonal demand tariffs, and the p/kWh energy consumption tariffs for the current Financial Year.

14.17.32 [14.27 Transmission Network Use of System Charging Flowcharts](#) of this statement contains flowcharts demonstrating the calculation of these charges for those parties liable.

Deleted: 26



## 14.18 Generation charges

### Parties Liable for Generation Charges

14.18.1 The following CUSC parties shall be liable for generation charges:

- i) Parties of Generators that have a Bilateral Connection Agreement with The Company.
- ii) Parties of Licensable Generation that have a Bilateral Embedded Generation Agreement with The Company.

14.18.2 14.26 Classification of parties for charging purposes provides an illustration of how a party is classified in the context of Use of System charging and refers to the relevant paragraphs most pertinent to each party.

### Structure of Generation Charges

- 14.18.3 Generation Tariffs are comprised of Wider and Local Tariffs. The Wider Tariff is comprised of (i) a Peak Security element, (ii) a Year Round Not-Shared element, (iii) Year Round Shared element and (iv) a residual element. The Peak Security element of the Wider Tariff is not applicable for intermittent generators as the PS flag is set to zero.
- 14.18.4 The Local Tariff contains a substation element and may also contain a circuit element. Specifically, all transmission connected generation will be liable to pay a local substation charge, with some of these also being liable to pay a local circuit charge. For the avoidance of doubt, embedded generation has a zero local tariff.
- 14.18.5 The intention of the charging rules is to charge the same physical entity only once.
- 14.18.6 The basis of the generation charge for Power Stations is the Chargeable Capacity and the short-term chargeable capacity (as defined below for positive and negative charging zones).
- 14.18.7 If there is a single set of Wider and Local generation tariffs within a charging year, the Chargeable Capacity is multiplied by the relevant generation tariff to calculate the annual liability of a generator.

$$\text{Local Annual Liability} = \text{Chargeable Capacity} \times \text{Local Tariff}$$

The Wider Tariff is broken down into four components as described in 14.18.3. The breakdown of the Wider Charge for Conventional and Intermittent Power Stations are given below:

Conventional -

$$\text{Wider Annual Liability} = \text{Chargeable Capacity} \times (\text{PSTariff} + \text{YRNSTariff} + (\text{YRSTariff} \times \text{ALF})) + \text{Residual Tariff}$$

Intermittent -

$$\text{Wider Annual Liability} = \text{Chargeable Capacity} \times (\text{YRNSTariff} + (\text{YRSTariff} \times \text{ALF})) + \text{Residual Tariff}$$

Where:

PS Tariff = Wider Peak Security Tariff

YRNS Tariff = Wider Year Round Not-Shared Tariff

**Formatted:** Indent: Left: 2.87 cm, Hanging: 1.27 cm, Numbered + Level: 1 + Numbering Style: i, ii, iii, ... + Start at: 1 + Alignment: Left + Aligned at: 0 cm + Tab after: 1.27 cm + Indent at: 0.63 cm, Tabs: 4.14 cm, List tab + Not at 1.27 cm

**Formatted:** Indent: Left: 2.87 cm, Hanging: 1.27 cm, Numbered + Level: 1 + Numbering Style: i, ii, iii, ... + Start at: 1 + Alignment: Left + Aligned at: 0 cm + Tab after: 1.27 cm + Indent at: 0.63 cm, Tabs: 4.14 cm, List tab + Not at 1.27 cm

**Deleted:** 25

**Deleted:** Charges

**Deleted:** Charges,

**Formatted:** Highlight

**Deleted:** latter of which

**Formatted:** Highlight

**Formatted:** Highlight

**Formatted:** Highlight

**Formatted:** Highlight

**Formatted:** Highlight

**Formatted:** Highlight

**Formatted:** Highlight

**Formatted:** Highlight

**Formatted:** Highlight

**Formatted:** Highlight

**Formatted:** Highlight

**Formatted:** Highlight

**Formatted:** Highlight

**YRS Tariff = Wider Year Round Shared Tariff**

Formatted: Highlight  
Formatted: Indent: Left: 2.87 cm

14.18.8 If multiple sets of Wider and Local generation tariffs are applicable within a single charging year, the Chargeable Capacity is multiplied by the relevant tariffs pro rated over the entire charging year, across the months that they are applicable for.

$$\text{Annual Liability} = \left( \frac{a \times \text{Liability 1} + b \times \text{Liability 2}}{12} \right)$$

where:

Liability 1 = Original annual liability,

Liability 2 = Revised annual liability,

a = Number of months over which the original Liability is applicable,

b = Number of months over which the revised Liability is applicable.

Deleted: Tariff  
Deleted: tariff  
Deleted: Tariff  
Deleted: tariff  
Deleted: tariff  
Deleted: tariff

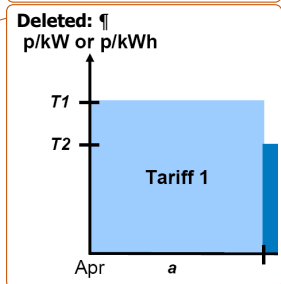
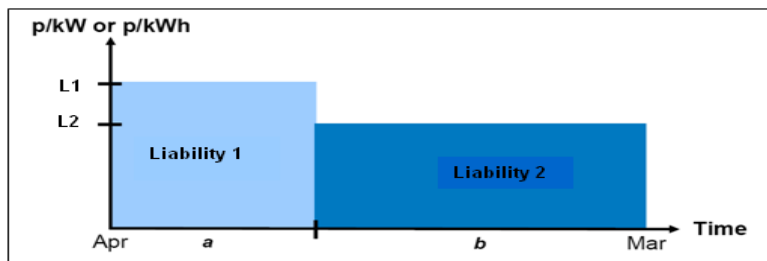

14.18.9 For the avoidance of doubt if there are multiple sets of Wider and Local generation tariffs applicable within a single charging year and a tariff changes from being positive to negative or vice versa, the Chargeable Capacity for the entire charging year will be determined based on the net position of the pro rated tariffs for each affected generator.

**Basis of Wider Generation Charges**

**Generation with positive wider tariffs**

14.18.10 The Chargeable Capacity for Power Stations with positive wider generation tariffs is the highest Transmission Entry Capacity (TEC) applicable to that Power Station for that Financial Year. A Power Station should not exceed its TEC as to do so would be in breach of the CUSC, except where it is entitled to do so under the specific circumstances laid out in the CUSC (e.g. where a User has been granted Short Term Transmission Entry Capacity, STTEC). For the avoidance of doubt, TNUoS Charges will be determined on the TEC held by a User as specified within a relevant bilateral agreement regardless of whether or not it enters into a temporary TEC Exchange (as defined in the CUSC).

14.18.11 The short-term chargeable capacity for Power Stations situated with positive generation tariffs is any approved STTEC or LDTEC applicable to that Power Station during a valid STTEC Period or LDTEC Period, as appropriate.

14.18.12 For Power Stations, the short term chargeable capacity for LDTEC with positive generation tariffs referred to in Paragraph 14.18.11, will be the capacity purchased

Deleted: 14.18.1114.18.1011

either on a profiled firm<sup>2</sup> or indicative<sup>3</sup> basis and shall be assessed according to the capacity purchased on a weekly basis. The short-term chargeable capacity for LDTEC in any week may comprise of a number of increments, which shall be determined by considering LDTEC purchased previously in the Financial Year (whether or not in the same LDTEC Period). For example, if in a given week the LDTEC is 200MW but in a previous week the LDTEC had been 150MW, the short-term chargeable capacity in the latter week would comprise of two increments: one of 150MW and a second of 50MW. Further examples are provided in 14.16.6.

### Generation with negative wider tariffs

14.18.13 The Chargeable Capacity for Power Stations with negative wider generation tariffs is the average of the capped metered volumes during the three settlement periods described in 14.18.14 below, for the Power Station (i.e. the sum of the metered volume of each BM Unit associated with Power Station in Appendix C of its Bilateral Agreement). A Power Station should not exceed its TEC as to do so would be in breach of the CUSC, except where it is entitled to do so under the specific circumstances laid out in the CUSC (e.g. where a User has been granted Short Term Transmission Entry Capacity). If TEC is exceeded, the metered volumes would each be capped by the TEC for the Power Station applicable for that Financial Year. For the avoidance of doubt, TNUoS Charges will be determined on the TEC held by a User as specified within a relevant bilateral agreement regardless of whether or not it enters into a temporary TEC Exchange (as defined in the CUSC).

Deleted: 14.18.14 14.18.13 14

14.18.14 The three settlement periods are those of the highest metered volumes for the Power Station and the two half hour settlement periods of the next highest metered volumes which are separated from the highest metered volumes and each other by at least 10 Clear Days, between November and February of the relevant Financial Year inclusive. These settlement periods do not have to coincide with the Triad.

#### Example

If the highest TEC for a Power Station were **250MW** and the highest metered volumes and resulting capped metered volumes were as follows:

Date	19/11/08	13/12/08	06/02/09
Highest Metered Volume in month (MW)	<b>245.5</b>	<b>250.3</b>	<b>251.4</b>
Capped Metered Volume (MW)	<b>245.5</b>	<b>250.0</b>	<b>250.0</b>

Then, the chargeable Capacity for the Power Station would be:

$$\left( \frac{245.5 + 250 + 250}{3} \right) = \mathbf{248.5 \text{ MW}}$$

Note that in the example above, the Generator has exceeded its TEC on 13 December 2007 and 6 February 2008 and would therefore be in breach of the CUSC unless the

<sup>2</sup> where an LDTEC Block Offer has been accepted (Profiled Block LDTEC) and a firm profile of capacity has been purchased.

<sup>3</sup> where an LDTEC Indicative Block Offer has been accepted (Indicative Profiled Block LDTEC) and a right to future additional capacity up to a requested level has been purchased, the availability of which will be notified on a weekly basis in accordance with the CUSC.

generator had an approved STTEC or LDTEC value. (The STTEC and LDTEC charge for negative zones is currently set at zero).

14.18.15 The short-term chargeable capacity for Power Stations with negative generation tariffs is any approved STTEC or LDTEC applicable to that Power Station during a valid STTEC Period or LDTEC Period, as applicable.

14.18.16 For Power Stations with negative generation tariffs, the short-term chargeable capacity for LDTEC referred to in Paragraph 14.18.15 will be the capacity purchased either on a profiled firm or indicative basis and shall be assessed according to the capacity purchased on a weekly basis. The short-term chargeable capacity for LDTEC in any week may comprise of a number of increments, which shall be determined by considering LDTEC purchased previously in the Financial Year (whether or not in the same LDTEC Period). For example, if in a given week the LDTEC is 200MW but in a previous week the LDTEC had been 150MW, the short-term chargeable capacity in the latter week would comprise of two increments: one of 150MW and a second at 50MW.

Deleted: 14

14.18.17 As noted above, a negative LDTEC tariff in negative generation charging zones is set to zero. Accordingly no payments will be made for use of LDTEC (in any of its forms) in these zones.

### Basis of Local Generation Charges

14.18.18 The Chargeable Capacity for Power Stations will be the same as that used for wider generation charges, except that each component of the local tariff shall be considered separately as to whether it is a positive or negative tariff component. This means that where a local circuit tariff is negative, the final charging liability for this element will be based on actual metered output as described in Paragraph 14.18.12.

### Small Generators Charges

14.18.19 Eligible small generators' tariffs are subject to a discount of a designated sum defined by Licence Condition C13 as 25% of the combined residual charge for generation and demand. The calculation for small generators charges is not part of the methodology however, for information the designated sum is included in **The Statement of Use of System Charges**.

### Monthly Charges

14.18.20 Initial Transmission Network Use of System Generation Charges for each Financial Year will be based on the Power Station Transmission Entry Capacity (TEC) for each User as set out in their Bilateral Agreement. The charge is calculated as above. This annual TNUoS generation charge is split evenly over the months remaining in the year. For positive final generation tariffs, if TEC increases during the charging year, the party will be liable for the additional charge incurred for the **full** year, which will be recovered uniformly across the remaining chargeable months in the relevant charging year (subject to Paragraph 14.18.21 below). An increase in monthly charges reflecting an increase in TEC during the charging year will result in interest being charged on the differential sum of the increased and previous TEC charge. The months liable for interest will be those preceding the TEC increase from April in year t. For negative final generation tariff, any increase in TEC during the year will lead to a recalculation of the monthly charges for the remaining chargeable months of the relevant charging year. However, as TEC decreases do not become effective until the start of the financial year following approval, no recalculation is necessary in these cases. As a result, if TEC increases, monthly payments to the generator will increase accordingly.

Deleted: .20

14.18.21 The provisions described above for increases in TEC during the charging year shall not apply where the LDTEC (in any of its forms) has been approved for use before the TEC is available, which will typically mean the LDTEC has been approved after the TEC increase has been approved. In such instances, the party shall commence payments for TEC during the LDTEC Period for LDTEC purchased up to the future level of TEC and LDTEC Charges will only apply to LDTEC that is incremental to the TEC increase. For the avoidance of doubt, where TEC has been approved after LDTEC in a given year, these provisions shall not apply and the LDTEC shall be considered additional to the TEC and charged accordingly.

### Ad hoc Charges

14.18.22 For each STTEC period successfully applied for, a charge will be calculated by multiplying the STTEC by the tariff calculated in accordance with Paragraph 14.16.3. The Company will invoice Users for the STTEC charge once the application for STTEC is approved.

Deleted: .

14.18.23 For Power Stations utilising LDTEC (in any of its forms) the LDTEC Charge for each LDTEC Period is the sum of the charging liabilities associated with each incremental level of short term chargeable capacity provided by LDTEC within the LDTEC Period (assessed on a weekly basis). The charging liability for a given incremental level of short term chargeable capacity is the sum of:

- i) the product of the higher tariff rate (calculated in accordance with Paragraph 14.16.6) and capacity purchased at this increment for the first 17 weeks in a Financial Year (whether consecutive or not); and
- ii) the product of the lower tariff rate (calculated in accordance with Paragraph 14.16.6) and capacity purchased at this increment in any additional weeks within the same Financial Year (whether consecutive or not).

14.18.24 For each LDTEC Period successfully applied for, the LDTEC Charge will be split evenly over the relevant LDTEC Period and charged on a monthly basis. LDTEC charges will apply to both LDTEC (in any of its forms) and Temporary Received TEC held by a User. For the avoidance of doubt, the charging methodology will not differentiate between access rights provided to a generator by LDTEC or through Temporary Received TEC obtained through a Temporary TEC Exchange (as defined in the CUSC).

### **Example**

The diagrams below show two cases where LDTEC has been purchased: in Case A, two LDTEC Periods have been purchased; and in Case B one LDTEC Period has been purchased. The total capacity purchased in both cases is the same. The top diagrams illustrate the capacity purchased, while lower diagrams illustrate the incremental levels of short term chargeable capacities of LDTEC and the tariff rate that would apply to that capacity.

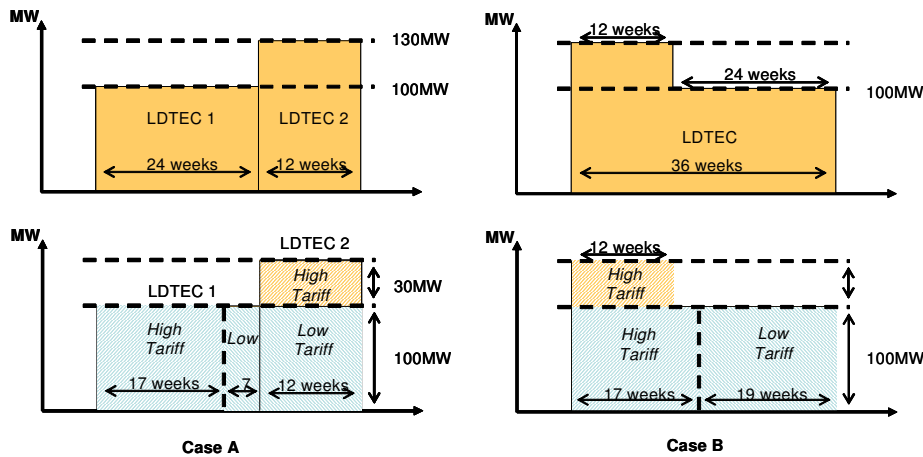

In both cases, the total amount charged for the LDTEC would be the same:

- Capacity charges at the higher tariff rate:
  - 17 weeks at the 100MW increment
  - 12 weeks at the 30MW increment
- Capacity charges at the lower tariff rate:
  - 19 weeks at the 100MW increment

**Formatted:** Indent: Left: 0 cm, Hanging: 0.44 cm, Bulleted + Level: 1 + Aligned at: 0 cm + Tab after: 0.63 cm + Indent at: 0.63 cm, Tabs: 0.44 cm, List tab + Not at 0.63 cm + 1.27 cm

**Formatted:** Indent: Left: 0 cm, Hanging: 0.47 cm, Bulleted + Level: 1 + Aligned at: 0 cm + Tab after: 0.63 cm + Indent at: 0.63 cm, Tabs: 0.47 cm, List tab + Not at 0.63 cm + 1.27 cm

### Embedded Transmission Use of System Charges “ETUoS”

- 14.18.25 The ETUoS charges are a component of Use of System charges levied on offshore generators whose offshore transmission connection is embedded in an onshore distribution network. The charge relates to the provision and use of the onshore distribution network.
- 14.18.26 The main purpose of ETUoS charges is to pass through the charges that are levied by the DNO on the NETSO to the offshore generator(s). This charge reflects the charges levied by the DNO for the costs of any works on and use of the DNO network in accordance with the DNO’s charging statements and will include, but is not limited to, upfront charges and capital contributions in respect of any works as well as the ongoing and annual Use of System charges for generation connected to the distribution network.
- 14.18.27 In the case of some relevant transitional offshore generation projects, ETUoS will also be used to pass through historic DNO capital contributions forming part of the Offshore Transmission Owner tender revenue stream.
- 14.18.28 The specific nature of the ETUoS charge and the payment profile for these will depend upon the charging arrangements of the relevant DNO and reference should be made to the relevant DNO’s charging statement. In terms of applicable transitional offshore generation projects the ETUoS payment profile will be consistent with the recovery of the Offshore Transmission Owner revenue stream.
- 14.18.29 Where a DNO’s charge relates to more than one offshore generator, the related ETUoS charge will represent a straight pass through of the distribution charge specific to each relevant offshore generator. Where specific information is not available, charges will be pro-rated based on the TEC of the relevant offshore generators connected to that offshore network.
- 14.18.30 Invoices for ETUoS charges shall be levied by the NETSO on the offshore generator as soon as reasonably practicable after invoices have been received by the NETSO for payment such that the NETSO can meet its payment obligations to the DNO. The

initial payments and payment dates will be outlined in a User's Construction Agreement and/or Bilateral Agreement.

14.18.31 As the ETUoS charges reflect the DNO charges to the NETSO, such charges will be subject to variation when varied by the DNO. Where the User disputes regarding the ETUoS charge please note that this will result in a dispute between the NETSO and DNO under the DCUSA.

### Reconciliation of Generation Charges

14.18.32 The reconciliation process is set out in the CUSC and in line with the principles set out above.

14.18.33 In the event of a manifest error in the calculation of TNUoS charges which results in a material discrepancy in a User's TNUoS charge as defined in Sections 14.17.27 to 14.17.29, the generation charges of Users qualifying under Section 14.17.28 will be reconciled in line with [14.18.20](#) and [14.18.25](#) using the recalculated tariffs.

Deleted: 14.18.2014.18.1920

Deleted: 14.18.2514.18.2425

### Further Information

14.18.34 **The Statement of Use of System Charges** contains the £/kW generation zonal tariffs for the current Financial Year.

## 14.19 Data Requirements

### Data Required for Charge Setting

- 14.19.1 Users who are Generators or Interconnector Asset Owners provide to The Company a forecast for the following Financial Year of the highest Transmission Entry Capacity (TEC) applicable to each Power Station or Interconnector for that Financial Year. For Financial Year 2008/9 Scottish Generators or Interconnector Asset Owners provide to The Company a forecast of the equivalent highest 'export' capacity figure. This data is required by The Company as the basis for setting TNUoS tariffs. The Company may request these forecasts in the November prior to the Financial Year to which they relate, in accordance with the CUSC. Additionally users who are Generators provide to The Company details of their generation plant type.
- 14.19.2 Users who are owners or operators of a User System (e.g. Distribution companies) provide a forecast for the following Financial Year of the Natural Demand attributable to each Grid Supply Point equal to the forecasts of Natural Demand under both Annual Average Cold Spell (ACS) Conditions and a forecast of the average metered Demand attributable to such Grid Supply Point for the National Grid Triad. This data is published in table 2.4 of the Seven Year Statement and is compiled from week 24 data submitted in accordance with the Grid Code.
- 14.19.3 For the following Financial Year, The Company shall use these forecasts as the basis of Transmission Network Use of System charges for such Financial Year. A description of how this data is incorporated is included in 14.15 Derivation of the Transmission Network Use of System Tariff.
- 14.19.4 If no data is received from the User, then The Company will use the best information available for the purposes of calculation of the TNUoS tariffs. This will normally be the forecasts provided for the previous Financial Year.

### Data Required for Calculating Users' Charges

- 14.19.5 In order for The Company to calculate Users' TNUoS charges, Users who are Suppliers shall provide to The Company forecasts of half-hourly and non-half-hourly demand in accordance with paragraph 14.17.14 and 14.17.15 and in accordance with the CUSC.



## 14.20 Applications

14.20.1 Application fees are payable in respect of applications for new Use of System agreements; modifications to existing agreements; and applications for short-term access products or services. These are based on the reasonable costs that transmission licensees incur in processing these applications.

### Applications for short-term access

14.20.2 Application fees for short-term access products or services are fixed and detailed in the **Statement of Use of System Charges**. These are non-refundable except for the following limited instances:

- Where a User (or Users) withdraw their application in accordance with any interactivity provisions that may be contained within the CUSC; or
- Where the application fee covers ongoing assessment work that is contingent on the acceptance of the offer.

14.20.3 In either case, the refunded amount will be proportional to the remaining assessment time available.

14.20.4 To ensure that application fees for short-term access are cost reflective, fees may be comprised of a number of components. For instance, the LDTEC Request Fee is comprised of a number of components and the total fee payable is the sum of those components that apply to the type(s) of LDTEC Offer(s) requested. For example:

- The LDTEC Request Fee for an LDTEC Block Offer is the basic request fee.
- The LDTEC Request Fee for an LDTEC Indicative Block Offer is the sum of the basic request fee and the additional rolling assessment fee.
- The LDTEC Request Fee payable for a combined LDTEC Block Offer and LDTEC Indicative Block Offer is the sum of the basic request fee, the additional rolling assessment fee, and the additional combined application fee.

**Formatted:** Indent: Left: 2.87 cm, Hanging: 0.75 cm, Bulleted + Level: 1 + Aligned at: 0 cm + Tab after: 0.63 cm + Indent at: 0.63 cm, Tabs: 3.62 cm, List tab + Not at 0.63 cm + 1.27 cm

**Formatted:** Indent: Left: 2.87 cm, Hanging: 0.75 cm, Bulleted + Level: 1 + Aligned at: 0 cm + Tab after: 0.63 cm + Indent at: 0.63 cm, Tabs: 3.62 cm, List tab + Not at 0.63 cm + 1.27 cm

**Formatted:** Indent: Left: 2.87 cm, Hanging: 0.75 cm, Bulleted + Level: 1 + Aligned at: 0 cm + Tab after: 0.63 cm + Indent at: 0.63 cm, Tabs: 3.62 cm, List tab + Not at 0.63 cm + 1.27 cm

### Applications for new or modified existing Use of System Agreements

14.20.5 Users can opt to pay a fixed price application fee in respect of their application or pay the actual costs incurred. The fixed price fees for applications are detailed in the **Statement of Use of System Charges**.

14.20.6 If a User chooses not to pay the fixed fee, the application fee will be based on an advance of transmission licensees' Engineering and out-of pocket expenses and will vary according to the size of the scheme and the amount of work involved. Once the associated offer has been signed or lapsed, a reconciliation will be undertaken. Where actual expenses exceed the advance, The Company will issue an invoice for the excess. Conversely, where The Company does not use the whole of the advance, the balance will be returned to the User.

14.20.7 The Company will refund the first application fee paid (the fixed fee or the amount post-reconciliation) and consent payments made under the Construction Agreement for new or modified existing agreements. The refund shall be made either on commissioning or against the charges payable in the first three years of the new or modified agreement. The refund will be net of external costs.

14.20.8 The Company will not refund application fees for applications to modify a new agreement or modified existing agreement at the User's request before any charges become payable. For example, The Company will not refund an application fee to delay the provision of a new connection if this is made prior to charges becoming payable.

## 14.21 Transport Model Example

For the purposes of the DCLF Transport algorithm, it has been assumed that the value of circuit impedance is equal to the value of circuit reactance.

Consider the following 3-node network, where generation at node A is intermittent and generation at node B is conventional:

Deleted: ¶

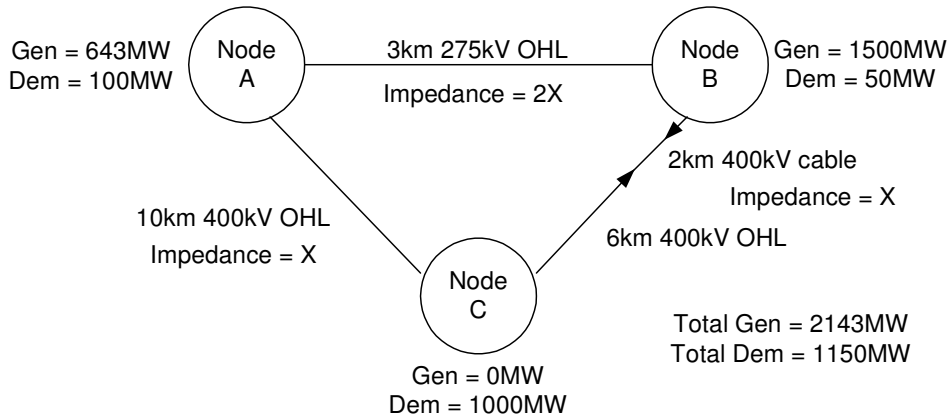

→ Denotes cable

For both Peak Security and Year Round generation backgrounds, the nodal generation is scaled according to the relevant Scaling Factors as set out in the Security Standard, such that total system generation equals total system demand.

Deleted: The first step is to match total demand

Deleted: total

Deleted: by scaling uniformly

Deleted: down

Deleted:

### Peak Security background:

A fixed scaling factor of 0% is applied to intermittent generation at node A and a variable scaling factor is applied to the conventional generation at node B so that the total generation is equal to the total demand.

Node A Generation =  $0 * 643\text{MW} = 0\text{MW}$

Deleted:  $1150/1495 * 650\text{MW} = 500\text{MW}$ ¶

Node B Generation =  $1150/1500 * 1500\text{MW} = 1150\text{MW}$

Deleted:  $1495 * 845\text{MW} = 650\text{MW}$ ¶

This gives the following balanced system, where the actual generation after the application of scaling factors is shown:

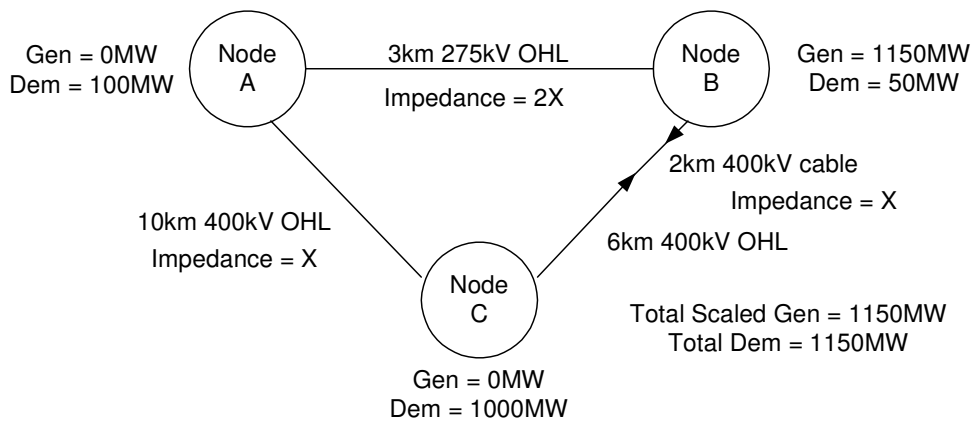

**Deleted:** ¶  
¶  
¶  
¶

**Formatted:** Font: Times New Roman, 12 pt

Assuming Node A is the reference node<sup>†</sup>, each 400kV circuit has impedance X, the 275kV circuit has impedance 2X, the 400kV cable circuit expansion factor is 10 and the 275kV overhead line circuit expansion factor is 2, the DCLF transport algorithm calculates the base case power flows for Peak Security background as follows:

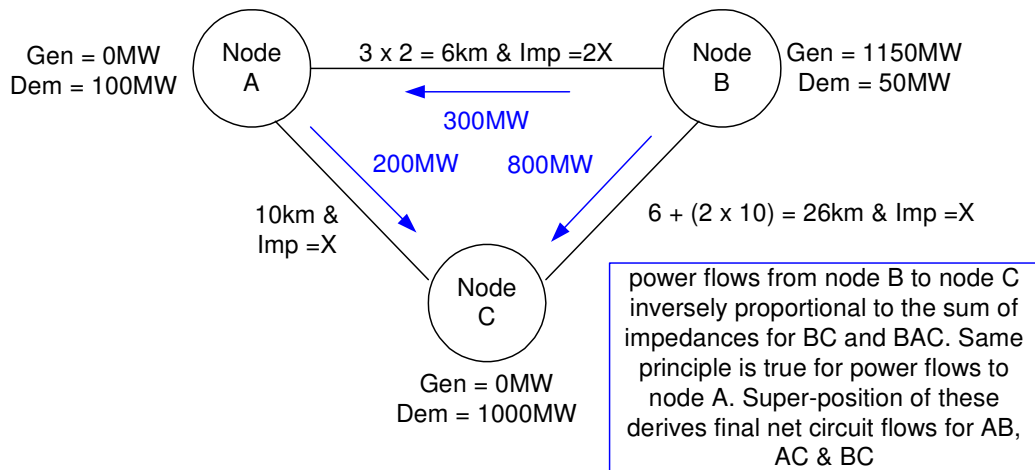

Node B exports, whilst Nodes A and C import. Hence the DCLF algorithm derives flows to deliver export power from Node B to meet import needs at Nodes A and C.

Step 1: Net export from Node B to Node A is 100MW; both routes BA and BC-CA have impedance 2X; hence 50MW would flow down both routes.

<sup>†</sup> For simplicity, fixed reference node has been used instead of a distributed reference node.

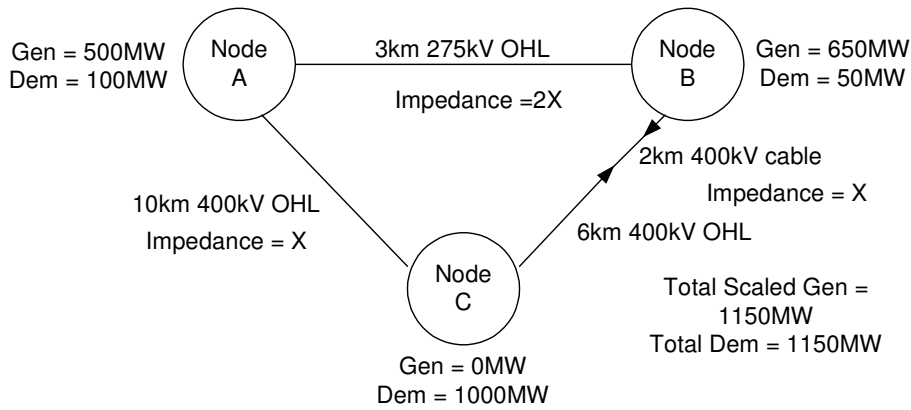

Step 2: Net export from Node B to Node C is 1000MW; route BC has impedance X and route BA-AC has impedance 3X; hence 750MW would flow down BC and 250MW along BA-AC

Step 3: Using super-position to add the flows derived in Steps 1 and 2 derives the following:

Flow AC	=	-50MW + 250MW	=	200MW
Flow AB	=	-50MW - 250MW	=	-300MW
Flow BC	=	50MW + 750MW	=	800MW

**Year Round background:**

A fixed scaling factor of 70% is applied to intermittent generation at node A and a variable scaling factor is applied to the conventional generation at node B so that the total generation is equal to the total demand.

Node A Generation = 70% \* 643MW = 450MW

Node B Generation = (1150-450)/1500 \* 1500MW = 700MW

This gives the following balanced system, where the actual generation after the application of scaling factors is shown:

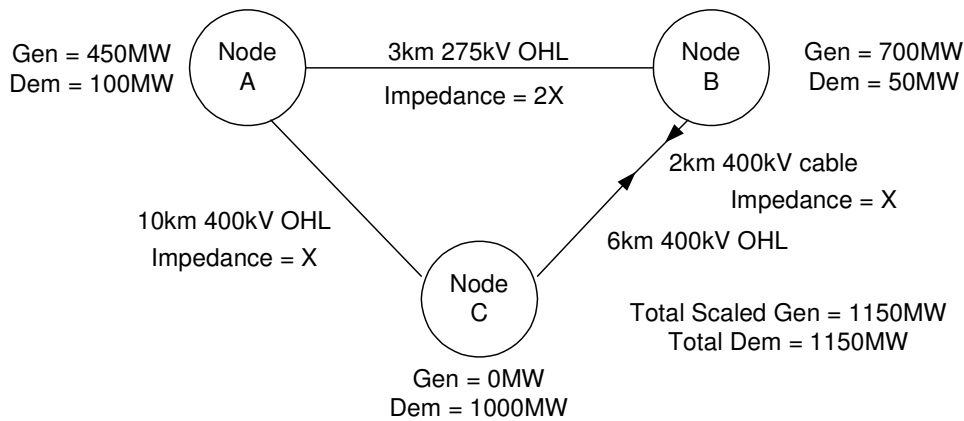

Assuming the same circuit impedances and expansion factors as used above in the Peak Security background, the DCLF transport algorithm calculates the base case power flows for Year Round background as follows:

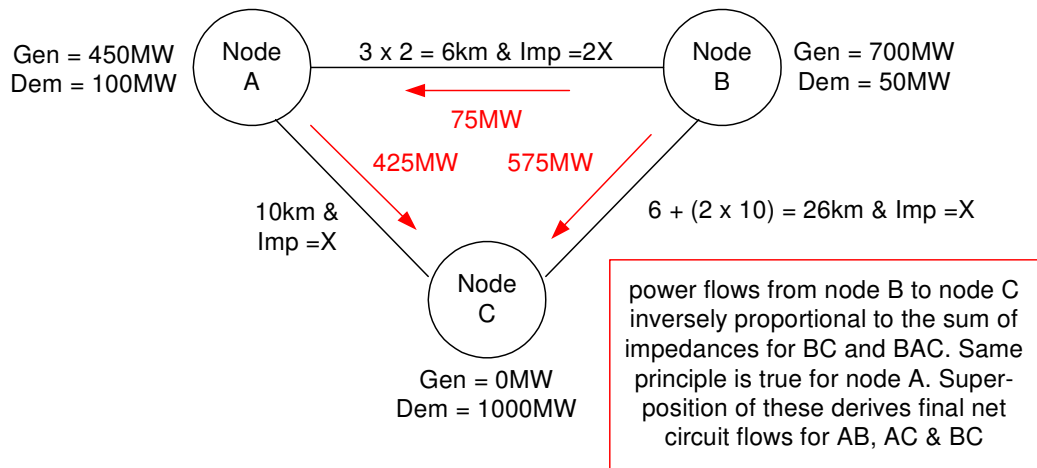

Nodes A and B export, whilst Node C imports. Hence the DCLF algorithm derives flows to deliver export power from Nodes A and B to meet import needs at Node C.

Step 1: Net export from Node A is 350MW; route AC has impedance X and route AB-BC has impedance 3X; hence 262.5MW would flow down AC and 87.5MW along AB-BC.

Step 2: Net export from Node B is 650MW; route BC has impedance X and route BA-AC has impedance 3X; hence 487.5MW would flow down BC and 162.5MW along BA-AC.

Step 3: Using super-position to add the flows derived in Steps 1 and 2 derives the following;

$$\begin{aligned} \text{Flow AC} &= \underline{262.5\text{MW} + 162.5\text{MW}} = \underline{425\text{MW}} \\ \text{Flow AB} &= \underline{87.5\text{MW} - 162.5\text{MW}} = \underline{-75\text{MW}} \\ \text{Flow BC} &= \underline{87.5\text{MW} + 487.5\text{MW}} = \underline{575\text{MW}} \end{aligned}$$

Then, based on the background giving rise to highest flow, each circuit is tagged as either Peak Security or Year Round.

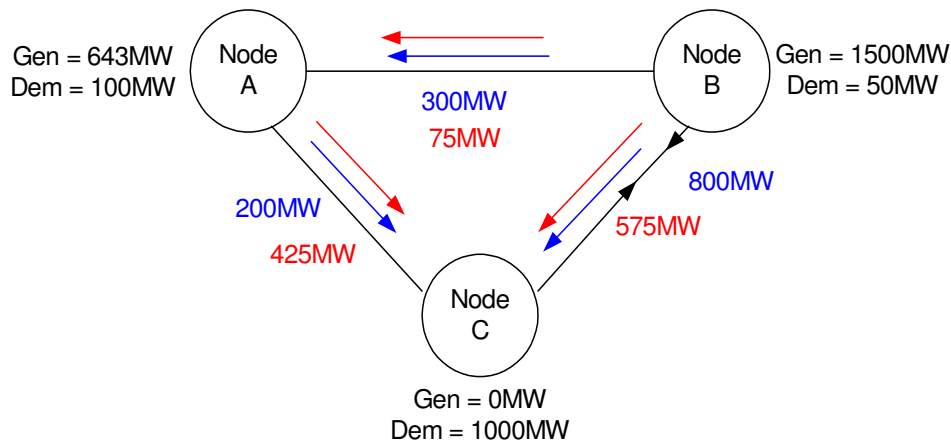

Therefore, circuits AB and BC are tagged as Peak Security and AC is tagged as Year Round.

Formatted: Font: Arial

Formatted: Body Text 2, Justified

Deleted: 400MW

Deleted: 300MW

Deleted: 100MW

Deleted: 600MW

Deleted: 450MW

Deleted: 150MW

Deleted: 300MW + 150MW . = . 450MW¶

Deleted: 100MW - 150MW . = . -50MW¶

Deleted: 100MW + 450MW . = . 550MW¶

Total Peak Security cost = (300 X 6) + (800 X 26) = 22,600 MWkm  
(base case)

Total Year Round cost = 425 X 10 = 4,250 MWkm  
(base case)

We then 'inject' 1MW of generation at each node with a corresponding 1MW offtake (demand) at the reference node and recalculate the total Peak Security MWkm cost and Year Round MWkm cost (noting that each circuit is only in one background). The difference from the base case for Peak Security and Year Round costs is the marginal km or shadow cost for Peak Security and Year Round networks respectively. The size and direction of the incremental MW is shown below along with the resultant when superimposed on the relevant base case flow (i.e. higher of the Peak Security and Year Round) depicted in brackets:.

- Deleted:**  $450 \times 10) + (50 \times$
- Formatted:** Font: 11 pt
- Formatted:** Font: 11 pt
- Deleted:**  $550 \times$
- Formatted:** Font: 11 pt
- Formatted:** Font: 11 pt
- Deleted:**  $19,100$
- Formatted:** Font: 11 pt
- Formatted:** Font: 11 pt
- Deleted:** in cost
- Deleted:** . This is demonstrated as follows:¶

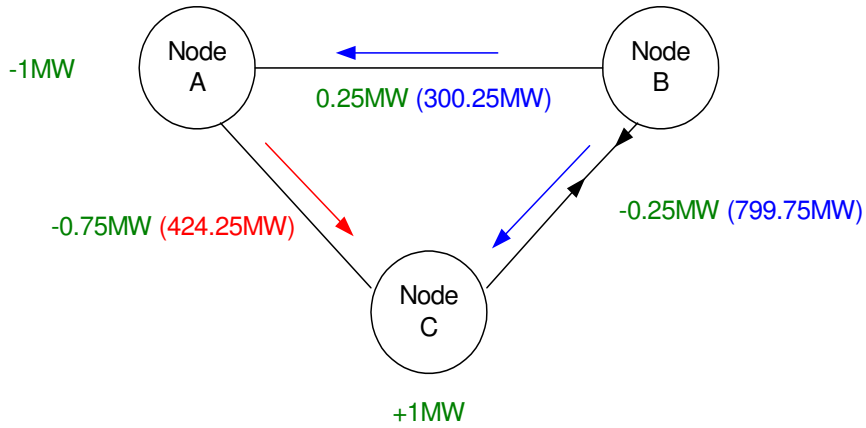

To calculate the relevant Peak Security and Year Round marginal km for node C:

Total Peak Security Cost =  $(300.25 \times 6) + (799.75 \times 26) = 22,595 \text{ MWkm}$

Total Year Round Cost =  $424.25 \times 10 = 4,242.5 \text{ MWkm}$

Marginal Peak Security cost = Incremental total Peak Security cost – Base case total Peak Security cost  
 $= 22595 - 22600 = -5 \text{ MWkm}$

Marginal Year Round cost = Incremental total Year Round cost – Base case total Year Round cost  
 $= 4242.5 - 4250 = -7.5 \text{ MWkm}$

Thus, the overall cost has reduced by 5 for Peak Security (i.e. the Peak Security marginal km = -5) and by 7.5 for Year Round (i.e. the Year Round marginal km = -7.5)

- Deleted: ¶
- Deleted: at
- Deleted:  $449.25 \times 10) + (50$
- Deleted: 549
- Deleted: 19,087

- Deleted: 12.
- Deleted: 12.5), ¶



### 14.22 Illustrative Calculation of Boundary Sharing Factors (BSFs) and Shared / Not-Shared incremental km

Formatted: Font: Arial Bold, 15 pt, Bold, Font color: Dark Blue, Highlight

Formatted: Highlight

Formatted: Highlight

The following illustrative example shows how the boundary sharing factors and shared / not-shared incremental km are calculated for the transmission system described in the table below.

Formatted: Highlight

Generation Charging Zone	A	B	C	D
Zonal MWkm	450	350	150	100

Formatted: Highlight

Formatted: Highlight

The diagram below shows the expanded connectivity of this transmission system.

Deleted: 14.22 Sharing of Year Round Marginal km costs

Formatted: Highlight

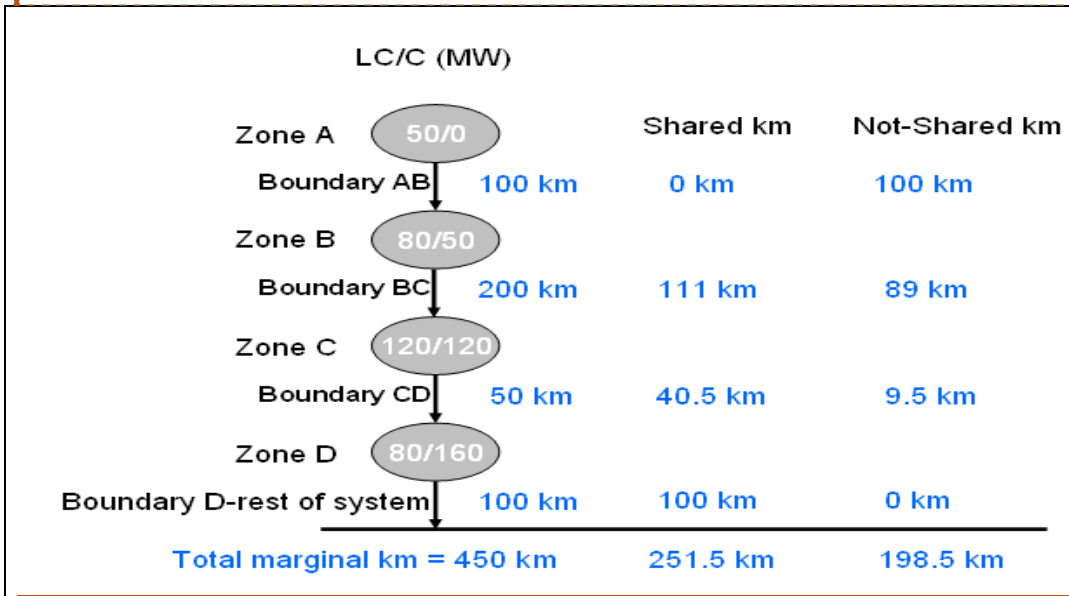

up

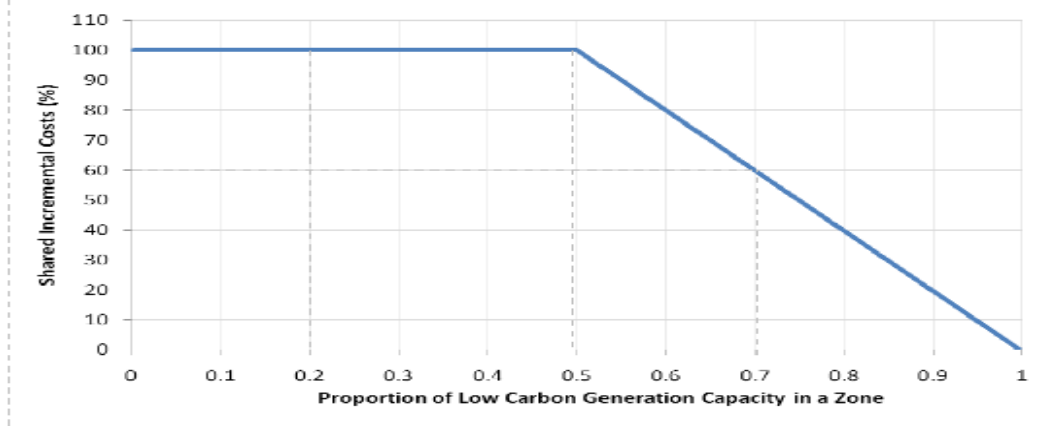

The above figure illustrates how the Year Round marginal km are split into Shared and Not-Shared.

Formatted: Highlight

Formatted: Highlight

(a) For Boundary AB (where 50MW of the generation is Low Carbon (LC) and 0MW of the generation is Carbon (C) and Year Round boundary marginal km = 100km) -

$\frac{LC}{(LC+C)} = \frac{50}{50+0} = 1$  which is greater than 0.5, therefore the following formula will be used to calculate the Boundary Sharing Factor (BSF) -

$$BSF = -2 \times \left( \frac{LC}{LC+C} \right) + 2 = -2 \times \left( \frac{50}{50+0} \right) + 2 = 0 (0\%)$$

Year Round Shared marginal km =  $0.0 * 100\text{km} = 0 \text{ km}$   
 Year Round Not-Shared marginal km =  $(100 - 0)\text{km} = 100 \text{ km}$

(b) For Boundary BC (where 130MW of generation is Low Carbon (LC) and 50MW of generation is Carbon (C) and Year Round boundary marginal km = 200km) -

$\frac{LC}{(LC+C)} = \frac{(50+80)}{(50+80)+(0+50)} = 0.722$  which is greater than 0.5, therefore the following formula will be used to the BSF -

$$BSF = -2 \times \left( \frac{LC}{LC+C} \right) + 2 = -2 \times \left( \frac{130}{130+50} \right) + 2 = 0.556 (55.6\%)$$

Year Round Shared marginal km =  $0.556 * 200\text{km} = 111 \text{ km}$   
 Year Round Not-Shared marginal km =  $(200 - 111)\text{km} = 89 \text{ km}$

(c) For Boundary CD (where 250MW of generation is Low Carbon (LC) and 170MW of generation is Carbon (C) and Year Round boundary marginal km = 50km) -

$\frac{LC}{(LC+C)} = \frac{(50+80+120)}{(50+80+120)+(0+50+120)} = 0.595$  which is greater than 0.5, therefore the following formula will be used to calculate the BSF -

$$BSF = -2 \times \left( \frac{LC}{LC+C} \right) + 2 = -2 \times \left( \frac{250}{250+170} \right) + 2 = 0.810 (81\%)$$

Year Round Shared marginal km =  $0.81 * 50\text{km} = 40.5 \text{ km}$   
 Year Round Not-Shared marginal km =  $(50 - 40.5)\text{km} = 9.5 \text{ km}$

(d) For Boundary D-rest of system (where 330MW of generation is Low Carbon (LC) and 330MW of generation is Carbon (C) and Year Round boundary marginal km = 100km) -

$\frac{LC}{(LC+C)} = \frac{(50+80+120+80)}{(50+80+120+80)+(0+50+120+160)} = 0.5$  therefore it is at the threshold at which maximum sharing occurs between LC and C generation. Therefore 100% of the Year Round zonal marginal km will be shared. (i.e. BSF=1.0);

Year Round Shared marginal km =  $1.0 * 100 = 100 \text{ km}$   
 Year Round Not-Shared marginal km =  $(100 - 100)\text{km} = 0 \text{ km}$

The shared zonal marginal km for each generation charging zone will be the sum of the relevant shared boundary marginal km as shown in the table below (assuming the node below D is the

- Formatted ... [21]
- Deleted: zonal ... [22]
- Formatted ... [23]
- Formatted ... [24]
- Deleted: X i.e. the % a ... [25]
- Formatted ... [26]
- Formatted ... [27]
- Formatted ... [28]
- Formatted ... [29]
- Formatted ... [30]
- Formatted ... [31]
- Formatted ... [32]
- Formatted ... [33]
- Deleted: zonal... [34]
- Formatted ... [35]
- Formatted ... [36]
- Deleted: calculate X i.e. ... [37]
- Formatted ... [38]
- Formatted ... [39]
- Formatted ... [40]
- Formatted ... [41]
- Formatted ... [42]
- Deleted: zonal ... [43]
- Formatted ... [44]
- Formatted ... [45]
- Deleted: X i.e. the % a ... [46]
- Formatted ... [47]
- Formatted ... [48]
- Formatted ... [49]
- Formatted ... [50]
- Formatted ... [51]
- Formatted ... [52]
- Formatted ... [53]
- Formatted ... [54]
- Formatted ... [55]
- Formatted ... [56]
- Deleted: b ... [57]
- Formatted ... [58]
- Formatted ... [59]
- Formatted ... [60]
- Formatted ... [61]
- Formatted ... [62]
- Formatted ... [63]
- Formatted ... [64]
- Formatted ... [65]
- Formatted ... [66]
- Formatted ... [67]
- Formatted ... [68]

centre of the system i.e. zonal MWkm of 0). These not-shared zonal incremental km are then use to calculate wider £/kW generation tariffs.

**Formatted:** Font: Not Bold, Font color: Auto, Highlight

**Formatted:** Font: Not Bold, Font color: Auto, Highlight

**Formatted:** Highlight

Boundary/Zone	A	B	C	D
A-B	0			
B-C	111	111		
C-D	40.5	40.5	40.5	
D-rest of system	100	100	100	100
Shared Zonal MWkm	251.5	251.5	140.5	100
Total Zonal MWkm	450	350	150	100

The not-shared zonal marginal km for each generation charging zone will be the sum of the relevant not-shared boundary marginal km as shown in the table below (assuming the node below D is the centre of the system i.e. zonal MWkm of 0). These not-shared zonal incremental km are then use to calculate wider £/kW generation tariffs.

**Formatted:** Highlight

**Formatted:** Font: Not Bold, Font color: Auto, Highlight

**Formatted:** Font: Not Bold, Font color: Auto, Highlight

**Formatted:** Font: Not Bold, Font color: Auto, Highlight

**Formatted:** Font: Not Bold, Font color: Auto, Highlight

**Formatted:** Font: Not Bold, Font color: Auto, Highlight

**Formatted:** Highlight

Boundary/Zone	A	B	C	D
A-B	100			
B-C	89	89		
C-D	9.5	9.5	9.5	
D-rest of system	0	0	0	0
Not-Shared Zonal MWkm	198.5	98.5	9.5	0
Total Zonal MWkm	450	350	150	100

### 14.23 Example: Calculation of Zonal Generation Tariffs and Charges

#### Wider

Let us consider all nodes in a generation zone in this example

The table below shows a sample output of the transport model comprising the node, the Peak Security wider nodal marginal km and Year Round wider nodal marginal km (observed on non-local assets) of an injection at the node with a consequent withdrawal across distributed reference node, the generation sited at the node, scaled to ensure total national generation equals total national demand, for both Peak Security and Year Round generation backgrounds.

Gen Zone	Node	Wider Nodal Marginal km (Peak Security)	Scaled Generation (Peak Security)	Wider Nodal Marginal km (Year Round)	Scaled Generation (Year Round)
4	ABNE10	5.73	0.00	459.90	0.00
4	CLAY1S	239.67	0.00	306.47	0.00
4	CLUN1S	46.41	22.90	502.16	18.76
4	COUA10	45.39	0.00	423.30	0.00
4	DYCE1Q	162.70	0.00	357.81	0.00
4	ERRO10	46.82	56.13	534.03	45.99
4	FIDD1B	91.88	0.00	220.59	0.00
4	FINL1Q	79.69	12.35	495.63	10.12
4	GRIF1S	33.31	0.00	521.16	71.40
4	KIIN10	79.69	0.00	495.63	0.00
4	LOCH10	79.69	35.18	495.63	28.82
4	MILC10	117.69	0.00	328.86	0.00
4	PERS20	266.00	0.00	384.05	0.00
4	TUMB1Q	46.82	0.00	536.27	0.00
	<b>Totals</b>		<b>126.56</b>		<b>175.09</b>

In order to calculate the generation tariff we would carry out the following steps.

- (i) calculate the generation weighted wider nodal shadow costs.

For this example zone this would be as follows:

Gen Zone	Node	Wider Nodal Marginal km (Peak Security)	Scaled Generation (Peak Security) (MW)	Gen Weighted Wider Nodal Marginal km (Peak Security)	Wider Nodal Marginal km (Year Round)	Scaled Generation (Year Round) (MW)
4	CLUN1S	46.41	22.90	8.39	502.16	18.76
4	ERRO10	46.82	56.13	20.76	534.03	45.99
4	FINL1Q	79.69	12.35	7.77	495.63	10.12
4	GRIF1S	N/A	N/A	N/A	521.16	71.40
4	LOCH10	79.69	35.18	22.15	495.63	28.82
	<b>Totals</b>		<b>126.56</b>			<b>175.09</b>

i.e.  $79.69 \times 35.18$   
126.56

Deleted: ¶

Deleted: 2

Deleted: 4

Deleted: 4: Western Highland.¶

Deleted: at the

Deleted: ¶ Genzone ... [69]

Deleted: 4

Deleted: Genzone ... [70]

Deleted: <sp>

Deleted: ¶

sum the generation weighted wider nodal shadow cost to give a zonal figure.¶

21

£

(ii) sum the generation weighted wider nodal shadow costs to give Peak Security and Year Round zonal figures.

For this example zone this would be:

Peak Security: (8.39 + 20.76 + 7.77 + 22.15) km = 59.07 km

Year Round: (53.80 + 140.27 + 28.65 + 212.52 + 81.58) km = 516.82 km

(iii) In this example we have assumed that accounting for sharing in the Year Round background gives:

Year Round Shared marginal km = 344.56km

Year Round Not-Shared marginal km = 172.26km

(iv) calculate the initial Peak Security wider transport tariff, Year Round Shared wider transport tariff and Year Round Not-Shared wider transport tariff by multiplying the figures in (iii) above by the expansion constant (& dividing by 1000 to put into units of £/kW).

For zone 4 and assuming an expansion constant of £10.07/MWkm and a locational security factor of 1.8:

a) Initial Peak Security wider tariff -

$$\frac{59.07 \text{ km} * \text{£}10.07/\text{MWkm} * 1.8}{1000} = \text{£}1.071/\text{kW}$$

b) Initial Year Round Shared wider tariff -

$$\frac{344.56 \text{ km} * \text{£}10.07/\text{MWkm} * 1.8}{1000} = \text{£}6.245/\text{kW}$$

c) Initial Year Round Not-Shared wider tariff -

$$\frac{172.26 \text{ km} * \text{£}10.07/\text{MWkm} * 1.8}{1000} = \text{£}1.309/\text{kW}$$

**Local**

(v) If we assume (for the sake of this example) that the generator connecting at CLUN1S is a thermal plant with a Peak Security flag of 1 and an Annual Load Factor (ALF) of 60%, which connects via 10km of 132kV 100MVA rated single circuit overhead line from the nearest MITS node, with no redundancy, the substation is rated at less than 1320MW, and there is no other generation or demand connecting to this circuit, then:

a) referencing the table in paragraph 14.15.106, the local substation tariff will be £0.133/kW; and

b) running the transport model with a local circuit expansion factor of 10.0 applied to the 10km of overhead line connecting CLUN1S to the nearest MITS node and the wider circuit expansion factors applied to all other circuits, gives a local nodal maginal cost of 100MWkm. This is the additional MWkm costs associated with the node's local assets. Applying the expansion constant of £10.07/MWkm and local security factor of 1.0 and dividing by 1000 gives a local circuit tariff of £1.007/kW.

**Residual**

Deleted: 4

Deleted: (366.48+ 261.75 +290.71 + 108.... + 100.67...1127.81km¶

¶

¶ modify the zonal figure in (ii) above by the generation/demand split correction factor. This ensures that the 27:73 (approx) split of revenue recovery between generation and demand is retained.¶

¶ ... [71]

Deleted: ) = 888.21

Formatted: ... [72]

Formatted: ... [73]

Formatted: ... [74]

Deleted: calculate the ... [75]

Formatted: No underline

Formatted: Highlight

Formatted: ... [76]

Formatted: ... [77]

Formatted: ... [78]

Formatted: ... [79]

Formatted: Highlight

Deleted: ¶ ... [80]

Formatted: Highlight

Formatted: ... [81]

Formatted: ... [82]

Formatted: ... [83]

Deleted: 66.67% \* 516.82km =

Formatted: Highlight

Deleted: (516.82 - 344 ... [84]

Formatted: Highlight

Deleted: ¶

Formatted: Font: Not Bold

Formatted: ... [85]

Deleted: figure...i ... [86]

Deleted: 888.21

Formatted: ... [87]

Deleted: 6.10

Deleted: .

Formatted: ... [88]

Formatted: Bullets and Numbering ... [89]

Formatted: ... [90]

Formatted: ... [91]

Formatted: Bullets and Numbering ... [92]

Deleted: generation... [93]

Deleted: 67

Deleted: CEAN1Q

(vi) We now need to calculate the residual tariff. This is calculated by taking the total revenue to be recovered from generation (calculated as c.27% of total The Company TNUoS target revenue for the year) less the revenue which would be recovered through the generation transport tariffs divided by total expected generation.

**Formatted:** Indent: Left: 0 cm  
**Formatted:** Bullets and Numbering

Assuming the total revenue to be recovered from TNUoS is £1067m, the total recovery from generation would be (27% x £1067m) = £288m. Assuming the total recovery from both wider generation transport tariffs (i.e. wider Peak Security tariff, wider Year Round Shared tariff and wider Year Round Not-Shared tariff) and local generation tariffs (i.e. local substation tariff and local circuit tariff) is £70m and total forecast chargeable generation capacity is 67000MW, the Generation residual tariff would be as follows:

$$\frac{£288 - £70m}{65000MW} = £3.35/kW$$

**Formatted:** Centered  
**Deleted:** to get to  
**Deleted:** final tariff  
**Deleted:** generator

(vii) Therefore the charges for thermal plant with a TEC of 100MW and an ALF of 60% connecting at CLUN1S is:

**Deleted:** a particular node, we simply sum the generation residual tariff calculated in (vi), the wider zonal transport tariff calculated in (iv), the local substation tariff calculated in (v(a)), and the local circuit tariff calculated in (v(b)). In

- = Wider Peak Security Tariff \* PS Flag \* TEC
- = Wider Year Round Shared Tariff \* ALF \* TEC
- = Wider Year Round Not-Shared Tariff \* TEC
- = Local substation Tariff \* TEC
- = Local circuit Tariff \* TEC
- = Residual Tariff \* TEC

**Formatted:** Highlight  
**Formatted:** Highlight  
**Formatted:** Highlight

For this example, the above charges are –

**Deleted:** ¶  
 . For CEAN1Q : . £16.10/kW + £3.35/kW + £

- = 1.071 \* 1 \* 100,000
- = 6.245 \* 0.6 \* 100,000
- = 1.309 \* 100,000
- = 0.133 \* 100,000
- = 1.007 \* 100,000
- = 3.35 \* 100,000

**Formatted:** Highlight  
**Formatted:** Font color: Auto, English (U.K.), Do not check spelling or grammar, Highlight

(effectively, £10.617/kW \* 100,000kW = £1,061,700)

**Deleted:** 135/kW + £  
**Formatted:** Highlight

(viii) Alternatively, if we assume that the generator connecting at CLUN1S is an intermittent wind generation plant (instead of a thermal plant) with a TEC of 100MW, PS Flag of 0 and an ALF of 30%, then the charges payable will be –

**Formatted:** Highlight  
**Formatted:** Highlight

- = 1.071 \* 0 \* 100,000
- = 6.245 \* 0.3 \* 100,000
- = 1.309 \* 100,000
- = 0.133 \* 100,000
- = 1.007 \* 100,000
- = 3.35 \* 100,000

**Formatted:** Left, Indent: Left: 0.25 cm  
**Formatted:** English (U.K.)  
**Deleted:** /kW = £20.592 /kW

(effectively, £7.673/kW \* 100,000kW = £767,300)

**Formatted:** English (U.K.)  
**Deleted:** ¶  
 To summarise, in order to calculate the generation tariffs, we evaluate a generation weighted zonal marginal km cost, modify by a re-referencing quantity to ensure that our revenue recovery split between generation and demand is correct, multiply by the security factor, then we add a constant (termed the residual cost) to give the overall tariff. ¶  
 -----Page Break-----

**Formatted:** Highlight  
**Formatted:** Highlight  
**Formatted:** Highlight

## 14.24 Example: Calculation of Zonal Demand Tariff

Deleted: 3

Let us consider all nodes in a demand zone [in this example](#).

Deleted: 14: South Western

The table below shows a sample output of the transport model comprising the node, the [Peak Security and Year Round](#) marginal km of an injection at the node with a consequent withdrawal at the [distributed](#) reference node, the generation sited at the node, scaled to ensure total national generation = total national demand and the demand sited at the node.

Deleted: ¶  
Demand Zone

... [94]

<u>Demand Zone</u>	<u>Node</u>	<u>Peak Security Nodal Marginal</u> km	<u>Year Round Nodal Marginal</u> km	<u>Demand (MW)</u>
14	ABHA4A	-77.25	-230.25	127
14	ABHA4B	-77.27	-230.12	127
14	ALVE4A	-82.28	-197.18	100
14	ALVE4B	-82.28	-197.15	100
14	AXMI40 SWEB	-125.58	-176.19	97
14	BRWA2A	-46.55	-182.68	96
14	BRWA2B	-46.55	-181.12	96
14	EXET40	-87.69	-164.42	340
14	HINP20	-46.55	-147.14	0
14	HINP40	-46.55	-147.14	0
14	INDQ40	-102.02	-262.50	444
14	IROA20 SWEB	-109.05	-141.92	462
14	LAND40	-62.54	-246.16	262
14	MELK40 SWEB	18.67	-140.75	83
14	SEAB40	65.33	-140.97	304
14	TAUN4A	-66.65	-149.11	55
14	TAUN4B	-66.66	-149.11	55
	<b>Totals</b>			<b>2748</b>



In order to calculate the demand tariff we would carry out the following steps:

- (i) calculate the demand weighted nodal shadow costs

For this example zone, this would be as follows:

Deleted: 14

Deleted: Demand zone( ... [95]

<u>Demand zone</u>	<u>Node</u>	<u>Peak Security Nodal Marginal km</u>	<u>Year Round Nodal Marginal km</u>	<u>Demand (MW)</u>	<u>Peak Security Demand Weighted Nodal Marginal km</u>	<u>Year Round Demand Weighted Nodal Marginal km</u>
14	ABHA4A	-77.25	-230.25	127	-3.57	-10.64
14	ABHA4B	-77.27	-230.12	127	-3.57	-10.64
14	ALVE4A	-82.28	-197.18	100	-2.99	-7.17
14	ALVE4B	-82.28	-197.15	100	-2.99	-7.17
14	AXMI40 SWEB	-125.58	-176.19	97	-4.43	-6.22
14	BRWA2A	-46.55	-182.68	96	-1.63	-6.38
14	BRWA2B	-46.55	-181.12	96	-1.63	-6.33
14	EXET40	-87.69	-164.42	340	-10.85	-20.34
14	INDQ40	-102.02	-262.50	444	-16.48	-42.41
14	IROA20 SWEB	-109.05	-141.92	462	-18.33	-23.86
14	LAND40	-62.54	-246.16	262	-5.96	-23.47
14	MELK40 SWEB	18.67	-140.75	83	0.56	-4.25
14	SEAB40	65.33	-140.97	304	7.23	-15.59
14	TAUN4A	-66.65	-149.11	55	-1.33	-2.98
14	TAUN4B	-66.66	-149.11	55	-1.33	-2.98
	<b>Totals</b>			<b>2748</b>	<b>-49.19</b>	<b>-190.43</b>

- (ii) sum the Peak Security and Year Round demand weighted nodal shadow costs to give zonal figures. For this example zone this is shown in the above table and is 49.19km for Peak Security background and 190.43km for Year Round background.

Deleted: 14

- (iii) calculate the transport tariffs by multiplying the figures in (ii) above by the expansion constant (& dividing by 1000 to put into units of £/kW):

For this example zone, assuming an expansion constant of £10.07/MWkm and a locational security factor of 1.80:

Deleted: 14

a) Peak Security tariff -  

$$\frac{49.19\text{km} * \text{£}10.07/\text{MWkm} * 1.8}{1000} = \text{£}0.89/\text{kW}$$

Deleted: .527.59km

Deleted: 9.56

Deleted: .

b) Year Round tariff -  

$$\frac{190.43\text{km} * \text{£}10.07/\text{MWkm} * 1.8}{1000} = \text{£}3.45/\text{kW}$$

- (iv) We now need to calculate the residual tariff. This is calculated by taking the total revenue to be recovered from demand (calculated as c.73% of total The Company TNUoS target revenue for the year) less the revenue which would be recovered through the demand transport tariffs divided by total expected demand.

Assuming the total revenue to be recovered from TNUoS is £1067m, the total recovery from demand would be (73% x £1067m) = £779m. Assuming the total recovery from

demand transport tariffs is £130m and total forecast chargeable demand capacity is 50000MW, the demand residual tariff would be as follows:

$$\frac{£779m - £130m}{50000MW} = \underline{£12.98/kW}$$

(v) to get to the final tariff, we simply add on the demand residual tariff calculated in (iv) to the zonal transport tariffs calculated in (iii(a)) and (iii(b))

For zone 14:

$$\underline{£0.89/kW} + \underline{£3.45/kW} + \underline{£12.98/kW} = \underline{£17.32/kW}$$

To summarise, in order to calculate the demand tariffs, we evaluate a demand weighted zonal marginal km costs, multiply by the expansion constant and locational security factor, then we add a constant (termed the residual cost) to give the overall tariff.

(vi) The final demand tariff is subject to further adjustment to allow for the minimum £0/kW demand charge. The application of a discount for small generators pursuant to Licence Condition C13 will also affect the final demand tariff.

- Deleted: tariff
- Deleted: iv)
- Formatted: Dutch (Belgium)
- Formatted: Dutch (Belgium)
- Deleted: £9.56
- Formatted: Dutch (Belgium)
- Deleted: 22.54
- Formatted: Dutch (Belgium)
- Formatted: Dutch (Belgium)
- Formatted: Dutch (Belgium)
- Deleted: , modify
- Deleted: a re-referencing quantity to ensure that our revenue recovery split between generation and demand is correct
- Deleted: i
- Formatted: Check spelling and grammar
- Formatted: Indent: Left: 1.27 cm
- Formatted: Left, Indent: Left: 0 cm

## 14.25 Reconciliation of Demand Related Transmission Network Use of System Charges

Deleted: .....

14.24

Formatted: Font: Arial, Font color: Dark Blue

Deleted: 4

This appendix illustrates the methodology used by The Company in the reconciliation of Transmission Network Use of System charges for demand. The example highlights the different stages of the calculations from the monthly invoiced amounts, right through to Final Reconciliation.

### Monthly Charges

Suppliers provide half-hourly (HH) and non-half-hourly (NHH) demand forecasts by BM Unit every quarter. An example of such forecasts and the corresponding monthly invoiced amounts, based on tariffs of £10.00/kW and 1.20p/kWh, is as follows:

	Forecast HH Triad Demand $HHD_F(kW)$	HH Monthly Invoiced Amount (£)	Forecast NHH Energy Consumption $NHHC_F(kWh)$	NHH Monthly Invoiced Amount (£)	Net Monthly Invoiced Amount (£)
Apr	12,000	10,000	15,000,000	15,000	25,000
May	12,000	10,000	15,000,000	15,000	25,000
Jun	12,000	10,000	15,000,000	15,000	25,000
Jul	12,000	10,000	18,000,000	19,000	29,000
Aug	12,000	10,000	18,000,000	19,000	29,000
Sep	12,000	10,000	18,000,000	19,000	29,000
Oct	12,000	10,000	18,000,000	19,000	29,000
Nov	12,000	10,000	18,000,000	19,000	29,000
Dec	12,000	10,000	18,000,000	19,000	29,000
Jan	7,200	(6,000)	18,000,000	19,000	13,000
Feb	7,200	(6,000)	18,000,000	19,000	13,000
Mar	7,200	(6,000)	18,000,000	19,000	13,000
Total		72,000		216,000	288,000

As shown, for the first nine months the Supplier provided a 12,000kW HH triad demand forecast, and hence paid HH monthly charges of £10,000  $((12,000kW \times £10.00/kW)/12)$  for that BM Unit. In January the Supplier provided a revised forecast of 7,200kW, implying a forecast annual charge reduced to £72,000  $(7,200kW \times £10.00/kW)$ . The Supplier had already paid £90,000, so the excess of £18,000 was credited back to the supplier in three £6,000 instalments over the last three months of the year.

The Supplier also initially provided a 15,000,000kWh NHH energy consumption forecast, and hence paid NHH monthly charges of £15,000  $((15,000,000kWh \times 1.2p/kWh)/12)$  for that BM Unit. In July the Supplier provided a revised forecast of 18,000,000kWh, implying a forecast annual charge increased to £216,000  $(18,000,000kWh \times 1.2p/kWh)$ . The Supplier had already paid £45,000, so the remaining £171,000 was split into payments of £19,000 for the last nine months of the year.

The right hand column shows the net monthly charges for the BM Unit.

### Initial Reconciliation (Part 1)

The Supplier's outturn HH triad demand, based on initial settlement data (and therefore subject to change in subsequent settlement runs), was 9,000kW. The HH triad demand reconciliation charge is therefore calculated as follows:

$$\text{HHD Reconciliation Charge} = (\text{HHD}_A - \text{HHD}_F) \times \text{£/kW Tariff}$$

$$= (9,000\text{kW} - 7,200\text{kW}) \times \text{£}10.00/\text{kW}$$

$$= 1,800\text{kW} \times \text{£}10.00/\text{kW}$$

$$= \text{£}18,000$$

**Formatted:** Font: Not Bold, Font color: Auto

**Formatted:** Font: Not Bold, Font color: Auto

**Formatted:** Font: Not Bold, Font color: Auto

**Formatted:** Font: Not Bold, Font color: Auto

To calculate monthly interest charges, the outturn HHD charge is split equally over the 12-month period. The monthly reconciliation amount is the monthly outturn HHD charge less the HH monthly invoiced amount. Interest payments are calculated based on these monthly reconciliation amounts using Barclays Base Rate.

Please note that payments made to BM Units with a net export over the Triad, based on initial settlement data, will also be reconciled at this stage.

As monthly payments will not be made on the basis of a negative forecast, the HHD Reconciliation Charge for an exporting BM Unit will represent the full actual payment owed to that BM Unit (subject to adjustment by subsequent settlement runs). Interest will be calculated as described above.

### Initial Reconciliation (Part 2)

The Supplier's outturn NHH energy consumption, based on initial settlement data, was 17,000,000kWh. The NHH energy consumption reconciliation charge is therefore calculated as follows:

$$\text{NHH Reconciliation Charge} = \frac{(\text{NHH}_A - \text{NHH}_F)}{100} \times \text{p/kWh Tariff}$$

$$= \frac{(17,000,000\text{kWh} - 18,000,000\text{kWh})}{100} \times 1.20\text{p/kWh}$$

$$= \frac{-1,000,000\text{kWh}}{100} \times 1.20\text{p/kWh}$$

$$= \text{-£}12,000$$

**Formatted:** Font: Not Bold, Font color: Auto

**Formatted:** Font: Not Bold, Font color: Auto

**Formatted:** Font: Not Bold, Font color: Auto

[worked example 4.xls - Initial!J104](#)

The monthly reconciliation amount is equal to the outturn energy consumption charge for that month less the NHH monthly invoiced amount. Interest payments are calculated based on the monthly reconciliation amounts using Barclays Base Rate.

The net initial TNUoS demand reconciliation charge is therefore £6,000 (£18,000 - £12,000).

### Final Reconciliation

Finally, let us now suppose that after all final Settlement data has been received (up to 14 months after the relevant dates), the outturn HH triad demand and NHH energy consumption values were 9,500kW and 16,500,000kWh, respectively.

$$\begin{aligned} \text{Final HH Reconciliation Charge} &= (9,500\text{kW} - 9,000\text{kW}) \times \text{£}10.00/\text{kW} \\ &= \text{£}5,000 \end{aligned}$$

$$\begin{aligned} \text{Final NHH Reconciliation Charge} &= \frac{(16,700,000\text{kWh} - 17,000,000\text{kWh}) \times 1.20\text{p}/\text{kWh}}{100} \\ &= -\text{£}3,600 \end{aligned}$$

Consequently, the net final TNUoS demand reconciliation charge will be £1,400.

Interest payments are calculated based on the monthly reconciliation amounts using Barclays Base Rate.

Outturn data for BM Units with a net export over the Triad will be received at this stage and final reconciliation will be carried out, as required. Interest will be calculated as described above.

### Terminology:

**HHD<sub>A</sub>** = The Supplier's outturn half-hourly metered Triad Demand (kW) for the demand zone concerned.

**HHD<sub>F</sub>** = The Supplier's forecast half-hourly metered Triad Demand (kW) for the demand zone concerned.

**NHHC<sub>A</sub>** = The Supplier's outturn non-half-hourly metered daily Energy Consumption (kWh) for the period 16:00 hrs to 19:00 hrs inclusive (i.e. settlement periods 33 to 38) from April 1<sup>st</sup> to March 31<sup>st</sup>, for the demand zone concerned.

**NHHC<sub>F</sub>** = The Supplier's forecast non-half-hourly metered daily Energy Consumption (kWh) for the period 16:00 hrs to 19:00 hrs inclusive (i.e. settlement periods 33 to 38) from April 1<sup>st</sup> to March 31<sup>st</sup>, for the demand zone concerned.

**£/kW Tariff** = The £/kW Demand Tariff as shown in Schedule 1 of **The Statement of Use of System Charges** for the demand zone concerned.

**p/kWh Tariff** = The Energy Consumption Tariff shown in Schedule 1 of **The Statement of Use of System Charges** for the demand zone concerned.

## 14.26 Classification of parties for charging purposes

Deleted: 5

In the event of any conflict between this Appendix and the main text within this Statement, the main text within the Statement shall take precedence.

In the following diagrams, the parties liable for Transmission Network Use of System charges are outlined in red.

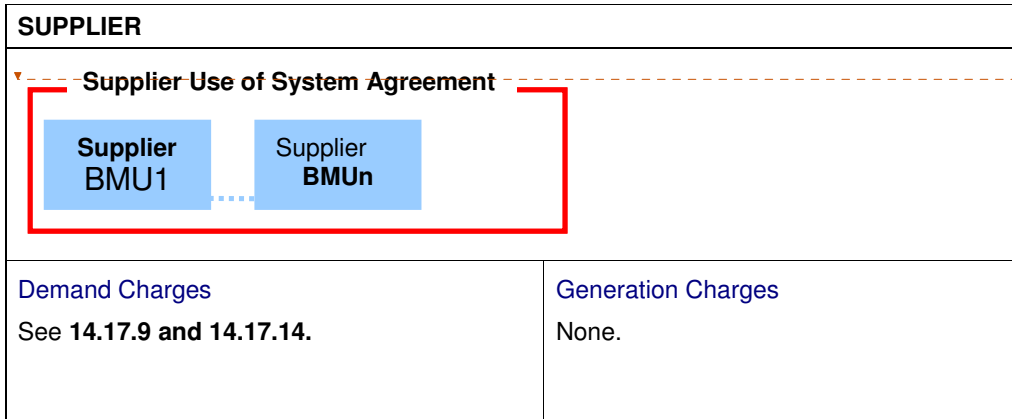

Deleted: ¶

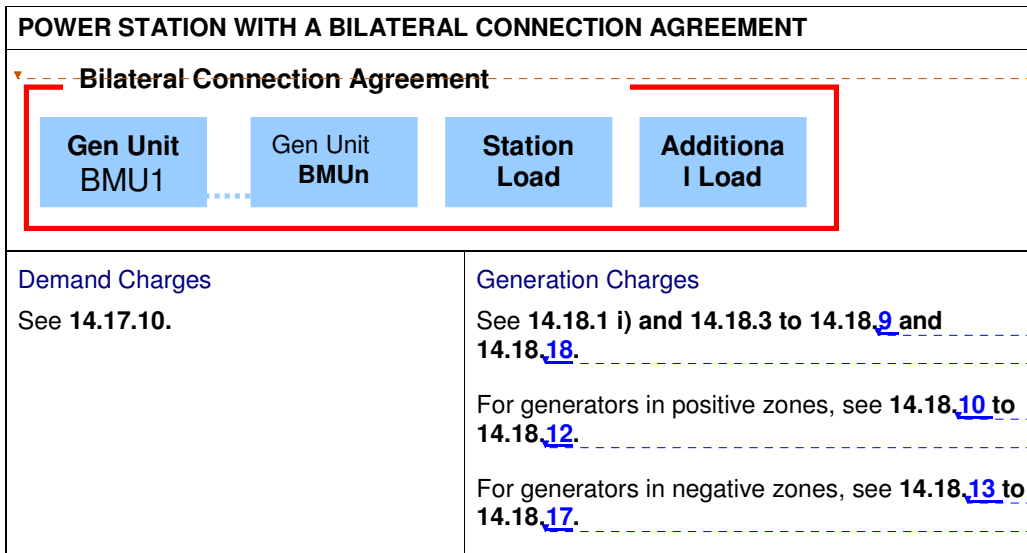

Deleted: ¶

¶  
¶  
¶  
¶

Deleted: 8

Deleted: 17

Deleted: 9

Deleted: 11

Deleted: 12

Deleted: 16

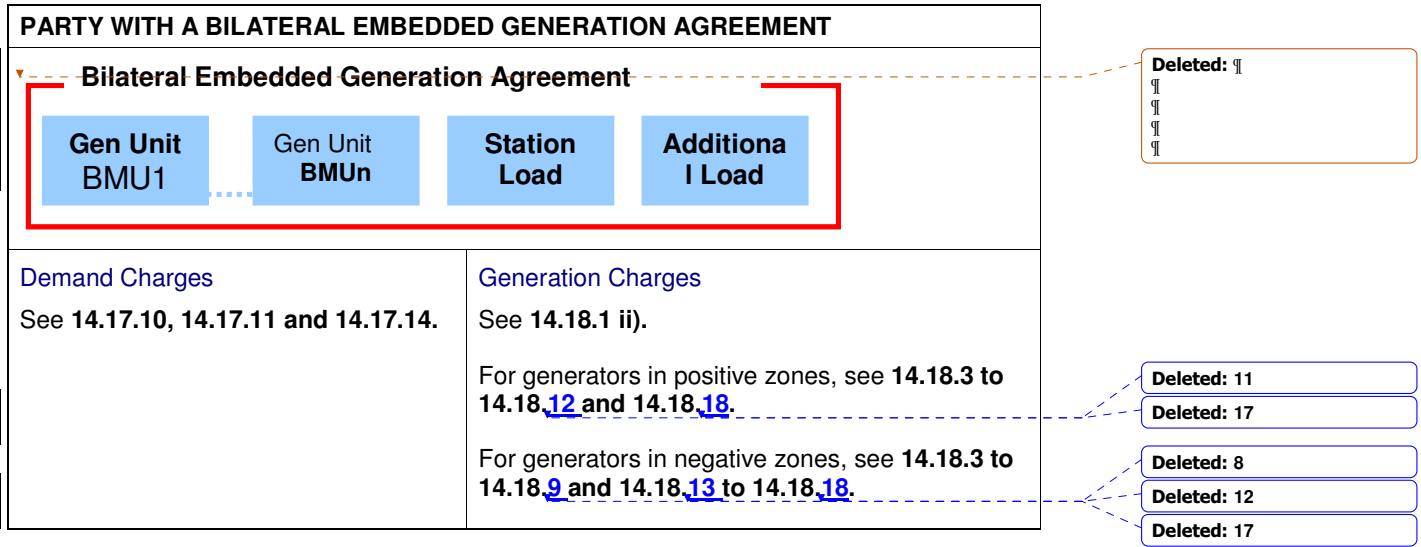

## 14.27 Transmission Network Use of System Charging Flowcharts

Deleted: 6

The following flowcharts illustrate the parties liable for Demand and Generation TNUoS charges and the calculation of those charges.

In the event of any conflict between this Appendix and the main text within this Statement, the main text within the Statement shall take precedence.

### Demand Charges

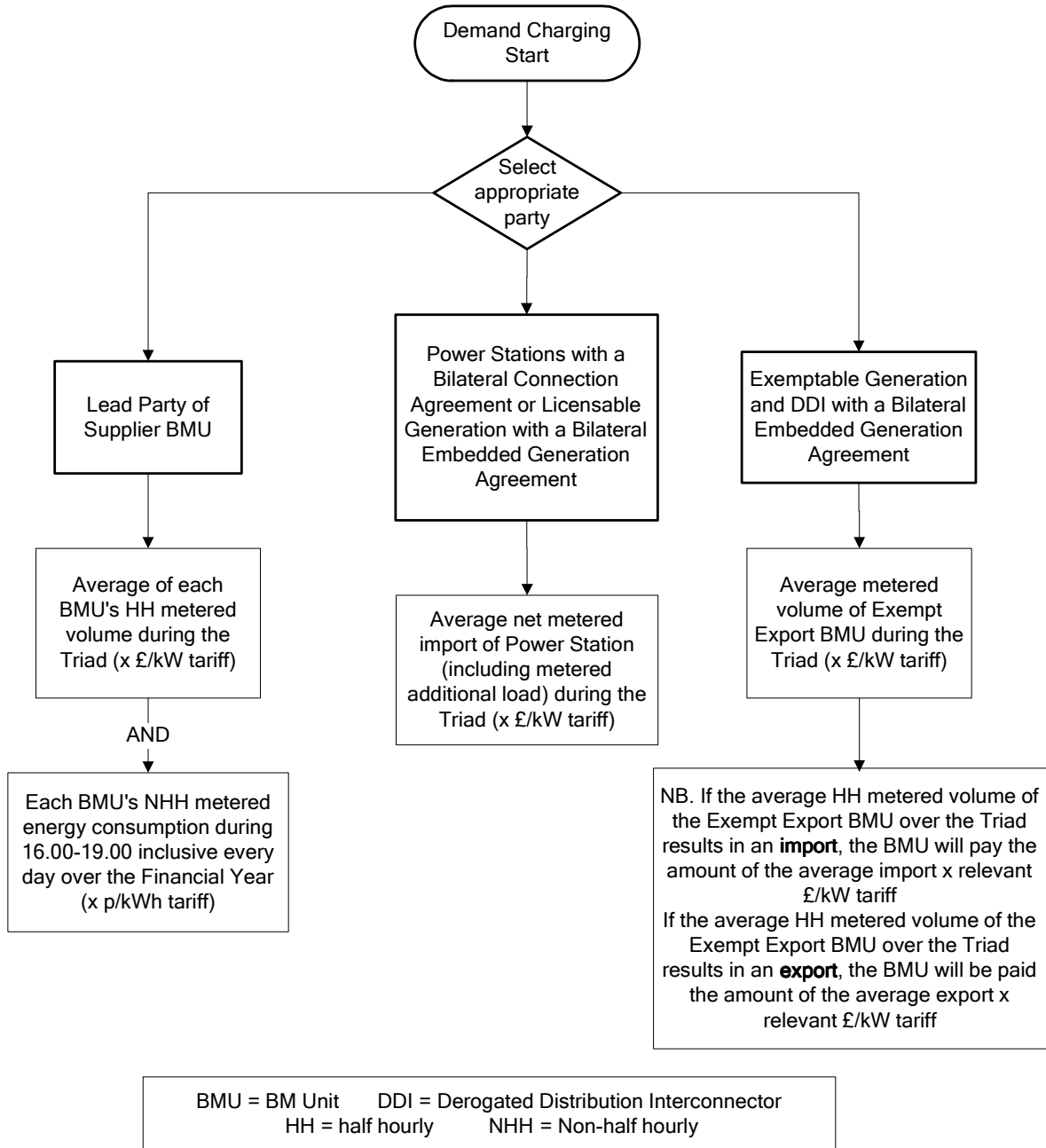



Generation Charges

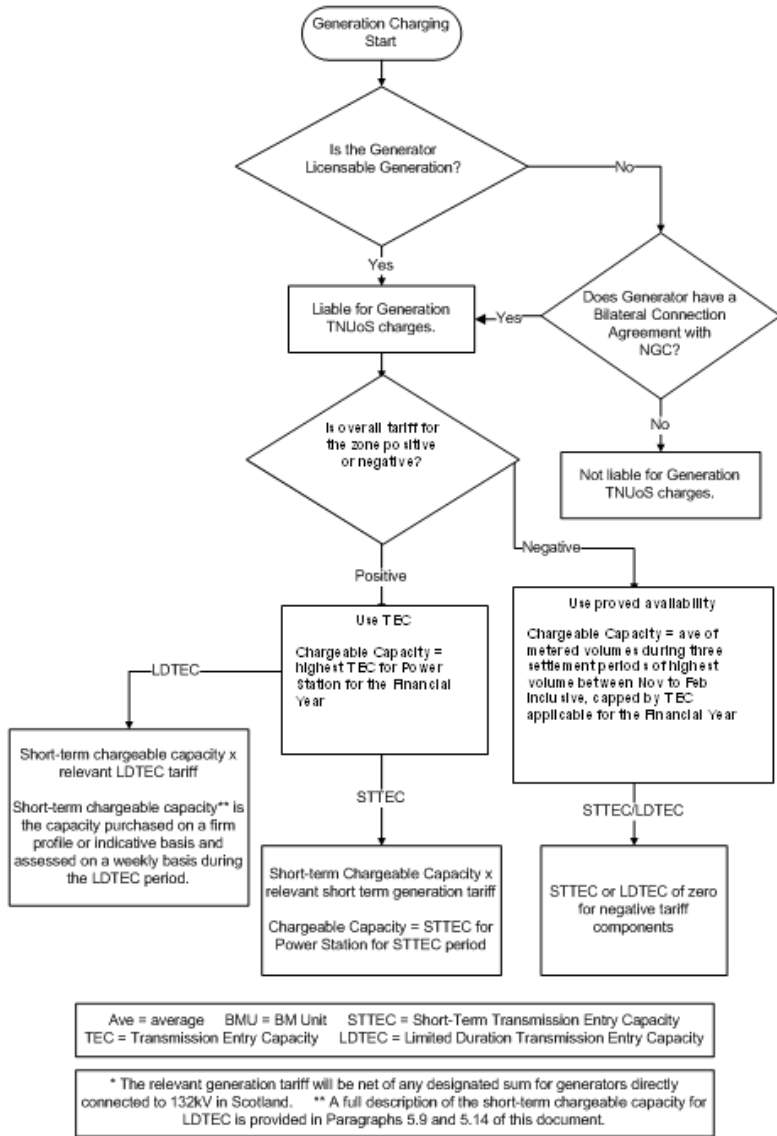

Ave = average BMU = BM Unit STTEC = Short-Term Transmission Entry Capacity  
 TEC = Transmission Entry Capacity LDTEC = Limited Duration Transmission Entry Capacity

\* The relevant generation tariff will be net of any designated sum for generators directly connected to 132kV in Scotland. \*\* A full description of the short-term chargeable capacity for LDTEC is provided in Paragraphs 5.9 and 5.14 of this document.

Short-term chargeable capacity x relevant LDTEC tariff  
 Short-term chargeable capacity\*\* is the capacity purchased on a firm profile or indicative basis and assessed on a weekly basis during the LDTEC period.

Ave  
TEC = T  
 \* Th  
connecte

Deleted:

## 14.28 Example: Determination of The Company's Forecast for Demand Charge Purposes

Deleted: 7

The Company will use the latest available settlement data for calculation of HH demand and NHH energy consumption forecasts for the Financial Year.

The Financial Year runs from 1<sup>st</sup> April to 31<sup>st</sup> March inclusive and for the purpose of these examples the year April 2005 to March 2006 is used.

Where the preceding year's settlement data is not available at the time that The Company needs to calculate its forecast, The Company will use settlement data from the corresponding period in Financial Year minus two unless indicated otherwise.

All values used with the examples are purely for illustrative purposes only.

### i) Half-Hourly (HH) Metered Demand Forecast – Existing User

At the time of calculation of a HH demand forecast before the relevant Financial Year (approximately 10<sup>th</sup> March), The Company will be aware at a system level which dates will be used for the determination of Triad. However, The Company may not have settlement data at a User level if the Triad dates were to span a period that includes the latter half of February.

When undertaking forecasting before the relevant Financial Year, The Company will use the User's Triad demand for the previous year for its forecast providing it holds User settlement data for this period, thus:

$$F = T$$

where:

F = Forecast of User's HH demand at Triad for the Financial Year

T = User's HH demand at Triad in Financial Year minus one

Where The Company determines its forecast within a Financial Year:

$$F = T * D/P$$

where:

F = Forecast of User's HH demand at Triad for the Financial Year

T = User's HH demand at Triad in the preceding Financial Year

D = User's average half hourly metered demand in settlement period 35 in the Financial Year to date

P = User's average half hourly metered demand in settlement period 35 for the period corresponding to D in the preceding Financial Year

Where The Company determines its forecast before the relevant Financial Year and User settlement data for the Triad period is not available, The Company shall apply the formula immediately above (within year forecast) but substitute the following definitions for the values T, D, and P:

T = User's HH demand at Triad in the Financial Year minus two

D = User's average half hourly metered demand in settlement period 35 in the Financial Year minus one, to date

P = User's average half hourly metered demand in settlement period 35 for the period corresponding to D in the Financial Year minus two

**Example** (where User settlement data is not yet available for the Triad period):

The Company calculates a HH demand forecast on the above methodology at 10<sup>th</sup> March 2005 for the period 1<sup>st</sup> April 2005 to 31<sup>st</sup> March 2006.

$$F = 10,000 * 13,200 / 12,000$$

$$F = 11,000 \text{ kWh}$$

where:

T = 10,000 kWh (period November 2003 to February 2004)

D = 13,200 kWh (period 1<sup>st</sup> April 2004 to 15<sup>th</sup> February 2005#)

P = 12,000 kWh (period 1<sup>st</sup> April 2003 to 15<sup>th</sup> February 2004)

# Latest date for which settlement data is available.

**ii) Non Half-Hourly (NHH) Metered Energy Consumption Forecast – Existing User**

$$F = E * D/P$$

where:

F = Forecast of User's NHH metered energy consumption for the Financial Year

E = User's summed NHH energy consumption over the hours 16:00 to 19:00 for each day in the preceding Financial Year

D = User's summed NHH energy consumption for the hours 16:00 to 19:00 for each day for the Financial Year to date

P = User's summed NHH energy consumption for the hours 16:00 to 19:00 for each day for the period corresponding to D in the preceding Financial Year

**Example:**

The Company calculates a NHH energy consumption forecast on the above methodology at 10<sup>th</sup> June 2005 for the period 1<sup>st</sup> April 2005 to 31<sup>st</sup> March 2006.

$$F = 50,000,000 * 4,400,000 / 4,000,000$$

$$F = 55,000,000 \text{ kWh}$$

where:

E = 50,000,000 kWh (period 1<sup>st</sup> April 2004 to 31<sup>st</sup> March 2005)

D = 4,400,000 kWh (period 1<sup>st</sup> April 2005 to 15<sup>th</sup> May 2005#)

P = 4,000,000 kWh (period 1<sup>st</sup> April 2004 to 15<sup>th</sup> May 2004)

# Latest date for which settlement data is available

Where forecasting before the relevant Financial Year concerned, The Company would in the above example use values for E and P from Financial Year 2003/04 and D from Financial Year 2004/05.

**iii) Half-Hourly (HH) Metered Demand Forecast – New User**

F = M \* T/W

where:

F = Forecast of User's HH metered demand at Triad for the Financial Year

M = User's HH average weekday period 35 demand for the last complete month for which settlement data is available

T = Total system HH demand at Triad in the preceding Financial Year

W = Total system HH average weekday settlement period 35 metered demand for the corresponding period to M for the preceding year

**Example:**

The Company calculates a HH demand forecast on the above methodology at 10<sup>th</sup> September 2005 for a new User registered from 10<sup>th</sup> June 2005 for the period 10<sup>th</sup> June 2004 to 31<sup>st</sup> March 2006.

F = 1,000 \* 17,000,000 / 18,888,888

F = 900 kWh

where:

M = 1,000 kWh (period 1<sup>st</sup> July 2005 to 31<sup>st</sup> July 2005)

T = 17,000,000 kWh (period November 2004 to February 2005)

W = 18,888,888 kWh (period 1<sup>st</sup> July 2004 to 31<sup>st</sup> July 2004)

**iv) Non Half Hourly (NHH) Metered Energy Consumption Forecast – New User**

F = J + (M \* R/W)

where:

- F = Forecast of User's NHH metered energy consumption for the Financial Year
- J = Residual part month summed NHH metered energy consumption for the hours 16:00 to 19:00 for each day where new User registration takes place other than on the first of a month
- M = User's summed NHH metered energy consumption for the hours 16:00 to 19:00 for each day for the last complete month for which settlement data is available
- R = Total system summed NHH metered energy consumption for the hours 16:00 to 19:00 for each day for the period from the start of that defined under M but for the preceding year and until the end of that preceding Financial Year
- W = Total system summed NHH metered energy consumption for the hours 16:00 to 19:00 for each day for the period identified in M but for the preceding Financial Year

**Example:**

The Company calculates a NHH energy consumption forecast on the above methodology at 10<sup>th</sup> September 2005 for a new User registered from 10<sup>th</sup> June 2005 for the period 10<sup>th</sup> June 2005 to 31<sup>st</sup> March 2006.

$$F = 500 + (1,000 * 20,000,000,000 / 2,000,000,000)$$

$$F = 10,500 \text{ kWh}$$

where:

$$J = 500 \text{ kWh (period 10}^{\text{th}} \text{ June 2005 to 30}^{\text{th}} \text{ June 2005)}$$

$$M = 1,000 \text{ kWh (period 1}^{\text{st}} \text{ July 2005 to 31}^{\text{st}} \text{ July 2005)}$$

$$R = 20,000,000,000 \text{ kWh (period 1}^{\text{st}} \text{ July 2004 to 31}^{\text{st}} \text{ March 2005)}$$

$$W = 2,000,000,000 \text{ kWh (period 1}^{\text{st}} \text{ July 2004 to 31}^{\text{st}} \text{ July 2004)}$$

## 14.29 Stability & Predictability of TNUoS tariffs

Deleted: 8

### Stability of tariffs

The Transmission Network Use of System Charging Methodology has a number of elements to enhance the stability of the tariffs, which is an important aspect of facilitating competition in the generation and supply of electricity. This appendix seeks to highlight those elements.

Each node of the transmission network is assigned to a zone. The result of this is to dampen fluctuations that would otherwise be observed at a given node caused by changes in generation, demand, and network parameters. The criteria used to establish generation zones are part of the methodology and are described in Paragraph 14.15.33.

Deleted: 26

These zones are themselves fixed for the duration of the price control period. The methodology does, however, allow these to be revisited in exceptional circumstances to ensure that the charges remain reasonably cost reflective or to accommodate changes to the network. In rare circumstances where such a re-zoning exercise is required, this will be undertaken in such a way that minimises the adverse impact on Users. This is described in Paragraph 14.15.36.

Deleted: 29

In addition to fixing zones, other key parameters within the methodology are also fixed for the duration of the price control period or annual changes restricted in some way. Specifically:

- the expansion constant, which reflects the annuitised value of capital investment required to transport 1MW over 1km by a 400kV over-head line, changes annually according to RPI. The other elements used to derive the expansion constant are only reviewed at the beginning of a price control period to ensure that it remains cost-reflective. This review will consider those components outlined in Paragraph 14.15.50 to Paragraph 14.15.60.
- the expansion factors, which are set on the same basis of the expansion constant and used to reflect the relative investment costs in each TO region of circuits at different transmission voltages and types, are fixed for the duration price control. These factors are reviewed at the beginning of a price control period and will take account of the same factors considered in the review of the expansion constant.
- the locational security factor, which reflects the transmission security provided under the NETS Security and Quality of Supply Standard, is fixed for the duration of the price control period and reviewed at the beginning of a price control period.

Deleted: 31

Deleted: 41

### Predictability of tariffs

The Company revises TNUoS tariffs each year to ensure that these remain cost-reflective and take into account changes to allowable income under the price control and RPI. There are a number of provisions within The Company's Transmission Licence and the CUSC designed to promote the predictability of annually varying charges. Specifically, The Company is required to give the Authority 150 days notice of its intention to change use of system charges together with a reasonable assessment of the proposals on those charges; and to give Users 2 months written notice of any revised charges. The Company typically provides an additional months notice of revised charges through the publication of "indicative" tariffs. Shorter notice periods are permitted by the framework but only following consent from the Authority.

These features require formal proposals to change the Transmission Use of System Charging Methodology to be initiated in October to provide sufficient time for a formal consultation and the Authority's veto period before charges are indicated to Users.

More fundamentally, The Company also provides Users with the tool used by The Company to calculate tariffs. This allows Users to make their own predictions on how future changes in the generation and supply sectors will influence tariffs. Along with the price control information, the data from the Seven Year Statement, and Users own prediction of market activity, Users are able to make a reasonable estimate of future tariffs and perform sensitivity analysis.

To supplement this, The Company also prepares an annual information paper that provides an indication of the future path of the locational element of tariffs over the next five years.<sup>4</sup> This analysis is based on data included within the Seven Year Statement. This report typically includes:

- an explanation of the events that have caused tariffs to change;
- sensitivity analysis to indicate how generation and demand tariffs would change as a result of changes in generation and demand at certain points on the network that are not included within the SYS;
- an assessment of the compliance with the zoning criteria throughout the five year period to indicate how generation zones might need to change in the future, with a view to minimising such changes and giving as much notice of the need, or potential need, to change generation zones; and
- a complete dataset for the DCLF Transport Model developed for each future year, to allow Users to undertake their own sensitivity analysis for specific scenarios that they may wish to model.

The first year of tariffs forecasted in the annual information paper are updated twice throughout the proceeding financial year as the various Transport and Tariff model inputs are received or amended. These updates are in addition to the Authority 150 days notice and publication of “indicative” tariffs.

| In addition, The Company will, when revising generation charging zones prior to a new price control period, undertake a zoning consultation that uses data from the latest information paper. The purpose of this consultation will be to ensure tariff zones are robust to contracted changes in generation and supply, which could be expected to reduce the need for re-zoning exercises within a price control period.

**Formatted:** Justified

**Deleted:** ¶  
¶  
¶  
-----Page Break-----  
¶

<sup>4</sup> <http://www.nationalgrid.com/uk/Electricity/Charges/gbchargingapprovalconditions/5/>





## CUSC - SECTION 14

### CHARGING METHODOLOGIES

#### CONTENTS

Part 2 -The Statement of the Use of System Charging Methodology

Formatted: Font: Bold

Formatted: Centered

Deleted: ¶

Section 1 – The Statement of the Transmission Use of System Charging Methodology;

14.14 Principles

14.15 Derivation of Transmission Network Use of System Tariff

14.16 Derivation of the Transmission Network Use of System Energy Consumption Tariff and Short Term Capacity Tariffs

14.17 Demand Charges

14.18 Generation Charges

14.19 Data Requirements

14.20 Applications

14.21 Transport Model Example

[14.22 Illustrative Calculation of Boundary Sharing Factors \(BSFs\) and Shared / Not-Shared incremental km](#)

Deleted: 2

[14.23 Example: Calculation of Zonal Generation Tariffs and Charges](#)

Deleted: ¶

[14.24 Example: Calculation of Zonal Demand Tariff](#)

Deleted: 3

[14.25 Reconciliation of Demand Related Transmission Network Use of System Charges](#)

Deleted: 4

[14.26 Classification of parties for charging purposes](#)

Deleted: 5

[14.27 Transmission Network Use of System Charging Flowcharts](#)

Deleted: 6

[14.28 Example: Determination of The Company's Forecast for Demand Charge Purposes](#)

Deleted: 7

[14.29 Stability & Predictability of TNUoS tariffs](#)

Deleted: 8

Section 2 – The Statement of the Balancing Services Use of System Charging Methodology

14.30 Principles

Deleted: 29

14.31 Calculation of the Daily Balancing Services Use of System charge

Deleted: 0

14.32 Settlement of BSUoS

Deleted: 1

14.33 Examples of Balancing Services Use of System (BSUoS) Daily Charge Calculations

Deleted: 2

## CUSC - SECTION 14

### CHARGING METHODOLOGIES

14.1 Introduction

14.1.1 This section of the CUSC sets out the statement of the Connection Charging Methodology and the Statement of the Use of System Methodology

Formatted: Tabs: 2.77 cm,  
List tab + Not at 1.5 cm

Formatted: Tabs: 3.63 cm,  
List tab + Not at 3 cm

Formatted: 1,2,3, Justified,  
Indent: Left: 0 cm

## Part 2 - The Statement of the Use of System Charging Methodology

Deleted:  
Formatted: Font: Arial (W1)  
Deleted: ¶

### Section 1 – The Statement of the Transmission Use of System Charging Methodology

#### 14.14 Principles

14.14.1 Transmission Network Use of System charges reflect the cost of installing, operating and maintaining the transmission system for the Transmission Owner (TO) Activity function of the Transmission Businesses of each Transmission Licensee. These activities are undertaken to the standards prescribed by the Transmission Licences, to provide the capability to allow the flow of bulk transfers of power between connection sites and to provide transmission system security.

Formatted: Font: Arial  
Formatted: Indent: Left: 1.27 cm, Numbered + Level: 1 + Numbering Style: 1, 2, 3, ... + Start at: 1 + Alignment: Left + Aligned at: 0 cm + Tab after: 0 cm + Indent at: 1.6 cm, Tabs: 1.9 cm, List tab + Not at 0 cm + 1.27 cm  
Formatted: Font: Arial  
Formatted: Font: Arial  
Formatted: Font: 11 pt

14.14.2 A Maximum Allowed Revenue (MAR) defined for these activities and those associated with pre-vesting connections is set by the Authority at the time of the Transmission Owners' price control review for the succeeding price control period. Transmission Network Use of System Charges are set to recover the Maximum Allowed Revenue as set by the Price Control (where necessary, allowing for any K<sub>i</sub> adjustment for under or over recovery in a previous year net of the income recovered through pre-vesting connection charges).

Formatted: Font: Arial  
Formatted: Indent: Left: 1.27 cm, Numbered + Level: 1 + Numbering Style: 1, 2, 3, ... + Start at: 1 + Alignment: Left + Aligned at: 0 cm + Tab after: 0 cm + Indent at: 1.6 cm, Tabs: 1.9 cm, List tab + Not at 0 cm + 1.27 cm

14.14.3 The basis of charging to recover the allowed revenue is the Investment Cost Related Pricing (ICRP) methodology, which was initially introduced by The Company in 1993/94 for England and Wales. The principles and methods underlying the ICRP methodology were set out in the The Company document "Transmission Use of System Charges Review: Proposed Investment Cost Related Pricing for Use of System (30 June 1992)".

Formatted: Font: Arial  
Formatted: Font: Arial  
Formatted: Font: Arial  
Formatted: Font: Arial

14.14.4 In December 2003, The Company published the Initial Thoughts consultation for a GB methodology using the England and Wales methodology as the basis for consultation. The Initial Methodologies consultation published by The Company in May 2004 proposed two options for a GB charging methodology with a Final Methodologies consultation published in August 2004 detailing The Company's response to the Industry with a recommendation for the GB charging methodology. In December 2004, The Company published a Revised Proposals consultation in response to the Authority's invitation for further review on certain areas in The Company's recommended GB charging methodology.

Formatted: Indent: Left: 1.27 cm, Numbered + Level: 1 + Numbering Style: 1, 2, 3, ... + Start at: 1 + Alignment: Left + Aligned at: 0 cm + Tab after: 0 cm + Indent at: 1.6 cm, Tabs: 1.9 cm, List tab + Not at 0 cm + 1.27 cm  
Formatted: Font: Arial  
Formatted: Font: Arial  
Formatted: Font: Arial

14.14.5 In April 2004 The Company introduced a DC Loadflow (DCLF) ICRP based transport model for the England and Wales charging methodology. The DCLF model has been extended to incorporate Scottish network data with existing England and Wales network data to form the GB network in the model. In April 2005, the GB charging methodology implemented the following proposals:

Formatted: Indent: Left: 1.27 cm, Numbered + Level: 1 + Numbering Style: 1, 2, 3, ... + Start at: 1 + Alignment: Left + Aligned at: 0 cm + Tab after: 0 cm + Indent at: 1.6 cm, Tabs: 1.9 cm, List tab + Not at 0 cm + 1.27 cm

i.) The application of multi-voltage circuit expansion factors with a forward-looking Expansion Constant that does not include substation costs in its derivation.

Formatted: Font: Arial  
Formatted: Font: Arial  
Formatted: ... [1]  
Formatted: Font: Arial  
Formatted: Font: Arial  
Formatted: ... [2]  
Formatted: Font: Arial

- ii.) The application of locational security costs, by applying a multiplier to the Expansion Constant reflecting the difference in cost incurred on a secure network as opposed to an unsecured network.
- iii.) The application of a de-minimus level demand charge of £0/kW for Half Hourly and £0/kWh for Non Half Hourly metered demand to avoid the introduction of negative demand tariffs.
- iv.) The application of 132kV expansion factor on a Transmission Owner basis reflecting the regional variations in network upgrade plans.
- v.) The application of a Transmission Network Use of System Revenue split between generation and demand of 27% and 73% respectively.
- vi.) The number of generation zones using the criteria outlined in paragraph 14.15.33 has been determined as 21.
- vii.) The number of demand zones has been determined as 14, corresponding to the 14 GSP groups.

14.14.6 The underlying rationale behind Transmission Network Use of System charges is that efficient economic signals are provided to Users when services are priced to reflect the incremental costs of supplying them. Therefore, charges should reflect the impact that Users of the transmission system at different locations would have on the Transmission Owner's costs, if they were to increase or decrease their use of the respective systems. These costs are primarily defined as the investment costs in the transmission system, maintenance of the transmission system and maintaining a system capable of providing a secure bulk supply of energy.

The Transmission Licence requires The Company to operate the National Electricity Transmission System to specified standards. In addition The Company with other transmission licensees are required to plan and develop the National Electricity Transmission System to meet these standards. These requirements mean that the system must conform to a particular Security Standard and capital investment requirements are largely driven by the need to conform to both the deterministic and supporting cost benefit analysis aspects of this standard. It is this obligation, which provides the underlying rationale for the ICRP approach, i.e. for any changes in generation and demand on the system, The Company must ensure that it satisfies the requirements of the Security Standard.

14.14.7 The Security Standard identifies requirements on the capacity of component sections of the system given the expected generation and demand at each node, such that demand can be met and generators' output over the course of a year (capped at their Transmission Entry Capacity, TEC) can be accommodated in the most economic and efficient manner. The derivation of the incremental investment costs at different points on the system is therefore determined against the requirements of the system both at the time of peak demand and across the remainder of the year. The Security Standard uses a Demand Security Criterion and an Economy Criterion to assess capacity requirements. The charging methodology therefore recognises both these elements in its rationale.

14.14.8 The Demand Security Criterion requires sufficient transmission system capacity such that peak demand can be met through generation sources as defined in the Security Standard, whilst the Economy Criterion requires sufficient transmission system capacity to accommodate all types of generation in order to meet varying levels of demand efficiently. The latter is achieved through a set of deterministic parameters that

Formatted: Font: Arial

Formatted: Indent: Left: 2.54 cm, Numbered + Level: 1 + Numbering Style: i, ii, iii, ... + Start at: 1 + Alignment: Left + Aligned at: 1.27 cm + Tab after: 2.54 cm + Indent at: 2.54 cm, Tabs: Not at 1.27 cm + 2.54 cm

Formatted: Font: Arial

Formatted: Font: Arial

Formatted: Indent: Left: 2.54 cm, Numbered + Level: 1 + Numbering Style: i, ii, iii, ... + Start at: 1 + Alignment: Left + Aligned at: 1.27 cm + Tab after: 2.54 cm + Indent at: 2.54 cm, Tabs: Not at 1.27 cm + 2.54 cm

Formatted: Font: Arial

Formatted: Font: Arial

Formatted: Indent: Left: 2.54 cm, Numbered + Level: 1 + Numbering Style: i, ii, iii, ... + Start at: 1 + Alignment: Left + Aligned at: 1.27 cm + Tab after: 2.54 cm + Indent at: 2.54 cm, Tabs: Not at 1.27 cm + 2.54 cm

Formatted: Font: Arial

Formatted: Font: Arial

Formatted: Indent: Left: 2.54 cm, Numbered + Level: 1 + Numbering Style: i, ii, iii, ... + Start at: 1 + Alignment: Left + Aligned at: 1.27 cm + Tab after: 2.54 cm + Indent at: 2.54 cm, Tabs: Not at 1.27 cm + 2.54 cm

Formatted: Font: Arial

Formatted: Font: Arial

Formatted: ... [3]

Deleted: 26

Formatted: Font: Arial, 11 pt

Formatted: Font: Arial

Formatted: Font: Arial, 11 pt

Formatted: ... [4]

Formatted: Font: Arial

Formatted: ... [5]

Formatted: ... [6]

Deleted: Capacities (TECs)

Deleted: .

Deleted: this peak element

Formatted: Indent: Left: 1.27 cm

Deleted: 14.14.8

Formatted: ... [7]

have been derived from a generic Cost Benefit Analysis (CBA) seeking to identify an appropriate balance between constraint costs and the costs of transmission reinforcements.

14.14.9 The TNUoS charging methodology seeks to reflect these arrangements through the use of dual backgrounds in the Transport Model, namely a Peak Security background representative of the Demand Security Criterion and a Year Round background representative of the Economy Criterion.

**Formatted:** Numbered + Level: 1 + Numbering Style: 1, 2, 3, ... + Start at: 5 + Alignment: Left + Aligned at: 1.27 cm + Tab after: 1.27 cm + Indent at: 2.87 cm, Tabs: 1.9 cm, List tab + Not at 1.27 cm

14.14.10 To recognise that various types of generation will have a different impact on incremental investment costs the charging methodology uses a generator's TEC, Peak Security flag, and Annual Load Factor (ALF) when determining Transmission Network Use of System charges relating to the Peak Security and Year Round backgrounds respectively. For the Year Round background the diversity of the plant mix (i.e the proportion of low carbon and carbon generation) in each charging zone is also taken into account.

**Formatted:** Numbered + Level: 1 + Numbering Style: 1, 2, 3, ... + Start at: 5 + Alignment: Left + Aligned at: 1.27 cm + Tab after: 1.27 cm + Indent at: 2.87 cm, Tabs: 1.9 cm, List tab + Not at 1.27 cm

14.14.11 In setting and reviewing these charges The Company has a number of further objectives. These are to:

**Formatted:** Font: 11 pt, Highlight

- \_\_\_\_\_ offer clarity of principles and transparency of the methodology;
- \_\_\_\_\_ inform existing Users and potential new entrants with accurate and stable cost messages;
- \_\_\_\_\_ charge on the basis of services provided and on the basis of incremental rather than average costs, and so promote the optimal use of and investment in the transmission system; and
- \_\_\_\_\_ be implementable within practical cost parameters and time-scales.

**Formatted:** Font: 11 pt, Highlight

**Formatted:** Font: 11 pt, Highlight

**Formatted:** Numbered + Level: 1 + Numbering Style: 1, 2, 3, ... + Start at: 5 + Alignment: Left + Aligned at: 1.27 cm + Tab after: 1.27 cm + Indent at: 2.87 cm, Tabs: 1.9 cm, List tab + Not at 1.27 cm

14.14.9 Condition C13 of The Company's Transmission Licence governs the adjustment to Use of System charges for small generators. Under the condition, The Company is required to reduce TNUoS charges paid by eligible small generators by a designated sum, which will be determined by the Authority. The licence condition describes an adjustment to generator charges for eligible plant, and a consequential change to demand charges to recover any shortfall in revenue. The mechanism for recovery will ensure revenue neutrality over the lifetime of its operation although it does allow for effective under or over recovery within any year. For the avoidance of doubt, Condition C13 does not form part of the Use of System Charging Methodology.

**Formatted:** Indent: Left: 2.5 cm, Hanging: 1.29 cm, Bulleted + Level: 1 + Aligned at: 0 cm + Tab after: 0.63 cm + Indent at: 0.63 cm, Tabs: 3.89 cm, List tab + Not at 0.63 cm + 1.27 cm

**Formatted:** Numbered + Level: 1 + Numbering Style: 1, 2, 3, ... + Start at: 9 + Alignment: Left + Aligned at: 1.27 cm + Tab after: 1.27 cm + Indent at: 2.87 cm, Tabs: 1.9 cm, List tab + Not at 1.27 cm

14.14.10 The Company will typically calculate TNUoS tariffs annually, publishing final tariffs in respect of a Financial Year by the end of the preceding January. However The Company may update the tariffs part way through a Financial Year.

**Formatted:** Numbered + Level: 1 + Numbering Style: 1, 2, 3, ... + Start at: 9 + Alignment: Left + Aligned at: 1.27 cm + Tab after: 1.27 cm + Indent at: 2.87 cm, Tabs: 1.9 cm, List tab + Not at 1.27 cm

## 14.15 Derivation of the Transmission Network Use of System Tariff

14.15.1 The Transmission Network Use of System (TNUoS) Tariff comprises two separate elements. Firstly, a locationally varying element derived from the DCLF ICRP transport model to reflect the costs of capital investment in, and the maintenance and operation of, a transmission system to provide bulk transport of power to and from different locations. Secondly, a non-locationally varying element related to the provision of residual revenue recovery. The combination of both these elements forms the TNUoS tariff.

14.15.2 For generation TNUoS tariffs the locational element itself is comprised of **five separate components**. **Three wider components** -

- o Wider Peak Security component
- o Wider Year Round Not-shared component
- o Wider Year Round Shared component

**These components reflect the costs of the wider network under the different generation backgrounds set out in the Demand Security Criterion (for Peak Security component) and Economy Criterion (for both Year Round components) of the Security Standard. The two Year Round components reflect the unshared and shared costs of the wider network based on the diversity of generation plant types.**

**Two local components -**

- o Local substation and
- o Local circuit

**These components reflect the costs of the local network.**

Accordingly, the wider tariff represents the combined effect of the **three wider** locational tariff components and the residual element; and the local tariff represents the combination of the two local locational tariff components.

14.15.3 The process for calculating the TNUoS tariff is described below.

### The Transport Model

#### Model Inputs

14.15.4 The DCLF ICRP transport model calculates the marginal costs of investment in the transmission system which would be required as a consequence of an increase in demand or generation at each connection point or node on the transmission system, based on a study of peak **demand conditions using both Peak Security and Year Round generation backgrounds** on the transmission system. One measure of the investment costs is in terms of MWkm. This is the concept that ICRP uses to calculate marginal costs of investment. Hence, marginal costs are estimated initially in terms of increases or decreases in units of kilometres (km) of the transmission system for a 1 MW injection to the system.

14.15.5 The transport model requires a set of inputs representative of **the Demand Security and Economy Criterion set out in the Security Standards. These** conditions on the transmission system **are represented in the Peak Security and Year Round background respectively as follows:**

**Formatted:** Numbered + Level: 1 + Numbering Style: 1, 2, 3, ... + Start at: 1 + Alignment: Left + Aligned at: 1.27 cm + Tab after: 1.27 cm + Indent at: 2.87 cm, Tabs: 1.9 cm, List tab + Not at: 1.27 cm

**Formatted:** Font: 11 pt, Highlight

**Formatted:** Numbered + Level: 1 + Numbering Style: 1, 2, 3, ... + Start at: 1 + Alignment: Left + Aligned at: 1.27 cm + Tab after: 1.27 cm + Indent at: 2.87 cm, Tabs: 1.9 cm, List tab + Not at: 1.27 cm

**Deleted:** three

**Deleted:** A

**Deleted:** component reflects

**Formatted:** Highlight

**Formatted:** Highlight

**Formatted:** Font: 11 pt, Highlight

**Formatted:** Bullets and Numbering

**Formatted:** Highlight

**Formatted:** Font: 11 pt, Highlight

**Formatted:** Highlight

**Formatted:** Font: 11 pt, Highlight

**Formatted:** Highlight

**Formatted:** ... [8]

**Deleted:** , and

**Deleted:** combination of a

**Formatted:** Highlight

**Formatted:** ... [9]

**Formatted:** Highlight

**Formatted:** ... [10]

**Deleted:** a local

**Formatted:** Highlight

**Formatted:** ... [11]

**Deleted:** component

**Formatted:** Highlight

**Formatted:** ... [12]

**Deleted:**

**Formatted:** Highlight

**Formatted:** ... [13]

**Formatted:** ... [14]

**Formatted:** ... [15]

**Formatted:** ... [16]

**Formatted:** ... [17]

**Deleted:** peak

- Nodal generation information per node (TEC, plant type and SOSS scaling factors)
- Nodal demand information
- Transmission circuits between these nodes
- The associated lengths of these routes, the proportion of which is overhead line or cable and the respective voltage level
- The cost ratio of each of 132kV overhead line, 132kV underground cable, 275kV overhead line, 275kV underground cable and 400kV underground cable to 400kV overhead line to give circuit expansion factors
- The cost ratio of each separate sub-sea AC circuit and HVDC circuit to 400kV overhead line to give circuit expansion factors
- 132kV overhead circuit capacity and single/double route construction information is used in the calculation of a generator's local charge.
- Offshore transmission cost and circuit/substation data

**Formatted:** Indent: Left: 3 cm, Hanging: 1 cm, Bulleted + Level: 1 + Aligned at: 0 cm + Tab after: 0.63 cm + Indent at: 0.63 cm, Tabs: 4.02 cm, List tab + Not at 0.63 cm + 1.27 cm

**Deleted:** costs

14.15.6 For a given charging year "t", the nodal generation TEC figure and generation plant types at each node will be based on the Applicable Value for year "t" in the NETS Seven Year Statement in year "t-1" plus updates to the October of year "t-1". The contracted TECs and generation plant types in the NETS Seven Year Statement include all plant belonging to generators who have a Bilateral Agreement with the TOs. For example, for 2010/11 charges, the nodal generation data is based on the forecast for 2010/11 in the 2009 NETS Seven Year Statement plus any data included in the quarterly updates in October 2009.

**Deleted:** Identification of a reference node

**Formatted:** Numbered + Level: 1 + Numbering Style: 1, 2, 3, ... + Start at: 1 + Alignment: Left + Aligned at: 1.27 cm + Tab after: 1.27 cm + Indent at: 2.87 cm, Tabs: 1.9 cm, List tab + Not at 1.27 cm

14.15.7 Scaling factors for different generation plant types are applied on their aggregated capacity for both Peak Security and Year Round backgrounds. The scaling is either Fixed or Variable (depending on the total demand level) in line with the factors used in the Security Standard, for example as shown in the table below.

**Formatted:** Numbered + Level: 1 + Numbering Style: 1, 2, 3, ... + Start at: 1 + Alignment: Left + Aligned at: 1.27 cm + Tab after: 1.27 cm + Indent at: 2.87 cm, Tabs: 1.9 cm, List tab + Not at 1.27 cm

<u>Generation Plant Type</u>	<u>Peak Security Background</u>	<u>Year Round Background</u>
<u>Intermittent</u>	<u>Fixed (0%)</u>	<u>Fixed (70%)</u>
<u>Nuclear &amp; CCS</u>	<u>Variable</u>	<u>Fixed (85%)</u>
<u>Interconnectors</u>	<u>Fixed (0%)</u>	<u>Fixed (100%)</u>
<u>Hydro</u>	<u>Variable</u>	<u>Variable</u>
<u>Pumped Storage</u>	<u>Variable</u>	<u>Fixed (50%)</u>
<u>Peaking</u>	<u>Variable</u>	<u>Fixed (0%)</u>
<u>Other (Conventional)</u>	<u>Variable</u>	<u>Variable</u>

These scaling factors and generation plant types are set out in the Security Standard. These may be reviewed from time to time. The latest version will be used in the calculation of TNUoS tariffs and is published in the Statement of Use of System Charges

**Formatted:** Indent: Left: 1.9 cm

**Formatted:** Numbered + Level: 1 + Numbering Style: 1, 2, 3, ... + Start at: 1 + Alignment: Left + Aligned at: 1.27 cm + Tab after: 1.27 cm + Indent at: 2.87 cm, Tabs: 1.9 cm, List tab + Not at 1.27 cm

14.15.8 National Grid will categorise plant based on the categorisations described in the Security Standard. Peaking plant will include oil and OCGT technologies and Other (Conv.) represents all remaining conventional plant not explicitly stated elsewhere in the tabl. In the event that a power station is made up of more than one technology type, the type of the higher Transmission Entry Capacity (TEC) would apply.

**Formatted:** Indent: Left: 1.27 cm, No bullets or numbering, Tabs: Not at 1.27

**Formatted:** Numbered + Level: 1 + Numbering Style: 1, 2, 3, ... + Start at: 1 + Alignment: Left + Aligned at: 1.27 cm + Tab after: 1.27 cm + Indent at: 2.87 cm, Tabs: 1.9 cm, List tab + Not at 1.27 cm

14.15.9 Nodal demand data for the transport model will be based upon the GSP demand that Users have forecast to occur at the time of National Grid Peak Average Cold Spell (ACS) Demand for year "t" in the April Seven Year Statement for year "t-1" plus updates to the October of year "t-1".

**Formatted:** Indent: Left: 0.63 cm



14.15.10 Transmission circuits for charging year "t" will be defined as those with existing wayleaves for the year "t" with the associated lengths based on the circuit lengths indicated for year "t" in the April NETS Seven Year Statement for year "t-1" plus updates to October of year "t-1". If certain circuit information is not explicitly contained in the NETS Seven Year Statement, The Company will use the best information available.

**Formatted:** Numbered + Level: 1 + Numbering Style: 1, 2, 3, ... + Start at: 1 + Alignment: Left + Aligned at: 1.27 cm + Tab after: 1.27 cm + Indent at: 2.87 cm, Tabs: 1.9 cm, List tab + Not at 1.27 cm

14.15.11 The circuit lengths included in the transport model are solely those, which relate to assets defined as 'Use of System' assets.

**Formatted:** Indent: Left: 0.63 cm

14.15.12 For HVDC circuits, the impedance will be calculated to provide flows based on a ratio of the capacity provided by the HVDC link relative to the capacities on all major transmission system boundaries that it parallels.

**Formatted:** Indent: Left: 1.9 cm, Numbered + Level: 1 + Numbering Style: 1, 2, 3, ... + Start at: 1 + Alignment: Left + Aligned at: 1.27 cm + Tab after: 1.27 cm + Indent at: 2.87 cm, Tabs: 1.9 cm, List tab + Not at 1.27 cm

14.15.13 The transport model employs the use of circuit expansion factors to reflect the difference in cost between (i) AC circuits and HVDC circuits, (ii) underground and sub-sea circuits, (iii) cabled circuits and overhead line circuits, (iv) 132kV and 275kV circuits, (v) 275kV circuits and 400kV circuits, and (vi), uses 400kV overhead line (i.e. the 400kV overhead line expansion factor is 1). As the transport model expresses cost as marginal km (irrespective of cables or overhead lines), some account needs to be made of the fact that investment in these other types of circuit (specifically HVDC and sub-sea cables of various voltages, 400kV underground cable, 275kV overhead line, 275kV underground cable, 132kV overhead line and 132kV underground cable) is more expensive than for 400kV overhead line. This is done by effectively 'expanding' these more expensive circuits by the relevant circuit expansion factor, thereby producing a larger marginal kilometre to reflect the additional cost of investing in these circuits compared to 400kV overhead line. When calculating the local circuit tariff for a generator, alternative 132kV and offshore expansion factors to those used in the remainder of the tariff calculation are applied to the generator's local circuits.

**Formatted:** Indent: Left: 0.63 cm

**Formatted:** Indent: Left: 1.9 cm, Numbered + Level: 1 + Numbering Style: 1, 2, 3, ... + Start at: 1 + Alignment: Left + Aligned at: 1.27 cm + Tab after: 1.27 cm + Indent at: 2.87 cm, Tabs: 1.9 cm, List tab + Not at 1.27 cm

14.15.14 The circuit expansion factors for HVDC circuits and AC subsea cables are determined on a case by case basis using the costs which are specific to the individual projects containing HVDC or AC subsea circuits.

**Formatted** ... [18]

**Deleted:** routes

**Deleted:** routes, (ii)

**Deleted:** routes, (iii)

**Deleted:** routes

**Deleted:** routes

**Deleted:** iv

**Formatted** ... [19]

**Model Outputs**

14.15.15 The transport model takes the inputs described above and carries out the following steps individually for Peak Security and Year Round backgrounds.

**Deleted:** A reference no ... [20]

**Formatted** ... [21]

**Deleted:** point for

**Deleted:** calculation of marginal

**Deleted:** . It determines ... [22]

**Deleted:** North of Scotl ... [23]

**Deleted:** ¶

14.15.16 Depending on the background, the TEC of the relevant generation plant types are scaled by a percentage as described in 14.15.7, above. The TEC of the remaining generation plant types in each background are uniformly scaled such that total national generation (scaled sum of contracted TECs) equals total national ACS Demand.

**Formatted** ... [24]

**Formatted** ... [25]

**Formatted** ... [26]

**Deleted:** firstly scales

**Deleted:** nodal

**Formatted** ... [27]

**Deleted:** capacity

**Deleted:** The

14.15.17 For each background, the model then uses a DCLF ICRP transport algorithm to derive the resultant pattern of flows based on the network impedance required to meet the nodal demand using the scaled nodal generation, assuming every circuit has infinite capacity. Flows on individual transmission circuits are compared for both backgrounds and the background giving rise to the highest flow is considered as the triggering criterion for future investment of that circuit for the purposes of the charging methodology. Therefore all circuits will be tagged as Peak Security or Year Round depending upon the background resulting in the highest flow. In the event that both backgrounds result in the same flow, the circuit will be tagged as Peak Security. Then it calculates the resultant total network Peak Security MWkm

**Formatted** ... [28]

**Deleted:** for

and Year Round MWkm, using the relevant circuit expansion factors as appropriate.

14.15.18 Using these baseline networks for Peak Security and Year Round backgrounds, the model then calculates for a given injection of 1MW of generation at each node, with a corresponding 1MW offtake (demand) distributed across all demand nodes in the network, the increase or decrease in total MWkm of the whole Peak Security and Year Round networks. The proportion of the 1MW offtake allocated to any given demand node will be based on total background nodal demand in the model. For example, with a total GB demand of 60GW in the model, a node with a demand of 600MW would contain 1% of the offtake i.e. 0.01MW.

14.15.19 Given the assumption of a 1MW injection, for simplicity the marginal costs are expressed solely in km. This gives a Peak Security marginal km cost and a Year Round marginal km cost for generation at each node (although not that used to calculate generation tariffs which considers local and wider cost components). The Peak Security and Year Round marginal km costs for demand at each node are equal and opposite to the Peak Security and Year Round nodal marginal km respectively for generation and these are used to calculate demand tariffs. Note the marginal km costs can be positive or negative depending on the impact the injection of 1MW of generation has on the total circuit km.

14.15.20 Using a similar methodology as described above in 14.15.18, the local and wider marginal km costs used to determine generation TNUoS tariffs are calculated by injecting 1MW of generation against the node(s) the generator is modelled at and increasing by 1MW the offtake across the distributed reference node. It should be noted that although the wider marginal km costs are calculated for both Peak Security and Year Round backgrounds, the local marginal km costs are calculated on the Year Round background.

14.15.21 In addition, any circuits in the model, identified as local assets to a node will have the local circuit expansion factors which are applied in calculating that particular node's marginal km. Any remaining circuits will have the TO specific wider circuit expansion factors applied.

14.15.22 An example is contained in 14.21 Transport Model Example.

### Calculation of local nodal marginal km

14.15.23 In order to ensure assets local to generation are charged in a cost reflective manner, a generation local circuit tariff is calculated. The nodal specific charge provides a financial signal reflecting the security and construction of the infrastructure circuits that connect the node to the transmission system.

14.15.24 Main Interconnected Transmission System (MITS) nodes are defined as:

- Grid Supply Point connections with 2 or more transmission circuits connecting at the site; or
- connections with more than 4 transmission circuits connecting at the site.

14.15.25 Where a Grid Supply Point is defined as a point of supply from the National Electricity Transmission System to network operators or non-embedded customers excluding generator or interconnector load alone. For the avoidance of doubt, generator or interconnector load would be subject to the circuit component of its Local Charge. A transmission circuit is part of the National Electricity Transmission System between

**Formatted:** Indent: Left: 0.63 cm

**Formatted:** Indent: Left: 1.9 cm, Numbered + Level: 1 + Numbering Style: 1, 2, 3, ... + Start at: 1 + Alignment: Left + Aligned at: 1.27 cm + Tab after: 1.27 cm + Indent at: 2.87 cm, Tabs: 1.9 cm, List tab + Not at 1.27 cm

**Deleted:** this

**Deleted:** at the reference node.

**Deleted:** network.

**Formatted:** Indent: Left: 1.9 cm, Numbered + Level: 1 + Numbering Style: 1, 2, 3, ... + Start at: 1 + Alignment: Left + Aligned at: 1.27 cm + Tab after: 1.27 cm + Indent at: 2.87 cm, Tabs: 1.9 cm, List tab + Not at 1.27 cm

**Deleted:** cost

**Deleted:** node

**Deleted:** this

**Deleted:** this is

**Formatted:** Indent: Left: 1.9 cm, No bullets or numbering, Tabs: Not at 1.27 cm

**Deleted:** <#>¶

**Formatted:** Indent: Left: 1.9 cm, Numbered + Level: 1 + Numbering Style: 1, 2, 3, ... + Start at: 1 + Alignment: Left + Aligned at: 1.27 cm + Tab after: 1.27 cm + Indent at: 2.87 cm, Tabs: 1.9 cm, List tab + Not at 1.27 cm

**Deleted:** at

**Deleted:**

**Formatted:** Indent: Left: 1.9 cm, Numbered + Level: 1 + Numbering Style: 1, 2, 3, ... + Start at: 1 + Alignment: Left + Aligned at: 1.27 cm + Tab after: 1.27 cm + Indent at: 2.87 cm, Tabs: 1.9 cm, List tab + Not at 1.27 cm

**Deleted:** this model,

**Formatted:** Indent: Left: 0.63 cm

**Formatted:** ... [29]

**Formatted:** Indent: Left: 0.63 cm

**Formatted:** ... [30]

**Formatted:** Justified, Indent: Left: 1.9 cm

**Formatted:** Bullets and Numbering

**Formatted:** ... [31]

**Formatted:** Bullets and Numbering

two or more circuit-breakers which includes transformers, cables and overhead lines but excludes busbars and generation circuits.

14.15.26 Generators directly connected to a MITS node will have a zero local circuit tariff.

14.15.27 Generators not connected to a MITS node will have a local circuit tariff derived from the local nodal marginal km for the generation node i.e. the increase or decrease in marginal km along the transmission circuits connecting it to all adjacent MITS nodes (local assets).

**Calculation of zonal marginal km**

14.15.28 Given the requirement for relatively stable cost messages through the ICRP methodology and administrative simplicity, nodes are assigned to zones. Typically, generation zones will be reviewed at the beginning of each price control period with another review only undertaken in exceptional circumstances. Any rezoning required during a price control period will be undertaken with the intention of minimal disruption to the established zonal boundaries. The full criteria for determining generation zones are outlined in paragraph 14.15.33. The number of generation zones set for 2010/11 is 20.

14.15.29 Demand zone boundaries have been fixed and relate to the GSP Groups used for energy market settlement purposes.

14.15.30 The nodal marginal km are amalgamated into zones by weighting them by their relevant generation or demand capacity.

14.15.31 Generators will have zonal tariffs derived from both, the wider Peak Security nodal marginal km; and the wider Year Round nodal marginal km for the generation node, calculated as the increase or decrease in marginal km along all transmission circuits except those classified as local assets.

The zonal Peak Security marginal km for generation is calculated as:

$$WNMkm_{j PS} = \frac{NMkm_{j PS} * Gen_j}{\sum_{j \in Gi} Gen_j}$$

$$ZMkm_{Gi PS} = \sum_{j \in Gi} WNMkm_{j PS}$$

Where

Gi = Generation zone

j = Node

NMkm<sub>ps</sub> = Peak Security Wider nodal marginal km from transport model

WNMkm<sub>ps</sub> = Peak Security Weighted nodal marginal km

ZMkm<sub>ps</sub> = Peak Security Zonal Marginal km

Gen = Nodal Generation (scaled by the appropriate Peak Security Scaling factor) from the transport model

Similarly, the zonal Year Round marginal km for generation is calculated as:

**Formatted:** Indent: Left: 1.9 cm, Numbered + Level: 1 + Numbering Style: 1, 2, 3, ... + Start at: 1 + Alignment: Left + Aligned at: 1.27 cm + Tab after: 1.27 cm + Indent at: 2.87 cm, Tabs: 1.9 cm, List tab + Not at 1.27 cm

**Formatted:** Indent: Left: 0.63 cm

**Formatted:** Indent: Left: 1.9 cm, Numbered + Level: 1 + Numbering Style: 1, 2, 3, ... + Start at: 1 + Alignment: Left + Aligned at: 1.27 cm + Tab after: 1.27 cm + Indent at: 2.87 cm, Tabs: 1.9 cm, List tab + Not at 1.27 cm

**Formatted:** Indent: Left: 0.63 cm

**Formatted:** Bullets and Numbering

**Deleted:** 26

**Formatted:** Bullets and Numbering

**Formatted:** Bullets and Numbering

**Formatted:** Bullets and Numbering

**Deleted:** a

**Deleted:** tariff

**Formatted:** Indent: Left: 1.27 cm, No bullets or numbering, Tabs: Not at 1.27

**Deleted:**  $WNMkm_j = \frac{NMkm_j}{\sum_{j \in Gi} Gen_j}$

**Deleted:** ¶

**Deleted:**  $ZMkm_{Gi} = \sum_{j \in Gi} WNMkm_{j PS}$

**Deleted:** . . .

**Deleted:** . . .

**Deleted:** . . .

**Formatted:** Indent: Left: 1.27 cm, Hanging: 3.81 cm

**Deleted:** . . .

**Deleted:** The

**Deleted:** demand zones are

**Deleted:** follows:¶

$$WNMkm_{jYR} = \frac{NMkm_{jYR} * Gen_j}{\sum_{j \in Gi} Gen_j}$$

**Deleted:**  $WNMkm_j = \frac{-1 *}{\sum_{j \in Gi} Gen_j}$

$$ZMkm_{GiYR} = \sum_{j \in Gi} WNMkm_{jYR}$$

**Formatted:** Justified  
**Formatted:** Font: Arial (W1), 11 pt

**Deleted:**  $ZMkm_{Di} = \sum_{j \in Di} WNMkm_{jYR}$

**Formatted:** Justified  
**Formatted:** Indent: Left: 1.27 cm, First line: 0 cm

Where

$NMkm_{YR}$  = Year Round Wider nodal marginal km from transport model

$WNMkm_{YR}$  = Year Round Weighted nodal marginal km

$ZMkm_{YR}$  = Year Round Zonal Marginal km

Gen = Nodal Generation (scaled by the appropriate Year Round Scaling factor) from the transport model

14.15.32 The zonal Peak Security marginal km for demand zones are calculated as follows:

**Formatted:** Bullets and Numbering

$$WNMkm_{jPS} = \frac{-1 * NMkm_{jPS} * Dem_j}{\sum_{j \in Di} Dem_j}$$

$$ZMkm_{DiPS} = \sum_{j \in Di} WNMkm_{jPS}$$

Where:

Di = Demand zone

Dem = Nodal Demand from transport model

Similarly, the zonal Year Round marginal km for demand zones are calculated as follows:

**Formatted:** Indent: Left: 1.6 cm

$$WNMkm_{jYR} = \frac{-1 * NMkm_{jYR} * Dem_j}{\sum_{j \in Di} Dem_j}$$

$$ZMkm_{DiYR} = \sum_{j \in Di} WNMkm_{jYR}$$

14.15.33 A number of criteria are used to determine the definition of the generation zones.

**Formatted:** Bullets and Numbering

Whilst it is the intention of The Company that zones are fixed for the duration of a price control period, it may become necessary in exceptional circumstances to review the boundaries having been set. In both circumstances, the following criteria are used to determine the zonal boundaries:

- i.) Zoning is determined using the generation background with the most MWkm of circuits. Zones should contain relevant nodes whose total wider marginal costs from the relevant generation background (as determined from the output from the transport model, the relevant expansion constant and the locational security factor,

**Formatted:** Indent: Left: 2.75 cm, Numbered + Level: 1 + Numbering Style: i, ii, iii, ... + Start at: 1 + Alignment: Left + Aligned at: 0 cm + Tab after: 1.27 cm + Indent at: 0 cm, Tabs: 3.6 cm, List tab + Not at 1.27 cm

see below) are all within +/-£1.00/kW (nominal prices) across the zone. This means a maximum spread of £2.00/kW in nominal prices across the zone.

ii.) The nodes within zones should be geographically and electrically proximate.

iii.) Relevant nodes are considered to be those with generation connected to them as these are the only ones, which contribute to the calculation of the zonal generation tariff.

**14.15.34** The process behind the criteria in 14.15.33 is driven by initially applying the nodal marginal costs from the relevant generation background within the DCLF Transport model onto the appropriate areas of a substation line diagram. Generation nodes are grouped into initial zones using the +/- £1.00/kW range. All nodes within each zone are then checked to ensure the geographically and electrically proximate criteria have been met using the substation line diagram. The established zones are inspected to ensure the least number of zones are used with minimal change from previously established zonal boundaries. The zonal boundaries are finally confirmed using the demand nodal costs from the relevant generation background for guidance.

**14.15.35** The zoning criteria are applied to a reasonable range of DCLF ICRP transport model scenarios, the inputs to which are determined by The Company to create appropriate TNUoS generation zones. The minimum number of zones, which meet the stated criteria, are used. If there is more than one feasible zonal definition of a certain number of zones, The Company determines and uses the one that best reflects the physical system boundaries.

**14.15.36** Zones will typically not be reviewed more frequently than once every price control period to provide some stability. However, in exceptional circumstances, it may be necessary to review zoning more frequently to maintain appropriate, cost reflective, locational cost signals. For example, if a new generator connecting to the transmission system would cause the creation of a new generation zone for that generator alone, it may not be appropriate from a cost reflective perspective to wait until the next price control period to undertake this rezoning. If any such rezoning is required, it will be undertaken against a background of minimal change to existing generation zones and in line with the notification process set out in the Transmission Licence and CUSC.

**Accounting for Sharing of Transmission by Generators**

**14.15.37** A proportion of the marginal km costs for generation are shared incremental km reflecting the ability of differing generation technologies to share transmission investment. This is reflected in charges through the splitting of Year Round marginal km costs for generation into Year Round Shared marginal km costs and Year Round Not-Shared marginal km which are then used in the calculation of the wider £/kW generation tariff.

**14.15.38** The sharing between different generation types is accounted for by (a) using transmission network boundaries between generation charging zones set by connectivity between generation charging zones, and (b) the proportion of Low Carbon and Carbon generation behind these boundaries.

**14.15.39** The zonal incremental km for each generation charging zone is split into each boundary component by considering the difference between it and the neighbouring generation charging zone using the formula below:

$$Bk_{ab} = Zk_{ab} - Zk_{ba}$$

Where:

**Formatted:** Indent: Left: 2.75 cm

**Formatted:** Indent: Left: 2.75 cm, Numbered + Level: 1 + Numbering Style: i, ii, iii, ... + Start at: 1 + Alignment: Left + Aligned at: 0 cm + Tab after: 1.27 cm + Indent at: 0 cm, Tabs: 3.6 cm, List tab + Not at 1.27 cm

**Formatted:** Indent: Left: 2.75 cm

**Formatted:** Indent: Left: 2.75 cm, Numbered + Level: 1 + Numbering Style: i, ii, iii, ... + Start at: 1 + Alignment: Left + Aligned at: 0 cm + Tab after: 1.27 cm + Indent at: 0 cm, Tabs: 3.6 cm, List tab + Not at 1.27 cm

**Formatted:** Bullets and Numbering

**Deleted:** 26

**Formatted:** Bullets and Numbering

**Formatted:** Bullets and Numbering

**Formatted:** Font: 11 pt, Highlight

**Formatted:** Indent: Left: 1.9 cm, Numbered + Level: 1 + Numbering Style: 1, 2, 3, ... + Start at: 1 + Alignment: Left + Aligned at: 1.27 cm + Tab after: 1.27 cm + Indent at: 2.87 cm, Tabs: 1.9 cm, List tab + Not at 1.27 cm

**Formatted:** Indent: Left: 1.9 cm

**Formatted:** Indent: Left: 1.9 cm, Numbered + Level: 1 + Numbering Style: 1, 2, 3, ... + Start at: 1 + Alignment: Left + Aligned at: 1.27 cm + Tab after: 1.27 cm + Indent at: 2.87 cm, Tabs: 1.9 cm, List tab + Not at 1.27 cm

**Formatted:** Indent: Left: 1.9 cm, Hanging: 1.69 cm, Numbered + Level: 1 + Numbering Style: 1, 2, 3, ... + Start at: 1 + Alignment: Left + Aligned at: 1.27 cm + Tab after: 1.27 cm + Indent at: 2.87 cm, Tabs: 1.69 cm, List tab + Not at 1.27 cm

$BI_{km_{ab}}$  = boundary incremental km between generation charging zone A and generation charging zone B  
 $ZI_{km}$  = generation charging zone incremental km

14.15.40 The table below shows the categorisation of Low Carbon and Carbon generation. This table will be updated by National Grid in the Statement of Use of System Charges as new generation technologies are developed.

Carbon	Low Carbon
Coal	Wind
Gas	Hydro (excl. Pumped Storage)
Biomass	Nuclear
Oil	Marine
Pumped Storage	Tidal
Interconnectors	

**Formatted:** Indent: Left: 1.9 cm, Hanging: 1.69 cm, Numbered + Level: 1 + Numbering Style: 1, 2, 3, ... + Start at: 1 + Alignment: Left + Aligned at: 1.27 cm + Tab after: 1.27 cm + Indent at: 2.87 cm

Determination of Connectivity

14.15.41 Connectivity is based on the existence of electrical circuits between TNUoS generation charging zones that are represented in the Transport model. Where such paths exist, generation charging zones will be effectively linked via an incremental km transmission boundary length. These paths will be simplified through in the case of:

**Formatted:** Indent: Left: 1.9 cm, Numbered + Level: 1 + Numbering Style: 1, 2, 3, ... + Start at: 1 + Alignment: Left + Aligned at: 1.27 cm + Tab after: 1.27 cm + Indent at: 2.87 cm, Tabs: 1.69 cm, List tab + Not at 1.27 cm

- Parallel paths – the longest path will be taken. An illustrative example is shown below with x, y and z representing the incremental km between zones.

**Formatted:** Indent: Left: 1.9 cm, Bulleted + Level: 1 + Aligned at: 0 cm + Tab after: 0.63 cm + Indent at: 0.63 cm, Tabs: 2.54 cm, List tab + Not at 0.63 cm + 1.27 cm

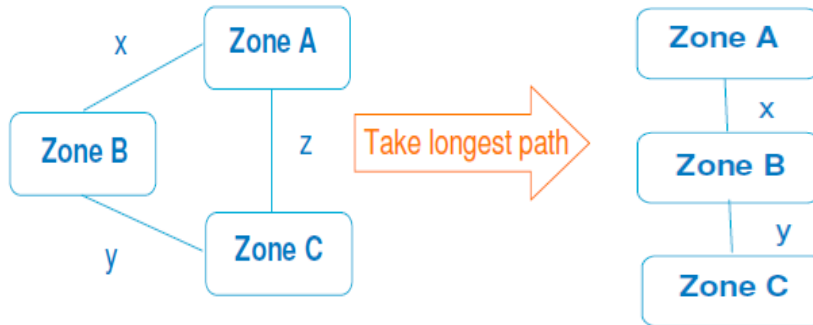

- Parallel zones – parallel zones will be amalgamated with the incremental km immediately beyond the amalgamated zones being the greater of those existing prior to the amalgamation. An illustrative example is shown below with a, b, c, and d representing the the initial incremental km between zones, and x and y representing the final incremental km following zonal amalgamation.

**Formatted:** Indent: Left: 1.9 cm, Bulleted + Level: 1 + Aligned at: 0 cm + Tab after: 0.63 cm + Indent at: 0.63 cm, Tabs: 2.54 cm, List tab + Not at 0.63 cm + 1.27 cm

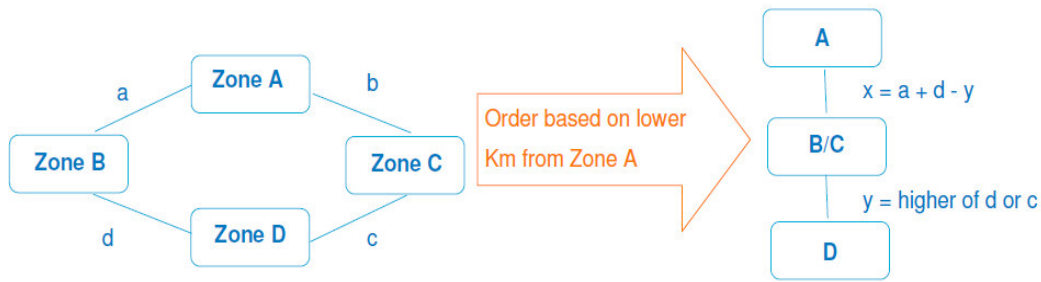

14.15.42 An illustrative Connectivity diagram is shown below:



Formatted: Indent: Left: 1.9 cm, Numbered + Level: 1 + Numbering Style: 1, 2, 3, ... + Start at: 1 + Alignment: Left + Aligned at: 1.27 cm + Tab after: 1.27 cm + Indent at: 2.87 cm, Tabs: 1.69 cm, List tab + Not at 1.27 cm

The arrows connecting generation charging zones and amalgamated generation charging zones represent the incremental km transmission boundary lengths towards the notional centre of the system. Generation located in zones behind arrows is considered to share based on the ratio of Low Carbon to Carbon cumulative generation TEC within those zones.

14.15.43 The Company will review Connectivity at the beginning of a new price control period, and under exceptional circumstances such as major system reconfigurations or generation rezoning. If any such reassessment is required, it will be undertaken against a background of minimal change to existing Connectivity and in line with the notification process set out in the Transmission Licence and the CUSC.

Formatted: Bullets and Numbering

Calculation of Boundary Sharing Factors

14.15.44 Boundary sharing factors are derived from the comparison of the cumulative proportion of Low Carbon and Carbon generation TEC behind each of the incremental MWkm boundary lengths using the following formula –

Formatted: Bullets and Numbering

$$BSF = \text{Minimum} \left( \frac{LC}{LC+C}, \frac{C}{LC+C} \right)$$

Field Code Changed

Where:

BSF = Boundary Sharing Factor

LC = Cumulative Low carbon generation TEC behind the relevant transmission boundary

C = Cumulative Carbon generation TEC behind the relevant transmission boundary

14.15.45 The shared incremental km for each boundary are derived from the multiplication of the boundary sharing factor by the incremental km for that boundary:

Formatted: Bullets and Numbering

$$SBIkm_{ab} = BIIkm_{ab} \times BSF_{ab}$$

Where:

SBIkm<sub>ab</sub> = shared boundary incremental km between generation charging zone A and generation charging zone B

BSF<sub>ab</sub> = generation charging zone boundary sharing factor

14.15.46 The shared incremental km is discounted from the incremental km for that boundary to establish the not-shared boundary incremental km. The not-shared boundary incremental km reflects the cost of transmission investment on that boundary accounting for the sharing of power stations behind that boundary.

Formatted: Bullets and Numbering

$$NSBIkm_{ab} = BIIkm_{ab} - SBIkm_{ab}$$

Where:

NSBIkm<sub>ab</sub> = not shared boundary incremental km between generation charging zone A and generation charging zone B

14.15.47 The shared incremental km for a generation charging zone is the sum of the appropriate shared boundary incremental km for that generation charging zone as derived from the connectivity diagram.

Formatted: Bullets and Numbering

$$\sum_a^n NSBIkm_{ab} = ZMkm_{nYRS}$$

Field Code Changed

Where:

ZMkm<sub>nYRS</sub> = Year Round Shared Zonal Marginal km for generation charging zone n

Formatted: Highlight

14.15.48 The not-shared incremental km for a generation zone is the sum of the appropriate not-shared boundary incremental km for that generation zone as derived from the connectivity diagram.

Formatted: Indent: Left: 1.27 cm

Formatted: Bullets and Numbering

$$\sum_a^n NSBIkm_{ab} = ZMkm_{nYRNS}$$

Where:

ZMkm<sub>nYRNS</sub> = Year Round Not-Shared Zonal Marginal km for generation charging zone n

Formatted: Indent: Left: 3.6 cm, Tabs: Not at 2 cm + 2.5 cm + 3 cm

## Deriving the Final Local £/kW Tariff and the Wider £/kW Tariff



**14.15.49** The zonal marginal km ( $ZM_{km_{Gi}}$ ) are converted into costs and hence a tariff by multiplying by the **Expansion Constant** and the **Locational Security Factor** (see below). The nodal local marginal km ( $NLM_{km^L}$ ) are converted into costs and hence a tariff by multiplying by the **Expansion Constant** and a **Local Security Factor**.

Formatted: Bullets and Numbering

**The Expansion Constant**

**14.15.50** The expansion constant, expressed in £/MWkm, represents the annuitised value of the transmission infrastructure capital investment required to transport 1 MW over 1 km. Its magnitude is derived from the projected cost of 400kV overhead line, including an estimate of the cost of capital, to provide for future system expansion.

Formatted: Bullets and Numbering

**14.15.51** In the methodology, the expansion constant is used to convert the marginal km figure derived from the transport model into a £/MW signal. The tariff model performs this calculation, in accordance with 14.15.82 – 14.15.104, and also then calculates the residual element of the overall tariff (to ensure correct revenue recovery in accordance with the price control), in accordance with 14.15.120.

Formatted: Bullets and Numbering

Deleted: 60...65...81 ... [32]

**14.15.52** The transmission infrastructure capital costs used in the calculation of the expansion constant are provided via an externally audited process. They also include information provided from all onshore Transmission Owners (TOs). They are based on historic costs and tender valuations adjusted by a number of indices (e.g. global price of steel, labour, inflation, etc.). The objective of these adjustments is to make the costs reflect current prices, making the tariffs as forward looking as possible. This cost data represents The Company’s best view; however it is considered as commercially sensitive and is therefore treated as confidential. The calculation of the expansion constant also relies on a significant amount of transmission asset information, much of which is provided in the Seven Year Statement.

Formatted: Bullets and Numbering

**14.15.53** For each circuit type and voltage used onshore, an individual calculation is carried out to establish a £/MWkm figure, normalised against the 400KV overhead line (OHL) figure, these provide the basis of the onshore circuit expansion factors discussed in 14.15.61 – 14.15.68. In order to simplify the calculation a unity power factor is assumed, converting £/MVakm to £/MWkm. This reflects that the fact tariffs and charges are based on real power.

Formatted: Bullets and Numbering

Deleted: 42...47 ... [33]

**14.15.54** The table below shows the first stage in calculating the onshore expansion constant. A range of overhead line types is used and the types are weighted by recent usage on the transmission system. This is a simplified calculation for 400kV OHL using example data:

Formatted: Bullets and Numbering

Formatted: Font: 11 pt

Formatted ... [34]

Formatted ... [35]

Formatted ... [36]

Formatted ... [37]

Formatted ... [38]

Formatted ... [39]

Formatted ... [40]

Formatted ... [41]

Formatted ... [42]

Formatted: Font: 11 pt

Formatted: Font: 11 pt

Formatted: Font: 11 pt

Formatted: Font: 11 pt

Formatted: Font: 11 pt

Formatted: Font: 11 pt

400kV OHL expansion constant calculation					
MW	Type	£(000)/km	Circuit km*	£/MWkm	Weight
A	B	C	D	E = C/A	F=E*D
6500	La	700	500	107.69	53846
6500	Lb	780	0	120.00	0
3500	La/b	600	200	171.43	34286
3600	Lc	400	300	111.11	33333
4000	Lc/a	450	1100	112.50	123750
5000	Ld	500	300	100.00	30000
5400	Ld/a	550	100	101.85	10185
<b>Sum</b>			<b>2500 (G)</b>		<b>285400 (H)</b>

<b>Weighted Average (J= H/G):</b>	<b>114.160 (J)</b>
---	--------------------

\*These are circuit km of types that have been provided in the previous 10 years. If no information is available for a particular category the best forecast will be used.

Formatted: Font: 11 pt

Formatted: Font: 11 pt

Formatted: Font: 11 pt

Formatted: Font: 11 pt

Formatted: Font: 11 pt

Formatted: Font: 11 pt

Formatted: Font: 11 pt

Formatted: Bullets and Numbering

**14.15.55** The weighted average £/MWkm (J in the example above) is then converted in to an annual figure by multiplying it by an annuity factor. The formula used to calculate of the annuity factor is shown below:

$$Annuity\ factor = \frac{1}{\left[ \frac{1 - (1 + WACC)^{-Asset\ Life}}{WACC} \right]}$$

**14.15.56** The Weighted Average Cost of Capital (WACC) and asset life are established at the start of a price control and remain constant throughout a price control period. The WACC used in the calculation of the annuity factor is the The Company regulated rate of return, this assumes that it will be reasonably representative of all licensees. The asset life used in the calculation is 50 years; the appropriateness of this is reviewed when the annuity factor is recalculated at the start of a price control period. These assumptions provide a current annuity factor of 0.066.

Formatted: Bullets and Numbering

**14.15.57** The final step in calculating the expansion constant is to add a share of the annual transmission overheads (maintenance, rates etc). This is done by multiplying the average weighted cost (J) by an ‘overhead factor’. The ‘overhead factor’ represents the total business overhead in any year divided by the total Gross Asset Value (GAV) of the transmission system. This is recalculated at the start of each price control period. The overhead factor used in the calculation of the expansion constant for 2009/10 is 1.8%. The overhead and annuitised costs are then added to give the expansion constant.

Formatted: Bullets and Numbering

**14.15.58** Using the previous example, the final steps in establishing the expansion constant are demonstrated below:

Formatted: Bullets and Numbering

400kV OHL expansion constant calculation	Ave £/MWkm
OHL	114.160
Annuitised	7.535
Overhead	2.055
<b>Final</b>	<b>9.589</b>

**14.15.59** This process is carried out for each voltage onshore, along with other adjustments to take account of upgrade options, see 14.15.64, and normalised against the 400KV overhead line cost (the expansion constant) the resulting ratios provide the basis of the onshore expansion factors. The process used to derive circuit expansion factors for Offshore Transmission Owner networks is described in 14.15.69.

Formatted: Bullets and Numbering

Deleted: 45

Deleted: 50

**14.15.60** This process of calculating the incremental cost of capacity for a 400kV OHL, along with calculating the onshore expansion factors is carried out for the first year of the price control and is increased by inflation, RPI, (May–October average increase, as defined in The Company’s Transmission Licence) each subsequent year of the price control period. The expansion constant for 2010/11 is 10.633.

Formatted: Bullets and Numbering

**Onshore Wider Circuit Expansion Factors**

- 14.15.61** Base onshore expansion factors are calculated by deriving individual expansion constants for the various types of circuit, following the same principles used to calculate the 400kV overhead line expansion constant. The factors are then derived by dividing the calculated expansion constant by the 400kV overhead line expansion constant. The factors will be fixed for each respective price control period. **Formatted: Bullets and Numbering**
- 14.15.62** In calculating the onshore underground cable factors, the forecast costs are weighted equally between urban and rural installation, and direct burial has been assumed. The operating costs for cable are aligned with those for overhead line. An allowance for overhead costs has also been included in the calculations. **Formatted: Bullets and Numbering**
- 14.15.63** The 132kV onshore circuit expansion factor is applied on a TO basis. This is to reflect the regional variation of plans to rebuild circuits at a lower voltage capacity to 400kV. The 132kV cable and line factor is calculated on the proportion of 132kV circuits likely to be uprated to 400kV. The 132kV expansion factor is then calculated by weighting the 132kV cable and overhead line costs with the relevant 400kV expansion factor, based on the proportion of 132kV circuitry to be uprated to 400kV. For example, in the TO areas of National Grid and Scottish Power where there are no plans to uprate any 132kV circuits, the full cable and overhead line costs of 132kV circuit are reflected in the 132kV expansion factor calculation. **Formatted: Bullets and Numbering**
- 14.15.64** The 275kV onshore circuit expansion factor is applied on a GB basis and includes a weighting of 83% of the relevant 400kV cable and overhead line factor. This is to reflect the averaged proportion of circuits across all three Transmission Licensees which are likely to be uprated from 275kV to 400kV across GB within a price control period. **Formatted: Bullets and Numbering**
- 14.15.65** The 400kV onshore circuit expansion factor is applied on a GB basis and reflects the full costs for 400kV cable and overhead lines. **Formatted: Bullets and Numbering**
- 14.15.66** AC sub-sea cable and HVDC circuit expansion factors are calculated on a case by case basis using actual project costs (Specific Circuit Expansion Factors). **Formatted: Bullets and Numbering**
- 14.15.67** For HVDC circuit expansion factors both the cost of the converters and the cost of the cable are included in the calculation. **Formatted: Bullets and Numbering**
- 14.15.68** The TO specific onshore circuit expansion factors calculated for 2008/9 (and rounded to 2 decimal places) are: **Formatted: Bullets and Numbering**

#### Scottish Hydro Region

400kV <u>underground</u> cable factor:	22.39
275kV <u>underground</u> cable factor:	22.39
132kV <u>underground</u> cable factor:	27.79
400kV line factor:	1.00
275kV line factor:	1.14
132kV line factor:	2.24

#### Scottish Power & National Grid Regions

400kV <u>underground</u> cable factor:	22.39
275kV <u>underground</u> cable factor:	22.39
132kV <u>underground</u> cable factor:	30.22
400kV line factor:	1.00
275kV line factor:	1.14
132kV line factor:	2.80

**Onshore Local Circuit Expansion Factors**

**14.15.69** The local onshore circuit tariff is calculated using local onshore circuit expansion factors. These expansion factors are calculated using the same methodology as the onshore wider expansion factor but without taking into account the proportion of circuit kms that are planned to be updated.

**Formatted:** Bullets and Numbering

**14.15.70** In addition, the 132kV onshore overhead line circuit expansion factor is sub divided into four more specific expansion factors. This is based upon maximum (winter) circuit continuous rating (MVA) and route construction whether double or single circuit.

**Formatted:** Bullets and Numbering

400kV <u>underground</u> cable factor:	22.39
275kV <u>underground</u> cable factor:	22.39
132kV <u>underground</u> cable factor:	30.22
400kV line factor:	1.00
275kV line factor:	1.14
132kV line factor (single; <200MVA):	10.00
132kV line factor (double; <200MVA):	8.32
132kV line factor (single; >=200MVA):	7.13
132kV line factor (double; >=200MVA):	4.42

**Offshore Circuit Expansion Factors**

**14.15.71** Offshore expansion factors (£/MWkm) are derived from information provided by Offshore Transmission Owners for each offshore circuit. Offshore expansion factors are Offshore Transmission Owner and circuit specific. Each Offshore Transmission Owner will periodically provide, via the STC, information to derive an annual circuit revenue requirement. The offshore circuit revenue shall include revenues associated with the Offshore Transmission Owner’s reactive compensation equipment, harmonic filtering equipment, asset spares and HVDC converter stations.

**Formatted:** Bullets and Numbering

**14.15.72** In the first year of connection, the offshore circuit expansion factor would be calculated as follows:

**Formatted:** Bullets and Numbering

$$\frac{CRevOFTO1}{L \times CircRat} \div \text{Onshore 400kV OHL Expansion Constant}$$

Where:

- CRevOFTO1 = The offshore circuit revenue in £ for Year 1
- L = The total circuit length in km of the offshore circuit
- CircRat = The continuous rating of the offshore circuit

**14.15.73** In all subsequent years, the offshore circuit expansion factor would be calculated as follows:

**Formatted:** Bullets and Numbering

$$\frac{AvCRevOFTO}{L \times CircRat} \div \text{Onshore 400kV OHL Expansion Constant}$$

Where:

- AvCRevOFTO = The annual offshore circuit revenue averaged over the remaining years of the onshore National Electricity Transmission System Operator (NETSO) price control
- L = The total circuit length in km of the offshore circuit
- CircRat = The continuous rating of the offshore circuit

**14.15.74** Prevailing OFFSHORE TRANSMISSION OWNER specific expansion factors will be published in this statement. These shall be re-calculated at the start of each price control when the onshore expansion constants are revisited.

**Formatted:** Bullets and Numbering

**The Locational Onshore Security Factor**

**Formatted:** 1,2,3, Indent: First line: 0 cm

**14.15.75** The locational onshore security factor is derived by running a secure DCLF ICRP transport study based on the same market background as used for Zoning in the DCLF ICRP transport model. This calculates the nodal marginal costs where peak demand can be met despite the Security and Quality of Supply Standard contingencies (simulating single and double circuit faults) on the network. Essentially the calculation of secured nodal marginal costs is identical to the process outlined above except that the secure DCLF study additionally calculates a nodal marginal cost taking into account the requirement to be secure against a set of worse case contingencies in terms of maximum flow for each circuit.

**Formatted:** Bullets and Numbering

**14.15.76** The secured nodal cost differential is compared to that produced by the DCLF ICRP transport model and the resultant ratio of the two determines the locational security factor using the Least Squares Fit method. Further information may be obtained from the charging website<sup>1</sup>.

**Formatted:** Bullets and Numbering

**14.15.77** The locational onshore security factor derived for 2010/11 is 1.8 and is based on an average from a number of studies conducted by The Company to account for future network developments. The security factor is reviewed for each price control period and fixed for the duration.

**Formatted:** Bullets and Numbering

**Local Security Factors**

**14.15.78** Local onshore security factors are generator specific and are applied to a generators local onshore circuits. If the loss of any one of the local circuits prevents the export of power from the generator to the MITS then a local security factor of 1.0 is applied. For generation with circuit redundancy, a local security factor is applied that is equal to the locational security factor, currently 1.8.

**Formatted:** Bullets and Numbering

**14.15.79** Where a Transmission Owner has designed a local onshore circuit (or otherwise that circuit once built) to a capacity lower than the aggregated TEC of the generation using that circuit, then the local security factor of 1.0 will be multiplied by a Counter Correlation Factor (CCF) as described in the formula below:

**Formatted:** Bullets and Numbering

$$CCF = \frac{D_{min} + T_{cap}}{G_{cap}}$$

Where:  $D_{min}$  = minimum annual net demand (MW) supplied via that circuit in the absence of that generation using the circuit

$T_{cap}$  = transmission capacity built (MVA)

$G_{cap}$  = aggregated TEC of generation using that circuit

CCF cannot be greater than 1.0.

<sup>1</sup> <http://www.nationalgrid.com/uk/Electricity/Charges/>

14.15.80 A specific offshore local security factor (LocalSF) will be calculated for each offshore connection using the following methodology:

Formatted: Bullets and Numbering

$$LocalSF = \frac{NetworkExportCapacity}{\sum_k Gen_k}$$

Where:

NetworkExportCapacity = the total export capacity of the network  
 k = the generation connected to the offshore network

14.15.81 The offshore security factor for single circuits with a single cable will be 1.0 and for multiple circuit connections will be capped at the locational onshore security factor, derived as 1.8 for 2010/11.

Formatted: Bullets and Numbering

Formatted: Indent: Left: 1.27 cm

### Initial Transport Tariff

14.15.82 First an Initial Transport Tariff (ITT) must be calculated for both Peak Security and Year Round backgrounds. For Generation<sub>i</sub>, the Peak Security zonal marginal km (ZMkm<sub>PS</sub>), Year Round Not-Shared zonal marginal km (ZMkm<sub>YRNS</sub>) and Year Round Shared zonal marginal km (ZMkm<sub>YRS</sub>) are simply multiplied by the expansion constant and the locational security factor to give the Peak Security ITT, Year Round Not-Shared ITT and Year Round Shared ITT respectively:

Formatted: Bullets and Numbering

$$ZMkm_{GiPS} \times EC \times LSF = ITT_{GiPS}$$

Deleted: initial transport tariff

Formatted: Font: 11 pt, Highlight

Formatted: Highlight

Deleted:  $ZMkm_{Gi} \times EC \times L$

$$ZMkm_{GiYRNS} \times EC \times LSF = ITT_{GiYRNS}$$

Field Code Changed

Formatted: Highlight

$$ZMkm_{GiYRS} \times EC \times LSF = ITT_{GiYRS}$$

Field Code Changed

Deleted: . = .

Formatted: Highlight

Where

ZMkm<sub>GiPS</sub> = Peak Security Zonal Marginal km for each generation zone

Formatted: Indent: Left: 1.27 cm, Tabs: Not at 2 cm + 2.5 cm + 3 cm

ZMkm<sub>GiYRNS</sub> = Year Round Not-Shared Zonal Marginal km for each generation zone

Formatted: Highlight

ZMkm<sub>GiYRS</sub> = Year Round Shared Zonal Marginal km for each generation zone

Formatted: Highlight

EC = Expansion Constant

Formatted: Highlight

LSF = Locational Security Factor

Formatted: Highlight

ITT<sub>GiPS</sub> = Peak Security Initial Transport Tariff (£/MW) for each generation zone

Deleted: ¶

Deleted: . ITT<sub>Gi</sub> . = .

ITT<sub>GiYRNS</sub> = Year Round Not-Shared Initial Transport Tariff (£/MW) for each generation zone

Formatted: Indent: Left: 1.27 cm

Formatted: Highlight

ITT<sub>GiYRS</sub> = Year Round Shared Initial Transport Tariff (£/MW) for each generation zone

Formatted: Highlight

Formatted: Highlight

Formatted: Highlight

Formatted: Highlight

Formatted: Indent: Left: 1.27 cm

14.15.83 Similarly, for demand the Peak Security zonal marginal km (ZMkm<sub>PS</sub>) and Year Round zonal marginal km (ZMkm<sub>YR</sub>) are simply multiplied by the expansion constant and the locational security factor to give the Peak Security ITT and Year Round ITT respectively:

Formatted: Bullets and Numbering

Deleted: initial transport tariff

$$ZMkm_{DiPS} \times EC \times LSF = ITT_{DiPS}$$

Deleted:  $ZMkm_{Di} \times EC \times I$

$$ZMkm_{DiYR} \times EC \times LSF = ITT_{DiYR}$$

Deleted: . = .

Where

$ZMkm_{DiPS}$  = Peak Security Zonal Marginal km for each demand zone

Deleted: EC . . . = . Expansion Constant

$ZMkm_{DiYR}$  = Year Round Zonal Marginal km for each demand zone

Deleted: LSF . . . = . Locational Security Factor

$ITT_{DiPS}$  = Peak Security Initial Transport Tariff (£/MW) for each demand zone

Formatted: Indent: Left: 1.27 cm, First line: 0 cm

$ITT_{DiYR}$  = Year Round Initial Transport Tariff (£/MW) for each demand zone

Deleted: .  $ITT_{Di}$  . . = .

Formatted: Indent: Left: 1.27 cm

14.15.84 The next step is to multiply these ITTs by the expected metered triad demand and generation capacity to gain an estimate of the initial revenue recovery, for both Peak Security and Year Round backgrounds. The metered triad demand and generation capacity are based on forecasts provided by Users and are confidential.

Formatted: Bullets and Numbering

Deleted: initial transport tariffs

Deleted: . Both of these latter parameters

14.15.85 In addition, the initial tariffs for generation are also multiplied by the Peak Security flag when calculating the initial revenue recovery component for the Peak Security background. Similarly, when calculating the initial revenue recovery for the Shared component of the Year Round background, the initial tariffs are multiplied by the Annual Load Factor (see below).

Formatted: Font: Arial (W1), 11 pt

Formatted: Indent: Left: 1.27 cm

Deleted: .

**Peak Security (PS) Flag**

$$\sum_{Gi=1}^{21} (ITT_{Gi} \times G_{Gi}) = ITRR_G$$

. and

$$\sum_{Di=1}^{14} (ITT_{Di} \times D_{Di}) = ITRR_D$$

14.15.86 The revenue from a specific generator due to the Peak Security locational tariff needs to be multiplied by the appropriate Peak Security (PS) flag. The PS flags indicate the extent to which a generation plant type contributes to the need for transmission network investment at peak demand conditions. The PS flag is derived from the contribution of differing generation sources to the demand security criterion as described in the Security Standard. In the event of a significant change to the demand security assumptions in the Security Standard, National Grid will review the use of the PS flag.

Formatted: Numbered + Level: 1 + Numbering Style: 1, 2, 3, ... + Start at: 1 + Alignment: Left + Aligned at: 1.27 cm + Tab after: 1.27 cm + Indent at: 2.87 cm

Generation Plant Type	PS flag
Intermittent	0
Other	1

Formatted: Font: Arial (W1), 11 pt, Highlight

Deleted: for

**Annual Load Factor (ALF)**

Formatted: Font: Arial (W1), 11 pt

Deleted: ¶

14.15.87 The ALF for each individual Power Station is calculated using the relevant TEC (MW) and corresponding output data. Where output data is not available for a Power Station, including for new Power Stations and emerging Power Station technologies, generic data for the appropriate generation plant type will be used.

Deleted: -----Page Break-----

¶

Formatted: Bullets and Numbering

14.15.88 For a given charging year “t” the Power Station ALF will be based on information from the previous five charging years, calculated for each charging year as set out below.

Deleted: The

Formatted: ... [43]

$$ALF = \frac{\sum_{p=1}^{17520} GMWh_p}{\sum_{p=1}^{17520} TECp \times 0.5}$$

Deleted: ALF for each individual Power Station 1 ... [44]

Formatted: Font: Arial (W1), 11 pt

Formatted: Font: Arial (W1)

Deleted: .  $ITRR_G$  . . = .

Formatted: Bullets and Numbering

Where:

$GMWh_p$  is the maximum of FPN or actual metered output in a Settlement Period related to the power station TEC (MW); and

$TEC_p$  is the TEC (MW) applicable to that Power Station for that Settlement Period including any STTEC and LDTEC, accounting for any trading of TEC.

14.15.89 The appropriate output (FPN or actual metered) figure is derived from BM Unit data available to National Grid and relates to the total TEC of the Power Station.

**Deleted:** balancing mechanism user

**Formatted:** Bullets and Numbering

14.15.90 Once all five charging year ALFs have been calculated for the individual Power Station they are compared, and the highest and lowest figures are discarded. The final ALF, to be used for transmission charging purposes, is calculated as the average of the remaining three ALFs.

**Formatted:** Bullets and Numbering

14.15.91 In the event that only four charging years of complete output (FPN or actual metered) data are available for an individual Power Station then the higher three charging years ALF would be used in the calculation of the final ALF. In the event that only three charging years of complete output (FPN or actual metered) data are available then these three charging years would be used.

**Formatted:** Bullets and Numbering

14.15.92 Due to the aggregation of output (FPN or actual metered) data for dispersed generation (e.g. cascade hydro schemes), where a single generator BMU consists of geographically separated power stations, the ALF would be calculated based on the total output of the BMU and the overall TEC of those Power Stations .

**Formatted:** Bullets and Numbering

14.15.93 In the event that there are not three full charging years of an individual power station's output available, missing output (FPN or actual metered) data would be replaced by generic data for that generation plant type to ensure three charging years of information are available for the Power Station. The derivation of the generic data is described in paragraphs 14.15.97-14.15.100.

**Formatted:** Bullets and Numbering

**Deleted:** 82

**Deleted:** 85

14.15.94 Users will receive draft ALFs before 25<sup>th</sup> December of the charging year (t-1) for the charging year (t) and will have a period of 15 working days from date of publishing to notify the Company of any errors. Failure to agree changes relating to errors will be treated as a charging dispute under the CUSC.

**Formatted:** Bullets and Numbering

14.15.95 The ALFs used in the setting of final tariffs will be published in the annual Statement of Use of System Charges. Changes to ALFs after this publication will not result in changes to published tariffs (e.g. following dispute resolution).

**Formatted:** Bullets and Numbering

**Derivation of Generic ALFs**

**Deleted:** All Power Station ALFs are published in the Statement of Use of System Charges.

14.15.96 The generic ALF is derived from the average annual output of the ten most recently commissioned GB generation of a particular generation plant type that have at least five charging years' data, using an identical methodology to that used for the Power Station specific calculation described above. Where less than ten GB generators of a particular generation plant type exist, then data from all existing generators of that particular generation plant type will be used. Example generation plant type categories are listed below;

**Formatted:** Bullets and Numbering

<b>Fuel Type</b>
Biomass
Coal
Gas
Hydro



<u>Nuclear (by reactor type)</u>
<u>Oil &amp; OCGTs</u>
<u>Pumped Storage</u>
<u>Onshore Wind</u>
<u>Offshore Wind</u>
<u>CHP</u>

14.15.97 The Company will keep these categories under review and update as necessary. Where within a category there is a significant locational difference consideration will be given to zonal generic factors. The factors used will be published in the Statement of Use of System Charges and will be reviewed annually.

**Formatted:** Bullets and Numbering

14.15.98 If a User can demonstrate that the generation plant type of a Power Station has changed, consideration will be given to the use of relevant generic ALF information in the calculation of their charges until sufficient specific data is available.

**Deleted:** u

**Formatted:** Bullets and Numbering

14.15.99 For new and emerging generation plant types, where insufficient data is available to allow a generic ALF to be developed, The Company will use the best information available e.g. from manufactures and data from use of similar technologies outside GB. The factor will be agreed with the relevant Generator. In the event of a disagreement the standard provisions for dispute in the CUSC will apply.

**Formatted:** Bullets and Numbering

**Initial Revenue Recovery**

14.15.100 For the Peak Security background the initial tariff for generation is multiplied by the total forecast generation capacity and the PS flag to give the initial revenue recovery:

**Formatted:** Bullets and Numbering

$$\sum_{Gi=1}^n (ITT_{GiPS} \times G_{Gi} \times F_{PS}) = ITRR_{GPS}$$

**Field Code Changed**

Where

- ITRR<sub>GPS</sub> = Peak Security Initial Transport Revenue Recovery for generation
- G<sub>Gi</sub> = Total forecast Generation for each generation zone (based on confidential User forecasts)
- F<sub>PS</sub> = Peak Security flag appropriate to that generator type
- n = number of generation zones

**Formatted:** Font: Arial (W1), 11 pt

**Formatted:** 1,2,3, Justified

**Deleted:** . ITRR<sub>DPS</sub> = .

The initial revenue recovery for demand for the Peak Security background is calculated by multiplying the initial tariff by the total forecast metered triad demand:

$$\sum_{Di=1}^{14} (ITT_{DiPS} \times D_{Di}) = ITRR_{DPS}$$

Where:

- ITRR<sub>DPS</sub> = Peak Security Initial Transport Revenue Recovery for demand
- D<sub>Di</sub> = Total forecast Metered Triad Demand for each demand zone (based on confidential User forecasts)

**Formatted:** Font: Arial (W1), 11 pt

**Formatted:** Indent: Left: 1.27 cm

14.15.101 For the Year Round background, the initial tariff for generation is multiplied by the total forecast generation capacity whilst calculating Initial Recovery for Not-Shared component whereas the initial tariff for Shared component is multiplied by both, the total forecast generation capacity and the ALF to give the initial revenue recovery:

$$\sum_{Gi=1}^n (ITT_{GYRNS} \times G_{Gi}) = ITRR_{GYRNS}$$

$$\sum_{Gi=1}^n (ITT_{GYRS} \times G_{Gi} \times ALF) = ITRR_{GYRS}$$

Where:

$ITRR_{GYRNS}$  = Year Round Not-Shared Initial Transport Revenue Recovery for generation

$ITRR_{GYRS}$  = Year Round Shared Initial Transport Revenue Recovery for generation

ALF = Annual Load Factor appropriate to that generator

14.15.102 Similar to the Peak Security background, the initial revenue recovery for demand for the Year Round background is calculated by multiplying the initial tariff by the total forecast metered triad demand:

$$\sum_{Di=1}^{14} (ITT_{DYSR} \times D_{Di}) = ITRR_{DYSR}$$

Where:

$ITRR_{DYSR}$  = Year Round Initial Transport Revenue Recovery for demand

### Deriving the Final Local Tariff (£/kW)

#### Local Circuit Tariff

14.15.103 Generation with a local circuit tariff is calculated by multiplying the Year Round nodal marginal km along the local circuit by the expansion constant and the relevant local security factor (whether onshore or offshore) and summing across local circuits to give the local circuit tariff:

$$\sum_k \frac{NLMkm_{Gj}^L \times EC \times LocalSF_k}{1000} = CLT_{Gi}$$

Where

$k$  = Local circuit  $k$  for generator

$NLMkm_{Gj}^L$  = Year Round Nodal marginal km along local circuit  $k$  using local circuit expansion factor.

EC = Expansion Constant

$LocalSF_k$  = Local Security Factor for circuit  $k$

$CLT_{Gi}$  = Circuit Local Tariff (£/kW)

#### Onshore Local Substation Tariff

Deleted: <#>The next stage is to correct the Initial Transport Revenue Recovery figures above such that the 'correct' split of revenue between generation and demand is obtained. This has been determined to be 27:73 by the Authority for generation and demand respectively. In order to achieve the 'correct' generation/demand revenue split, a single additive constant C is calculated which is then added to the total zonal marginal km, both for generation and demand as below: ¶

Formatted: Font: 11 pt, Highlight

Formatted: Font: Times New Roman, 11 pt, Highlight

Formatted: Font: 11 pt, Highlight

Formatted: Bullets and Numbering

Formatted: Highlight

Formatted: Highlight

Field Code Changed

Deleted:  $\sum_{Gi=1}^{21} [(ZMkm_{Gi} + C$  ¶ ... [45]

Formatted: Highlight

Formatted: Highlight

Formatted: Highlight

Formatted: Highlight

Formatted: Highlight

Formatted: Highlight

Formatted: Font: 12 pt, Highlight

Formatted: Highlight

Formatted: Font: 11 pt, Highlight

Formatted: Indent: Left: 1.27 cm

Formatted: Font: 11 pt, Highlight

Formatted: Highlight

Formatted: Font: 11 pt, Highlight

Formatted: Font: 11 pt, Highlight

Formatted: Bullets and Numbering

Deleted:  $CTRR_D = p(CTI$

Deleted: ¶ ... [46]

Formatted: Justified

Formatted: Bullets and Numbering

**14.15.104** All chargeable generation is subject to the local substation tariff component which is determined by assessing the generation substation type which is the substation at the connection charging boundary, against three cost determining factors:

Formatted: Bullets and Numbering

- (a) HV connection voltage – the voltage at the boundary between the User’s connection assets and the transmission system;
- (b) Sum of TEC at the generation substation – the combined TEC of all generation at the connecting substation; and
- (c) The level of redundancy at the generation substation – single busbar / single switch mesh connections are examples of no redundancy connections, whereas examples of connections with redundancy include double busbar and mesh sub station designs.

**14.15.105** Using the above factors, the corresponding £/kW tariffs (quoted to 3dp) that will be applied during 2010/11 are:

Formatted: Bullets and Numbering

Substation Rating (b)	Connection Type (c)	Substation Voltage (a)		
		132kV	275kV	400kV
<1320MW	No redundancy	0.133	0.081	0.065
<1320MW	Redundancy	0.301	0.192	0.155
>=1320MW	No redundancy	n/a	0.257	0.208
>=1320MW	Redundancy	n/a	0.417	0.336

**14.15.106** The process for calculating Local Substation Tariffs will be carried out for the first year of the price control and will subsequently be indexed by RPI for each subsequent year of the price control period.

Formatted: Bullets and Numbering

**14.15.107** The effective **Local Tariff** (£/kW) is calculated as the sum of the circuit and substation onshore and/or offshore components:

Formatted: Bullets and Numbering

$$ELT_{Gi} = CLT_{Gi} + SLT_{Gi}$$

Where

ELT<sub>Gi</sub> = Effective Local Tariff (£/kW)

SLT<sub>Gi</sub> = Substation Local Tariff (£/kW)

**14.15.108** Where tariffs do not change mid way through a charging year, final local tariffs will be the same as the effective tariffs:

Formatted: Bullets and Numbering

ELT<sub>Gi</sub> = LT<sub>Gi</sub>

Where

LT<sub>Gi</sub> = Final Local Tariff (£/kW)

**14.15.109** Where tariffs are changed part way through the year, the final tariffs will be calculated by scaling the effective tariffs to reflect that the tariffs are only applicable for part of the year and parties may have already incurred TNUoS liability.

Formatted: Bullets and Numbering

$$FT_{Gi} = \frac{12 \times \left( ET_{Gi} \times \sum_{Gi=1}^n G_{Gi} - FL_{Gi} \right)}{b \times \sum_{Gi=1}^n G_{Gi}} \quad \text{and} \quad FT_{Di} = \frac{12 \times \left( ET_{Di} \times \sum_{Di=1}^{14} D_{Di} - FL_{Di} \right)}{b \times \sum_{Di=1}^{14} D_{Di}}$$

Field Code Changed

Field Code Changed

Where:

b = number of months the revised tariff is applicable for

FLL = Forecast local liability incurred over the period that the original tariff is applicable for

**14.15.110** For the purposes of charge setting, the total local charge revenue is calculated by: Formatted: Bullets and Numbering

$$LCRR_G = \sum_{j=Gi} LT_{Gi} * G_j$$

Where  
 LCRR<sub>G</sub> = Local Charge Revenue Recovery  
 G<sub>j</sub> = Forecast chargeable Generation or Transmission Entry Capacity in kW (as applicable) for each generator (based on confidential information received from Users)

**Offshore substation local tariff**

**14.15.111** All offshore chargeable generation is subject to an offshore substation tariff. The offshore substation tariff shall be the sum of transformer, switchgear and platform components. Formatted: Bullets and Numbering

**14.15.112** Each tariff component, expressed in £/kW, shall be the ratio of the Offshore Transmission Owner revenue (£) and rating associated with the transformers, switchgear or platform (kW) at each offshore substation. The Offshore Transmission Owner revenue of each tariff component shall include that associated with asset spares. In the case of the platform component, the relevant rating shall be the lower of the transformer or switchgear ratings. As with the offshore circuit expansion factors, the Offshore Transmission Owner revenue associated with each tariff component shall be averaged over the remaining years of the NETSO price control. Formatted: Bullets and Numbering

**14.15.113** Offshore Transmission Owner revenue associated with interest during construction and project development overheads will be attributed to the relevant asset category with which it is associated. If these or any other costs included in the Offshore Transmission Owner revenue are not readily attributable to a given asset category, they will be pro-rated across the various asset categories based on their relative cost. Formatted: Bullets and Numbering

**14.15.114** For 2010/11 a discount of £0.345590/kW shall be provided to the offshore substation tariff to reflect the average cost of civil engineering for onshore substations. This will be inflated by RPI each year and reviewed every price control period. Formatted: Bullets and Numbering

**14.15.115** Offshore substation tariffs shall be inflated by RPI each year and reviewed every price control period. Formatted: Bullets and Numbering

**14.15.116** The revenue from the offshore substation local tariff is calculated by: Formatted: Bullets and Numbering

$$SLTR = \sum_{\text{All offshore substations}} \left( SLT_k \times \sum_k Gen_k \right)$$

Where:  
 SLT<sub>k</sub> = the offshore substation tariff for substation k  
 Gen<sub>k</sub> = the generation connected to offshore substation k

**The Residual Tariff**

**14.15.117** The total revenue to be recovered through TNUoS charges is determined each year with reference to the Transmission Licensees' Price Control formulas less the costs expected to be recovered through Pre-Vesting connection charges. Hence in any given year t, a target revenue figure for TNUoS charges (TRR<sub>t</sub>) is set after adjusting for Formatted: Bullets and Numbering

any under or over recovery for and including, the small generators discount is as follows:

$$TRR_t = R_t - PVC_t - SG_{t-1}$$

Where

- TRR<sub>t</sub> = TNUoS Revenue Recovery target for year t
- R<sub>t</sub> = Forecast Revenue allowed under The Company's RPI-X Price Control Formula for year t (this term includes a number of adjustments, including for over/under recovery from the previous year). For further information, refer to Special Condition D2 of The Company's Transmission Licence.
- PVC<sub>t</sub> = Forecast Revenue from Pre-Vesting connection charges for year t
- SG<sub>t-1</sub> = The proportion of the under/over recovery included within R<sub>t</sub> which relates to the operation of statement C13 of the The Company Transmission Licence. Should the operation of statement C13 result in an under recovery in year t – 1, the SG figure will be positive and vice versa for an over recovery.

**14.15.118** In normal circumstances, the revenue forecast to be recovered from the initial transport tariffs will not equate to the total revenue target. This is due to a number of factors. For example, the transport model assumes, for simplicity, smooth incremental transmission investments can be made. In reality, transmission investment can only be made in discrete 'lumps'. The transmission system has been planned and developed over a long period of time. Forecasts and assessments used for planning purposes will not have been borne out precisely by events and therefore some distinction between an optimal system for one year and the actual system can be expected.

**Formatted:** Bullets and Numbering  
**Deleted:** corrected

**14.15.119** As a result of the factors above, in order to ensure adequate revenue recovery, a constant non-locational **Residual Tariff** for generation and demand is calculated, which includes infrastructure substation asset costs. It is added to the initial transport tariffs for both Peak Security and Year Round backgrounds so that the correct generation / demand revenue split is maintained and the total revenue recovery is achieved.

**Formatted:** Bullets and Numbering  
**Deleted:** corrected

$$RT_D = \frac{(p \times TRR) - ITRR_{DPS} - ITRR_{DYS}}{\sum_{Di=1}^{14} D_{Di}}$$

$$RT_G = \frac{[(1-p) \times TRR] - ITRR_{GPS} - ITRR_{GYRNS} - ITRR_{GYRS} - LCRR_G}{\sum_{Gi=1}^n G_{Gi}}$$

**Deleted:**  $RT_D = \frac{(p \times TRR)}{\sum_{Di=1}^{14}}$

**Field Code Changed**

**Deleted:**  $RT_G = [(1-p) \times$

- Where
- RT = Residual Tariff (£/MW)
- p = Proportion of revenue to be recovered from demand

**Formatted:** Font: Arial, 11 pt

**Formatted:** Font: Arial

**Formatted:** Bullets and Numbering

**Deleted:** corrected

**Field Code Changed**

**Final £/kW Tariff**

**14.15.120** The effective Transmission Network Use of System tariff (TNUoS) can now be calculated as the sum of the initial transport wider tariffs for Peak Security and Year Round backgrounds, the non-locational residual tariff and the local tariff:

**Deleted:**  $ET_{Gi} = \frac{ITT_{Gi}^{PS}}{1000} +$

**Deleted:**

**Deleted:**  $ET_{Di} = \frac{ITT_{Di}^{PS} + ITT_{Di}^{YR}}{1000}$

$$ET_{Gi} = \frac{ITT_{GiPS} + ITT_{GiYRNS} + ITT_{GiYRS} + RT_G + LT_{Gi}}{1000} \text{ and } ET_{Di} = \frac{ITT_{DiPS} + ITT_{DiYR} + RT_D}{1000}$$

Where:

**Formatted:** Font: Arial, 11 pt

**Formatted:** Font: Arial

ET = Effective TNUoS Tariff expressed in £/kW (ET<sub>Gi</sub> would only be applicable to a Power Station with a PS flag of 1 and ALF of 1; in all other circumstances ITT<sub>GiPS</sub>, ITT<sub>GiYRNS</sub> and ITT<sub>GiYRS</sub> will be applied using Power Station specific data)

Formatted: Indent: Left: 0.46 cm, Tabs: Not at 2 cm  
Formatted: Highlight

For the purposes of the annual Statement of Use of System Charges ET<sub>Gi</sub> will be published as ITT<sub>GiPS</sub>; ITT<sub>GiYRNS</sub>; ITT<sub>GiYRS</sub>; RT<sub>G</sub> and LT<sub>Gi</sub>

Formatted: Highlight

14.15.121 Where tariffs do not change mid way through a charging year, final demand and generation tariffs will be the same as the effective tariffs.

Formatted: Bullets and Numbering

$$FT_{Gi} = ET_{Gi} \quad \text{and} \quad FT_{Di} = ET_{Di}$$

14.15.122 Where tariffs are changed part way through the year, the final tariffs will be calculated by scaling the effective tariffs to reflect that the tariffs are only applicable for part of the year and parties may have already incurred TNUoS liability.

Formatted: Bullets and Numbering

$$FT_{Gi} = \frac{12 \times \left( ET_{Gi} \times \sum_{Gi=1}^n G_{Gi} - FL_{Gi} \right)}{b \times \sum_{Gi=1}^n G_{Gi}} \quad \text{and} \quad FT_{Di} = \frac{12 \times \left( ET_{Di} \times \sum_{Di=1}^{14} D_{Di} - FL_{Di} \right)}{b \times \sum_{Di=1}^{14} D_{Di}}$$

Field Code Changed

Deleted:  $FT_{Gi} = \frac{12 \times \left( ET_{Gi} \times \sum_{Gi=1}^n G_{Gi} - FL_{Gi} \right)}{b \times \sum_{Gi=1}^n G_{Gi}}$   
Deleted:

Where:

b = number of months the revised tariff is applicable for

FL = Forecast liability incurred over the period that the original tariff is applicable for

Note: The ET<sub>Gi</sub> element used in the formula above will be based on an individual Power Stations PS flag and ALF for Power Station G<sub>Gi</sub>, aggregated to ensure overall correct revenue recovery.

14.15.123 If the final demand TNUoS Tariff results in a negative number then this is collared to £0/kW with the resultant non-recovered revenue smeared over the remaining demand zones:

Formatted: Bullets and Numbering

$$\text{If } FT_{Di} < 0, \quad \text{then } i = 1 \text{ to } z$$

$$\text{Therefore, } NRRT_D = \frac{\sum_{i=1}^z (FT_{Di} \times D_{Di})}{\sum_{i=z+1}^{14} D_{Di}}$$

Therefore the revised Final Tariff for the demand zones with positive Final tariffs is given by:

$$\text{For } i = 1 \text{ to } z: \quad RFT_{Di} = 0$$

Field Code Changed

$$\text{For } i = z + 1 \text{ to } 14: \quad RFT_{Di} = FT_{Di} + NRRT_D$$

Field Code Changed

Where

NRRT<sub>D</sub> = Non Recovered Revenue Tariff (£/kW)

RFT<sub>Di</sub> = Revised Final Tariff (£/kW)

14.15.124 The tariffs applicable for any particular year are detailed in The Company's Statement of Use of System Charges, which is available from the Charging website. Archived tariff information may also be obtained from the Charging website.

Formatted: Bullets and Numbering

**14.15.125** The zonal maps referenced in The Company's **Statement of Use of System Charges** and available on the **Charging website** contain detailed information for the charging year in question of which Grid Supply Points fall into which TNUoS zones.

**Formatted:** Bullets and Numbering

**14.15.126** New Grid Supply Points will be classified into zones on the following basis:

**Formatted:** Bullets and Numbering

- For demand zones, according to the GSP Group to which the Grid Supply Point is allocated for energy market settlement purposes.
- For generation zones, with reference to the geographic proximity to existing zones and, where close to a boundary between existing zones, with reference to the marginal costs arising from transport model studies. The GSP will then be allocated to the zone, which contains the most similar marginal costs.

**Formatted:** Indent: Left: 1.25 cm, Hanging: 0.75 cm, Bulleted + Level: 1 + Aligned at: 0 cm + Tab after: 0.63 cm + Indent at: 0.63 cm, Tabs: 2 cm, List tab + Not at 0.63 cm + 1.27 cm

**Formatted:** Indent: Left: 1.25 cm, Hanging: 0.75 cm, Bulleted + Level: 1 + Aligned at: 0 cm + Tab after: 0.63 cm + Indent at: 0.63 cm, Tabs: 2 cm, List tab + Not at 0.63 cm + 1.27 cm

**Formatted:** Bullets and Numbering

**14.15.127** The Company has available, upon request, the DCLF ICRP transport model, tariff model template and data necessary to run the model, consisting of nodal values of generation and demand connection points to the NETS. The model and data will enable the basic nodal charges to be determined and will also allow sensitivity analysis concerning alternative developments of generation and demand to be undertaken. The model is available from the Charging Team and whilst it is free of charge, it is provided under licence to restrict its distribution and commercial use.

**14.15.128** The Company will be pleased to run specific sensitivity studies for Users under a separate study contract in line with the fees set out in the **Statement of Use of System Charges**. Please contact the **Charging Team**.

**Formatted:** Bullets and Numbering

**14.15.129** The factors which will affect the level of TNUoS charges from year to year include:

**Formatted:** Bullets and Numbering

- the forecast level of peak demand on the system,
- the Price Control formula (including the effect of any under/over recovery from the previous year),
- the expansion constant,
- the locational security factor,
- the PS flag
- the ALF of a generator
- changes in the transmission network,
- HVDC circuit impedance calculation
- changes in the pattern of generation capacity and demand,

**Deleted:**

**Deleted:** ,

**Deleted:** ),

**Deleted:** ,

**Deleted:** ,

**Deleted:** and

**Formatted:** Bulleted + Level: 1 + Aligned at: 3.81 cm + Tab after: 4.51 cm + Indent at: 4.51 cm, Tabs: Not at 1.27 cm

**Deleted:** .

**Formatted:** Bullets and Numbering

**14.15.130** In accordance with Standard Licence Condition C13, generation directly connected to the NETS 132kV transmission network which would normally be subject to generation TNUoS charges but would not, on the basis of generating capacity, be liable for charges if it were connected to a licensed distribution network qualifies for a reduction in transmission charges by a designated sum, determined by the Authority. Any shortfall in recovery will result in a unit amount increase in demand charges to compensate for the deficit. Further information is provided in the Statement of the Use of System Charges.

**Stability & Predictability of TNUoS tariffs**

**14.15.131** A number of provisions are included within the methodology to promote the stability and predictability of TNUoS tariffs. These are described in 14.29.

**Formatted:** Bullets and Numbering

**Deleted:** 8

## 14.16 Derivation of the Transmission Network Use of System Energy Consumption Tariff and Short Term Capacity Tariffs

- 14.16.1 For the purposes of this section, Lead Parties of Balancing Mechanism (BM) Units that are liable for Transmission Network Use of System Demand Charges are termed Suppliers.
- 14.16.2 Following calculation of the Transmission Network Use of System £/kW Demand Tariff (as outlined in Chapter 2: Derivation of the TNUoS Tariff) for each GSP Group is calculated as follows:

$$\text{p/kWh Tariff} = \frac{(\text{NHHD}_F * \text{£/kW Tariff} - \text{FL}_G)}{\text{NHHC}_G} * 100$$

Where:

**£/kW Tariff** = The £/kW Effective Demand Tariff (£/kW), as calculated previously, for the GSP Group concerned.

**NHHD<sub>F</sub>** = The Company's forecast of Suppliers' non-half-hourly metered Triad Demand (kW) for the GSP Group concerned. The forecast is based on historical data.

**FL<sub>G</sub>** = Forecast Liability incurred for the GSP Group concerned.

**NHHC<sub>G</sub>** = The Company's forecast of GSP Group non-half-hourly metered total energy consumption (kWh) for the period 16:00 hrs to 19:00hrs inclusive (i.e. settlement periods 33 to 38) inclusive over the period the tariff is applicable for the GSP Group concerned.

### Short Term Transmission Entry Capacity (STTEC) Tariff

- 14.16.3 The Short Term Transmission Entry Capacity (STTEC) tariff for positive zones is derived from the Effective Tariff (ET<sub>Gi</sub>) annual TNUoS £/kW tariffs (14.15.109). If multiple set of tariffs are applicable within a single charging year, the Final Tariff used in the STTEC calculation will be prorated in an identical manner to that used when calculating a generators annual liability. The periods over which the tariff would be prorated would be identical to the periods used when calculating the wider tariff (i.e. over the whole financial year, not just the period that the STTEC is applicable for). STTECs will not be reconciled following a mid year charge change. The premium associated with the flexible product is associated with the analysis that 90% of the annual charge is linked to the system peak. The system peak is likely to occur in the period of November to February inclusive (120 days, irrespective of leap years). The calculation for positive generation zones is as follows:

Deleted: relevant

$$\frac{FT_{Gi} \times 0.9 \times \text{STTEC Period}}{120} = \text{STTEC tariff (£/kW/period)}$$

Where:

- FT = Final annual TNUoS Tariff expressed in £/kW  
 Gi = Generation zone  
 STTEC Period = A period applied for in days as defined in the CUSC



14.16.4 For the avoidance of doubt, the charge calculated under 14.16.3 above will represent each single period application for STTEC. Requests for multiple STTEC periods will result in each STTEC period being calculated and invoiced separately.

14.16.5 The STTEC tariff for generators with negative final tariffs is set to zero to prevent Users receiving greater than 100% of the annual TNUoS payment that would have been received for that capacity under a firm TEC.

### Limited Duration Transmission Entry Capacity (LDTEC) Tariffs

14.16.6 The Limited Duration Transmission Entry Capacity (LDTEC) tariff for positive zones is derived from the equivalent zonal STTEC tariff for up to the initial 17 weeks of LDTEC in a given charging year (whether consecutive or not). For the remaining weeks of the year, the LDTEC tariff is set to collect the balance of the annual TNUoS liability over the maximum duration of LDTEC that can be granted in a single application. If multiple set of tariffs are applicable within a single charging year, the Final Tariff used in the LDTEC calculation will be prorated in an identical manner to that used when calculating a generators annual liability. The periods over which the tariff would be prorated would be identical to the periods used when calculating the wider tariff (ie over the whole financial year, not just the period that the STTEC is applicable for). LDTECs will not be reconciled following a mid year charge change:

Initial 17 weeks (high rate):

$$\text{LDTEC tariff (£/kW/week)} = \frac{FT_{G_i} \times 0.9 \times 7}{120}$$

Remaining weeks (low rate):

$$\text{LDTEC tariff (£/kW/week)} = \frac{FT_{G_i} \times 0.1075 \times 7}{316 - 120} \times (1 + P)$$

where  $FT$  is the final annual TNUoS tariff expressed in £/kW;

$G_i$  is the generation TNUoS zone; and

$P$  is the premium in % above the annual equivalent TNUoS charge as determined by The Company, which shall have the value 0.

14.16.7 The LDTEC tariff for generators with negative final tariffs is set to zero to prevent Users receiving greater than 100% of the annual TNUoS payment that would have been received for that capacity under a firm TEC.

14.16.8 The tariffs applicable for any particular year are detailed in The Company's **Statement of Use of System Charges** which is available from the **Charging website**. Historical tariffs are also available on the **Charging website**.

## 14.17 Demand Charges

### Parties Liable for Demand Charges

14.17.1 The following parties shall be liable for demand charges:

- The Lead Party of a Supplier BM Unit;
- Power Stations with a Bilateral Connection Agreement;
- Parties with a Bilateral Embedded Generation Agreement

14.17.2 14.26 Classification of parties for charging purposes provides an illustration of how a party is classified in the context of Use of System charging and refers to the paragraphs most pertinent to each party.

### Basis of Demand Charges

14.17.3 Demand charges are based on a de-minimus £0/kW charge for Half Hourly and £0/kWh for Non Half Hourly metered demand.

14.17.4 Chargeable Demand Capacity is the value of Triad demand (kW). Chargeable Energy Capacity is the energy consumption (kWh). The definition of both these terms is set out below.

14.17.5 If there is a single set of demand tariffs within a charging year, the Chargeable Demand Capacity is multiplied by the relevant demand tariff, for the calculation of demand charges.

14.17.6 If there is a single set of energy tariffs within a charging year, the Chargeable Energy Capacity is multiplied by the relevant energy consumption tariff for the calculation of energy charges..

14.17.7 If multiple sets of demand tariffs are applicable within a single charging year, demand charges will be calculated by multiplying the Chargeable Demand Capacity by the relevant tariffs pro rated across the months that they are applicable for, as below,

$$Annual\ Liability_{Demand} = Chargeable\ Demand\ Capacity \times \left( \frac{(a \times Tariff\ 1) + (b \times Tariff\ 2)}{12} \right)$$

where:

Tariff 1 = Original tariff,

Tariff 2 = Revised tariff,

a = Number of months over which the original tariff is applicable,

b = Number of months over which the revised tariff is applicable.

**Formatted:** Indent: Left: 2.54 cm, Bulleted + Level: 1 + Aligned at: 0 cm + Tab after: 0.63 cm + Indent at: 0.63 cm, Tabs: 2.54 cm, List tab + Not at 0.63 cm + 1.27 cm

**Formatted:** Indent: Left: 2.54 cm, Bulleted + Level: 1 + Aligned at: 0 cm + Tab after: 0.63 cm + Indent at: 0.63 cm, Tabs: 2.54 cm, List tab + Not at 0.63 cm + 1.27 cm

**Formatted:** Indent: Left: 2.54 cm, Bulleted + Level: 1 + Aligned at: 0 cm + Tab after: 0.63 cm + Indent at: 0.63 cm, Tabs: 2.54 cm, List tab + Not at 0.63 cm + 1.27 cm

**Deleted:** 5

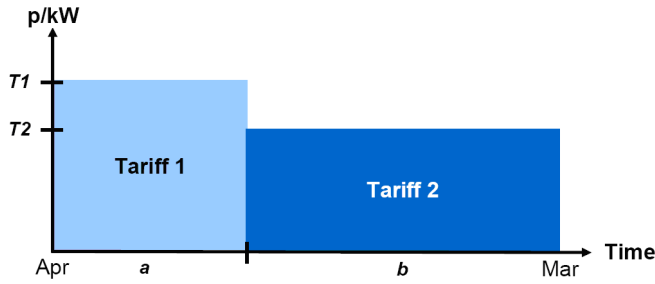

14.17.8 If multiple sets of energy tariffs are applicable within a single charging year, energy charges will be calculated by multiplying relevant Tariffs by the Chargeable Energy Capacity over the period that that the tariffs are applicable for and summing over the year.

$$Annual Liability_{Energy} = Tariff\ 1 \times \sum_{T1_s}^{T1_E} Chargeable\ Energy\ Capacity + Tariff\ 2 \times \sum_{T2_s}^{T2_E} Chargeable\ Energy\ Capacity$$

Where:

- T1<sub>s</sub> = Start date for the period for which the original tariff is applicable,
- T1<sub>E</sub> = End date for the period for which the original tariff is applicable,
- T2<sub>s</sub> = Start date for the period for which the revised tariff is applicable,
- T2<sub>E</sub> = End date for the period for which the revised tariff is applicable.

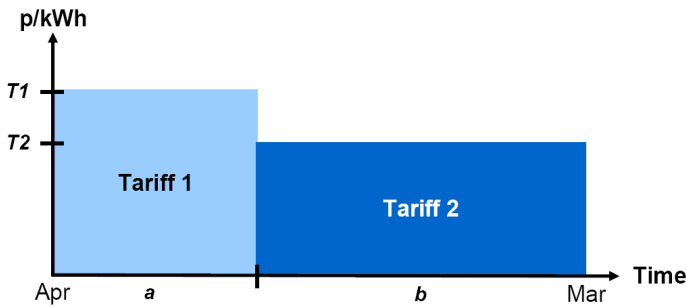

**Supplier BM Unit**

14.17.9 A Supplier BM Unit charges will be the sum of its energy and demand liabilities where::

- The Chargeable Demand Capacity will be the average of the Supplier BM Unit's half-hourly metered demand during the Triad (and the £/kW tariff), and
- The Chargeable Energy Capacity will be the Supplier BM Unit's non half-hourly metered energy consumption over the period 16:00 hrs to 19:00 hrs inclusive every day over the Financial Year (and the p/kWh tariff).

**Formatted:** Indent: Left: 2.5 cm, Bulleted + Level: 1 + Aligned at: 0 cm + Tab after: 0.63 cm + Indent at: 0.63 cm, Tabs: 3.14 cm, List tab + Not at 0.63 cm + 1.27 cm

**Formatted:** Indent: Left: 2.48 cm, Bulleted + Level: 1 + Aligned at: 0 cm + Tab after: 0.63 cm + Indent at: 0.63 cm, Tabs: 3.12 cm, List tab + Not at 0.63 cm + 1.27 cm

**Power Stations with a Bilateral Connection Agreement and Licensable Generation with a Bilateral Embedded Generation Agreement**

14.17.10 The Chargeable Demand Capacity for a Power Station with a Bilateral Connection Agreement or Licensable Generation with a Bilateral Embedded Generation Agreement will be based on the average of the net import over each Triad leg of the BM Units associated with the Power Station (in Appendix C of its Bilateral Connection Agreement or Bilateral Embedded Generation Agreement, including metered additional load) during the Triad.

**Exemptible Generation and Derogated Distribution Interconnectors with a Bilateral Embedded Generation Agreement**

14.17.11 The Chargeable Demand Capacity for Exemptible Generation and Derogated Distribution Interconnectors with a Bilateral Embedded Generation Agreement will be based on the average of the metered volume of each BM Unit specified in Appendix C of the Bilateral Embedded Generation Agreement during the Triad.

**Small Generators Tariffs**

14.17.12 In accordance with Standard Licence Condition C13, any under recovery from the MAR arising from the small generators discount will result in a unit amount of increase to all GB demand tariffs.

**The Triad**

14.17.13 The Triad is used as a short hand way to describe the three settlement periods of highest transmission system demand within a Financial Year, namely the half hour settlement period of system peak demand and the two half hour settlement periods of next highest demand, which are separated from the system peak demand and from each other by at least 10 Clear Days, between November and February of the Financial Year inclusive. Exports on directly connected Interconnectors and Interconnectors capable of exporting more than 100MW to the Total System shall be excluded when determining the system peak demand. An illustration is shown below.

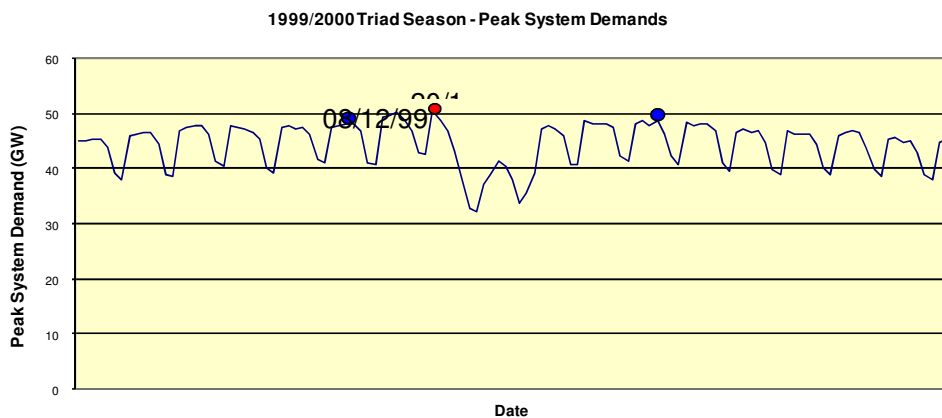

**Half-hourly metered demand charges**

14.17.14 For Supplier BMUs and BM Units associated with Exemptible Generation and Derogated Distribution Interconnectors with a Bilateral Embedded Generation

Agreement, if the average half-hourly metered volume over the Triad results in an import, the Chargeable Demand Capacity will be positive resulting in the BMU being charged. If the average half-hourly metered volume over the Triad results in an export, the Chargeable Demand Capacity will be negative resulting in the BMU being paid. For the avoidance of doubt, parties with Bilateral Embedded Generation Agreements that are liable for Generation charges will not be eligible for a negative demand credit.

**Netting off within a BM Unit**

14.17.15 The output of generators and Distribution Interconnectors registered as part of a Supplier BM Unit will have already been accounted for in the Supplier BM Unit demand figures upon which The Company Transmission Network Use of System Demand charges are based.

**Monthly Charges**

14.17.16 Throughout the year Users' monthly demand charges will be based on their forecasts of:

- half-hourly metered demand to be supplied during the Triad for each BM Unit, multiplied by the relevant zonal £/kW tariff; and
- non-half hourly metered energy to be supplied over the period 16:00 hrs to 19:00 hrs inclusive every day over the Financial Year for each BM Unit, multiplied by the relevant zonal p/kWh tariff

Users' annual TNUoS demand charges are based on these forecasts and are split evenly over the 12 months of the year. Users have the opportunity to vary their demand forecasts on a quarterly basis over the course of the year, with the demand forecast requested in February relating to the next Financial Year. Users will be notified of the timescales and process for each of the quarterly updates. The Company will revise the monthly Transmission Network Use of System demand charges by calculating the annual charge based on the new forecast, subtracting the amount paid to date, and splitting the remainder evenly over the remaining months. For the avoidance of doubt, only positive demand forecasts (i.e. representing an import from the system) will be accepted.

**Formatted:** Indent: Left: 2.54 cm, Hanging: 0.75 cm, Bulleted + Level: 1 + Aligned at: 0 cm + Tab after: 0.63 cm + Indent at: 0.63 cm, Tabs: 3.29 cm, List tab + Not at 0.63 cm + 1.27 cm

**Formatted:** Indent: Left: 2.54 cm, Hanging: 0.75 cm, Bulleted + Level: 1 + Aligned at: 0 cm + Tab after: 0.63 cm + Indent at: 0.63 cm, Tabs: 3.29 cm, List tab + Not at 0.63 cm + 1.27 cm

14.17.17 Users should submit reasonable demand forecasts in accordance with the CUSC. The Company shall use the following methodology to derive a forecast to be used in determining whether a User's forecast is reasonable, in accordance with the CUSC, and this will be used as a replacement forecast if the User's total forecast is deemed unreasonable. The Company will, at all times, use the latest available Settlement data.

For existing Users:

- i)      The User's Triad demand for the preceding Financial Year will be used where User settlement data is available and where The Company calculates its forecast before the Financial Year. Otherwise, the User's average weekday settlement period 35 half-hourly metered (HH) demand in the Financial Year to date is compared to the equivalent average demand for the corresponding days in the preceding year. The percentage difference is then applied to the User's HH demand at Triad in the preceding Financial Year to derive a forecast of the User's HH demand at Triad for this Financial Year.
- ii)      The User's non half-hourly metered (NHH) energy consumption over the period 16:00 hrs to 19:00 hrs every day in the Financial Year to date is compared to the equivalent energy consumption over the corresponding days in the preceding year. The percentage difference is then applied to the User's total NHH energy

**Formatted:** Indent: Left: 2.87 cm, Numbered + Level: 1 + Numbering Style: i, ii, iii, ... + Start at: 1 + Alignment: Left + Aligned at: 0 cm + Tab after: 1 cm + Indent at: 1 cm, Tabs: 2.62 cm, List tab + Not at 1 cm + 1.27 cm

**Formatted:** Indent: Left: 2.87 cm, Numbered + Level: 1 + Numbering Style: i, ii, iii, ... + Start at: 2 + Alignment: Tab + Aligned at: 0 cm + Tab after: 1 cm + Indent at: 1 cm, Tabs: 2.62 cm, List tab + Not at 1 cm + 1.27 cm

consumption in the preceding Financial Year to derive a forecast of the User's NHH energy consumption for this Financial Year.

For new Users who have completed a Use of System Supply Confirmation Notice in the current Financial Year:

iii) The User's average weekday settlement period 35 half-hourly metered (HH)\* demand over the last complete month for which The Company has settlement data is calculated. Total system average HH demand for weekday settlement period 35 for the corresponding month in the previous year is compared to total system HH demand at Triad in that year and a percentage difference is calculated. This percentage is then applied to the User's average HH demand for weekday settlement period 35 over the last month to derive a forecast of the User's HH demand at Triad for this Financial Year.

**Formatted:** Indent: Left: 2.87 cm, Numbered + Level: 1 + Numbering Style: i, ii, iii, ... + Start at: 3 + Alignment: Left + Aligned at: 0 cm + Tab after: 1 cm + Indent at: 1 cm, Tabs: 2.62 cm, List tab + Not at 1 cm + 1.27 cm

iv) The User's non half-hourly metered (NHH) energy consumption over the period 16:00 hrs to 19:00 hrs every day over the last complete month for which The Company has settlement data is noted. Total system NHH energy consumption over the corresponding month in the previous year is compared to total system NHH energy consumption over the remaining months of that Financial Year and a percentage difference is calculated. This percentage is then applied to the User's NHH energy consumption over the month described above, and all NHH energy consumption in previous months is added, in order to derive a forecast of the User's NHH metered energy consumption for this Financial Year.

**Formatted:** Indent: Left: 2.87 cm, Numbered + Level: 1 + Numbering Style: i, ii, iii, ... + Start at: 3 + Alignment: Left + Aligned at: 0 cm + Tab after: 1 cm + Indent at: 1 cm, Tabs: 2.62 cm, List tab + Not at 1 cm + 1.27 cm

14.17.18 ~~14.28~~ Determination of The Company's Forecast for Demand Charge Purposes illustrates how the demand forecast will be calculated by The Company.

**Deleted:** 7

## Reconciliation of Demand Charges

14.17.19 The reconciliation process is set out in the CUSC. The demand reconciliation process compares the monthly charges paid by Users against actual outturn charges. Due to the Settlements process, reconciliation of demand charges is carried out in two stages; initial reconciliation and final reconciliation.

### Initial Reconciliation of demand charges

14.17.20 The initial reconciliation process compares Users' demand forecasts and corresponding monthly charges paid over the year against actual outturn data (using latest Settlement data available at the time) and corresponding charges. Initial reconciliation is carried out in two parts; Initial Reconciliation Part 1 deals with the reconciliation of half-hourly metered demand charges and Initial Reconciliation Part 2 deals with the reconciliation of non-half-hourly metered demand charges.

### Initial Reconciliation Part 1– Half-hourly metered demand

14.17.21 The Company will identify the periods forming the Triad once it has received Central Volume Allocation data from the Settlement Administration Agent for all days up to and including the last day of February. Once The Company has notified Users of the periods forming the Triad they will not be changed even if disputes are subsequently resolved which would change the periods forming the Triad.

14.17.22 Initial outturn charges for half-hourly metered demand will be determined using the latest available data of actual average Triad demand (kW) multiplied by the zonal demand tariff(s) (£/kW) applicable to the months concerned for each zone for that Financial Year. These actual values are then reconciled against the monthly charges paid in respect of half-hourly demand.

### Initial Reconciliation Part 2 – Non-half-hourly metered demand

14.17.23 Actual payments for non-half-hourly metered demand will be determined using the latest available actual energy consumption data (kWh) for the period 16:00 hrs to 19:00 hrs inclusive (i.e. settlement periods 33 to 38) over the year multiplied by the energy consumption tariff(s) (p/kWh) applicable to the months concerned for each zone. These actual values are then reconciled against the monthly charges paid in respect of non-half-hourly energy consumption.

### Final Reconciliation of demand charges

14.17.24 The final reconciliation process compares Users' charges (as calculated during the initial reconciliation process using the latest available data) against final outturn demand charges (based on final settlement data).

14.17.25 Final actual charges will be determined using the final demand reconciliation data taken from the Final Reconciliation Settlement Run or the Final Reconciliation Volume Allocation Run.

### Reconciliation of manifest errors

14.17.26 In the event that a manifest error, or multiple errors in the calculation of TNUoS tariffs results in a material discrepancy in a Users TNUoS tariff, the reconciliation process for all Users qualifying under Section 14.17.28 will be in accordance with Sections 14.17.20 to 14.17.25. The reconciliation process shall be carried out using recalculated TNUoS tariffs. Where such reconciliation is not practicable, a post-year reconciliation will be undertaken in the form of a one-off payment.

14.17.27 A manifest error shall be defined as any of the following:

- a) an error in the transfer of relevant data between the Transmission Licensees or Distribution Network Operators;
- b) an error in the population of the Transport Model with relevant data;
- c) an error in the function of the Transport Model; or
- d) an error in the inputs or function of the Tariff Model.

14.17.28 A manifest error shall be considered material in the event that such an error or, the net effect of multiple errors, has an impact of the lesser of either:

- a) an error in a User's TNUoS tariff of at least +/-£0.50/kWh; or
- b) an error in a User's TNUoS tariff which results in an error in the annual TNUoS charge of a User in excess of +/-£250,000.

14.17.29 A manifest error shall only be reconciled if it has been identified within the charging year for which the error has an effect. Errors identified outside of this period will not be eligible for reconciliation retrospectively.

### Further Information

14.17.30 ~~14.25~~ Reconciliation of Demand Related Transmission Network Use of System Charges of this statement illustrates how the monthly charges are reconciled against the actual values for demand and consumption for half-hourly and non-half-hourly metered demand respectively.

Deleted: 4

14.17.31 **The Statement of Use of System Charges** contains the £/kW zonal demand tariffs, and the p/kWh energy consumption tariffs for the current Financial Year.

14.17.32 14.27. Transmission Network Use of System Charging Flowcharts of this statement contains flowcharts demonstrating the calculation of these charges for those parties liable.

Deleted: 6



## 14.18 Generation charges

### Parties Liable for Generation Charges

14.18.1 The following CUSC parties shall be liable for generation charges:

- i) Parties of Generators that have a Bilateral Connection Agreement with The Company.
- ii) Parties of Licensable Generation that have a Bilateral Embedded Generation Agreement with The Company.

14.18.2 14.26 Classification of parties for charging purposes provides an illustration of how a party is classified in the context of Use of System charging and refers to the relevant paragraphs most pertinent to each party.

### Structure of Generation Charges

14.18.3 Generation Tariffs are comprised of Wider and Local Tariffs. The Wider Tariff is comprised of (i) a Peak Security element, (ii) a Year Round Not-Shared element, (iii) Year Round Shared element and (iv) a residual element. The Peak Security element of the Wider Tariff is not applicable for intermittent generators as the PS flag is set to zero.

14.18.4 The Local Tariff contains a substation element and may also contain a circuit element. Specifically, all transmission connected generation will be liable to pay a local substation charge, with some of these also being liable to pay a local circuit charge. For the avoidance of doubt, embedded generation has a zero local tariff.

14.18.5 The intention of the charging rules is to charge the same physical entity only once.

14.18.6 The basis of the generation charge for Power Stations is the Chargeable Capacity and the short-term chargeable capacity (as defined below for positive and negative charging zones).

14.18.7 If there is a single set of Wider and Local generation tariffs within a charging year, the Chargeable Capacity is multiplied by the relevant generation tariff to calculate the annual liability of a generator.

$$\text{Local Annual Liability} = \text{Chargeable Capacity} \times \text{Local Tariff}$$

The Wider Tariff is broken down into four components as described in 14.18.3. The breakdown of the Wider Charge for Conventional and Intermittent Power Stations are given below:

Conventional -

$$\text{Wider Annual Liability} = \text{Chargeable Capacity} \times (\text{PS Tariff} + \text{YRNS Tariff} + (\text{YRS Tariff} \times \text{ALF})) + \text{Residual Tariff}$$

Intermittent -

$$\text{Wider Annual Liability} = \text{Chargeable Capacity} \times (\text{YRNS Tariff} + (\text{YRS Tariff} \times \text{ALF})) + \text{Residual Tariff}$$

Where:

PS Tariff = Wider Peak Security Tariff

YRNS Tariff = Wider Year Round Not-Shared Tariff

**Formatted:** Indent: Left: 2.87 cm, Hanging: 1.27 cm, Numbered + Level: 1 + Numbering Style: i, ii, iii, ... + Start at: 1 + Alignment: Left + Aligned at: 0 cm + Tab after: 1.27 cm + Indent at: 0.63 cm, Tabs: 4.14 cm, List tab + Not at 1.27 cm

**Formatted:** Indent: Left: 2.87 cm, Hanging: 1.27 cm, Numbered + Level: 1 + Numbering Style: i, ii, iii, ... + Start at: 1 + Alignment: Left + Aligned at: 0 cm + Tab after: 1.27 cm + Indent at: 0.63 cm, Tabs: 4.14 cm, List tab + Not at 1.27 cm

**Deleted:** 5

**Deleted:** Charges

**Deleted:** Charges,

**Formatted:** Font: 11 pt, Highlight

**Deleted:** latter of which

**Formatted:** Font: 11 pt, Highlight

**Formatted:** Highlight

**Formatted:** Highlight

**Formatted:** Font: 11 pt, Highlight

**Formatted:** Font: 11 pt, Highlight

**Formatted:** Highlight

**Formatted:** Highlight

**Formatted:** Font: 11 pt, Highlight

**Formatted:** Highlight

**Formatted:** Font: 11 pt, Highlight

**Formatted:** Font: 11 pt, Highlight

**Formatted:** Highlight

**YRS Tariff = Wider Year Round Shared Tariff**

14.18.8 If multiple sets of Wider and Local generation tariffs are applicable within a single charging year, the Chargeable Capacity is multiplied by the relevant tariffs pro rated over the entire charging year, across the months that they are applicable for.

**Formatted:** Font: 11 pt, Highlight  
**Formatted:** Indent: Left: 2.87 cm

$$\text{Annual Liability} = \left( \frac{a \times \text{Liability 1} + b \times \text{Liability 2}}{12} \right)$$

where:

Liability 1 = Original annual liability,

Liability 2 = Revised annual liability,

a = Number of months over which the original Liability is applicable,

b = Number of months over which the revised Liability is applicable.

**Deleted:** Tariff  
**Deleted:** tariff  
**Deleted:** Tariff  
**Deleted:** tariff  
**Deleted:** tariff  
**Deleted:** tariff

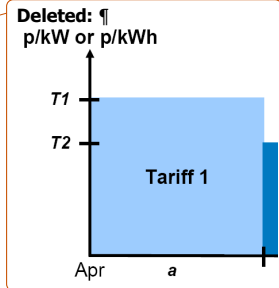
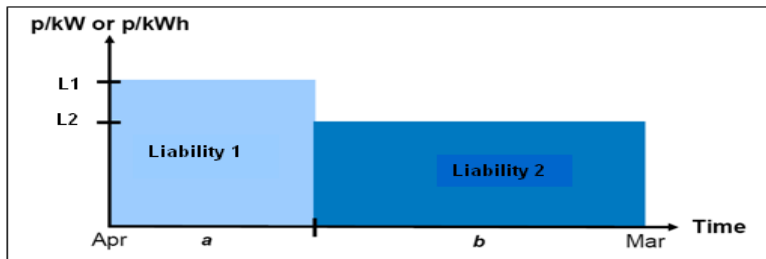

14.18.9 For the avoidance of doubt if there are multiple sets of Wider and Local generation tariffs applicable within a single charging year and a tariff changes from being positive to negative or vice versa, the Chargeable Capacity for the entire charging year will be determined based on the net position of the pro rated tariffs for each affected generator.

**Basis of Wider Generation Charges**

**Generation with positive wider tariffs**

14.18.10 The Chargeable Capacity for Power Stations with positive wider generation tariffs is the highest Transmission Entry Capacity (TEC) applicable to that Power Station for that Financial Year. A Power Station should not exceed its TEC as to do so would be in breach of the CUSC, except where it is entitled to do so under the specific circumstances laid out in the CUSC (e.g. where a User has been granted Short Term Transmission Entry Capacity, STTEC). For the avoidance of doubt, TNUoS Charges will be determined on the TEC held by a User as specified within a relevant bilateral agreement regardless of whether or not it enters into a temporary TEC Exchange (as defined in the CUSC).

14.18.11 The short-term chargeable capacity for Power Stations situated with positive generation tariffs is any approved STTEC or LDTEC applicable to that Power Station during a valid STTEC Period or LDTEC Period, as appropriate.

14.18.12 For Power Stations, the short term chargeable capacity for LDTEC with positive generation tariffs referred to in Paragraph 14.18.11, will be the capacity purchased

**Deleted:** 14.18.1011

either on a profiled firm<sup>2</sup> or indicative<sup>3</sup> basis and shall be assessed according to the capacity purchased on a weekly basis. The short-term chargeable capacity for LDTEC in any week may comprise of a number of increments, which shall be determined by considering LDTEC purchased previously in the Financial Year (whether or not in the same LDTEC Period). For example, if in a given week the LDTEC is 200MW but in a previous week the LDTEC had been 150MW, the short-term chargeable capacity in the latter week would comprise of two increments: one of 150MW and a second of 50MW. Further examples are provided in 14.16.6.

### Generation with negative wider tariffs

14.18.13 The Chargeable Capacity for Power Stations with negative wider generation tariffs is the average of the capped metered volumes during the three settlement periods described in [14.18.14](#) below, for the Power Station (i.e. the sum of the metered volume of each BM Unit associated with Power Station in Appendix C of its Bilateral Agreement). A Power Station should not exceed its TEC as to do so would be in breach of the CUSC, except where it is entitled to do so under the specific circumstances laid out in the CUSC (e.g. where a User has been granted Short Term Transmission Entry Capacity). If TEC is exceeded, the metered volumes would each be capped by the TEC for the Power Station applicable for that Financial Year. For the avoidance of doubt, TNUoS Charges will be determined on the TEC held by a User as specified within a relevant bilateral agreement regardless of whether or not it enters into a temporary TEC Exchange (as defined in the CUSC).

Deleted: 14.18.1314

14.18.14 The three settlement periods are those of the highest metered volumes for the Power Station and the two half hour settlement periods of the next highest metered volumes which are separated from the highest metered volumes and each other by at least 10 Clear Days, between November and February of the relevant Financial Year inclusive. These settlement periods do not have to coincide with the Triad.

#### Example

If the highest TEC for a Power Station were **250MW** and the highest metered volumes and resulting capped metered volumes were as follows:

Date	19/11/08	13/12/08	06/02/09
Highest Metered Volume in month (MW)	<b>245.5</b>	<b>250.3</b>	<b>251.4</b>
Capped Metered Volume (MW)	<b>245.5</b>	<b>250.0</b>	<b>250.0</b>

Then, the chargeable Capacity for the Power Station would be:

$$\left( \frac{245.5 + 250 + 250}{3} \right) = \mathbf{248.5 \text{ MW}}$$

Note that in the example above, the Generator has exceeded its TEC on 13 December 2007 and 6 February 2008 and would therefore be in breach of the CUSC unless the

<sup>2</sup> where an LDTEC Block Offer has been accepted (Profiled Block LDTEC) and a firm profile of capacity has been purchased.

<sup>3</sup> where an LDTEC Indicative Block Offer has been accepted (Indicative Profiled Block LDTEC) and a right to future additional capacity up to a requested level has been purchased, the availability of which will be notified on a weekly basis in accordance with the CUSC.

generator had an approved STTEC or LDTEC value. (The STTEC and LDTEC charge for negative zones is currently set at zero).

14.18.15 The short-term chargeable capacity for Power Stations with negative generation tariffs is any approved STTEC or LDTEC applicable to that Power Station during a valid STTEC Period or LDTEC Period, as applicable.

14.18.16 For Power Stations with negative generation tariffs, the short-term chargeable capacity for LDTEC referred to in Paragraph 14.18.15 will be the capacity purchased either on a profiled firm or indicative basis and shall be assessed according to the capacity purchased on a weekly basis. The short-term chargeable capacity for LDTEC in any week may comprise of a number of increments, which shall be determined by considering LDTEC purchased previously in the Financial Year (whether or not in the same LDTEC Period). For example, if in a given week the LDTEC is 200MW but in a previous week the LDTEC had been 150MW, the short-term chargeable capacity in the latter week would comprise of two increments: one of 150MW and a second at 50MW.

Deleted: 14

14.18.17 As noted above, a negative LDTEC tariff in negative generation charging zones is set to zero. Accordingly no payments will be made for use of LDTEC (in any of its forms) in these zones.

### Basis of Local Generation Charges

14.18.18 The Chargeable Capacity for Power Stations will be the same as that used for wider generation charges, except that each component of the local tariff shall be considered separately as to whether it is a positive or negative tariff component. This means that where a local circuit tariff is negative, the final charging liability for this element will be based on actual metered output as described in Paragraph 14.18.12.

### Small Generators Charges

14.18.19 Eligible small generators' tariffs are subject to a discount of a designated sum defined by Licence Condition C13 as 25% of the combined residual charge for generation and demand. The calculation for small generators charges is not part of the methodology however, for information the designated sum is included in **The Statement of Use of System Charges**.

### Monthly Charges

14.18.20 Initial Transmission Network Use of System Generation Charges for each Financial Year will be based on the Power Station Transmission Entry Capacity (TEC) for each User as set out in their Bilateral Agreement. The charge is calculated as above. This annual TNUoS generation charge is split evenly over the months remaining in the year. For positive final generation tariffs, if TEC increases during the charging year, the party will be liable for the additional charge incurred for the **full** year, which will be recovered uniformly across the remaining chargeable months in the relevant charging year (subject to Paragraph 14.18.21 below). An increase in monthly charges reflecting an increase in TEC during the charging year will result in interest being charged on the differential sum of the increased and previous TEC charge. The months liable for interest will be those preceding the TEC increase from April in year t. For negative final generation tariff, any increase in TEC during the year will lead to a recalculation of the monthly charges for the remaining chargeable months of the relevant charging year. However, as TEC decreases do not become effective until the start of the financial year following approval, no recalculation is necessary in these cases. As a result, if TEC increases, monthly payments to the generator will increase accordingly.

Deleted: ..2

Deleted: 0

14.18.21 The provisions described above for increases in TEC during the charging year shall not apply where the LDTEC (in any of its forms) has been approved for use before the TEC is available, which will typically mean the LDTEC has been approved after the TEC increase has been approved. In such instances, the party shall commence payments for TEC during the LDTEC Period for LDTEC purchased up to the future level of TEC and LDTEC Charges will only apply to LDTEC that is incremental to the TEC increase. For the avoidance of doubt, where TEC has been approved after LDTEC in a given year, these provisions shall not apply and the LDTEC shall be considered additional to the TEC and charged accordingly.

### Ad hoc Charges

14.18.22 For each STTEC period successfully applied for, a charge will be calculated by multiplying the STTEC by the tariff calculated in accordance with Paragraph 14.16.3. The Company will invoice Users for the STTEC charge once the application for STTEC is approved.

Deleted: .

14.18.23 For Power Stations utilising LDTEC (in any of its forms) the LDTEC Charge for each LDTEC Period is the sum of the charging liabilities associated with each incremental level of short term chargeable capacity provided by LDTEC within the LDTEC Period (assessed on a weekly basis). The charging liability for a given incremental level of short term chargeable capacity is the sum of:

- i) the product of the higher tariff rate (calculated in accordance with Paragraph 14.16.6) and capacity purchased at this increment for the first 17 weeks in a Financial Year (whether consecutive or not); and
- ii) the product of the lower tariff rate (calculated in accordance with Paragraph 14.16.6) and capacity purchased at this increment in any additional weeks within the same Financial Year (whether consecutive or not).

14.18.24 For each LDTEC Period successfully applied for, the LDTEC Charge will be split evenly over the relevant LDTEC Period and charged on a monthly basis. LDTEC charges will apply to both LDTEC (in any of its forms) and Temporary Received TEC held by a User. For the avoidance of doubt, the charging methodology will not differentiate between access rights provided to a generator by LDTEC or through Temporary Received TEC obtained through a Temporary TEC Exchange (as defined in the CUSC).

### Example

The diagrams below show two cases where LDTEC has been purchased: in Case A, two LDTEC Periods have been purchased; and in Case B one LDTEC Period has been purchased. The total capacity purchased in both cases is the same. The top diagrams illustrate the capacity purchased, while lower diagrams illustrate the incremental levels of short term chargeable capacities of LDTEC and the tariff rate that would apply to that capacity.

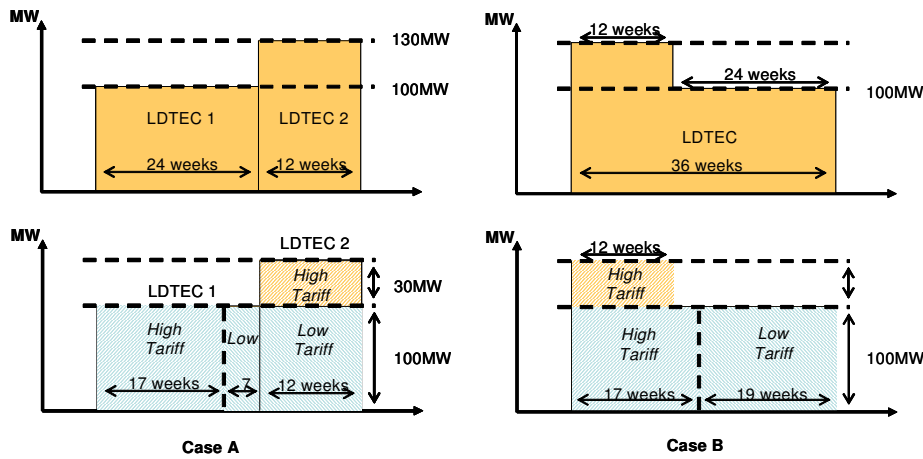

In both cases, the total amount charged for the LDTEC would be the same:

- Capacity charges at the higher tariff rate:
  - 17 weeks at the 100MW increment
  - 12 weeks at the 30MW increment
- Capacity charges at the lower tariff rate:
  - 19 weeks at the 100MW increment

**Formatted:** Indent: Left: 0 cm, Hanging: 0.44 cm, Bulleted + Level: 1 + Aligned at: 0 cm + Tab after: 0.63 cm + Indent at: 0.63 cm, Tabs: 0.44 cm, List tab + Not at 0.63 cm + 1.27 cm

**Formatted:** Indent: Left: 0 cm, Hanging: 0.47 cm, Bulleted + Level: 1 + Aligned at: 0 cm + Tab after: 0.63 cm + Indent at: 0.63 cm, Tabs: 0.47 cm, List tab + Not at 0.63 cm + 1.27 cm

### Embedded Transmission Use of System Charges “ETUoS”

- 14.18.25 The ETUoS charges are a component of Use of System charges levied on offshore generators whose offshore transmission connection is embedded in an onshore distribution network. The charge relates to the provision and use of the onshore distribution network.
- 14.18.26 The main purpose of ETUoS charges is to pass through the charges that are levied by the DNO on the NETSO to the offshore generator(s). This charge reflects the charges levied by the DNO for the costs of any works on and use of the DNO network in accordance with the DNO’s charging statements and will include, but is not limited to, upfront charges and capital contributions in respect of any works as well as the ongoing and annual Use of System charges for generation connected to the distribution network.
- 14.18.27 In the case of some relevant transitional offshore generation projects, ETUoS will also be used to pass through historic DNO capital contributions forming part of the Offshore Transmission Owner tender revenue stream.
- 14.18.28 The specific nature of the ETUoS charge and the payment profile for these will depend upon the charging arrangements of the relevant DNO and reference should be made to the relevant DNO’s charging statement. In terms of applicable transitional offshore generation projects the ETUoS payment profile will be consistent with the recovery of the Offshore Transmission Owner revenue stream.
- 14.18.29 Where a DNO’s charge relates to more than one offshore generator, the related ETUoS charge will represent a straight pass through of the distribution charge specific to each relevant offshore generator. Where specific information is not available, charges will be pro-rated based on the TEC of the relevant offshore generators connected to that offshore network.
- 14.18.30 Invoices for ETUoS charges shall be levied by the NETSO on the offshore generator as soon as reasonably practicable after invoices have been received by the NETSO for payment such that the NETSO can meet its payment obligations to the DNO. The

initial payments and payment dates will be outlined in a User's Construction Agreement and/or Bilateral Agreement.

14.18.31 As the ETUoS charges reflect the DNO charges to the NETSO, such charges will be subject to variation when varied by the DNO. Where the User disputes regarding the ETUoS charge please note that this will result in a dispute between the NETSO and DNO under the DCUSA.

### Reconciliation of Generation Charges

14.18.32 The reconciliation process is set out in the CUSC and in line with the principles set out above.

14.18.33 In the event of a manifest error in the calculation of TNUoS charges which results in a material discrepancy in a User's TNUoS charge as defined in Sections 14.17.27 to 14.17.29, the generation charges of Users qualifying under Section 14.17.28 will be reconciled in line with [14.18.20](#) and [14.18.25](#) using the recalculated tariffs.

Deleted: 14.18.1920

Deleted: 14.18.2425

### Further Information

14.18.34 **The Statement of Use of System Charges** contains the £/kW generation zonal tariffs for the current Financial Year.

## 14.19 Data Requirements

### Data Required for Charge Setting

- 14.19.1 Users who are Generators or Interconnector Asset Owners provide to The Company a forecast for the following Financial Year of the highest Transmission Entry Capacity (TEC) applicable to each Power Station or Interconnector for that Financial Year. For Financial Year 2008/9 Scottish Generators or Interconnector Asset Owners provide to The Company a forecast of the equivalent highest 'export' capacity figure. This data is required by The Company as the basis for setting TNUoS tariffs. The Company may request these forecasts in the November prior to the Financial Year to which they relate, in accordance with the CUSC. Additionally users who are Generators provide to The Company details of their generation plant type.
- 14.19.2 Users who are owners or operators of a User System (e.g. Distribution companies) provide a forecast for the following Financial Year of the Natural Demand attributable to each Grid Supply Point equal to the forecasts of Natural Demand under both Annual Average Cold Spell (ACS) Conditions and a forecast of the average metered Demand attributable to such Grid Supply Point for the National Grid Triad. This data is published in table 2.4 of the Seven Year Statement and is compiled from week 24 data submitted in accordance with the Grid Code.
- 14.19.3 For the following Financial Year, The Company shall use these forecasts as the basis of Transmission Network Use of System charges for such Financial Year. A description of how this data is incorporated is included in 14.15 Derivation of the Transmission Network Use of System Tariff.
- 14.19.4 If no data is received from the User, then The Company will use the best information available for the purposes of calculation of the TNUoS tariffs. This will normally be the forecasts provided for the previous Financial Year.

### Data Required for Calculating Users' Charges

- 14.19.5 In order for The Company to calculate Users' TNUoS charges, Users who are Suppliers shall provide to The Company forecasts of half-hourly and non-half-hourly demand in accordance with paragraph 14.17.14 and 14.17.15 and in accordance with the CUSC.



## 14.20 Applications

14.20.1 Application fees are payable in respect of applications for new Use of System agreements; modifications to existing agreements; and applications for short-term access products or services. These are based on the reasonable costs that transmission licensees incur in processing these applications.

### Applications for short-term access

14.20.2 Application fees for short-term access products or services are fixed and detailed in the **Statement of Use of System Charges**. These are non-refundable except for the following limited instances:

- Where a User (or Users) withdraw their application in accordance with any interactivity provisions that may be contained within the CUSC; or
- Where the application fee covers ongoing assessment work that is contingent on the acceptance of the offer.

14.20.3 In either case, the refunded amount will be proportional to the remaining assessment time available.

14.20.4 To ensure that application fees for short-term access are cost reflective, fees may be comprised of a number of components. For instance, the LDTEC Request Fee is comprised of a number of components and the total fee payable is the sum of those components that apply to the type(s) of LDTEC Offer(s) requested. For example:

- The LDTEC Request Fee for an LDTEC Block Offer is the basic request fee.
- The LDTEC Request Fee for an LDTEC Indicative Block Offer is the sum of the basic request fee and the additional rolling assessment fee.
- The LDTEC Request Fee payable for a combined LDTEC Block Offer and LDTEC Indicative Block Offer is the sum of the basic request fee, the additional rolling assessment fee, and the additional combined application fee.

**Formatted:** Indent: Left: 2.87 cm, Hanging: 0.75 cm, Bulleted + Level: 1 + Aligned at: 0 cm + Tab after: 0.63 cm + Indent at: 0.63 cm, Tabs: 3.62 cm, List tab + Not at 0.63 cm + 1.27 cm

**Formatted:** Indent: Left: 2.87 cm, Hanging: 0.75 cm, Bulleted + Level: 1 + Aligned at: 0 cm + Tab after: 0.63 cm + Indent at: 0.63 cm, Tabs: 3.62 cm, List tab + Not at 0.63 cm + 1.27 cm

**Formatted:** Indent: Left: 2.87 cm, Hanging: 0.75 cm, Bulleted + Level: 1 + Aligned at: 0 cm + Tab after: 0.63 cm + Indent at: 0.63 cm, Tabs: 3.62 cm, List tab + Not at 0.63 cm + 1.27 cm

### Applications for new or modified existing Use of System Agreements

14.20.5 Users can opt to pay a fixed price application fee in respect of their application or pay the actual costs incurred. The fixed price fees for applications are detailed in the **Statement of Use of System Charges**.

14.20.6 If a User chooses not to pay the fixed fee, the application fee will be based on an advance of transmission licensees' Engineering and out-of pocket expenses and will vary according to the size of the scheme and the amount of work involved. Once the associated offer has been signed or lapsed, a reconciliation will be undertaken. Where actual expenses exceed the advance, The Company will issue an invoice for the excess. Conversely, where The Company does not use the whole of the advance, the balance will be returned to the User.

14.20.7 The Company will refund the first application fee paid (the fixed fee or the amount post-reconciliation) and consent payments made under the Construction Agreement for new or modified existing agreements. The refund shall be made either on commissioning or against the charges payable in the first three years of the new or modified agreement. The refund will be net of external costs.

- 14.20.8 The Company will not refund application fees for applications to modify a new agreement or modified existing agreement at the User's request before any charges become payable. For example, The Company will not refund an application fee to delay the provision of a new connection if this is made prior to charges becoming payable.

### 14.21 Transport Model Example

For the purposes of the DCLF Transport algorithm, it has been assumed that the value of circuit impedance is equal to the value of circuit reactance.

Consider the following 3-node network, where generation at node A is intermittent and generation at node B is conventional:

Deleted: ¶

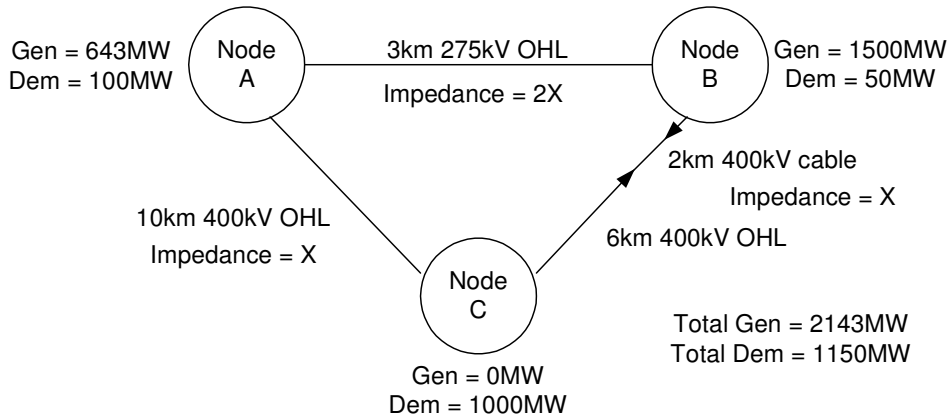

→ Denotes cable

For both Peak Security and Year Round generation backgrounds, the nodal generation is scaled according to the relevant Scaling Factors as set out in the Security Standard, such that total system generation equals total system demand.

Deleted: The first step is to match total demand

Deleted: total

Deleted: by scaling uniformly

Deleted: down

Deleted:

**Peak Security background:**

A fixed scaling factor of 0% is applied to intermittent generation at node A and a variable scaling factor is applied to the conventional generation at node B so that the total generation is equal to the total demand.

Node A Generation =  $0 * 643MW = 0MW$

Deleted:  $1150/1495 * 650MW = 500MW$ ¶

Node B Generation =  $1150/1500 * 1500MW = 1150MW$

Deleted:  $1495 * 845MW = 650MW$ ¶

This gives the following balanced system, where the actual generation after the application of scaling factors is shown:

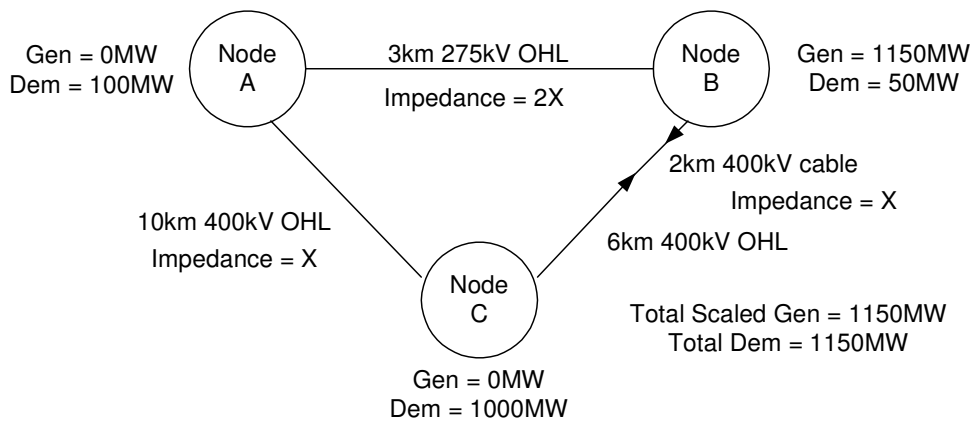

Assuming Node A is the reference node<sup>†</sup>, each 400kV circuit has impedance X, the 275kV circuit has impedance 2X, the 400kV cable circuit expansion factor is 10 and the 275kV overhead line circuit expansion factor is 2, the DCLF transport algorithm calculates the base case power flows for Peak Security background as follows:

Deleted: ¶  
¶  
¶  
¶

Formatted: Font: Times New Roman, 12 pt

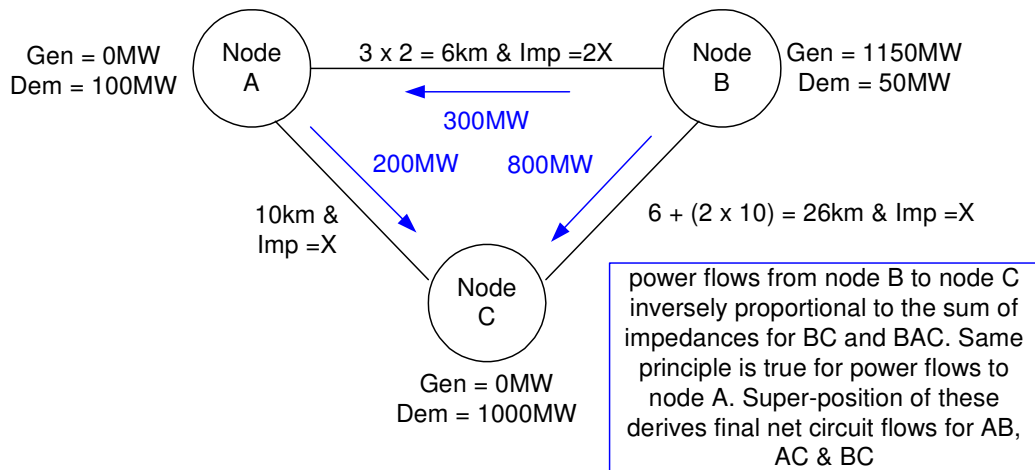

power flows from node B to node C inversely proportional to the sum of impedances for BC and BAC. Same principle is true for power flows to node A. Super-position of these derives final net circuit flows for AB, AC & BC

Node B exports, whilst Nodes A and C import. Hence the DCLF algorithm derives flows to deliver export power from Node B to meet import needs at Nodes A and C.

Step 1: Net export from Node B to Node A is 100MW; both routes BA and BC-CA have impedance 2X; hence 50MW would flow down both routes.

Step 2: Net export from Node B to Node C is 1000MW; route BC has impedance X and route BA-AC has impedance 3X; hence 750MW would flow down BC and 250MW along BA-AC

Step 3: Using super-position to add the flows derived in Steps 1 and 2 derives the following;

Flow AC	=	-50MW + 250MW	=	200MW
Flow AB	=	-50MW - 250MW	=	-300MW
Flow BC	=	50MW + 750MW	=	800MW

† For simplicity, fixed reference node has been used instead of a distributed reference node.

**Year Round background:**

A fixed scaling factor of 70% is applied to intermittent generation at node A and a variable scaling factor is applied to the conventional generation at node B so that the total generation is equal to the total demand.

Node A Generation = 70% \* 643MW = 450MW

Node B Generation = (1150-450)/1500 \* 1500MW = 700MW

This gives the following balanced system, where the actual generation after the application of scaling factors is shown:

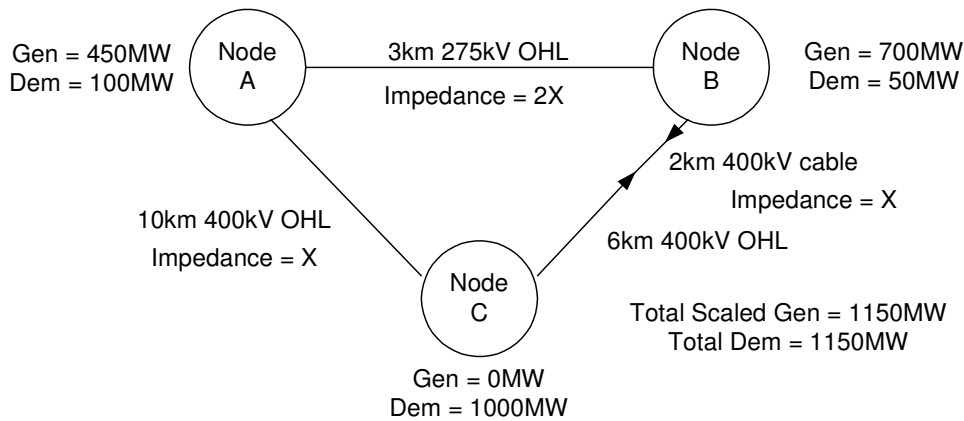

Assuming the same circuit impedances and expansion factors as used above in the Peak Security background, the DCLF transport algorithm calculates the base case power flows for Year Round background as follows:

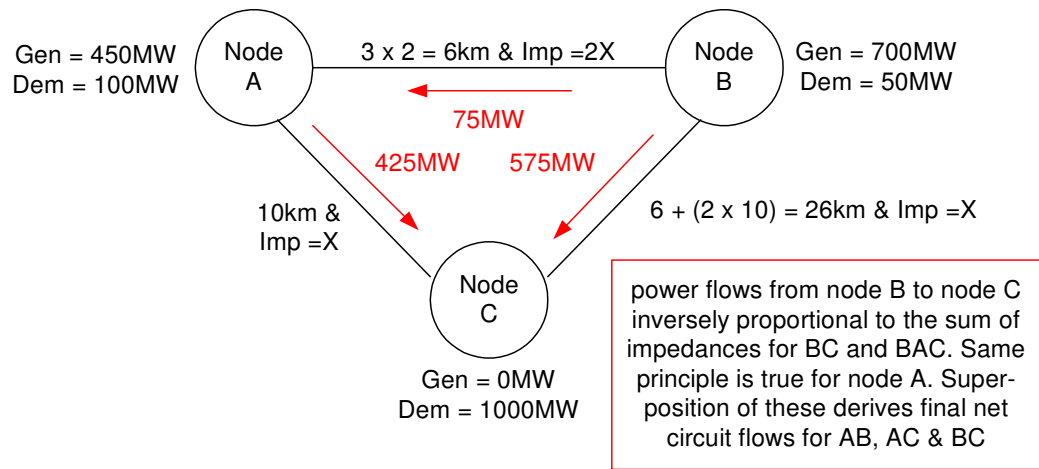

Nodes A and B export, whilst Node C imports. Hence the DCLF algorithm derives flows to deliver export power from Nodes A and B to meet import needs at Node C.

Step 1: Net export from Node A is 350MW; route AC has impedance X and route AB-BC has impedance 3X; hence 262.5MW would flow down AC and 87.5MW along AB-BC.

**Formatted:** Font: Arial

**Formatted:** Body Text 2, Justified

**Deleted:** 400MW

**Deleted:** 300MW

**Deleted:** 100MW

Step 2: Net export from Node B is 650MW; route BC has impedance X and route BA-AC has impedance 3X; hence 487.5MW would flow down BC and 162.5MW along BA-AC

~~Deleted: 600MW~~

~~Deleted: 450MW~~

~~Deleted: 150MW~~

Step 3: Using super-position to add the flows derived in Steps 1 and 2 derives the following;

Flow AC =  $\underline{262.5MW + 162.5MW} = \underline{425MW}$   
 Flow AB =  $\underline{87.5MW - 162.5MW} = \underline{-75MW}$   
 Flow BC =  $\underline{87.5MW + 487.5MW} = \underline{575MW}$

~~Deleted: 300MW + 150MW = . 450MW¶~~

~~Deleted: 100MW - 150MW = . -50MW¶~~

~~Deleted: 100MW + 450MW = . 550MW¶~~

Then, based on the background giving rise to highest flow, each circuit is tagged as either Peak Security or Year Round.

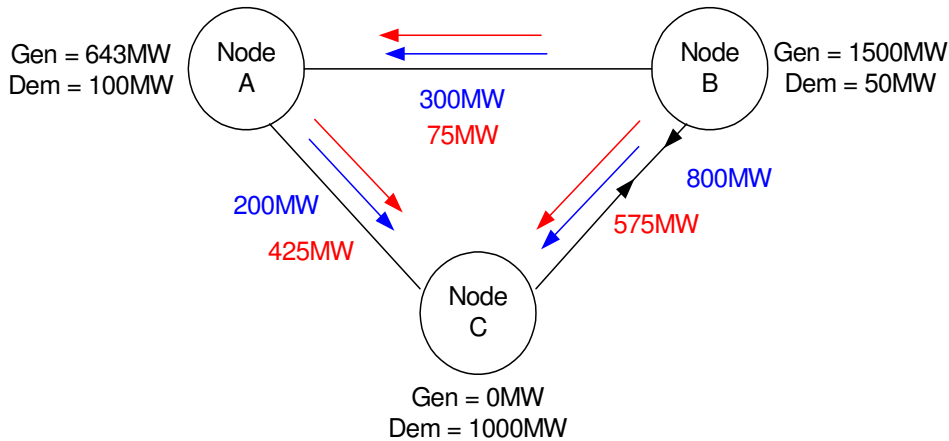

Therefore, circuits AB and BC are tagged as Peak Security and AC is tagged as Year Round.

Total Peak Security cost =  $(300 \times 6) + (800 \times 26) = 22,600$  MWkm (base case)

~~Formatted: Font: 11 pt, Italic~~

~~Formatted: Font: 11 pt~~

~~Formatted: Font: 11 pt~~

~~Deleted:  $450 \times 10) + (50 \times$~~

~~Formatted: Font: 11 pt~~

~~Deleted: 550 x~~

~~Formatted: Font: 11 pt~~

~~Deleted: 19,100~~

~~Formatted: Font: 11 pt~~

~~Formatted: Font: 11 pt~~

~~Formatted: Font: Italic~~

~~Deleted: in cost~~

~~Deleted: . This is demonstrated as follows:¶~~

Total Year Round cost =  $425 \times 10 = 4,250$  MWkm (base case)

We then 'inject' 1MW of generation at each node with a corresponding 1MW offtake (demand) at the reference node and recalculate the total Peak Security MWkm cost and Year Round MWkm cost (noting that each circuit is only in one background). The difference from the base case for Peak Security and Year Round costs is the marginal km or shadow cost for Peak Security and Year Round networks respectively. The size and direction of the incremental MW is shown below along with the resultant when superimposed on the relevant base case flow (i.e. higher of the Peak Security and Year Round) depicted in brackets:.

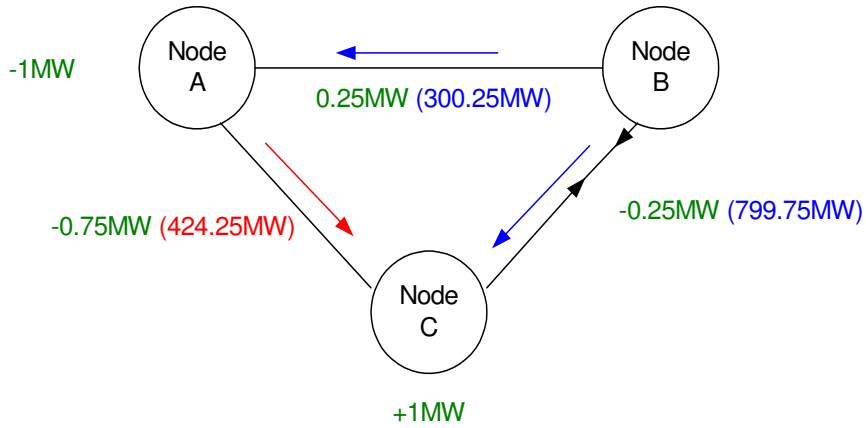

To calculate the relevant Peak Security and Year Round marginal km for node C:

Total Peak Security Cost =  $(300.25 \times 6) + (799.75 \times 26) = 22,595 \text{ MWkm}$

Total Year Round Cost =  $424.25 \times 10 = 4,242.5 \text{ MWkm}$

Marginal Peak Security cost = Incremental total Peak Security cost – Base case total Peak Security cost  
 $= 22595 - 22600 = -5 \text{ MWkm}$

Marginal Year Round cost = Incremental total Year Round cost – Base case total Year Round cost  
 $= 4242.5 - 4250 = -7.5 \text{ MWkm}$

Thus, the overall cost has reduced by 5 for Peak Security (i.e. the Peak Security marginal km = -5) and by 7.5 for Year Round (i.e. the Year Round marginal km = -7.5)

- Deleted: ¶
- Deleted: at
- Deleted:  $449.25 \times 10) + (50$
- Deleted: 549
- Deleted: 19,087

- Deleted: 12.
- Deleted: 12.5).¶

## 14.22 Illustrative Calculation of Boundary Sharing Factors (BSFs) and Shared / Not-Shared incremental km

The following illustrative example shows how the boundary sharing factors and shared / not-shared incremental km are calculated for the transmission system described in the table below.

Generation Charging Zone	A	B	C	D
Zonal MWkm	450	350	150	100

The diagram below shows the expanded connectivity of this transmission system.

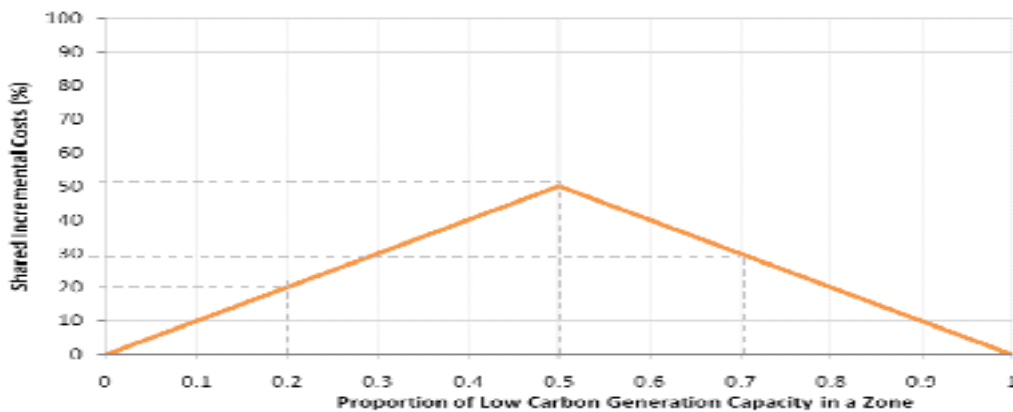
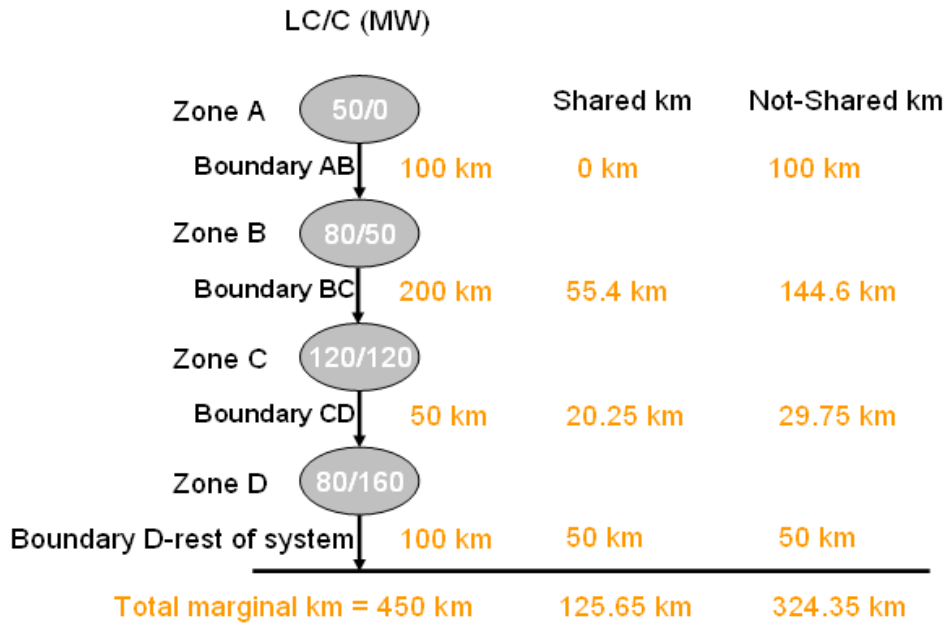

- Formatted: Font: Arial Bold, 15 pt, Bold, Font color: Dark Blue, Highlight
- Formatted: Font: Arial Bold, 15 pt, Bold, Font color: Dark Blue, Highlight
- Formatted: Highlight
- Formatted: Font: 12 pt, Highlight
- Formatted: Font: 12 pt, Highlight
- Formatted: Highlight
- Formatted: Highlight
- Formatted: Highlight
- Formatted: Font: 11 pt, Highlight
- Formatted: Highlight
- Formatted: Font: 11 pt, Highlight
- Formatted: Highlight
- Formatted: Font: 11 pt, Highlight
- Formatted: Highlight
- Formatted: Font: 11 pt, Highlight
- Formatted: Highlight
- Formatted: Highlight
- Formatted: Font: 11 pt, Highlight
- Formatted: Highlight
- Formatted: Highlight
- Formatted: Highlight
- Formatted: Highlight
- Formatted: Highlight
- Formatted: Highlight
- Formatted: Highlight
- Formatted: Highlight
- Formatted: Highlight
- Formatted: Highlight
- Formatted: Highlight
- Formatted: Highlight
- Formatted: Highlight
- Deleted: 14.22 Sharing of Year Round Marginal km costs
- Formatted: Font: 15 pt, Highlight
- Formatted: Highlight
- Formatted: Normal
- Formatted: Font: Bold, Highlight
- Formatted



The above figure illustrates how the Year Round marginal km are split into Shared and Not-Shared marginal km.

(a) For Boundary AB (where 50MW of the generation is Low Carbon (LC) and 0MW of the generation is Carbon (C) and Year Round boundary marginal km = 100km) -

The Boundary Sharing Factor (BSF) is calculated using the following formula -

$$BSF = \text{Minimum} \left( \frac{LC}{LC+C}, \frac{C}{LC+C} \right) = \text{Minimum} \left( \frac{100}{100}, \frac{0}{100} \right) = 0.0 \text{ (0.0\%)}$$

Year Round Shared marginal km = 0.0 \* 100km = 0 km

Year Round Not-Shared marginal km = (100 - 0)km = 100 km

(b) For Boundary BC (where 130MW of the generation is Low Carbon (LC) and 50MW of the generation is Carbon (C) and Year Round boundary marginal km = 200km) -

The BSF is calculated using the following formula -

$$BSF = \text{Minimum} \left( \frac{LC}{LC+C}, \frac{C}{LC+C} \right) = \text{Minimum} \left( \frac{(50+80)}{(50+80)+(0+50)}, \frac{(0+50)}{(50+80)+(0+50)} \right)$$

$$= \text{Minimum} \left( \frac{130}{180}, \frac{50}{180} \right) = 0.277 \text{ (27.77\%)}$$

Year Round Shared marginal km = 0.277 \* 200km = 55.4 km

Year Round Not-Shared marginal km = (200 - 55.4)km = 144.6 km

(c) For Boundary CD (where 250MW of the generation is Low Carbon (LC) and 170MW of the generation is Carbon (C) and Year Round boundary marginal km = 50km) -

The BSF is calculated using the following formula -

$$BSF = \text{Minimum} \left( \frac{LC}{LC+C}, \frac{C}{LC+C} \right)$$

$$= \text{Minimum} \left( \frac{(50+80+120)}{(50+80+120)+(0+50+120)}, \frac{(0+50+120)}{(50+80+120)+(0+50+120)} \right)$$

$$= \text{Minimum} \left( \frac{250}{420}, \frac{170}{420} \right) = 0.405 \text{ (40.5\%)}$$

Year Round Shared marginal km = 0.405 X 50km = 20.25 km

Year Round Not-Shared marginal km = (50 - 20.25)km = 29.75 km

(d) For Boundary D-rest of system (where 330MW of the generation is Low Carbon (LC) and 330MW of the generation is Carbon (C) and Year Round boundary marginal km = 100km) -

The BSF is calculated using the following formula -

Formatted	... [48]
Formatted	... [49]
Formatted	... [50]
Deleted: zonal	
Formatted	... [51]
Deleted: % of Shared	... [52]
Formatted	... [53]
Formatted	... [54]
Field Code Changed	... [55]
Formatted	... [56]
Formatted	... [57]
Deleted: therefore the	... [58]
Formatted	... [59]
Formatted	... [60]
Formatted	... [61]
Formatted	... [62]
Formatted	... [63]
Formatted	... [64]
Formatted	... [65]
Formatted	... [66]
Deleted: zonal	
Formatted	... [67]
Deleted: % of Shared	... [68]
Formatted	... [69]
Formatted	... [70]
Field Code Changed	... [71]
Formatted	... [72]
Field Code Changed	... [73]
Formatted	... [74]
Deleted: therefore the	... [75]
Formatted	... [76]
Formatted	... [77]
Formatted	... [78]
Formatted	... [79]
Formatted	... [80]
Formatted	... [81]
Deleted: zonal	
Formatted	... [82]
Deleted: % of Shared	... [83]
Formatted	... [84]
Formatted	... [85]
Field Code Changed	... [86]
Formatted	... [87]
Field Code Changed	... [88]
Formatted	... [89]
Field Code Changed	... [90]
Formatted	... [91]
Deleted: therefore the	... [92]
Formatted	... [93]
Formatted	... [94]
Formatted	... [95]
Formatted	... [96]
Formatted	... [97]
Formatted	... [98]
Deleted: zonal...	... [99]
Formatted	... [100]
	... [101]
Formatted	... [102]
Formatted	... [103]

$$BSF = \text{Minimum} \left( \frac{LC}{LC+C}, \frac{C}{LC+C} \right)$$

$$= \text{Minimum} \left( \frac{(50 + 80 + 120 + 80)}{(50 + 80 + 120 + 80) + (0 + 50 + 120 + 160)}, \frac{(0 + 50 + 120 + 160)}{(50 + 80 + 120 + 80) + (0 + 50 + 120 + 160)} \right)$$

$$= \text{Minimum} \left( \frac{330}{660}, \frac{330}{660} \right) = 0.5 \text{ (50\%)}$$

Year Round Shared marginal km = 0.5 X 100km = 50 km  
 Year Round Not-Shared marginal km = (100 - 50)km = 50 km

The shared zonal marginal km for each generation charging zone will be the sum of the relevant shared boundary marginal km as shown in the table below (assuming the node below D is the centre of the system i.e. zonal MWkm of 0). These not-shared zonal incremental km are then use to calculate wider £/kW generation tariffs.

Boundary/Zone	A	B	C	D
A-B	0			
B-C	55.4	55.4		
C-D	20.25	20.25	20.25	
D-rest of system	50	50	50	50
Shared Zonal MWkm	125.65	125.65	70.25	50
Total Zonal MWkm	450	350	150	100

The not-shared zonal marginal km for each generation charging zone will be the sum of the relevant not-shared boundary marginal km as shown in the table below (assuming the node below D is the centre of the system i.e. zonal MWkm of 0). These not-shared zonal incremental km are then use to calculate wider £/kW generation tariffs.

Boundary/Zone	A	B	C	D
A-B	100			
B-C	144.6	144.6		
C-D	29.75	29.75	29.75	
D-rest of system	50	50	50	50
Not-Shared Zonal MWkm	324.35	224.35	79.75	50
Total Zonal MWkm	450	350	150	100

- Field Code Changed ... [104]
- Formatted ... [105]
- Field Code Changed ... [106]
- Formatted ... [107]
- Formatted ... [108]
- Field Code Changed ... [109]
- Formatted ... [110]
- Deleted: therefore the ... [111]
- Formatted ... [112]
- Formatted ... [113]
- Formatted ... [114]
- Formatted ... [115]
- Formatted ... [116]
- Formatted ... [117]
- Formatted ... [118]
- Formatted ... [119]
- Formatted ... [120]
- Formatted ... [121]
- Formatted ... [122]
- Formatted ... [123]
- Formatted ... [124]
- Formatted ... [125]
- Formatted ... [126]
- Formatted ... [127]
- Formatted ... [128]
- Formatted ... [129]
- Formatted ... [130]
- Formatted ... [131]
- Formatted ... [132]
- Formatted ... [133]
- Formatted ... [134]
- Formatted ... [135]
- Formatted ... [136]
- Formatted ... [137]
- Formatted ... [138]
- Formatted ... [139]
- Formatted ... [140]
- Formatted ... [141]
- Formatted ... [142]
- Formatted ... [143]
- Formatted ... [144]
- Formatted ... [145]
- Formatted ... [146]
- Formatted ... [147]
- Formatted ... [148]
- Formatted ... [149]
- Formatted ... [150]
- Formatted ... [151]
- Formatted ... [152]
- Formatted ... [153]
- Formatted ... [154]
- Formatted ... [155]
- Formatted ... [156]
- Formatted ... [157]
- Formatted ... [158]
- Formatted ... [159]
- Formatted ... [160]
- Formatted ... [161]
- Formatted ... [162]
- Formatted ... [163]
- Formatted ... [164]
- Formatted ... [165]
- Formatted ... [166]
- Formatted ... [167]
- Formatted ... [168]

### 14.23 Example: Calculation of Zonal Generation Tariffs and Charges

Deleted: .....  
Deleted: 2

#### Wider

Let us consider all nodes in a generation zone, in this example

Deleted: 4  
Deleted: 4: Western Highland.¶

The table below shows a sample output of the transport model comprising the node, the Peak Security wider nodal marginal km and Year Round wider nodal marginal km (observed on non-local assets) of an injection at the node with a consequent withdrawal across distributed reference node, the generation sited at the node, scaled to ensure total national generation equals total national demand, for both Peak Security and Year Round generation backgrounds.

Deleted: at the

Deleted: ¶ Genzone ... [172]

Gen Zone	Node	Wider Nodal Marginal km (Peak Security)	Scaled Generation (Peak Security)	Wider Nodal Marginal km (Year Round)	Scaled Generation (Year Round)
4	ABNE10	5.73	0.00	459.90	0.00
4	CLAY1S	239.67	0.00	306.47	0.00
4	CLUN1S	46.41	22.90	502.16	18.76
4	COUA10	45.39	0.00	423.30	0.00
4	DYCE1Q	162.70	0.00	357.81	0.00
4	ERRO10	46.82	56.13	534.03	45.99
4	FIDD1B	91.88	0.00	220.59	0.00
4	FINL1Q	79.69	12.35	495.63	10.12
4	GRIF1S	33.31	0.00	521.16	71.40
4	KIIN10	79.69	0.00	495.63	0.00
4	LOCH10	79.69	35.18	495.63	28.82
4	MILC10	117.69	0.00	328.86	0.00
4	PERS20	266.00	0.00	384.05	0.00
4	TUMB1Q	46.82	0.00	536.27	0.00
	<b>Totals</b>		<b>126.56</b>		<b>175.09</b>

In order to calculate the generation tariff we would carry out the following steps.

- (i) calculate the generation weighted wider nodal shadow costs.

For this example zone, this would be as follows:

Deleted: 4  
Deleted: Genzone ... [173]

Gen Zone	Node	Wider Nodal Marginal km (Peak Security)	Scaled Generation (Peak Security) (MW)	Gen Weighted Wider Nodal Marginal km (Peak Security)	Wider Nodal Marginal km (Year Round)	Scaled Generation (Year Round) (MW)	Gen weighted Wider Nodal Marginal km (Year Round)
4	CLUN1S	46.41	22.90	8.39	502.16	18.76	5
4	ERRO10	46.82	56.13	20.76	534.03	45.99	14
4	FINL1Q	79.69	12.35	7.77	495.63	10.12	2
4	GRIF1S	N/A	N/A	N/A	521.16	71.40	21
4	LOCH10	79.69	35.18	22.15	495.63	28.82	8
	<b>Totals</b>		<b>126.56</b>			<b>175.09</b>	

i.e.  $79.69 \times 35.18$   
126.56

(ii) sum the generation weighted wider nodal shadow costs to give Peak Security and Year Round zonal figures.  
 For this example zone this would be:

**Peak Security:**  $(8.39 + 20.76 + 7.77 + 22.15)$  km = **59.07 km**

**Year Round:**  $(53.80 + 140.27 + 28.65 + 212.52 + 81.58)$  km = **516.82 km**

(iii) In this example we have assumed that Low Carbon and Carbon generation TEC in the zone are equal, therefore the sharing is applied at 50%.

Year Round Shared marginal km =  $50\% * 516.82\text{km} = 258.41 \text{ km}$

Year Round Not-Shared marginal km =  $(516.82 - 258.41)\text{km} = 258.41 \text{ km}$

(iv) calculate the initial Peak Security wider transport tariff, Year Round Shared wider transport tariff and Year Round Not-Shared wider transport tariff by multiplying the figures in (iii) above by the expansion constant and locational security factor (& dividing by 1000 to put into units of £/kW).

For this example zone and assuming an expansion constant of £10.07/MWkm and a locational security factor of 1.8:

a) Initial Peak Security wider tariff -

$$\frac{59.07 \text{ km} * \text{£}10.07/\text{MWkm} * 1.8}{1000} = \text{£}1.071/\text{kW}$$

b) Initial Year Round Shared wider tariff -

$$\frac{258.41 \text{ km} * \text{£}10.07/\text{MWkm} * 1.8}{1000} = \text{£}4.684/\text{kW}$$

c) Initial Year Round Not-Shared wider tariff -

$$\frac{258.41 \text{ km} * \text{£}10.07/\text{MWkm} * 1.8}{1000} = \text{£}4.684/\text{kW}$$

**Local**

(v) If we assume (for the sake of this example) that the generator connecting at CLUN1S is a thermal plant with a Peak Security flag of 1 and an Annual Load Factor (ALF) of 60%, which connects via 10km of 132kV 100MVA rated single circuit overhead line from the nearest MITS node, with no redundancy, the substation is rated at less than 1320MW, and there is no other generation or demand connecting to this circuit, then:

a) referencing the table in paragraph 14.15.106, the local substation tariff will be £0.133/kW; and

b) running the transport model with a local circuit expansion factor of 10.0 applied to the 10km of overhead line connecting CLUN1S to the nearest MITS node and the wider circuit expansion factors applied to all other circuits, gives a local nodal marginal cost of 100MWkm. This is the additional MWkm costs associated with the node's local assets. Applying the expansion constant of £10.07/MWkm and local security factor of 1.0 and dividing by 1000 gives a local circuit tariff of £1.007/kW.

**Residual**

Deleted: 4
Deleted: (366.48+ 26 (... [174])
Deleted: + 100.67
Deleted: 1127.81km (... [175])
Deleted: <sp>
Deleted: . . 1127.81k (... [176])
Formatted (... [177])
Deleted: ) = 888.21
Formatted (... [178])
Formatted (... [179])
Formatted (... [180])
Formatted (... [181])
Formatted (... [182])
Formatted (... [183])
Deleted: calculate the (... [184])
Formatted (... [185])
Formatted (... [186])
Formatted (... [187])
Formatted (... [188])
Formatted (... [189])
Formatted (... [190])
Formatted (... [191])
Formatted (... [192])
Formatted (... [193])
Formatted (... [194])
Formatted (... [195])
Formatted (... [196])
Formatted (... [197])
Formatted (... [198])
Formatted (... [199])
Formatted (... [200])
Deleted: ¶
Formatted (... [201])
Formatted (... [202])
Deleted: figure
Deleted: i
Deleted: 4
Deleted: 888.21
Formatted (... [203])
Deleted: 6.10
Deleted: .
Formatted (... [204])
Formatted (... [205])
Formatted: Bullets and Numbering (... [206])
Formatted (... [207])
Formatted (... [208])
Formatted: Bullets and Numbering (... [209])
Deleted: generation
Deleted: CEAN1Q
Deleted: 67
Deleted: CEAN1Q

(vi) We now need to calculate the residual tariff. This is calculated by taking the total revenue to be recovered from generation (calculated as c.27% of total The Company TNUoS target revenue for the year) less the revenue which would be recovered through the generation transport tariffs divided by total expected generation.

Assuming the total revenue to be recovered from TNUoS is £1067m, the total recovery from generation would be (27% x £1067m) = £288m. Assuming the total recovery from both wider generation transport tariffs (i.e. wider Peak Security tariff, wider Year Round Shared tariff and wider Year Round Not-Shared tariff) and local generation tariffs (i.e. local substation tariff and local circuit tariff) is £70m and total forecast chargeable generation capacity is 67000MW, the Generation residual tariff would be as follows:

$$\frac{£288 - £70m}{65000MW} = £3.35/kW$$

(vii) Therefore the charges for thermal plant with a TEC of 100MW and an ALF of 60% connecting at CLUN1S is:

- = Wider Peak Security Tariff \* PS Flag \* TEC
- = Wider Year Round Shared Tariff \* ALF \* TEC
- = Wider Year Round Not-Shared Tariff \* TEC
- = Local substation Tariff \* TEC
- = Local circuit Tariff \* TEC
- = Residual Tariff \* TEC

For this example, the above charges are –

- = 1.071 \* 1 \* 100,000
- = 4.684 \* 0.6 \* 100,000
- = 4.684 \* 100,000
- = 0.133 \* 100,000
- = 1.007 \* 100,000
- = 3.35 \* 100,000

(effectively, £13.055/kW \* 100,000kW = £1,305,500)

(viii) Alternatively, if we assume that the generator connecting at CLUN1S is an intermittent wind generation plant (instead of a thermal plant) with a TEC of 100MW, PS Flag of 0 and an ALF of 30%, then the charges payable will be –

- = 1.071 \* 0 \* 100,000
- = 4.684 \* 0.3 \* 100,000
- = 4.684 \* 100,000
- = 0.133 \* 100,000
- = 1.007 \* 100,000
- = 3.35 \* 100,000

(effectively, £10.579/kW \* 100,000kW = £1,057,900)

**Formatted:** Indent: Left: 0 cm

**Formatted:** Bullets and Numbering

**Formatted:** Centered

**Deleted:** to get to

**Deleted:** final tariff

**Deleted:** generator

**Deleted:** a particular node, we simply sum the generation residual tariff calculated in (vi), the wider zonal transport tariff calculated in (iv), the local substation tariff calculated in (v(a)) , and the local circuit tariff calculated in (v(b)). In

**Formatted:** Font: 11 pt, Highlight

**Formatted:** Highlight

**Formatted:** Highlight

**Formatted:** Font: 11 pt, Highlight

**Deleted:** :¶

**Deleted:** ¶  
For CEAN1Q : . £16.10/kW + £3.35/kW + £

**Deleted:** 135/kW + £

**Formatted:** Font: 11 pt, Highlight

**Formatted:** Font: 11 pt, Font color: Auto, English (U.K.), Do not check spelling or grammar, Highlight

**Formatted:** Font: 11 pt, Highlight

**Formatted:** Highlight

**Formatted:** Highlight

**Formatted:** Font: 11 pt, Highlight

**Formatted:** Left, Indent: Left: 0.25 cm

**Formatted:** Font: 11 pt, English (U.K.)

**Deleted:** /kW = £20.592 /kW

**Formatted:** English (U.K.)

**Deleted:** ¶  
To summarise, in order to calculate the generation tariffs, we evaluate a generation weighted zonal marginal km cost, modify by a re-referencing quantity to ensure that our revenue recovery split between generation and demand is correct, multiply by the security factor, then we add a constant (termed the residual cost) to give the overall tariff. ¶

-----Page Break-----  
¶

## 14.24 Example: Calculation of Zonal Demand Tariff

Deleted: 3

Let us consider all nodes in a demand zone [in this example](#).

Deleted: 14: South Western

The table below shows a sample output of the transport model comprising the node, the [Peak Security and Year Round](#) marginal km of an injection at the node with a consequent withdrawal at the [distributed](#) reference node, the generation sited at the node, scaled to ensure total national generation = total national demand and the demand sited at the node.

Deleted: ¶  
Demand Zone

... [210]

<u>Demand Zone</u>	<u>Node</u>	<u>Peak Security Nodal Marginal</u> km	<u>Year Round Nodal Marginal</u> km	<u>Demand (MW)</u>
14	ABHA4A	-77.25	-230.25	127
14	ABHA4B	-77.27	-230.12	127
14	ALVE4A	-82.28	-197.18	100
14	ALVE4B	-82.28	-197.15	100
14	AXMI40 SWEB	-125.58	-176.19	97
14	BRWA2A	-46.55	-182.68	96
14	BRWA2B	-46.55	-181.12	96
14	EXET40	-87.69	-164.42	340
14	HINP20	-46.55	-147.14	0
14	HINP40	-46.55	-147.14	0
14	INDQ40	-102.02	-262.50	444
14	IROA20 SWEB	-109.05	-141.92	462
14	LAND40	-62.54	-246.16	262
14	MELK40 SWEB	18.67	-140.75	83
14	SEAB40	65.33	-140.97	304
14	TAUN4A	-66.65	-149.11	55
14	TAUN4B	-66.66	-149.11	55
	<b>Totals</b>			<b>2748</b>

In order to calculate the demand tariff we would carry out the following steps:

- (i) calculate the demand weighted nodal shadow costs

For this example zone this would be as follows:

<u>Demand zone</u>	<u>Node</u>	<u>Peak Security Nodal Marginal km</u>	<u>Year Round Nodal Marginal km</u>	<u>Demand (MW)</u>	<u>Peak Security Demand Weighted Nodal Marginal km</u>	<u>Year Round Demand Weighted Nodal Marginal km</u>
14	ABHA4A	-77.25	-230.25	127	-3.57	-10.64
14	ABHA4B	-77.27	-230.12	127	-3.57	-10.64
14	ALVE4A	-82.28	-197.18	100	-2.99	-7.17
14	ALVE4B	-82.28	-197.15	100	-2.99	-7.17
14	AXMI40 SWEB	-125.58	-176.19	97	-4.43	-6.22
14	BRWA2A	-46.55	-182.68	96	-1.63	-6.38
14	BRWA2B	-46.55	-181.12	96	-1.63	-6.33
14	EXET40	-87.69	-164.42	340	-10.85	-20.34
14	INDQ40	-102.02	-262.50	444	-16.48	-42.41
14	IROA20 SWEB	-109.05	-141.92	462	-18.33	-23.86
14	LAND40	-62.54	-246.16	262	-5.96	-23.47
14	MELK40 SWEB	18.67	-140.75	83	0.56	-4.25
14	SEAB40	65.33	-140.97	304	7.23	-15.59
14	TAUN4A	-66.65	-149.11	55	-1.33	-2.98
14	TAUN4B	-66.66	-149.11	55	-1.33	-2.98
	<b>Totals</b>			<b>2748</b>	<b>-49.19</b>	<b>-190.43</b>

Deleted: 14  
 Deleted: Demand zor (... [211])  
 Deleted: <sp>  
 Deleted: 287.99km - (-239.60km) = **527.59 km**  
 calculate the transport tariff by multiplying the figure in (iii) above by the expansion constant (& dividing by 1000 to put into units of £/kW):

- (ii) sum the Peak Security and Year Round demand weighted nodal shadow costs to give zonal figures. For this example zone this is shown in the above table and is 49.19km for Peak Security background and 190.43km for Year Round background.

Deleted: 14

- (iii) calculate the transport tariffs by multiplying the figures in (ii) above by the expansion constant (& dividing by 1000 to put into units of £/kW):

For this example zone, assuming an expansion constant of £10.07/MWkm and a locational security factor of 1.80:

Deleted: 14

a) Peak Security tariff -  

$$\frac{49.19\text{km} * \text{£}10.07/\text{MWkm} * 1.8}{1000} = \text{£}0.89/\text{kW}$$

Deleted: .527.59km

Deleted: 9.56

Deleted: .

b) Year Round tariff -  

$$\frac{190.43\text{km} * \text{£}10.07/\text{MWkm} * 1.8}{1000} = \text{£}3.45/\text{kW}$$

- (iv) We now need to calculate the residual tariff. This is calculated by taking the total revenue to be recovered from demand (calculated as c.73% of total The Company TNUoS target revenue for the year) less the revenue which would be recovered through the demand transport tariffs divided by total expected demand.

Assuming the total revenue to be recovered from TNUoS is £1067m, the total recovery from demand would be (73% x £1067m) = £779m. Assuming the total recovery from



demand transport tariffs is £130m and total forecast chargeable demand capacity is 50000MW, the demand residual tariff would be as follows:

$$\frac{£779m - £130m}{50000MW} = \underline{£12.98/kW}$$

(v) to get to the final tariff, we simply add on the demand residual tariff calculated in (iv) to the zonal transport tariffs calculated in (iii(a)) and (iii(b))

For zone 14:

$$\underline{£0.89/kW} + \underline{£3.45/kW} + \underline{£12.98/kW} = \underline{£17.32/kW}$$

To summarise, in order to calculate the demand tariffs, we evaluate a demand weighted zonal marginal km costs, multiply by the expansion constant and locational security factor, then we add a constant (termed the residual cost) to give the overall tariff.

(vi) The final demand tariff is subject to further adjustment to allow for the minimum £0/kW demand charge. The application of a discount for small generators pursuant to Licence Condition C13 will also affect the final demand tariff.

- Deleted:** tariff
- Deleted:** iv)
- Formatted:** Font: 11 pt, Dutch (Belgium)
- Formatted:** Font: 11 pt, Dutch (Belgium)
- Formatted:** Dutch (Belgium)
- Deleted:** £9.56
- Formatted:** Font: 11 pt, Dutch (Belgium)
- Formatted:** Font: 11 pt, Dutch (Belgium)
- Formatted:** Font: 11 pt, Dutch (Belgium)
- Deleted:** 22.54
- Formatted:** Dutch (Belgium)
- Formatted:** Dutch (Belgium)
- Formatted:** Font: 11 pt, Dutch (Belgium)
- Formatted:** Dutch (Belgium)
- Deleted:** , modify
- Deleted:** a re-referencing quantity to ensure that our revenue recovery split between generation and demand is correct
- Deleted:** ¶
- Formatted:** Normal, Justified, Indent: Left: 0 cm
- Deleted:** i
- Deleted:** ¶
- Formatted:** Check spelling and grammar
- Deleted:** ~~~~~
- Formatted:** Left, Indent: Left: 0 cm

## 14.25 Reconciliation of Demand Related Transmission Network Use of System Charges

This appendix illustrates the methodology used by The Company in the reconciliation of Transmission Network Use of System charges for demand. The example highlights the different stages of the calculations from the monthly invoiced amounts, right through to Final Reconciliation.

### Monthly Charges

Suppliers provide half-hourly (HH) and non-half-hourly (NHH) demand forecasts by BM Unit every quarter. An example of such forecasts and the corresponding monthly invoiced amounts, based on tariffs of £10.00/kW and 1.20p/kWh, is as follows:

	Forecast HH Triad Demand $HHD_F(kW)$	HH Monthly Invoiced Amount (£)	Forecast NHH Energy Consumption $NHHC_F(kWh)$	NHH Monthly Invoiced Amount (£)	Net Monthly Invoiced Amount (£)
Apr	12,000	10,000	15,000,000	15,000	25,000
May	12,000	10,000	15,000,000	15,000	25,000
Jun	12,000	10,000	15,000,000	15,000	25,000
Jul	12,000	10,000	18,000,000	19,000	29,000
Aug	12,000	10,000	18,000,000	19,000	29,000
Sep	12,000	10,000	18,000,000	19,000	29,000
Oct	12,000	10,000	18,000,000	19,000	29,000
Nov	12,000	10,000	18,000,000	19,000	29,000
Dec	12,000	10,000	18,000,000	19,000	29,000
Jan	7,200	(6,000)	18,000,000	19,000	13,000
Feb	7,200	(6,000)	18,000,000	19,000	13,000
Mar	7,200	(6,000)	18,000,000	19,000	13,000
Total		72,000		216,000	288,000

As shown, for the first nine months the Supplier provided a 12,000kW HH triad demand forecast, and hence paid HH monthly charges of £10,000  $((12,000kW \times £10.00/kW)/12)$  for that BM Unit. In January the Supplier provided a revised forecast of 7,200kW, implying a forecast annual charge reduced to £72,000  $(7,200kW \times £10.00/kW)$ . The Supplier had already paid £90,000, so the excess of £18,000 was credited back to the supplier in three £6,000 instalments over the last three months of the year.

The Supplier also initially provided a 15,000,000kWh NHH energy consumption forecast, and hence paid NHH monthly charges of £15,000  $((15,000,000kWh \times 1.2p/kWh)/12)$  for that BM Unit. In July the Supplier provided a revised forecast of 18,000,000kWh, implying a forecast annual charge increased to £216,000  $(18,000,000kWh \times 1.2p/kWh)$ . The Supplier had already paid £45,000, so the remaining £171,000 was split into payments of £19,000 for the last nine months of the year.

The right hand column shows the net monthly charges for the BM Unit.

Deleted: 1

Deleted: 14.24

Deleted: 4

Formatted: Font: Arial, Font color: Dark Blue

### Initial Reconciliation (Part 1)

The Supplier's outturn HH triad demand, based on initial settlement data (and therefore subject to change in subsequent settlement runs), was 9,000kW. The HH triad demand reconciliation charge is therefore calculated as follows:

$$\text{HHD Reconciliation Charge} = (\text{HHD}_A - \text{HHD}_F) \times \text{£/kW Tariff}$$

$$= (9,000\text{kW} - 7,200\text{kW}) \times \text{£}10.00/\text{kW}$$

$$= 1,800\text{kW} \times \text{£}10.00/\text{kW}$$

$$= \text{£}18,000$$

**Formatted:** Font: Not Bold, Font color: Auto

**Formatted:** English (U.K.)

**Formatted:** Font: Not Bold, Font color: Auto, English (U.K.)

**Formatted:** Font: Not Bold, Font color: Auto

**Formatted:** English (U.K.)

To calculate monthly interest charges, the outturn HHD charge is split equally over the 12-month period. The monthly reconciliation amount is the monthly outturn HHD charge less the HH monthly invoiced amount. Interest payments are calculated based on these monthly reconciliation amounts using Barclays Base Rate.

Please note that payments made to BM Units with a net export over the Triad, based on initial settlement data, will also be reconciled at this stage.

As monthly payments will not be made on the basis of a negative forecast, the HHD Reconciliation Charge for an exporting BM Unit will represent the full actual payment owed to that BM Unit (subject to adjustment by subsequent settlement runs). Interest will be calculated as described above.

### Initial Reconciliation (Part 2)

The Supplier's outturn NHH energy consumption, based on initial settlement data, was 17,000,000kWh. The NHH energy consumption reconciliation charge is therefore calculated as follows:

$$\text{NHH Reconciliation Charge} = \frac{(\text{NHH}_A - \text{NHH}_F)}{100} \times \text{p/kWh Tariff}$$

$$= \frac{(17,000,000\text{kWh} - 18,000,000\text{kWh})}{100} \times 1.20\text{p/kWh}$$

$$= \frac{-1,000,000\text{kWh}}{100} \times 1.20\text{p/kWh}$$

$$= \text{-£}12,000$$

**Formatted:** Font: Not Bold, Font color: Auto

**Formatted:** Font: Not Bold, Font color: Auto

**Formatted:** Font: Not Bold, Font color: Auto

[worked example 4.xls - Initial!J104](#)

The monthly reconciliation amount is equal to the outturn energy consumption charge for that month less the NHH monthly invoiced amount. Interest payments are calculated based on the monthly reconciliation amounts using Barclays Base Rate.

The net initial TNUoS demand reconciliation charge is therefore £6,000 (£18,000 - £12,000).

### Final Reconciliation

Finally, let us now suppose that after all final Settlement data has been received (up to 14 months after the relevant dates), the outturn HH triad demand and NHH energy consumption values were 9,500kW and 16,500,000kWh, respectively.

$$\begin{aligned} \text{Final HH Reconciliation Charge} &= (9,500\text{kW} - 9,000\text{kW}) \times \text{£}10.00/\text{kW} \\ &= \text{£}5,000 \end{aligned}$$

$$\begin{aligned} \text{Final NHH Reconciliation Charge} &= \frac{(16,700,000\text{kWh} - 17,000,000\text{kWh}) \times 1.20\text{p}/\text{kWh}}{100} \\ &= -\text{£}3,600 \end{aligned}$$

Consequently, the net final TNUoS demand reconciliation charge will be £1,400.

Interest payments are calculated based on the monthly reconciliation amounts using Barclays Base Rate.

Outturn data for BM Units with a net export over the Triad will be received at this stage and final reconciliation will be carried out, as required. Interest will be calculated as described above.

### Terminology:

**HHD<sub>A</sub>** = The Supplier's outturn half-hourly metered Triad Demand (kW) for the demand zone concerned.

**HHD<sub>F</sub>** = The Supplier's forecast half-hourly metered Triad Demand (kW) for the demand zone concerned.

**NHHC<sub>A</sub>** = The Supplier's outturn non-half-hourly metered daily Energy Consumption (kWh) for the period 16:00 hrs to 19:00 hrs inclusive (i.e. settlement periods 33 to 38) from April 1<sup>st</sup> to March 31<sup>st</sup>, for the demand zone concerned.

**NHHC<sub>F</sub>** = The Supplier's forecast non-half-hourly metered daily Energy Consumption (kWh) for the period 16:00 hrs to 19:00 hrs inclusive (i.e. settlement periods 33 to 38) from April 1<sup>st</sup> to March 31<sup>st</sup>, for the demand zone concerned.

**£/kW Tariff** = The £/kW Demand Tariff as shown in Schedule 1 of **The Statement of Use of System Charges** for the demand zone concerned.

**p/kWh Tariff** = The Energy Consumption Tariff shown in Schedule 1 of **The Statement of Use of System Charges** for the demand zone concerned.

## 14.26 Classification of parties for charging purposes

Deleted: 25

In the event of any conflict between this Appendix and the main text within this Statement, the main text within the Statement shall take precedence.

In the following diagrams, the parties liable for Transmission Network Use of System charges are outlined in red.

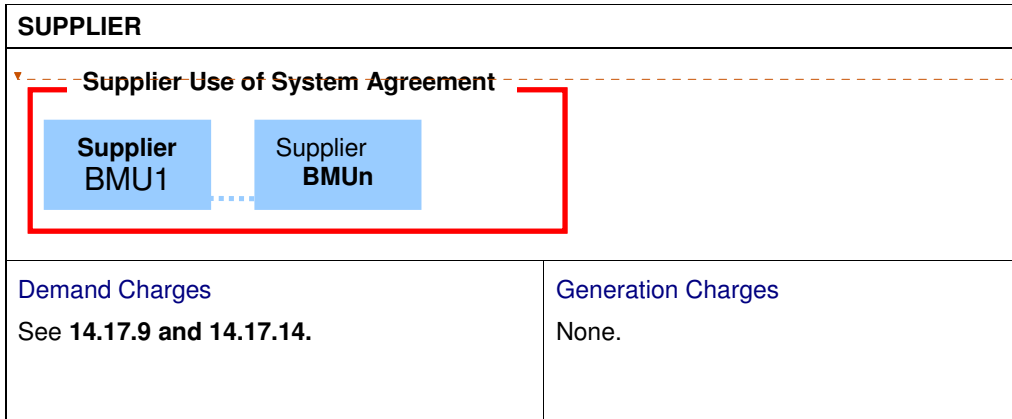

Deleted: ¶

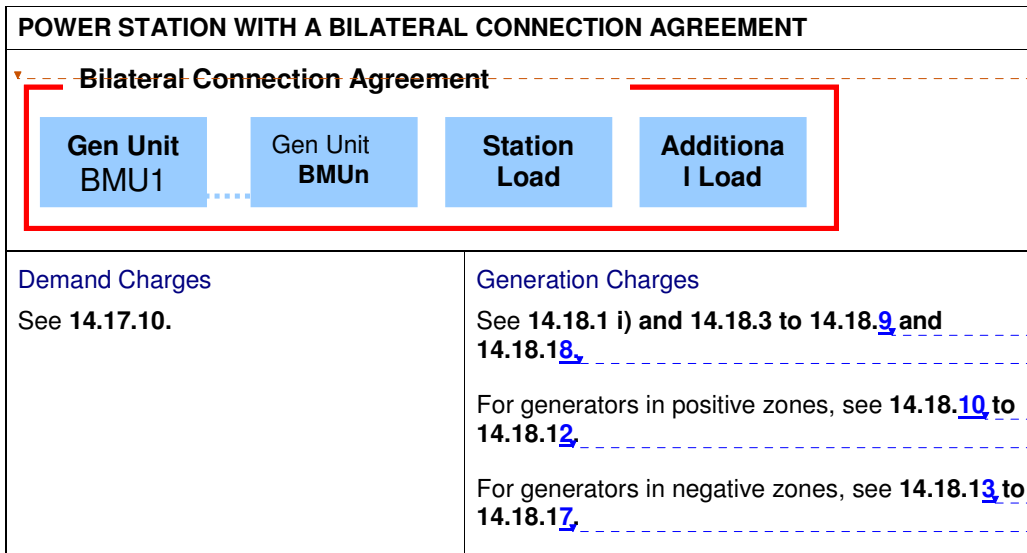

Deleted: ¶

¶  
¶  
¶  
¶

Deleted: 8

Deleted: 7.

Deleted: 9

Deleted: 1

Deleted: 2

Deleted: 6

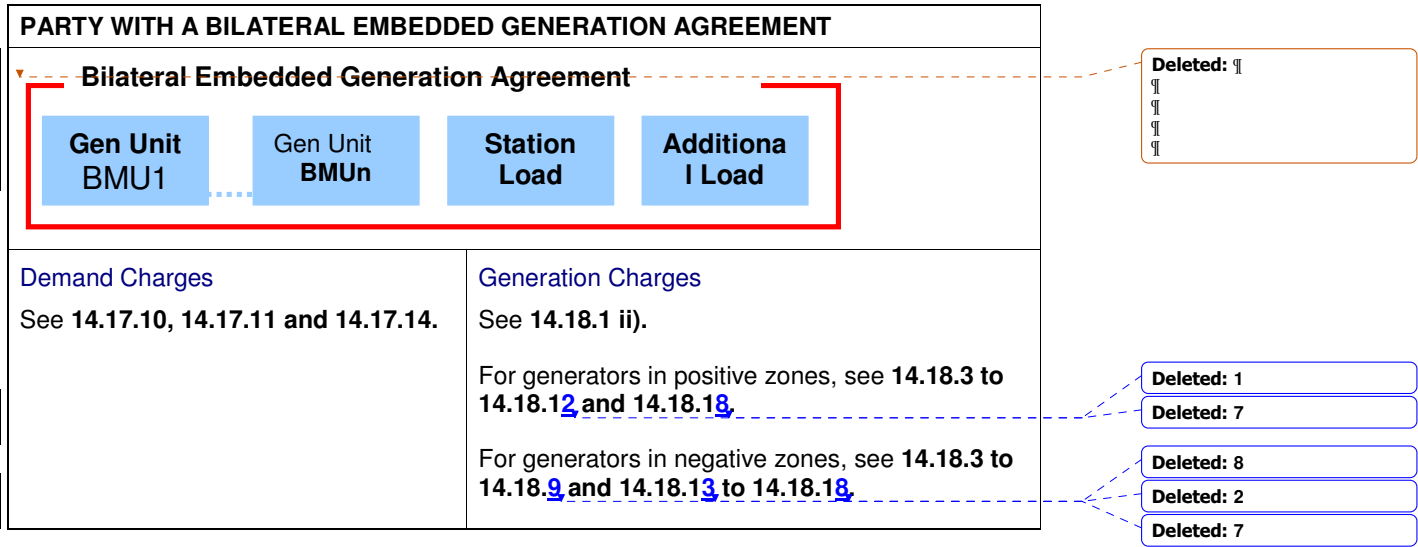

## 14.27 Transmission Network Use of System Charging Flowcharts

Deleted: 6

The following flowcharts illustrate the parties liable for Demand and Generation TNUoS charges and the calculation of those charges.

In the event of any conflict between this Appendix and the main text within this Statement, the main text within the Statement shall take precedence.

### Demand Charges

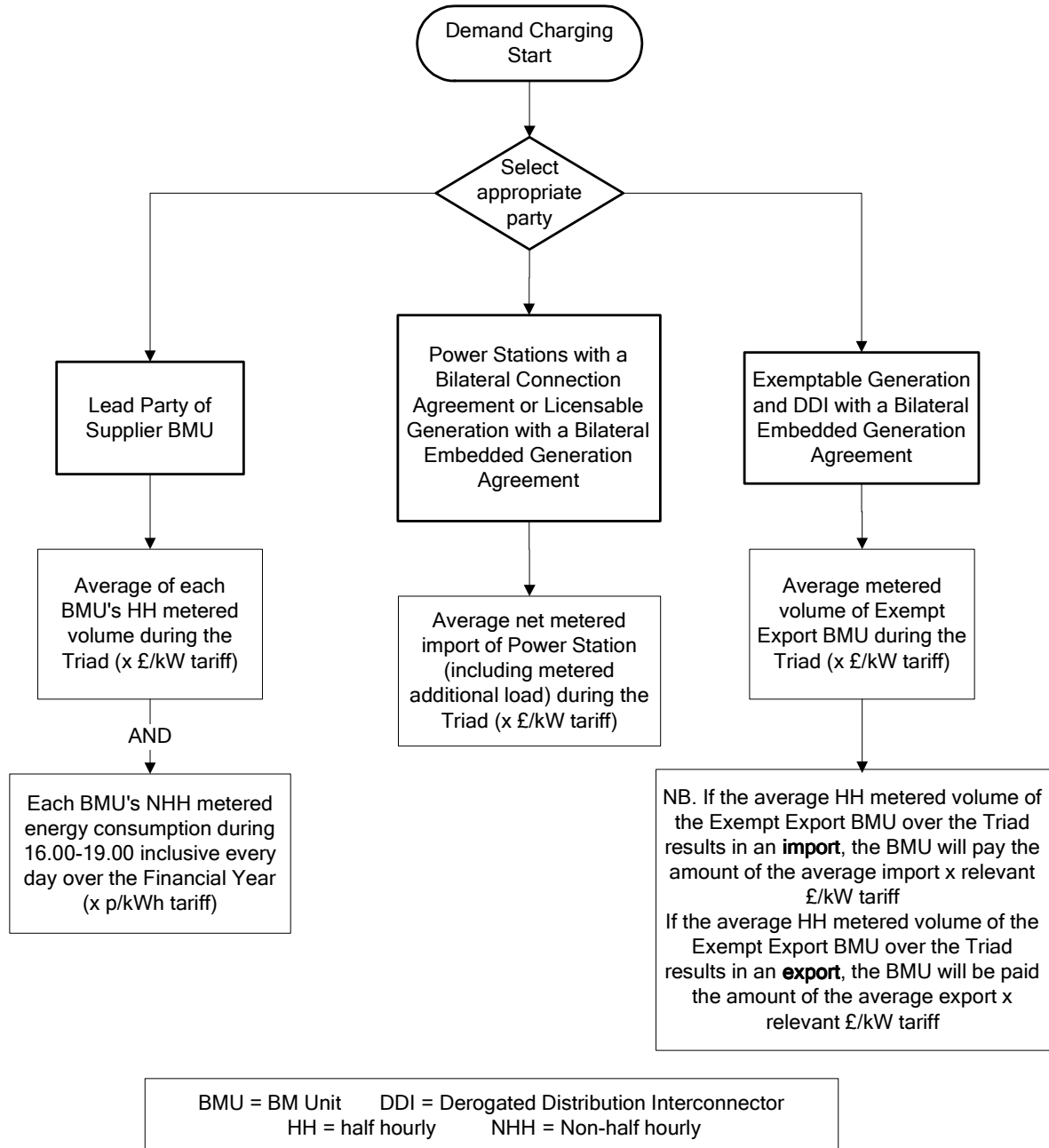

Generation Charges

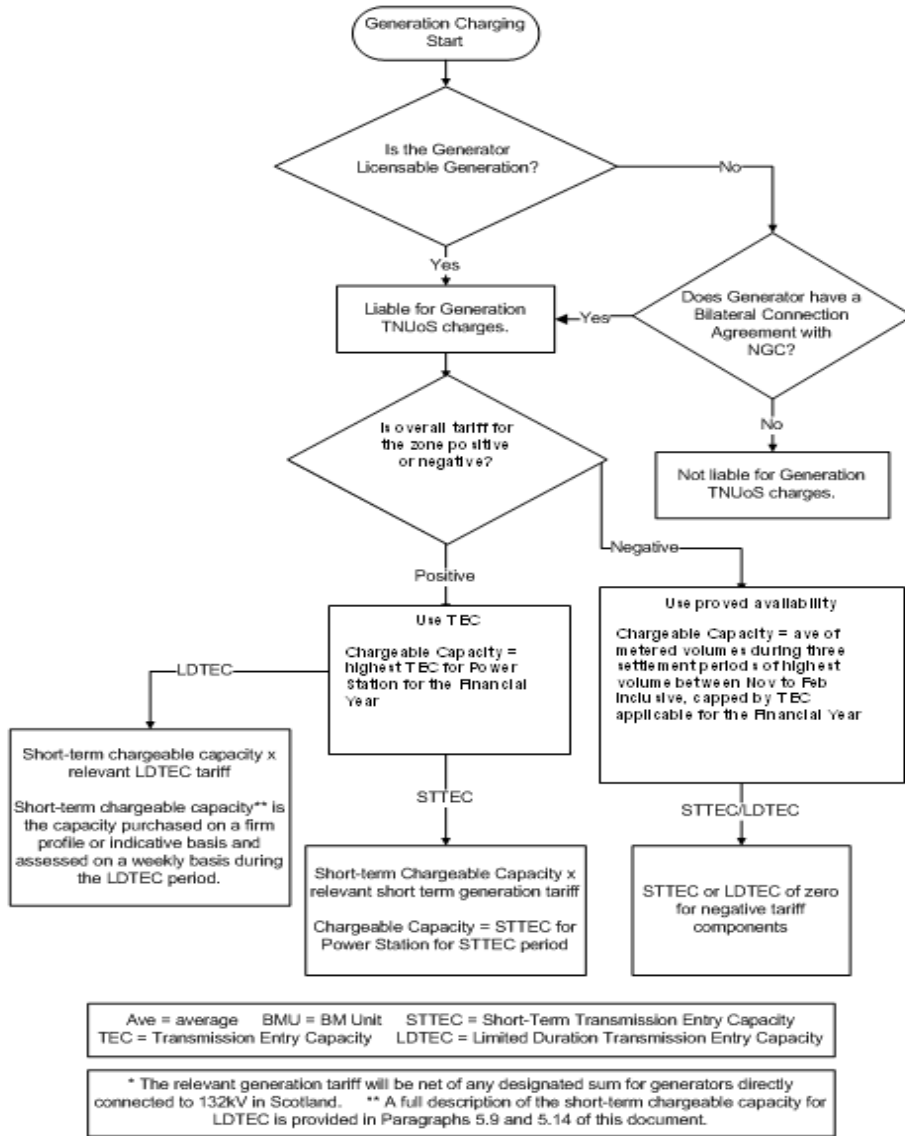

Short-term chargeable capacity x relevant LDTEC tariff

Short-term chargeable capacity\*\* is the capacity purchased on a firm profile or indicative basis and assessed on a weekly basis during the LDTEC period.

Ave  
TEC = T

\* Th  
connecte

Deleted:



## 14.28 Example: Determination of The Company's Forecast for Demand Charge Purposes

Deleted: 7

The Company will use the latest available settlement data for calculation of HH demand and NHH energy consumption forecasts for the Financial Year.

The Financial Year runs from 1<sup>st</sup> April to 31<sup>st</sup> March inclusive and for the purpose of these examples the year April 2005 to March 2006 is used.

Where the preceding year's settlement data is not available at the time that The Company needs to calculate its forecast, The Company will use settlement data from the corresponding period in Financial Year minus two unless indicated otherwise.

All values used with the examples are purely for illustrative purposes only.

### i) Half-Hourly (HH) Metered Demand Forecast – Existing User

At the time of calculation of a HH demand forecast before the relevant Financial Year (approximately 10<sup>th</sup> March), The Company will be aware at a system level which dates will be used for the determination of Triad. However, The Company may not have settlement data at a User level if the Triad dates were to span a period that includes the latter half of February.

When undertaking forecasting before the relevant Financial Year, The Company will use the User's Triad demand for the previous year for its forecast providing it holds User settlement data for this period, thus:

$$F = T$$

where:

F = Forecast of User's HH demand at Triad for the Financial Year

T = User's HH demand at Triad in Financial Year minus one

Where The Company determines its forecast within a Financial Year:

$$F = T * D/P$$

where:

F = Forecast of User's HH demand at Triad for the Financial Year

T = User's HH demand at Triad in the preceding Financial Year

D = User's average half hourly metered demand in settlement period 35 in the Financial Year to date

P = User's average half hourly metered demand in settlement period 35 for the period corresponding to D in the preceding Financial Year

Where The Company determines its forecast before the relevant Financial Year and User settlement data for the Triad period is not available, The Company shall apply the formula immediately above (within year forecast) but substitute the following definitions for the values T, D, and P:

T = User's HH demand at Triad in the Financial Year minus two

D = User's average half hourly metered demand in settlement period 35 in the Financial Year minus one, to date

P = User's average half hourly metered demand in settlement period 35 for the period corresponding to D in the Financial Year minus two

**Example** (where User settlement data is not yet available for the Triad period):

The Company calculates a HH demand forecast on the above methodology at 10<sup>th</sup> March 2005 for the period 1<sup>st</sup> April 2005 to 31<sup>st</sup> March 2006.

$$F = 10,000 * 13,200 / 12,000$$

$$F = 11,000 \text{ kWh}$$

where:

T = 10,000 kWh (period November 2003 to February 2004)

D = 13,200 kWh (period 1<sup>st</sup> April 2004 to 15<sup>th</sup> February 2005#)

P = 12,000 kWh (period 1<sup>st</sup> April 2003 to 15<sup>th</sup> February 2004)

# Latest date for which settlement data is available.

**ii) Non Half-Hourly (NHH) Metered Energy Consumption Forecast – Existing User**

$$F = E * D/P$$

where:

F = Forecast of User's NHH metered energy consumption for the Financial Year

E = User's summed NHH energy consumption over the hours 16:00 to 19:00 for each day in the preceding Financial Year

D = User's summed NHH energy consumption for the hours 16:00 to 19:00 for each day for the Financial Year to date

P = User's summed NHH energy consumption for the hours 16:00 to 19:00 for each day for the period corresponding to D in the preceding Financial Year

**Example:**

The Company calculates a NHH energy consumption forecast on the above methodology at 10<sup>th</sup> June 2005 for the period 1<sup>st</sup> April 2005 to 31<sup>st</sup> March 2006.

$$F = 50,000,000 * 4,400,000 / 4,000,000$$

$$F = 55,000,000 \text{ kWh}$$

where:

E = 50,000,000 kWh (period 1<sup>st</sup> April 2004 to 31<sup>st</sup> March 2005)

D = 4,400,000 kWh (period 1<sup>st</sup> April 2005 to 15<sup>th</sup> May 2005#)

P = 4,000,000 kWh (period 1<sup>st</sup> April 2004 to 15<sup>th</sup> May 2004)

# Latest date for which settlement data is available

Where forecasting before the relevant Financial Year concerned, The Company would in the above example use values for E and P from Financial Year 2003/04 and D from Financial Year 2004/05.

**iii) Half-Hourly (HH) Metered Demand Forecast – New User**

F = M \* T/W

where:

F = Forecast of User's HH metered demand at Triad for the Financial Year

M = User's HH average weekday period 35 demand for the last complete month for which settlement data is available

T = Total system HH demand at Triad in the preceding Financial Year

W = Total system HH average weekday settlement period 35 metered demand for the corresponding period to M for the preceding year

**Example:**

The Company calculates a HH demand forecast on the above methodology at 10<sup>th</sup> September 2005 for a new User registered from 10<sup>th</sup> June 2005 for the period 10<sup>th</sup> June 2004 to 31<sup>st</sup> March 2006.

F = 1,000 \* 17,000,000 / 18,888,888

F = 900 kWh

where:

M = 1,000 kWh (period 1<sup>st</sup> July 2005 to 31<sup>st</sup> July 2005)

T = 17,000,000 kWh (period November 2004 to February 2005)

W = 18,888,888 kWh (period 1<sup>st</sup> July 2004 to 31<sup>st</sup> July 2004)

**iv) Non Half Hourly (NHH) Metered Energy Consumption Forecast – New User**

F = J + (M \* R/W)

where:

- F = Forecast of User's NHH metered energy consumption for the Financial Year
- J = Residual part month summed NHH metered energy consumption for the hours 16:00 to 19:00 for each day where new User registration takes place other than on the first of a month
- M = User's summed NHH metered energy consumption for the hours 16:00 to 19:00 for each day for the last complete month for which settlement data is available
- R = Total system summed NHH metered energy consumption for the hours 16:00 to 19:00 for each day for the period from the start of that defined under M but for the preceding year and until the end of that preceding Financial Year
- W = Total system summed NHH metered energy consumption for the hours 16:00 to 19:00 for each day for the period identified in M but for the preceding Financial Year

**Example:**

The Company calculates a NHH energy consumption forecast on the above methodology at 10<sup>th</sup> September 2005 for a new User registered from 10<sup>th</sup> June 2005 for the period 10<sup>th</sup> June 2005 to 31<sup>st</sup> March 2006.

$$F = 500 + (1,000 * 20,000,000,000 / 2,000,000,000)$$

$$F = 10,500 \text{ kWh}$$

where:

$$J = 500 \text{ kWh (period 10}^{\text{th}} \text{ June 2005 to 30}^{\text{th}} \text{ June 2005)}$$

$$M = 1,000 \text{ kWh (period 1}^{\text{st}} \text{ July 2005 to 31}^{\text{st}} \text{ July 2005)}$$

$$R = 20,000,000,000 \text{ kWh (period 1}^{\text{st}} \text{ July 2004 to 31}^{\text{st}} \text{ March 2005)}$$

$$W = 2,000,000,000 \text{ kWh (period 1}^{\text{st}} \text{ July 2004 to 31}^{\text{st}} \text{ July 2004)}$$

## 14.29 Stability & Predictability of TNUoS tariffs

Deleted: 8

### Stability of tariffs

The Transmission Network Use of System Charging Methodology has a number of elements to enhance the stability of the tariffs, which is an important aspect of facilitating competition in the generation and supply of electricity. This appendix seeks to highlight those elements.

Each node of the transmission network is assigned to a zone. The result of this is to dampen fluctuations that would otherwise be observed at a given node caused by changes in generation, demand, and network parameters. The criteria used to establish generation zones are part of the methodology and are described in Paragraph 14.15.33.

Deleted: 26

These zones are themselves fixed for the duration of the price control period. The methodology does, however, allow these to be revisited in exceptional circumstances to ensure that the charges remain reasonably cost reflective or to accommodate changes to the network. In rare circumstances where such a re-zoning exercise is required, this will be undertaken in such a way that minimises the adverse impact on Users. This is described in Paragraph 14.15.36.

Deleted: 29

In addition to fixing zones, other key parameters within the methodology are also fixed for the duration of the price control period or annual changes restricted in some way. Specifically:

- the expansion constant, which reflects the annuitised value of capital investment required to transport 1MW over 1km by a 400kV over-head line, changes annually according to RPI. The other elements used to derive the expansion constant are only reviewed at the beginning of a price control period to ensure that it remains cost-reflective. This review will consider those components outlined in Paragraph 14.15.50 to Paragraph 14.15.60.
- the expansion factors, which are set on the same basis of the expansion constant and used to reflect the relative investment costs in each TO region of circuits at different transmission voltages and types, are fixed for the duration price control. These factors are reviewed at the beginning of a price control period and will take account of the same factors considered in the review of the expansion constant.
- the locational security factor, which reflects the transmission security provided under the NETS Security and Quality of Supply Standard, is fixed for the duration of the price control period and reviewed at the beginning of a price control period.

Deleted: 31

Deleted: 41

### Predictability of tariffs

The Company revises TNUoS tariffs each year to ensure that these remain cost-reflective and take into account changes to allowable income under the price control and RPI. There are a number of provisions within The Company's Transmission Licence and the CUSC designed to promote the predictability of annually varying charges. Specifically, The Company is required to give the Authority 150 days notice of its intention to change use of system charges together with a reasonable assessment of the proposals on those charges; and to give Users 2 months written notice of any revised charges. The Company typically provides an additional months notice of revised charges through the publication of "indicative" tariffs. Shorter notice periods are permitted by the framework but only following consent from the Authority.

These features require formal proposals to change the Transmission Use of System Charging Methodology to be initiated in October to provide sufficient time for a formal consultation and the Authority's veto period before charges are indicated to Users.

More fundamentally, The Company also provides Users with the tool used by The Company to calculate tariffs. This allows Users to make their own predictions on how future changes in the generation and supply sectors will influence tariffs. Along with the price control information, the data from the Seven Year Statement, and Users own prediction of market activity, Users are able to make a reasonable estimate of future tariffs and perform sensitivity analysis.

To supplement this, The Company also prepares an annual information paper that provides an indication of the future path of the locational element of tariffs over the next five years.<sup>4</sup> This analysis is based on data included within the Seven Year Statement. This report typically includes:

- an explanation of the events that have caused tariffs to change;
- sensitivity analysis to indicate how generation and demand tariffs would change as a result of changes in generation and demand at certain points on the network that are not included within the SYS;
- an assessment of the compliance with the zoning criteria throughout the five year period to indicate how generation zones might need to change in the future, with a view to minimising such changes and giving as much notice of the need, or potential need, to change generation zones; and
- a complete dataset for the DCLF Transport Model developed for each future year, to allow Users to undertake their own sensitivity analysis for specific scenarios that they may wish to model.

The first year of tariffs forecasted in the annual information paper are updated twice throughout the proceeding financial year as the various Transport and Tariff model inputs are received or amended. These updates are in addition to the Authority 150 days notice and publication of “indicative” tariffs.

| In addition, The Company will, when revising generation charging zones prior to a new price control period, undertake a zoning consultation that uses data from the latest information paper. The purpose of this consultation will be to ensure tariff zones are robust to contracted changes in generation and supply, which could be expected to reduce the need for re-zoning exercises within a price control period.

**Formatted:** Justified

**Deleted:** ¶  
¶  
¶  
-----Page Break-----  
¶

<sup>4</sup> <http://www.nationalgrid.com/uk/Electricity/Charges/gbchargingapprovalconditions/5/>



## CUSC - SECTION 14

### CHARGING METHODOLOGIES

#### CONTENTS

Part 2 -The Statement of the Use of System Charging Methodology

Formatted: Font: Bold

Formatted: Centered

Deleted: ¶

Section 1 – The Statement of the Transmission Use of System Charging Methodology;

14.14 Principles

14.15 Derivation of Transmission Network Use of System Tariff

14.16 Derivation of the Transmission Network Use of System Energy Consumption Tariff and Short Term Capacity Tariffs

14.17 Demand Charges

14.18 Generation Charges

14.19 Data Requirements

14.20 Applications

14.21 Transport Model Example

14.22 Illustrative Calculation of Boundary Sharing Factors (BSFs) and Not-Shared incremental km

Formatted: Font: Arial, 12 pt, Not Highlight

Deleted: 2

14.23 Example: Calculation of Zonal Generation Tariff

Deleted: 3

14.24 Example: Calculation of Zonal Demand Tariff

14.25 Reconciliation of Demand Related Transmission Network Use of System Charges

Deleted: 4

14.26 Classification of parties for charging purposes

Deleted: 5

14.27 Transmission Network Use of System Charging Flowcharts

Deleted: 6

14.28 Example: Determination of The Company's Forecast for Demand Charge Purposes

Deleted: 7

14.29 Stability & Predictability of TNUoS tariffs

Deleted: 8

Section 2 – The Statement of the Balancing Services Use of System Charging Methodology



14.30 Principles

Deleted: 29

14.31 Calculation of the Daily Balancing Services Use of System charge

Deleted: 0

14.32 Settlement of BSUoS

Deleted: 1

14.33 Examples of Balancing Services Use of System (BSUoS) Daily Charge Calculations

Deleted: 2

## CUSC - SECTION 14

### CHARGING METHODOLOGIES

14.1 Introduction

14.1.1 This section of the CUSC sets out the statement of the Connection Charging Methodology and the Statement of the Use of System Methodology

Formatted: Tabs: 2.77 cm,  
List tab + Not at 1.5 cm

Formatted: Tabs: 3.63 cm,  
List tab + Not at 3 cm

Formatted: 1,2,3, Justified,  
Indent: Left: 0 cm

## Part 2 - The Statement of the Use of System Charging Methodology

Deleted:  
Formatted: Font: Arial (W1)  
Deleted: ¶

### Section 1 – The Statement of the Transmission Use of System Charging Methodology

#### 14.14 Principles

**14.14.1** Transmission Network Use of System charges reflect the cost of installing, operating and maintaining the transmission system for the Transmission Owner (TO) Activity function of the Transmission Businesses of each Transmission Licensee. These activities are undertaken to the standards prescribed by the Transmission Licences, to provide the capability to allow the flow of bulk transfers of power between connection sites and to provide transmission system security.

Formatted: Font: 11 pt  
Formatted: Font: Arial  
Formatted: Indent: Left: 1.27 cm, Numbered + Level: 1 + Numbering Style: 1, 2, 3, ... + Start at: 1 + Alignment: Left + Aligned at: 0 cm + Tab after: 0 cm + Indent at: 1.6 cm, Tabs: 1.9 cm, List tab + Not at 0 cm + 1.27 cm  
Formatted: Font: Arial  
Formatted: Font: Arial

**14.14.2** A Maximum Allowed Revenue (MAR) defined for these activities and those associated with pre-vesting connections is set by the Authority at the time of the Transmission Owners' price control review for the succeeding price control period. Transmission Network Use of System Charges are set to recover the Maximum Allowed Revenue as set by the Price Control (where necessary, allowing for any K<sub>i</sub> adjustment for under or over recovery in a previous year net of the income recovered through pre-vesting connection charges).

Formatted: Font: 11 pt  
Formatted: Font: Arial  
Formatted: Indent: Left: 1.27 cm, Numbered + Level: 1 + Numbering Style: 1, 2, 3, ... + Start at: 1 + Alignment: Left + Aligned at: 0 cm + Tab after: 0 cm + Indent at: 1.6 cm, Tabs: 1.9 cm, List tab + Not at 0 cm + 1.27 cm

**14.14.3** The basis of charging to recover the allowed revenue is the Investment Cost Related Pricing (ICRP) methodology, which was initially introduced by The Company in 1993/94 for England and Wales. The principles and methods underlying the ICRP methodology were set out in the The Company document "Transmission Use of System Charges Review: Proposed Investment Cost Related Pricing for Use of System (30 June 1992)".

Formatted: Font: Arial  
Formatted: Font: Arial  
Formatted: Font: Arial  
Formatted: Font: Arial

**14.14.4** In December 2003, The Company published the Initial Thoughts consultation for a GB methodology using the England and Wales methodology as the basis for consultation. The Initial Methodologies consultation published by The Company in May 2004 proposed two options for a GB charging methodology with a Final Methodologies consultation published in August 2004 detailing The Company's response to the Industry with a recommendation for the GB charging methodology. In December 2004, The Company published a Revised Proposals consultation in response to the Authority's invitation for further review on certain areas in The Company's recommended GB charging methodology.

Formatted: Indent: Left: 1.27 cm, Numbered + Level: 1 + Numbering Style: 1, 2, 3, ... + Start at: 1 + Alignment: Left + Aligned at: 0 cm + Tab after: 0 cm + Indent at: 1.6 cm, Tabs: 1.9 cm, List tab + Not at 0 cm + 1.27 cm  
Formatted: Font: Arial  
Formatted: Font: Arial  
Formatted: Font: Arial

**14.14.5** In April 2004 The Company introduced a DC Loadflow (DCLF) ICRP based transport model for the England and Wales charging methodology. The DCLF model has been extended to incorporate Scottish network data with existing England and Wales network data to form the GB network in the model. In April 2005, the GB charging methodology implemented the following proposals:

Formatted: Indent: Left: 1.27 cm, Numbered + Level: 1 + Numbering Style: 1, 2, 3, ... + Start at: 1 + Alignment: Left + Aligned at: 0 cm + Tab after: 0 cm + Indent at: 1.6 cm, Tabs: 1.9 cm, List tab + Not at 0 cm + 1.27 cm  
Formatted: Font: Arial  
Formatted: Font: Arial

i.) The application of multi-voltage circuit expansion factors with a forward-looking Expansion Constant that does not include substation costs in its derivation.

Formatted: Font: Arial  
Formatted: Font: Arial  
Formatted: ... [1]  
Formatted: Font: Arial  
Formatted: Font: Arial  
Formatted: ... [2]  
Formatted: Font: Arial

- ii.) The application of locational security costs, by applying a multiplier to the Expansion Constant reflecting the difference in cost incurred on a secure network as opposed to an unsecured network.
- iii.) The application of a de-minimus level demand charge of £0/kW for Half Hourly and £0/kWh for Non Half Hourly metered demand to avoid the introduction of negative demand tariffs.
- iv.) The application of 132kV expansion factor on a Transmission Owner basis reflecting the regional variations in network upgrade plans.
- v.) The application of a Transmission Network Use of System Revenue split between generation and demand of 27% and 73% respectively.
- vi.) The number of generation zones using the criteria outlined in paragraph 14.15.26 has been determined as 21.
- vii.) The number of demand zones has been determined as 14, corresponding to the 14 GSP groups.

14.14.6 The underlying rationale behind Transmission Network Use of System charges is that efficient economic signals are provided to Users when services are priced to reflect the incremental costs of supplying them. Therefore, charges should reflect the impact that Users of the transmission system at different locations would have on the Transmission Owner's costs, if they were to increase or decrease their use of the respective systems. These costs are primarily defined as the investment costs in the transmission system, maintenance of the transmission system and maintaining a system capable of providing a secure bulk supply of energy.

The Transmission Licence requires The Company to operate the National Electricity Transmission System to specified standards. In addition The Company with other transmission licensees are required to plan and develop the National Electricity Transmission System to meet these standards. These requirements mean that the system must conform to a particular Security Standard and capital investment requirements are largely driven by the need to conform to this standard. It is this obligation, which provides the underlying rationale for the ICRP approach, i.e. for any changes in generation and demand on the system, The Company must ensure that it satisfies the requirements of the Security Standard.

14.14.7 The Security Standard identifies requirements on the capacity of component sections of the system given the expected generation and demand at each node, such that demand can be met and generators' output over the course of a year (capped at their Transmission Entry Capacity, TEC) can be accommodated in the most economic and efficient manner. The derivation of the incremental investment costs at different points on the system is therefore determined against the requirements of the system throughout the year. The Security Standard uses an Economy Criterion to assess such requirements. The charging methodology therefore recognises this year round element in its rationale.

14.14.8 The Economy Criterion requires sufficient transmission system capacity to accommodate all types of generation in order to meet varying levels of demand efficiently. This is achieved through a set of deterministic parameters that have been derived from a generic Cost Benefit Analysis (CBA) seeking to identify an appropriate balance between constraint costs and the costs of transmission reinforcements.

- Formatted: Font: Arial
- Formatted: Indent: Left: 2.54 cm, Numbered + Level: 1 + Numbering Style: i, ii, iii, ... + Start at: 1 + Alignment: Left + Aligned at: 1.27 cm + Tab after: 2.54 cm + Indent at: 2.54 cm, Tabs: Not at 1.27 cm + 2.54 cm
- Formatted: Font: Arial
- Formatted: Font: Arial
- Formatted: ... [3]
- Formatted: Font: Arial
- Formatted: Font: Arial
- Formatted: ... [4]
- Formatted: Font: Arial
- Formatted: ... [5]
- Formatted: Font: Arial
- Formatted: Font: Arial
- Formatted: ... [6]
- Formatted: Font: Arial, 11 pt
- Formatted: Font: Arial
- Formatted: Font: Arial
- Formatted: Font: Arial, 11 pt
- Formatted: ... [7]
- Formatted: Font: Arial
- Formatted: ... [8]
- Formatted: ... [9]
- Deleted: Capacities (TECs)
- Formatted: ... [10]
- Deleted: at the time of ... [11]
- Formatted: Highlight
- Formatted: ... [12]
- Deleted: capacity
- Formatted: Highlight
- Deleted: peak
- Formatted: ... [13]
- Formatted: Highlight
- Formatted: ... [14]
- Formatted: Highlight
- Formatted: ... [15]
- Deleted: 14.14.8
- Formatted: ... [16]
- Formatted: ... [17]
- Formatted: Highlight
- Formatted: ... [18]

**14.14.9** The TNUoS charging methodology seeks to reflect these arrangements through the use of an Year Round background in the Transport Model, representative of the Economy Criterion.

**14.14.10** To recognise that various types of generation will have a different impact on incremental investment costs the charging methodology uses a generator's TEC and Boundary Sharing Factors (BSF) when determining Transmission Network Use of System charges relating to the Year Round background. The BSF takes the diversity of the plant mix (i.e. the proportion of low carbon and carbon generation) behind each boundary into account.

**14.14.11** In setting and reviewing these charges The Company has a number of further objectives. These are to:

- offer clarity of principles and transparency of the methodology;
- inform existing Users and potential new entrants with accurate and stable cost messages;
- charge on the basis of services provided and on the basis of incremental rather than average costs, and so promote the optimal use of and investment in the transmission system; and
- be implementable within practical cost parameters and time-scales.

**14.14.12** Condition C13 of The Company's Transmission Licence governs the adjustment to Use of System charges for small generators. Under the condition, The Company is required to reduce TNUoS charges paid by eligible small generators by a designated sum, which will be determined by the Authority. The licence condition describes an adjustment to generator charges for eligible plant, and a consequential change to demand charges to recover any shortfall in revenue. The mechanism for recovery will ensure revenue neutrality over the lifetime of its operation although it does allow for effective under or over recovery within any year. For the avoidance of doubt, Condition C13 does not form part of the Use of System Charging Methodology.

**14.14.13** The Company will typically calculate TNUoS tariffs annually, publishing final tariffs in respect of a Financial Year by the end of the preceding January. However The Company may update the tariffs part way through a Financial Year.

**Formatted:** Highlight

**Formatted:** Numbered + Level: 1 + Numbering Style: 1, 2, 3, ... + Start at: 5 + Alignment: Left + Aligned at: 1.27 cm + Tab after: 1.27 cm + Indent at: 2.87 cm, Tabs: 1.9 cm, List tab + Not at 1.27 cm

**Formatted:** Numbered + Level: 1 + Numbering Style: 1, 2, 3, ... + Start at: 5 + Alignment: Left + Aligned at: 1.27 cm + Tab after: 1.27 cm + Indent at: 2.87 cm, Tabs: 1.9 cm, List tab + Not at 1.27 cm

**Formatted:** Highlight

**Deleted:** Zonal

**Deleted:** Z

**Formatted:** Font: 11 pt, Highlight

**Formatted:** Highlight

**Formatted:** Font: 11 pt, Highlight

**Formatted:** Highlight

**Formatted:** Font: 11 pt, Highlight

**Formatted:** Highlight

**Deleted:** Z

**Formatted:** Font: 11 pt, Highlight

**Deleted:** in each zone

**Formatted:** Highlight

**Formatted:** Font: 11 pt, Highlight

**Formatted:** Highlight

**Formatted:** Numbered + Level: 1 + Numbering Style: 1, 2, 3, ... + Start at: 5 + Alignment: Left + Aligned at: 1.27 cm + Tab after: 1.27 cm + Indent at: 2.87 cm, Tabs: 1.9 cm, List tab + Not at 1.27 cm

**Formatted:** Indent: Left: 2.5 cm, Hanging: 1.29 cm, Bulleted + Level: 1 + Aligned at: 0 cm + Tab after: 0.63 cm + Indent at: 0.63 cm, Tabs: 3.89 cm, List tab + Not at 0.63 cm + 1.27 cm

**Formatted:** Numbered + Level: 1 + Numbering Style: 1, 2, 3, ... + Start at: 12 + Alignment: Left + Aligned at: 1.27 cm + Tab after: 1.27 cm + Indent at: 2.87 cm

**Formatted** ... [19]

## 14.15 Derivation of the Transmission Network Use of System Tariff

**14.15.1** The Transmission Network Use of System (TNUoS) Tariff comprises two separate elements. Firstly, a locationally varying element derived from the DCLF ICRP transport model to reflect the costs of capital investment in, and the maintenance and operation of, a transmission system to provide bulk transport of power to and from different locations. Secondly, a non-locationally varying element related to the provision of residual revenue recovery. The combination of both these elements forms the TNUoS tariff.

**Formatted:** Numbered + Level: 1 + Numbering Style: 1, 2, 3, ... + Start at: 1 + Alignment: Left + Aligned at: 1.27 cm + Tab after: 1.27 cm + Indent at: 2.87 cm, Tabs: 1.9 cm, List tab + Not at 1.27 cm

**14.15.2** For generation TNUoS tariffs the locational element itself is comprised of three separate components. A wider component reflects the costs of the wider network, and the combination of a local substation and a local circuit component reflect the costs of the local network. Accordingly, the wider tariff represents the combined effect of the wider locational tariff component and the residual element; and the local tariff represents the combination of the two local locational tariff components

**Formatted:** Numbered + Level: 1 + Numbering Style: 1, 2, 3, ... + Start at: 1 + Alignment: Left + Aligned at: 1.27 cm + Tab after: 1.27 cm + Indent at: 2.87 cm, Tabs: 1.9 cm, List tab + Not at 1.27 cm

**14.15.3** The process for calculating the TNUoS tariff is described below.

**Deleted:**

**Deleted:** ¶

**Formatted:** Indent: Left: 1.27 cm

### The Transport Model

#### Model Inputs

**14.15.4** The DCLF ICRP transport model calculates the marginal costs of investment in the transmission system which would be required as a consequence of an increase in demand or generation at each connection point or node on the transmission system, based on a study of peak demand conditions using the Year Round generation background on the transmission system. One measure of the investment costs is in terms of MWkm. This is the concept that ICRP uses to calculate marginal costs of investment. Hence, marginal costs are estimated initially in terms of increases or decreases in units of kilometres (km) of the transmission system for a 1 MW injection to the system.

**Formatted:** Numbered + Level: 1 + Numbering Style: 1, 2, 3, ... + Start at: 1 + Alignment: Left + Aligned at: 1.27 cm + Tab after: 1.27 cm + Indent at: 2.87 cm, Tabs: 1.9 cm, List tab + Not at 1.27 cm

**Formatted:** Numbered + Level: 1 + Numbering Style: 1, 2, 3, ... + Start at: 1 + Alignment: Left + Aligned at: 1.27 cm + Tab after: 1.27 cm + Indent at: 2.87 cm, Tabs: 1.9 cm, List tab + Not at 1.27 cm

**14.15.5** The transport model requires a set of inputs representative of the Economy Criterion set out in the Security Standard. These conditions on the transmission system are represented in the Year Round background respectively as follows:

**Formatted:** Highlight

**Formatted:** Font: 11 pt, Highlight

**Formatted:** Highlight

**Formatted:** Font: 11 pt, Highlight

**Formatted:** Highlight

- Nodal generation information per node (TEC, plant type and SQSS scaling factors)
- Nodal demand information
- Transmission circuits between these nodes
- The associated lengths of these routes, the proportion of which is overhead line or cable and the respective voltage level
- The cost ratio of each of 132kV overhead line, 132kV underground cable, 275kV overhead line, 275kV underground cable and 400kV underground cable to 400kV overhead line to give circuit expansion factors
- The cost ratio of each separate sub-sea AC circuit and HVDC circuit to 400kV overhead line to give circuit expansion factors
- 132kV overhead circuit capacity and single/double route construction information is used in the calculation of a generator's local charge.
- Offshore transmission cost and circuit/substation data

**Formatted:** Numbered + Level: 1 + Numbering Style: 1, 2, 3, ... + Start at: 1 + Alignment: Left + Aligned at: 1.27 cm + Tab after: 1.27 cm + Indent at: 2.87 cm, Tabs: 1.9 cm, List tab + Not at 1.27 cm

**Deleted:** peak

**Formatted:** Font: 11 pt, Highlight

**Formatted:** Highlight

**Formatted** ... [20]

**Deleted:** costs

**14.15.6** For a given charging year "t", the nodal generation TEC figure and generation plant types at each node will be based on the Applicable Value for year "t" in the NETS Seven Year Statement in year "t-1" plus updates to the October of year "t-1". The

**Deleted:** Identification of a reference node¶

**Formatted** ... [21]

contracted TECs and generation plant types in the NETS Seven Year Statement include all plant belonging to generators who have a Bilateral Agreement with the TOs. For example, for 2010/11 charges, the nodal generation data is based on the forecast for 2010/11 in the 2009 NETS Seven Year Statement plus any data included in the quarterly updates in October 2009.

- 14.15.7 Scaling factors for different generation plant types are applied on their aggregated capacity for Year Round background. The scaling is either Fixed or Variable (depending on the total demand level) in line with the factors used in the Security Standard, for example as shown in the table below.

Generation Plant Type	Year Round Background
Intermittent	Fixed (70%)
Nuclear & CCS	Fixed (85%)
Interconnectors	Fixed (100%)
Hydro	Variable
Pumped Storage	Fixed (50%)
Peaking	Fixed (0%)
Other (Conventional)	Variable

These scaling factors and generation plant types are set out in the Security Standard. These may be reviewed from time to time. The latest version will be used in the calculation of TNUoS tariffs and is published in the Statement of Use of System Charges

- 14.15.8 National Grid will categorise plant based on the categorisations described in the Security Standard. Peaking plant will include oil and OCGT technologies and Other (Conv.) represents all remaining conventional plant not explicitly stated elsewhere in the tabl. In the event that a power station is made up of more than one technology type, the type of the higher Transmission Entry Capacity (TEC) would apply.

- 14.15.9 Nodal demand data for the transport model will be based upon the GSP demand that Users have forecast to occur at the time of National Grid Peak Average Cold Spell (ACS) Demand for year "t" in the April Seven Year Statement for year "t-1" plus updates to the October of year "t-1".

- 14.15.10 Transmission circuits for charging year "t" will be defined as those with existing wayleaves for the year "t" with the associated lengths based on the circuit lengths indicated for year "t" in the April NETS Seven Year Statement for year "t-1" plus updates to October of year "t-1". If certain circuit information is not explicitly contained in the NETS Seven Year Statement, The Company will use the best information available.

- 14.15.11 The circuit lengths included in the transport model are solely those, which relate to assets defined as 'Use of System' assets.

- 14.15.12 For HVDC circuits, the impedance will be calculated to provide flows based on a ratio of the capacity provided by the HVDC link relative to the capacities on all major transmission system boundaries that it parallels.

- 14.15.13 The transport model employs the use of circuit expansion factors to reflect the difference in cost between (i) AC circuits and HVDC circuits, (ii) underground and sub-sea circuits, (iii) cabled circuits and overhead line circuits, (iv) 132kV and 275kV circuits, (v) 275kV circuits and 400kV circuits, and (vi), uses 400kV overhead line (i.e. the 400kV overhead line expansion factor is 1). As the transport

- Formatted ... [22]
- Formatted ... [23]
- Formatted ... [24]
- Formatted ... [25]
- Formatted ... [26]
- Formatted ... [27]
- Formatted ... [28]
- Formatted ... [29]
- Formatted ... [30]
- Formatted ... [31]
- Formatted ... [32]
- Formatted ... [33]
- Formatted ... [34]
- Formatted ... [35]
- Formatted ... [36]
- Formatted ... [37]
- Formatted ... [38]
- Formatted ... [39]
- Formatted ... [40]
- Formatted ... [41]
- Formatted ... [42]
- Formatted ... [43]
- Formatted ... [44]
- Formatted ... [45]
- Formatted ... [46]
- Formatted ... [47]
- Formatted ... [48]
- Formatted ... [49]
- Formatted ... [50]
- Formatted ... [51]
- Formatted ... [52]
- Formatted ... [53]
- Formatted ... [54]
- Formatted ... [55]
- Formatted ... [56]
- Formatted ... [57]
- Formatted ... [58]
- Formatted ... [59]
- Formatted ... [60]
- Formatted ... [61]
- Formatted ... [62]
- Formatted ... [63]
- Formatted ... [64]
- Formatted ... [65]
- Deleted: routes
- Deleted: routes, (ii)
- Deleted: routes, (iii)
- Deleted: routes
- Deleted: routes
- Deleted: iv

model expresses cost as marginal km (irrespective of cables or overhead lines), some account needs to be made of the fact that investment in these other types of circuit (specifically HVDC and sub-sea cables of various voltages, 400kV underground cable, 275kV overhead line, 275kV underground cable, 132kV overhead line and 132kV underground cable) is more expensive than for 400kV overhead line. This is done by effectively 'expanding' these more expensive circuits by the relevant circuit expansion factor, thereby producing a larger marginal kilometre to reflect the additional cost of investing in these circuits compared to 400kV overhead line. When calculating the local circuit tariff for a generator, alternative 132kV and offshore expansion factors to those used in the remainder of the tariff calculation are applied to the generator's local circuits.

14.15.14 The circuit expansion factors for HVDC circuits and AC subsea cables are determined on a case by case basis using the costs which are specific to the individual projects containing HVDC or AC subsea circuits.

**Model Outputs**

14.15.15 The transport model takes the inputs described above and scales the TEC of the relevant generation plant types by a percentage as described in 14.15.7, above. The TEC of the remaining generation plant types are uniformly scaled such that total national generation (scaled sum of contracted TECs) equals total national ACS Demand.

14.15.16 The model then uses a DCLF ICRP transport algorithm to derive the resultant pattern of flows based on the network impedance required to meet the nodal demand using the scaled nodal generation, assuming every circuit has infinite capacity. Then it calculates the resultant total network MWkm, using the relevant circuit expansion factors as appropriate.

14.15.17 Using this baseline network, the model then calculates for a given injection of 1MW of generation at each node, with a corresponding 1MW offtake (demand) distributed across all demand nodes in the network, the increase or decrease in total MWkm of the whole network. The proportion of the 1MW offtake allocated to any given demand node will be based on total background nodal demand in the model. For example, with a total GB demand of 60GW in the model, a node with a demand of 600MW would contain 1% of the offtake i.e. 0.01MW.

14.15.18 Given the assumption of a 1MW injection, for simplicity the marginal costs are expressed solely in km. This gives a marginal km cost for generation at each node (although not that used to calculate generation tariffs which considers local and wider cost components). The marginal km cost for demand at each node is equal and opposite to this nodal marginal km for generation and this is used to calculate demand tariffs. Note the marginal km costs can be positive or negative depending on the impact the injection of 1MW of generation has on the total circuit km.

14.15.19 Using a similar methodology as described above in 14.15.17, the local and wider marginal km costs used to determine generation TNUoS tariffs are calculated by injecting 1MW of generation against the node(s) the generator is modelled at and increasing by 1MW the offtake across the distributed reference node.

14.15.20 In addition, any circuits in the model, identified as local assets to a node will have the local circuit expansion factors which are applied in calculating that particular node's marginal km. Any remaining circuits will have the TO specific wider circuit expansion factors applied.

**Formatted:** Indent: Left: 1.9 cm

**Deleted:** A reference node is required as a

**Formatted:** Indent: Left: 1.9 cm, Numbered + Level: 1 + Numbering Style: 1, 2, 3, ... + Start at: 1 + Alignment: Left + Aligned at: 1.27 cm + Tab after: 1.27 cm + Indent at: 2.87 cm, Tabs: 1.9 cm, List tab + Not at 1.27 cm

**Deleted:** point for

**Deleted:** calculation of marginal

**Deleted:** . It determines the magnitude of the marginal costs but not the relativity. For example, if the reference point were put in

**Deleted:** North of Scotland, all nodal generation marginal ... [66]

**Deleted:** ¶

**Formatted:** Font: Arial

**Formatted** ... [67]

**Formatted** ... [68]

**Formatted** ... [69]

**Deleted:** firstly

**Deleted:**

**Deleted:** capacity

**Deleted:** The

**Formatted** ... [70]

**Formatted** ... [71]

**Formatted** ... [72]

**Deleted:** this

**Deleted:** ,

**Deleted:** at the reference node,

**Deleted:** network.

**Formatted** ... [73]

**Deleted:**

**Deleted:**

**Deleted:** ¶ ... [74]

**Formatted** ... [75]

**Formatted** ... [76]

**Formatted** ... [77]

**Formatted:** Highlight

**Formatted** ... [78]

**Deleted:** <#>¶

**Formatted** ... [79]

**Deleted:** at

**Deleted:**

**Formatted** ... [80]

**Formatted** ... [81]

**Deleted:** this model,

**Formatted** ... [82]



[14.15.21](#) An example is contained in 14.21 Transport Model Example.

### Calculation of local nodal marginal km

[14.15.22](#) In order to ensure assets local to generation are charged in a cost reflective manner, a generation local circuit tariff is calculated. The nodal specific charge provides a financial signal reflecting the security and construction of the infrastructure circuits that connect the node to the transmission system.

14.15.23 Main Interconnected Transmission System (MITS) nodes are defined as:

- [Grid Supply Point](#) connections with 2 or more transmission circuits connecting at the site, or
- [connections](#) with more than 4 transmission circuits connecting at the site.

14.15.24 Where a Grid Supply Point is defined as a point of supply from the National Electricity Transmission System to network operators or non-embedded customers excluding generator or interconnector load alone. For the avoidance of doubt, generator or interconnector load would be subject to the circuit component of its Local Charge. A transmission circuit is part of the National Electricity Transmission System between two or more circuit-breakers which includes transformers, cables and overhead lines but excludes busbars and generation circuits.

[14.15.25](#) Generators directly connected to a MITS node will have a zero local circuit tariff.

[14.15.26](#) Generators not connected to a MITS node will have a local circuit tariff derived from the local nodal marginal km for the generation node i.e. the increase or decrease in marginal km along the transmission circuits connecting it to all adjacent MITS nodes (local assets).

### Calculation of zonal marginal km

[14.15.27](#) Given the requirement for relatively stable cost messages through the ICRP methodology and administrative simplicity, nodes are assigned to zones. Typically, generation zones will be reviewed at the beginning of each price control period with another review only undertaken in exceptional circumstances. Any rezoning required during a price control period will be undertaken with the intention of minimal disruption to the established zonal boundaries. The full criteria for determining generation zones are outlined in paragraph 14.15.32. The number of generation zones set for 2010/11 is 20.

[14.15.28](#) Demand zone boundaries have been fixed and relate to the GSP Groups used for energy market settlement purposes.

[14.15.29](#) The nodal marginal km are amalgamated into zones by weighting them by their relevant generation or demand capacity.

14.15.30 Generators will have a zonal tariff derived from the wider nodal marginal km for the generation node, calculated as the increase or decrease in marginal km along all transmission circuits except those classified as local assets. The zonal marginal km for generation is calculated as:

**Formatted:** Indent: Left: 1.9 cm, Numbered + Level: 1 + Numbering Style: 1, 2, 3, ... + Start at: 1 + Alignment: Left + Aligned at: 1.27 cm + Tab after: 1.27 cm + Indent at: 2.87 cm, Tabs: 1.9 cm, List tab + Not at: 1.27 cm

**Formatted:** Indent: Left: 0.63 cm

**Formatted:** Indent: Left: 1.9 cm, Numbered + Level: 1 + Numbering Style: 1, 2, 3, ... + Start at: 1 + Alignment: Left + Aligned at: 1.27 cm + Tab after: 1.27 cm + Indent at: 2.87 cm, Tabs: 1.9 cm, List tab + Not at: 1.27 cm

**Formatted:** Justified, Indent: Left: 1.9 cm

**Formatted:** Indent: Left: 1.9 cm, Bulleted + Level: 1 + Aligned at: 0 cm + Tab after: 0.63 cm + Indent at: 0.63 cm, Tabs: 2.54 cm, List tab + Not at: 0.63 cm + 1.27 cm

**Formatted:** Numbered + Level: 1 + Numbering Style: 1, 2, 3, ... + Start at: 1 + Alignment: Left + Aligned at: 1.27 cm + Tab after: 1.27 cm + Indent at: 2.87 cm

**Formatted:** Numbered + Level: 1 + Numbering Style: 1, 2, 3, ... + Start at: 1 + Alignment: Left + Aligned at: 1.27 cm + Tab after: 1.27 cm + Indent at: 2.87 cm

**Formatted:** Indent: Left: 0.63 cm

**Formatted:** Bullets and Numbering

**Deleted:** 26

**Formatted:** Bullets and Numbering

**Formatted:** Bullets and Numbering

**Deleted:**

**Deleted:** ¶

$$WNMkm_j = \frac{NMkm_j * Gen_j}{\sum_{j \in Gi} Gen_j}$$

$$ZIMkm_{Gi} = \sum_{j \in Gi} WNMkm_j$$

Where  
 Gi = Generation zone  
 j = Node  
 NMkm = Wider nodal marginal km from transport model  
 WNMkm = Weighted nodal marginal km  
 ZMkm = Zonal Marginal km  
 Gen = Nodal Generation from the transport model

14.15.31 The zonal marginal km for demand zones are calculated as follows:

$$WNMkm_j = \frac{-1 * NMkm_j * Dem_j}{\sum_{j \in Di} Dem_j}$$

$$ZMkm_{Di} = \sum_{j \in Di} WNMkm_j$$

Where  
 Di = Demand zone  
 Dem = Nodal Demand from transport model

14.15.32 A number of criteria are used to determine the definition of the generation zones. Whilst it is the intention of The Company that zones are fixed for the duration of a price control period, it may become necessary in exceptional circumstances to review the boundaries having been set. In both circumstances, the following criteria are used to determine the zonal boundaries:

- i.) Zones should contain relevant nodes whose wider marginal costs (as determined from the output from the transport model, the relevant expansion constant and the locational security factor, see below) are all within +/-£1.00/kW (nominal prices) across the zone. This means a maximum spread of £2.00/kW in nominal prices across the zone.
- ii.) The nodes within zones should be geographically and electrically proximate.
- iii.) Relevant nodes are considered to be those with generation connected to them as these are the only ones, which contribute to the calculation of the zonal generation tariff.

14.15.33 The process behind the criteria in 14.15.32 is driven by initially applying the nodal marginal costs from the DCLF Transport model onto the appropriate areas of a substation line diagram. Generation nodes are grouped into initial zones using the +/-£1.00/kW range. All nodes within each zone are then checked to ensure the geographically and electrically proximate criteria have been met using the substation line diagram. The established zones are inspected to ensure the least number of zones are used with minimal change from previously established zonal boundaries. The zonal boundaries are finally confirmed using the demand nodal costs for guidance.

Deleted: ¶

Deleted:  $ZMkm_{Gi} = \sum_{j \in Gi} WNMkm_j$

Deleted: . . .

Deleted: . = .

Deleted: IM

Deleted: . = .

Formatted: Font: Arial (W1), 11 pt, Highlight

Deleted: M

Deleted: Initial

Formatted: Highlight

Formatted: Font: Arial (W1), 11 pt, Highlight

Formatted: Highlight

Formatted: Font: Arial (W1), 11 pt, Highlight

Formatted: Font: Arial (W1), 11 pt, Highlight

Deleted: . . .

Deleted: (scaled by the appropriate Scaling factor)

Formatted: Indent: Left: 1.27 cm, Hanging: 3.81 cm

Deleted: The

Formatted: Bullets and Numbering

Formatted: Justified

Formatted: Font: Arial (W1), 11 pt

Formatted: Justified, Indent: Left: 3.81 cm

Deleted: ¶

Formatted: Indent: Left: 1.27 cm, First line: 0 cm

Deleted: ¶

Formatted: Bullets and Numbering

Formatted: Indent: Left: 2.75 cm, Numbered + Level: 1 + Numbering Style: i, ii, iii, ... + Start at: 1 + Alignment: Left + Aligned at: 0 cm + Tab after: 1.27 cm + Indent at: 0 cm, Tabs: 3.6 cm, List tab + Not at 1.27 cm

Formatted: Indent: Left: 2.75 cm

Formatted: ... [83]

Formatted: ... [84]

Formatted: ... [85]

Formatted: Bullets and Numbering ... [86]

Deleted: 26

14.15.34 The zoning criteria are applied to a reasonable range of DCLF ICRP transport model scenarios, the inputs to which are determined by The Company to create appropriate TNUoS generation zones. The minimum number of zones, which meet the stated criteria, are used. If there is more than one feasible zonal definition of a certain number of zones, The Company determines and uses the one that best reflects the physical system boundaries.

Formatted: Bullets and Numbering

14.15.35 Zones will typically not be reviewed more frequently than once every price control period to provide some stability. However, in exceptional circumstances, it may be necessary to review zoning more frequently to maintain appropriate, cost reflective, locational cost signals. For example, if a new generator connecting to the transmission system would cause the creation of a new generation zone for that generator alone, it may not be appropriate from a cost reflective perspective to wait until the next price control period to undertake this rezoning. If any such rezoning is required, it will be undertaken against a background of minimal change to existing generation zones and in line with the notification process set out in the Transmission Licence and CUSC.

Formatted: Bullets and Numbering

**Accounting for Sharing of Transmission by Generators**

14.15.36 A proportion of the marginal km costs for generation are shared incremental km reflecting the ability of differing generation technologies to share transmission investment. This is reflected in charges through consideration of not-shared zonal incremental km in the calculation of the wider £/kW generation tariff.

Formatted: Font: 11 pt, Highlight

14.15.37 The sharing between different generation types is accounted for by (a) using transmission network boundaries between generation zones set by connectivity between generation charging zones, and (b) the proportion of Low Carbon and Carbon generation behind these boundaries.

Formatted: Indent: Left: 1.9 cm, Numbered + Level: 1 + Numbering Style: 1, 2, 3, ... + Start at: 1 + Alignment: Left + Aligned at: 1.27 cm + Tab after: 1.27 cm + Indent at: 2.87 cm, Tabs: 1.9 cm, List tab + Not at 1.27 cm

14.15.38 The zonal incremental km for each generation charging zone is split into each boundary component by considering the difference between it and the neighbouring generation charging zone using the formula below:

Formatted: Indent: Left: 1.9 cm, Numbered + Level: 1 + Numbering Style: 1, 2, 3, ... + Start at: 1 + Alignment: Left + Aligned at: 1.27 cm + Tab after: 1.27 cm + Indent at: 2.87 cm, Tabs: 1.9 cm, List tab + Not at 1.27 cm

$$BIkm_{ab} = ZIkm_b - ZIkm_a$$

Where:

BIkm<sub>ab</sub> = boundary incremental km between generation charging zone A and generation charging zone B

ZIkm = generation charging zone incremental km

Formatted: Indent: Left: 1.9 cm, Hanging: 1.69 cm, Numbered + Level: 1 + Numbering Style: 1, 2, 3, ... + Start at: 1 + Alignment: Left + Aligned at: 1.27 cm + Tab after: 1.27 cm + Indent at: 2.87 cm, Tabs: 1.69 cm, List tab + Not at 1.27 cm

14.15.39 The table below shows the categorisation of Low Carbon and Carbon generation. This table will be updated by National Grid in the Statement of Use of System Charges as new generation technologies are developed.

Formatted: Indent: Left: 1.9 cm, Hanging: 1.69 cm, Numbered + Level: 1 + Numbering Style: 1, 2, 3, ... + Start at: 1 + Alignment: Left + Aligned at: 1.27 cm + Tab after: 1.27 cm + Indent at: 2.87 cm

Carbon	Low Carbon
Coal	Wind
Gas	Hydro (excl. Pumped Storage)
Biomass	Nuclear
Oil	Marine
Pumped Storage	Tidal
Interconnectors	

Formatted: Indent: Left: 1.9 cm

**Determination of Connectivity**

14.15.40 Connectivity is based on the existence of electrical circuits between TNUoS generation charging zones that are represented in the Transport model. Where such paths exist, generation charging zones will be effectively linked via an incremental km transmission boundary length. These paths will be simplified through in the case of:

**Formatted:** Indent: Left: 1.9 cm, Numbered + Level: 1 + Numbering Style: 1, 2, 3, ... + Start at: 1 + Alignment: Left + Aligned at: 1.27 cm + Tab after: 1.27 cm + Indent at: 2.87 cm, Tabs: 1.69 cm, List tab + Not at 1.27 cm

- Parallel paths – the longest path will be taken. An illustrative example is shown below with x, y and z representing the incremental km between zones.

**Formatted:** Indent: Left: 1.9 cm, Bulleted + Level: 1 + Aligned at: 0 cm + Tab after: 0.63 cm + Indent at: 0.63 cm, Tabs: 2.54 cm, List tab + Not at 0.63 cm + 1.27 cm

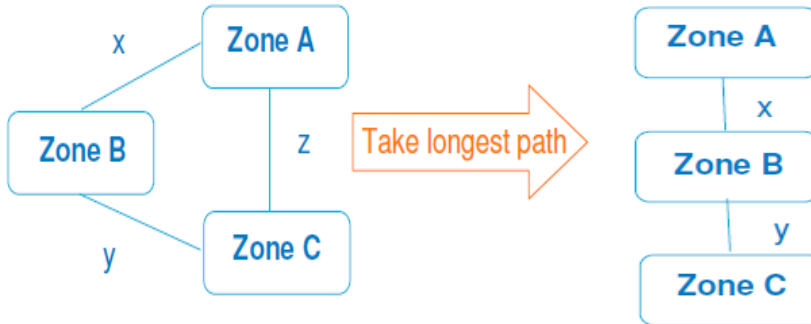

- Parallel zones – parallel zones will be amalgamated with the incremental km immediately beyond the amalgamated zones being the greater of those existing prior to the amalgamation. An illustrative example is shown below with a, b, c, and d representing the the initial incremental km between zones, and x and y representing the final incremental km following zonal amalgamation.

**Formatted:** Indent: Left: 1.9 cm, Bulleted + Level: 1 + Aligned at: 0 cm + Tab after: 0.63 cm + Indent at: 0.63 cm, Tabs: 2.54 cm, List tab + Not at 0.63 cm + 1.27 cm

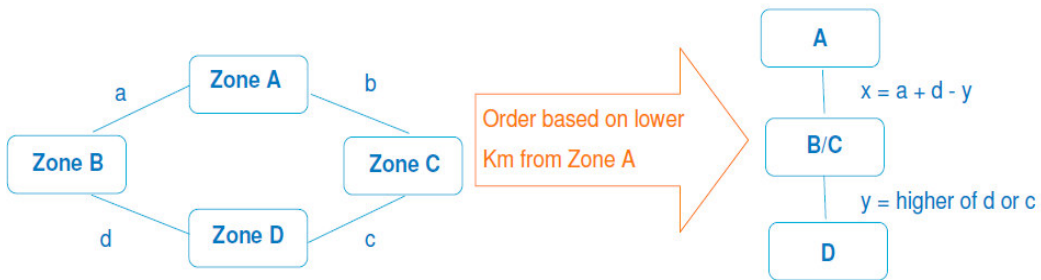

14.15.41 An illustrative Connectivity diagram is shown below:

**Formatted:** Indent: Left: 1.9 cm, Numbered + Level: 1 + Numbering Style: 1, 2, 3, ... + Start at: 1 + Alignment: Left + Aligned at: 1.27 cm + Tab after: 1.27 cm + Indent at: 2.87 cm, Tabs: 1.69 cm, List tab + Not at 1.27 cm



The arrows connecting generation charging zones and amalgamated generation charging zones represent the incremental km transmission boundary lengths towards the notional centre of the system. Generation located in zones behind arrows is considered to share based on the ratio of Low Carbon to Carbon cumulative generation TEC within those zones.

14.15.42 The Company will review Connectivity at the beginning of a new price control period, and under exceptional circumstances such as major system reconfigurations or generation rezoning. If any such reassessment is required, it will be undertaken against a background of minimal change to existing Connectivity and in line with the notification process set out in the Transmission Licence and the CUSC.

**Formatted:** Indent: Left: 1.9 cm, Hanging: 1.69 cm, Numbered + Level: 1 + Numbering Style: 1, 2, 3, ... + Start at: 1 + Alignment: Left + Aligned at: 1.27 cm + Tab after: 1.27 cm + Indent at: 2.87 cm, Tabs: 1.69 cm, List tab + Not at 1.27 cm

**Calculation of Boundary Sharing Factors**

14.15.43 Boundary sharing factors are derived from the comparison of the cumulative proportion of Low Carbon and Carbon generation TEC behind each of the incremental MWkm boundary lengths using the following formula:

**Formatted:** Bullets and Numbering

$$BSF = \text{Minimum} \left( \frac{LC}{LC + C}, \frac{C}{LC + C} \right)$$

Where:

BSF = Boundary Sharing Factor

LC = Cumulative Low carbon generation TEC behind the relevant transmission boundary

C = Cumulative Carbon generation TEC behind the relevant transmission boundary

14.15.44 The shared incremental km for each boundary are derived from the multiplication of the boundary sharing factor by the incremental km for that boundary:

**Formatted:** Indent: Left: 1.27 cm

**Formatted:** Bullets and Numbering

$$SBIkm_{ab} = BIIkm_{ab} \times BSF_{ab}$$

Where:

$SBIkm_{ab}$  = shared boundary incremental km between generation charging zone A and generation charging zone B

$BSF_{ab}$  = generation charging zone boundary sharing factor

14.15.45 The shared incremental km is discounted from the incremental km for that boundary to establish the not-shared boundary incremental km. The not-shared boundary incremental km reflects the cost of transmission investment on that boundary accounting for the sharing of power stations behind that boundary.

$$NSBIkm_{ab} = BIm_{ab} - SBIkm_{ab}$$

Where:

$NSBIkm_{ab}$  = not shared boundary incremental km between generation charging zone A and generation charging zone B

14.15.46 The not-shared incremental km for a generation zone is the sum of the appropriate not-shared boundary incremental km for that generation zone as derived from the connectivity diagram.

$$\sum_a^n NSBIkm_{ab} = ZSBIkm_n$$

Where:

$ZSBIkm_n$  = not-shared zonal incremental for generation charging zone n

### Deriving the Final Local £/kW Tariff and the Wider £/kW Tariff

14.15.47 The not-shared zonal marginal km ( $ZMkm_{Gi}$ ) are converted into costs and hence a tariff by multiplying by the **Expansion Constant** and the **Locational Security Factor** (see below). The nodal local marginal km ( $NLMkm^L$ ) are converted into costs and hence a tariff by multiplying by the **Expansion Constant** and a **Local Security Factor**.

### The Expansion Constant

14.15.48 The expansion constant, expressed in £/MWkm, represents the annuitised value of the transmission infrastructure capital investment required to transport 1 MW over 1 km. Its magnitude is derived from the projected cost of 400kV overhead line, including an estimate of the cost of capital, to provide for future system expansion.

14.15.49 In the methodology, the expansion constant is used to convert the marginal km figure derived from the transport model into a £/MW signal. The tariff model performs this calculation, in accordance with 14.15.80 – 14.15.83, and also then calculates the residual element of the overall tariff (to ensure correct revenue recovery in accordance with the price control), in accordance with 14.15.99.

14.15.50 The transmission infrastructure capital costs used in the calculation of the expansion constant are provided via an externally audited process. They also include information provided from all onshore Transmission Owners (TOs). They are based on historic costs and tender valuations adjusted by a number of indices (e.g. global price of steel, labour, inflation, etc.). The objective of these adjustments is to make the costs reflect current prices, making the tariffs as forward looking as possible. This cost data represents The Company's best view; however it is considered as commercially sensitive and is therefore treated as confidential. The calculation of the expansion constant also relies on a significant amount of transmission asset information, much of which is provided in the Seven Year Statement.

Formatted: Indent: Left: 1.27 cm

Formatted: Bullets and Numbering

Formatted: Indent: Left: 1.27 cm

Formatted: Indent: Left: 1.27 cm

Formatted: Bullets and Numbering

Formatted: Indent: Left: 1.27 cm

Formatted: Centered

Formatted: Left, Indent: Left: 3.6 cm

Formatted: Font: 11 pt, Highlight

Formatted: Bullets and Numbering

Formatted: Font: 11 pt, Highlight

Formatted: Bullets and Numbering

Formatted: Bullets and Numbering

Deleted: 60

Deleted: 65

Deleted: 81

Formatted: Bullets and Numbering

**14.15.51** For each circuit type and voltage used onshore, an individual calculation is carried out to establish a £/MWkm figure, normalised against the 400KV overhead line (OHL) figure, these provide the basis of the onshore circuit expansion factors discussed in 14.15.59 – 14.15.66. In order to simplify the calculation a unity power factor is assumed, converting £/MVAkm to £/MWkm. This reflects that the fact tariffs and charges are based on real power.

Formatted: Bullets and Numbering

Deleted: 42...47 [87]

**14.15.52** The table below shows the first stage in calculating the onshore expansion constant. A range of overhead line types is used and the types are weighted by recent usage on the transmission system. This is a simplified calculation for 400kV OHL using example data:

Formatted: Bullets and Numbering

400kV OHL expansion constant calculation					
MW	Type	£(000)/km	Circuit km*	£/MWkm	Weight
A	B	C	D	E = C/A	F=E*D
6500	La	700	500	107.69	53846
6500	Lb	780	0	120.00	0
3500	La/b	600	200	171.43	34286
3600	Lc	400	300	111.11	33333
4000	Lc/a	450	1100	112.50	123750
5000	Ld	500	300	100.00	30000
5400	Ld/a	550	100	101.85	10185
Sum			2500 (G)	285400 (H)	
				Weighted Average (J= H/G):	114.160 (J)

Formatted: Font: 11 pt

Formatted [88]

Formatted [89]

Formatted [90]

Formatted [91]

Formatted [92]

Formatted [93]

Formatted [94]

Formatted [95]

Formatted [96]

\*These are circuit km of types that have been provided in the previous 10 years. If no information is available for a particular category the best forecast will be used.

Formatted: Font: 11 pt

Formatted: Font: 11 pt

Formatted: Font: 11 pt

Formatted: Font: 11 pt

Formatted: Font: 11 pt

Formatted: Font: 11 pt

Formatted: Font: 11 pt

Formatted: Font: 11 pt

Formatted: Font: 11 pt

Formatted: Font: 11 pt

Formatted: Font: 11 pt

Formatted: Font: 11 pt

Formatted: Font: 11 pt

Formatted: Font: 11 pt

Formatted: Font: 11 pt

Formatted: Font: 11 pt

Formatted: Font: 11 pt

Formatted: Font: 11 pt

Formatted: Font: 11 pt

Formatted: Font: 11 pt

Formatted: Font: 11 pt

Formatted: Font: 11 pt

Formatted: Font: 11 pt

Formatted: Font: 11 pt

Formatted: Font: 11 pt

Formatted: Font: 11 pt

Formatted: Font: 11 pt

Formatted: Font: 11 pt

Formatted: Font: 11 pt

Formatted: Font: 11 pt

Formatted: Font: 11 pt

Formatted: Font: 11 pt

Formatted: Font: 11 pt

Formatted: Font: 11 pt

Formatted: Font: 11 pt

**14.15.53** The weighted average £/MWkm (J in the example above) is then converted in to an annual figure by multiplying it by an annuity factor. The formula used to calculate of the annuity factor is shown below:

$$Annuity\ factor = \frac{1}{\left[ \frac{1 - (1 + WACC)^{-AssetLife}}{WACC} \right]}$$

Formatted: Bullets and Numbering

**14.15.54** The Weighted Average Cost of Capital (WACC) and asset life are established at the start of a price control and remain constant throughout a price control period. The WACC used in the calculation of the annuity factor is the The Company regulated rate of return, this assumes that it will be reasonably representative of all licensees. The asset life used in the calculation is 50 years; the appropriateness of this is reviewed when the annuity factor is recalculated at the start of a price control period. These assumptions provide a current annuity factor of 0.066.

Formatted: Bullets and Numbering

**14.15.55** The final step in calculating the expansion constant is to add a share of the annual transmission overheads (maintenance, rates etc). This is done by multiplying the average weighted cost (J) by an 'overhead factor'. The 'overhead factor' represents the total business overhead in any year divided by the total Gross Asset Value (GAV) of

Formatted: Bullets and Numbering

the transmission system. This is recalculated at the start of each price control period. The overhead factor used in the calculation of the expansion constant for 2009/10 is 1.8%. The overhead and annuitised costs are then added to give the expansion constant.

**14.15.56** Using the previous example, the final steps in establishing the expansion constant are demonstrated below:

**Formatted:** Bullets and Numbering

<b>400kV OHL expansion constant calculation</b>	<b>Ave £/MWkm</b>
<b>OHL</b>	114.160
Annuitised	7.535
Overhead	2.055
<b>Final</b>	<b>9.589</b>

**14.15.57** This process is carried out for each voltage onshore, along with other adjustments to take account of upgrade options, see 14.15.62, and normalised against the 400KV overhead line cost (the expansion constant) the resulting ratios provide the basis of the onshore expansion factors. The process used to derive circuit expansion factors for Offshore Transmission Owner networks is described in 14.15.50.

**Formatted:** Bullets and Numbering

**Deleted:** 45

**14.15.58** This process of calculating the incremental cost of capacity for a 400kV OHL, along with calculating the onshore expansion factors is carried out for the first year of the price control and is increased by inflation, RPI, (May–October average increase, as defined in The Company’s Transmission Licence) each subsequent year of the price control period. The expansion constant for 2010/11 is 10.633.

**Formatted:** Bullets and Numbering

**Onshore Wider Circuit Expansion Factors**

**14.15.59** Base onshore expansion factors are calculated by deriving individual expansion constants for the various types of circuit, following the same principles used to calculate the 400kV overhead line expansion constant. The factors are then derived by dividing the calculated expansion constant by the 400kV overhead line expansion constant. The factors will be fixed for each respective price control period.

**Formatted:** Bullets and Numbering

**14.15.60** In calculating the onshore underground cable factors, the forecast costs are weighted equally between urban and rural installation, and direct burial has been assumed. The operating costs for cable are aligned with those for overhead line. An allowance for overhead costs has also been included in the calculations.

**Formatted:** Bullets and Numbering

**14.15.61** The 132kV onshore circuit expansion factor is applied on a TO basis. This is to reflect the regional variation of plans to rebuild circuits at a lower voltage capacity to 400kV. The 132kV cable and line factor is calculated on the proportion of 132kV circuits likely to be uprated to 400kV. The 132kV expansion factor is then calculated by weighting the 132kV cable and overhead line costs with the relevant 400kV expansion factor, based on the proportion of 132kV circuitry to be uprated to 400kV. For example, in the TO areas of National Grid and Scottish Power where there are no plans to uprate any 132kV circuits, the full cable and overhead line costs of 132kV circuit are reflected in the 132kV expansion factor calculation.

**Formatted:** Bullets and Numbering

**14.15.62** The 275kV onshore circuit expansion factor is applied on a GB basis and includes a weighting of 83% of the relevant 400kV cable and overhead line factor. This is to reflect the averaged proportion of circuits across all three Transmission Licensees which are likely to be uprated from 275kV to 400kV across GB within a price control period.

**Formatted:** Bullets and Numbering



**14.15.63** The 400kV onshore circuit expansion factor is applied on a GB basis and reflects the full costs for 400kV cable and overhead lines.

**Formatted:** Bullets and Numbering

**14.15.64** AC sub-sea cable and HVDC circuit expansion factors are calculated on a case by case basis using actual project costs (Specific Circuit Expansion Factors).

**Formatted:** Bullets and Numbering

**14.15.65** For HVDC circuit expansion factors both the cost of the converters and the cost of the cable are included in the calculation.

**Formatted:** Bullets and Numbering

**14.15.66** The TO specific onshore circuit expansion factors calculated for 2008/9 (and rounded to 2 decimal places) are:

**Deleted:** ¶

**Formatted:** Bullets and Numbering

Scottish Hydro Region

400kV <u>underground</u> cable factor:	22.39
275kV <u>underground</u> cable factor:	22.39
132kV <u>underground</u> cable factor:	27.79
400kV line factor:	1.00
275kV line factor:	1.14
132kV line factor:	2.24

Scottish Power & National Grid Regions

400kV <u>underground</u> cable factor:	22.39
275kV <u>underground</u> cable factor:	22.39
132kV <u>underground</u> cable factor:	30.22
400kV line factor:	1.00
275kV line factor:	1.14
132kV line factor:	2.80

**Onshore Local Circuit Expansion Factors**

**14.15.67** The local onshore circuit tariff is calculated using local onshore circuit expansion factors. These expansion factors are calculated using the same methodology as the onshore wider expansion factor but without taking into account the proportion of circuit kms that are planned to be updated.

**Formatted:** Bullets and Numbering

**14.15.68** In addition, the 132kV onshore overhead line circuit expansion factor is sub divided into four more specific expansion factors. This is based upon maximum (winter) circuit continuous rating (MVA) and route construction whether double or single circuit.

**Formatted:** Bullets and Numbering

400kV <u>underground</u> cable factor:	22.39
275kV <u>underground</u> cable factor:	22.39
132kV <u>underground</u> cable factor:	30.22
400kV line factor:	1.00
275kV line factor:	1.14
132kV line factor (single; <200MVA):	10.00
132kV line factor (double; <200MVA):	8.32
132kV line factor (single; >=200MVA):	7.13
132kV line factor (double; >=200MVA):	4.42

**Offshore Circuit Expansion Factors**

**14.15.69** Offshore expansion factors (£/MWkm) are derived from information provided by Offshore Transmission Owners for each offshore circuit. Offshore expansion factors

**Formatted:** Bullets and Numbering

are Offshore Transmission Owner and circuit specific. Each Offshore Transmission Owner will periodically provide, via the STC, information to derive an annual circuit revenue requirement. The offshore circuit revenue shall include revenues associated with the Offshore Transmission Owner’s reactive compensation equipment, harmonic filtering equipment, asset spares and HVDC converter stations.

**14.15.70** In the first year of connection, the offshore circuit expansion factor would be calculated as follows:

**Formatted:** Bullets and Numbering

$$\frac{CRevOFTO1}{L \times CircRat} \div \text{Onshore 400kV OHL Expansion Constant}$$

Where:

CRevOFTO1 = The offshore circuit revenue in £ for Year 1  
 L = The total circuit length in km of the offshore circuit  
 CircRat = The continuous rating of the offshore circuit

**14.15.71** In all subsequent years, the offshore circuit expansion factor would be calculated as follows:

**Formatted:** Bullets and Numbering

$$\frac{AvCRevOFTO}{L \times CircRat} \div \text{Onshore 400kV OHL Expansion Constant}$$

Where:

AvCRevOFTO = The annual offshore circuit revenue averaged over the remaining years of the onshore National Electricity Transmission System Operator (NETSO) price control  
 L = The total circuit length in km of the offshore circuit  
 CircRat = The continuous rating of the offshore circuit

**14.15.72** Prevailing OFFSHORE TRANSMISSION OWNER specific expansion factors will be published in this statement. These shall be re-calculated at the start of each price control when the onshore expansion constants are revisited.

**Formatted:** Bullets and Numbering

### The Locational Onshore Security Factor

**Formatted:** 1,2,3, Indent: First line: 0 cm

**14.15.73** The locational onshore security factor is derived by running a secure DCLF ICRP transport study based on the same market background as used for Zoning in the DCLF ICRP transport model. This calculates the nodal marginal costs where peak demand can be met despite the Security and Quality of Supply Standard contingencies (simulating single and double circuit faults) on the network. Essentially the calculation of secured nodal marginal costs is identical to the process outlined above except that the secure DCLF study additionally calculates a nodal marginal cost taking into account the requirement to be secure against a set of worse case contingencies in terms of maximum flow for each circuit.

**Formatted:** Bullets and Numbering

**14.15.74** The secured nodal cost differential is compared to that produced by the DCLF ICRP transport model and the resultant ratio of the two determines the locational security factor using the Least Squares Fit method. Further information may be obtained from the charging website<sup>1</sup>.

**Formatted:** Bullets and Numbering

**14.15.75** The locational onshore security factor derived for 2010/11 is 1.8 and is based on an average from a number of studies conducted by The Company to account for future

**Formatted:** Bullets and Numbering

<sup>1</sup> <http://www.nationalgrid.com/uk/Electricity/Charges/>

network developments. The security factor is reviewed for each price control period and fixed for the duration.

**Local Security Factors**

**14.15.76** Local onshore security factors are generator specific and are applied to a generators local onshore circuits. If the loss of any one of the local circuits prevents the export of power from the generator to the MITS then a local security factor of 1.0 is applied. For generation with circuit redundancy, a local security factor is applied that is equal to the locational security factor, currently 1.8.

Formatted: Bullets and Numbering

**14.15.77** Where a Transmission Owner has designed a local onshore circuit (or otherwise that circuit once built) to a capacity lower than the aggregated TEC of the generation using that circuit, then the local security factor of 1.0 will be multiplied by a Counter Correlation Factor (CCF) as described in the formula below:

Formatted: Bullets and Numbering

$$CCF = \frac{D_{min} + T_{cap}}{G_{cap}}$$

Where:  $D_{min}$  = minimum annual net demand (MW) supplied via that circuit in the absence of that generation using the circuit

$T_{cap}$  = transmission capacity built (MVA)

$G_{cap}$  = aggregated TEC of generation using that circuit

CCF cannot be greater than 1.0.

**14.15.78** A specific offshore local security factor (LocalSF) will be calculated for each offshore connection using the following methodology:

Formatted: Bullets and Numbering

$$LocalSF = \frac{NetworkExportCapacity}{\sum_k Gen_k}$$

Where:

NetworkExportCapacity = the total export capacity of the network  
 k = the generation connected to the offshore network

**14.15.79** The offshore security factor for single circuits with a single cable will be 1.0 and for multiple circuit connections will be capped at the locational onshore security factor, derived as 1.8 for 2010/11.

Formatted: Bullets and Numbering

Formatted: Indent: Left: 1.27 cm

Formatted: Bullets and Numbering

Deleted: ¶

Formatted: Font: 11 pt, Highlight

Formatted: Highlight

Deleted: ¶

$$ZMkm_{Gi} \times EC \times LSF = ITT_{Gi}$$

Formatted: Highlight

Formatted: Centered

Formatted: Highlight

Formatted: Highlight

**Initial Transport Tariff**

**14.15.80** First an Initial Transport Tariff (ITT) must be calculated. For Generation<sub>i</sub> the zonal marginal km (ZMkm) are simply multiplied by the expansion constant and the locational security factor to give the initial transport tariff<sub>i</sub>.

$$NSZMkm_{Gi} \times EC \times LSF = ITT_{Gi}$$

Where  
 $NSZMkm_{Gi}$  = Not-shared Zonal Marginal km for each generation zone  
 EC = Expansion Constant  
 LSF = Locational Security Factor  
 $ITT_{Gi}$  = Initial Transport Tariff (£/MW) for each generation zone

14.15.81 Similarly, for demand the zonal marginal km (ZMkm) are simply multiplied by the expansion constant and the locational security factor to give the initial transport tariff:

$$ZMkm_{Di} \times EC \times LSF = ITT_{Di}$$

Where  
 $ZMkm_{Di}$  = Zonal Marginal km for each demand zone  
 EC = Expansion Constant  
 LSF = Locational Security Factor  
 $ITT_{Di}$  = Initial Transport Tariff (£/MW) for each demand zone

14.15.82 The next step is to multiply these ITTs by the expected metered triad demand and generation capacity to gain an estimate of the initial revenue recovery. Both of these latter parameters are based on forecasts provided by Users and are confidential.

**Initial Revenue Recovery**

$$\sum_{Gi=1}^n (ITT_{Gi} \times G_{Gi}) = ITRR_G \quad \text{and} \quad \sum_{Di=1}^{14} (ITT_{Di} \times D_{Di}) = ITRR_D$$

Where  
 $ITRR_G$  = Initial Transport Revenue Recovery for generation  
 $G_{Gi}$  = Total forecast Generation for each generation zone (based on confidential User forecasts)  
 $ITRR_D$  = Initial Transport Revenue Recovery for demand  
 $D_{Di}$  = Total forecast Metered Triad Demand for each demand zone (based on confidential User forecasts)  
 $n$  = Number of generation zones

**Deriving the Final Local Tariff (£/kW)**

**Local Circuit Tariff**

14.15.83 Generation with a local circuit tariff is calculated by multiplying the Year Round nodal marginal km along the local circuit by the expansion constant and the relevant local security factor (whether onshore or offshore) and summing across local circuits to give the local circuit tariff:

$$\sum_k \frac{NLMkm_{Gj}^L \times EC \times LocalSF_k}{1000} = CLT_{Gi}$$

Where  
 $k$  = Local circuit  $k$  for generator

- Formatted ... [97]
- Formatted ... [98]
- Deleted: ¶
- Formatted ... [99]
- Formatted ... [100]
- Formatted ... [101]
- Formatted ... [102]
- Formatted ... [103]
- Deleted: ¶
- Formatted ... [104]
- Formatted ... [105]
- Formatted ... [106]
- Formatted ... [107]
- Formatted ... [108]
- Formatted ... [109]
- Formatted ... [110]
- Formatted ... [111]
- Formatted ... [112]
- Formatted ... [113]
- Deleted: ¶
- Formatted ... [114]
- Formatted ... [115]
- Formatted ... [116]
- Formatted ... [117]
- Formatted ... [118]
- Deleted: ¶
- Formatted: Bullets and Numbering ... [119]
- Formatted ... [120]
- Deleted: .
- Formatted ... [121]
- Deleted: initial transport tariffs
- Formatted: Bullets and Numbering ... [122]
- Deleted:
- Formatted ... [123]
- Formatted ... [124]
- Deleted: .
- Formatted ... [125]
- Formatted ... [126]
- Formatted ... [127]
- Formatted ... [128]
- Formatted ... [129]
- Formatted ... [130]
- Deleted: -----Page B ... [131]
- Deleted: Where¶ ... [132]
- Formatted ... [133]
- Formatted ... [134]
- Deleted: Initial Trans ... [135]
- Formatted ... [136]
- Formatted ... [137]
- Formatted: Bullets and Numbering ... [138]

- NLMkm<sub>Gj</sub><sup>L</sup> = Year Round Nodal marginal km along local circuit *k* using local circuit expansion factor.
- EC = Expansion Constant
- LocalSF<sub>k</sub> = Local Security Factor for circuit *k*
- CLT<sub>Gi</sub> = Circuit Local Tariff (£/kW)

**Onshore Local Substation Tariff**

**14.15.84** All chargeable generation is subject to the local substation tariff component which is determined by assessing the generation substation type which is the substation at the connection charging boundary, against three cost determining factors: Formatted: Bullets and Numbering

- (a) HV connection voltage – the voltage at the boundary between the User’s connection assets and the transmission system;
- (b) Sum of TEC at the generation substation – the combined TEC of all generation at the connecting substation; and
- (c) The level of redundancy at the generation substation – single busbar / single switch mesh connections are examples of no redundancy connections, whereas examples of connections with redundancy include double busbar and mesh sub station designs.

**14.15.85** Using the above factors, the corresponding £/kW tariffs (quoted to 3dp) that will be applied during 2010/11 are: Formatted: Bullets and Numbering

Substation Rating (b)	Connection Type (c)	Substation Voltage (a)		
		132kV	275kV	400kV
<1320MW	No redundancy	0.133	0.081	0.065
<1320MW	Redundancy	0.301	0.192	0.155
>=1320MW	No redundancy	n/a	0.257	0.208
>=1320MW	Redundancy	n/a	0.417	0.336

**14.15.86** The process for calculating Local Substation Tariffs will be carried out for the first year of the price control and will subsequently be indexed by RPI for each subsequent year of the price control period. Formatted: Bullets and Numbering

**14.15.87** The effective **Local Tariff** (£/kW) is calculated as the sum of the circuit and substation onshore and/or offshore components: Formatted: Bullets and Numbering

$$ELT_{Gi} = CLT_{Gi} + SLT_{Gi}$$

- Where
- ELT<sub>Gi</sub> = Effective Local Tariff (£/kW)
- SLT<sub>Gi</sub> = Substation Local Tariff (£/kW)

**14.15.88** Where tariffs do not change mid way through a charging year, final local tariffs will be the same as the effective tariffs: Formatted: Bullets and Numbering

- ELT<sub>Gi</sub> = LT<sub>Gi</sub>
- Where
- LT<sub>Gi</sub> = Final Local Tariff (£/kW)

**14.15.89** Where tariffs are changed part way through the year, the final tariffs will be calculated by scaling the effective tariffs to reflect that the tariffs are only applicable for part of the year and parties may have already incurred TNUoS liability. Formatted: Bullets and Numbering

$$FT_{Gi} = \frac{12 \times \left( ET_{Gi} \times \sum_{Gi=1}^n G_{Gi} - FL_{Gi} \right)}{b \times \sum_{Gi=1}^n G_{Gi}} \quad \text{and} \quad FT_{Di} = \frac{12 \times \left( ET_{Di} \times \sum_{Di=1}^{14} D_{Di} - FL_{Di} \right)}{b \times \sum_{Di=1}^{14} D_{Di}}$$

Where:

b = number of months the revised tariff is applicable for

FLL = Forecast local liability incurred over the period that the original tariff is applicable for

**14.15.90** For the purposes of charge setting, the total local charge revenue is calculated by:

Formatted: Bullets and Numbering

$$LCRR_G = \sum_{j=Gi} LT_{Gi} * G_j$$

Where

LCRR<sub>G</sub> = Local Charge Revenue Recovery

G<sub>j</sub> = Forecast chargeable Generation or Transmission Entry Capacity in kW (as applicable) for each generator (based on confidential information received from Users)

### Offshore substation local tariff

**14.15.91** All offshore chargeable generation is subject to an offshore substation tariff. The offshore substation tariff shall be the sum of transformer, switchgear and platform components.

Formatted: Bullets and Numbering

**14.15.92** Each tariff component, expressed in £/kW, shall be the ratio of the Offshore Transmission Owner revenue (£) and rating associated with the transformers, switchgear or platform (kW) at each offshore substation. The Offshore Transmission Owner revenue of each tariff component shall include that associated with asset spares. In the case of the platform component, the relevant rating shall be the lower of the transformer or switchgear ratings. As with the offshore circuit expansion factors, the Offshore Transmission Owner revenue associated with each tariff component shall be averaged over the remaining years of the NETSO price control.

Formatted: Bullets and Numbering

**14.15.93** Offshore Transmission Owner revenue associated with interest during construction and project development overheads will be attributed to the relevant asset category with which it is associated. If these or any other costs included in the Offshore Transmission Owner revenue are not readily attributable to a given asset category, they will be pro-rated across the various asset categories based on their relative cost.

Formatted: Bullets and Numbering

**14.15.94** For 2010/11 a discount of £0.345590/kW shall be provided to the offshore substation tariff to reflect the average cost of civil engineering for onshore substations. This will be inflated by RPI each year and reviewed every price control period.

Formatted: Bullets and Numbering

**14.15.95** Offshore substation tariffs shall be inflated by RPI each year and reviewed every price control period.

Formatted: Bullets and Numbering

**14.15.96** The revenue from the offshore substation local tariff is calculated by:

Formatted: Bullets and Numbering

$$SLTR = \sum_{\substack{\text{All offshore} \\ \text{substations}}} \left( SLT_k \times \sum_k Gen_k \right)$$

Formatted: Indent: Left: 3.81 cm

Where:

SLT<sub>k</sub> = the offshore substation tariff for substation k

Gen<sub>k</sub> = the generation connected to offshore substation k

**The Residual Tariff**

**14.15.97** The total revenue to be recovered through TNUoS charges is determined each year with reference to the Transmission Licensees’ Price Control formulas less the costs expected to be recovered through Pre-Vesting connection charges. Hence in any given year t, a target revenue figure for TNUoS charges (TRR<sub>t</sub>) is set after adjusting for any under or over recovery for and including, the small generators discount is as follows:

**Formatted:** Bullets and Numbering

$$TRR_t = R_t - PVC_t - SG_{t-1}$$

Where

- TRR<sub>t</sub> = TNUoS Revenue Recovery target for year t
- R<sub>t</sub> = Forecast Revenue allowed under The Company’s RPI-X Price Control Formula for year t (this term includes a number of adjustments, including for over/under recovery from the previous year). For further information, refer to Special Condition D2 of The Company’s Transmission Licence.
- PVC<sub>t</sub> = Forecast Revenue from Pre-Vesting connection charges for year t
- SG<sub>t-1</sub> = The proportion of the under/over recovery included within R<sub>t</sub> which relates to the operation of statement C13 of the The Company Transmission Licence. Should the operation of statement C13 result in an under recovery in year t – 1, the SG figure will be positive and vice versa for an over recovery.

**14.15.98** In normal circumstances, the revenue forecast to be recovered from the corrected transport tariffs will not equate to the total revenue target. This is due to a number of factors. For example, the transport model assumes, for simplicity, smooth incremental transmission investments can be made. In reality, transmission investment can only be made in discrete 'lumps'. The transmission system has been planned and developed over a long period of time. Forecasts and assessments used for planning purposes will not have been borne out precisely by events and therefore some distinction between an optimal system for one year and the actual system can be expected.

**Formatted:** Bullets and Numbering

**14.15.99** As a result of the factors above, in order to ensure adequate revenue recovery, a constant non-locational **Residual Tariff** for generation and demand is calculated, which includes infrastructure substation asset costs. It is added to the corrected transport tariffs so that the correct generation / demand revenue split is maintained and the total revenue recovery is achieved.

**Formatted:** Bullets and Numbering

$$RT_D = \frac{(p \times TRR) - ITRR_D}{\sum_{Di=1}^{14} D_{Di}}$$

$$RT_G = \frac{[(1 - p) \times TRR] - ITRR_G - LCRR_G}{\sum_{Gi=1}^n G_{Gi}}$$

**Deleted:**  $RT_D = \frac{(p \times TRR)}{\sum_{Di=1}^{14} D_{Di}}$

**Deleted:**  $RT_G = [(1 - p) \times \dots]$

- Where
- RT = Residual Tariff (£/MW)
- p = Proportion of revenue to be recovered from demand

**Final £/kW Tariff**

**14.15.100** The effective Transmission Network Use of System tariff (TNUoS) can now be calculated as the sum of the corrected transport wider tariff, the non-locational residual tariff and the local tariff:

**Formatted:** Bullets and Numbering

$$ET_{Gi} = \frac{ITT_{Gi} + RT_G}{1000} + LT_{Gi} \quad \text{and} \quad ET_{Di} = \frac{ITT_{Di} + RT_D}{1000}$$

Where:

ET = Effective TNUoS Tariff expressed in £/kW

**Deleted:**  $ET_{Gi} = \frac{ITT_{Gi}^{PS}}{1000} + LT_{Gi}$   
and

**Deleted:**  
 $ET_{Di} = \frac{ITT_{Di}^{PS} + ITT_{Di}^{YR}}{1000}$

**14.15.101** Where tariffs do not change mid way through a charging year, final demand and generation tariffs will be the same as the effective tariffs.

$$FT_{Gi} = ET_{Gi} \quad \text{and} \quad FT_{Di} = ET_{Di}$$

**Formatted:** Font: Arial, 11 pt

**Formatted:** Font: Arial

**Deleted:** ¶

**14.15.102** Where tariffs are changed part way through the year, the final tariffs will be calculated by scaling the effective tariffs to reflect that the tariffs are only applicable for part of the year and parties may have already incurred TNUoS liability.

**Formatted:** Bullets and Numbering

**Formatted:** Bullets and Numbering

$$FT_{Gi} = \frac{12 \times \left( ET_{Gi} \times \sum_{Gi=1}^n G_{Gi} - FL_{Gi} \right)}{b \times \sum_{Gi=1}^n G_{Gi}} \quad \text{and} \quad FT_{Di} = \frac{12 \times \left( ET_{Di} \times \sum_{Di=1}^{14} D_{Di} - FL_{Di} \right)}{b \times \sum_{Di=1}^{14} D_{Di}}$$

**Deleted:**  $FT_{Gi} = \frac{12 \times \left( ET_{Gi} \times \sum_{Gi=1}^n G_{Gi} - FL_{Gi} \right)}{b \times \sum_{Gi=1}^n G_{Gi}}$

Where:

b = number of months the revised tariff is applicable for

FL = Forecast liability incurred over the period that the original tariff is applicable for

**Deleted:**

**14.15.103** If the final demand TNUoS Tariff results in a negative number then this is collared to £0/kW with the resultant non-recovered revenue smeared over the remaining demand zones:

**Formatted:** Bullets and Numbering

If  $FT_{Di} < 0$ , then  $i = 1$  to  $z$

Therefore,

$$NRRT_D = \frac{\sum_{i=1}^z (FT_{Di} \times D_{Di})}{\sum_{i=z+1}^{14} D_{Di}}$$

Therefore the revised Final Tariff for the demand zones with positive Final tariffs is given by:

For  $i = 1$  to  $z$ :  $RFT_{Di} = 0$

**Field Code Changed**

For  $i = z+1$  to  $14$ :  $RFT_{Di} = FT_{Di} + NRRT_D$

**Field Code Changed**

Where

$NRRT_D$  = Non Recovered Revenue Tariff (£/kW)

$RFT_{Di}$  = Revised Final Tariff (£/kW)



**14.15.104** The tariffs applicable for any particular year are detailed in The Company's **Statement of Use of System Charges**, which is available from the **Charging website**. Archived tariff information may also be obtained from the Charging website.

**Formatted:** Bullets and Numbering

**14.15.105** The zonal maps referenced in The Company's **Statement of Use of System Charges** and available on the **Charging website** contain detailed information for the charging year in question of which Grid Supply Points fall into which TNUoS zones.

**Formatted:** Bullets and Numbering

**14.15.106** New Grid Supply Points will be classified into zones on the following basis:

**Formatted:** Bullets and Numbering

- For demand zones, according to the GSP Group to which the Grid Supply Point is allocated for energy market settlement purposes.
- For generation zones, with reference to the geographic proximity to existing zones and, where close to a boundary between existing zones, with reference to the marginal costs arising from transport model studies. The GSP will then be allocated to the zone, which contains the most similar marginal costs.

**Formatted:** Indent: Left: 1.25 cm, Hanging: 0.75 cm, Bulleted + Level: 1 + Aligned at: 0 cm + Tab after: 0.63 cm + Indent at: 0.63 cm, Tabs: 2 cm, List tab + Not at 0.63 cm + 1.27 cm

**Formatted:** Indent: Left: 1.25 cm, Hanging: 0.75 cm, Bulleted + Level: 1 + Aligned at: 0 cm + Tab after: 0.63 cm + Indent at: 0.63 cm, Tabs: 2 cm, List tab + Not at 0.63 cm + 1.27 cm

**Formatted:** Bullets and Numbering

**14.15.107** The Company has available, upon request, the DCLF ICRP transport model, tariff model template and data necessary to run the model, consisting of nodal values of generation and demand connection points to the NETS. The model and data will enable the basic nodal charges to be determined and will also allow sensitivity analysis concerning alternative developments of generation and demand to be undertaken. The model is available from the Charging Team and whilst it is free of charge, it is provided under licence to restrict its distribution and commercial use.

**Formatted:** Bullets and Numbering

**14.15.108** The Company will be pleased to run specific sensitivity studies for Users under a separate study contract in line with the fees set out in the **Statement of Use of System Charges**. Please contact the **Charging Team**.

**14.15.109** The factors which will affect the level of TNUoS charges from year to year include:

**Formatted:** Bullets and Numbering

- the forecast level of peak demand on the system
- the Price Control formula (including the effect of any under/over recovery from the previous year)
- the expansion constant
- the locational security factor
- the ZSF
- changes in the transmission network
- HVDC circuit impedance calculation
- changes in the pattern of generation capacity and demand

**Deleted:**

**Deleted:** ,

**Deleted:** ),

**Deleted:** ,

**Deleted:** ,

**Deleted:** and

**Deleted:** .

**14.15.110** In accordance with Standard Licence Condition C13, generation directly connected to the NETS 132kV transmission network which would normally be subject to generation TNUoS charges but would not, on the basis of generating capacity, be liable for charges if it were connected to a licensed distribution network qualifies for a reduction in transmission charges by a designated sum, determined by the Authority. Any shortfall in recovery will result in a unit amount increase in demand charges to compensate for the deficit. Further information is provided in the Statement of the Use of System Charges.

**Formatted:** Bulleted + Level: 1 + Aligned at: 3.81 cm + Tab after: 4.51 cm + Indent at: 4.51 cm, Tabs: Not at 1.27 cm

**Formatted:** Bullets and Numbering

**Stability & Predictability of TNUoS tariffs**

**14.15.111** A number of provisions are included within the methodology to promote the stability and predictability of TNUoS tariffs. These are described in 14.29.

**Formatted:** Bullets and Numbering

**Deleted:** 8

## 14.16 Derivation of the Transmission Network Use of System Energy Consumption Tariff and Short Term Capacity Tariffs

Deleted: .....

14.16.1 For the purposes of this section, Lead Parties of Balancing Mechanism (BM) Units that are liable for Transmission Network Use of System Demand Charges are termed Suppliers.

14.16.2 Following calculation of the Transmission Network Use of System £/kW Demand Tariff (as outlined in Chapter 2: Derivation of the TNUoS Tariff) for each GSP Group is calculated as follows:

$$p/kWh \text{ Tariff} = \frac{(NHHD_F * \text{£/kW Tariff} - FL_G)}{NHHC_G} * 100$$

Where:

**£/kW Tariff** = The £/kW Effective Demand Tariff (£/kW), as calculated previously, for the GSP Group concerned.

**NHHD<sub>F</sub>** = The Company's forecast of Suppliers' non-half-hourly metered Triad Demand (kW) for the GSP Group concerned. The forecast is based on historical data.

**FL<sub>G</sub>** = Forecast Liability incurred for the GSP Group concerned.

**NHHC<sub>G</sub>** = The Company's forecast of GSP Group non-half-hourly metered total energy consumption (kWh) for the period 16:00 hrs to 19:00hrs inclusive (i.e. settlement periods 33 to 38) inclusive over the period the tariff is applicable for the GSP Group concerned.

### Short Term Transmission Entry Capacity (STTEC) Tariff

14.16.3 The Short Term Transmission Entry Capacity (STTEC) tariff for positive zones is derived from the Effective Tariff (ET<sub>Gi</sub>) annual TNUoS £/kW tariffs (14.15.109). If multiple set of tariffs are applicable within a single charging year, the Final Tariff used in the STTEC calculation will be prorated in an identical manner to that used when calculating a generators annual liability. The periods over which the tariff would be prorated would be identical to the periods used when calculating the wider tariff (i.e. over the whole financial year, not just the period that the STTEC is applicable for). STTECs will not be reconciled following a mid year charge change. The premium associated with the flexible product is associated with the analysis that 90% of the annual charge is linked to the system peak. The system peak is likely to occur in the period of November to February inclusive (120 days, irrespective of leap years). The calculation for positive generation zones is as follows:

Deleted: relevant

$$\frac{FT_{Gi} \times 0.9 \times \text{STTEC Period}}{120} = \text{STTEC tariff (£/kW/period)}$$

Where:

FT = Final annual TNUoS Tariff expressed in £/kW  
 Gi = Generation zone  
 STTEC Period = A period applied for in days as defined in the CUSC

14.16.4 For the avoidance of doubt, the charge calculated under 14.16.3 above will represent each single period application for STTEC. Requests for multiple STTEC periods will result in each STTEC period being calculated and invoiced separately.

14.16.5 The STTEC tariff for generators with negative final tariffs is set to zero to prevent Users receiving greater than 100% of the annual TNUoS payment that would have been received for that capacity under a firm TEC.

### Limited Duration Transmission Entry Capacity (LDTEC) Tariffs

14.16.6 The Limited Duration Transmission Entry Capacity (LDTEC) tariff for positive zones is derived from the equivalent zonal STTEC tariff for up to the initial 17 weeks of LDTEC in a given charging year (whether consecutive or not). For the remaining weeks of the year, the LDTEC tariff is set to collect the balance of the annual TNUoS liability over the maximum duration of LDTEC that can be granted in a single application. If multiple set of tariffs are applicable within a single charging year, the Final Tariff used in the LDTEC calculation will be prorated in an identical manner to that used when calculating a generators annual liability. The periods over which the tariff would be prorated would be identical to the periods used when calculating the wider tariff (ie over the whole financial year, not just the period that the STTEC is applicable for). LDTECs will not be reconciled following a mid year charge change:

Initial 17 weeks (high rate):

$$\text{LDTEC tariff (£/kW/week)} = \frac{FT_{G_i} \times 0.9 \times 7}{120}$$

Remaining weeks (low rate):

$$\text{LDTEC tariff (£/kW/week)} = \frac{FT_{G_i} \times 0.1075 \times 7}{316 - 120} \times (1 + P)$$

where  $FT$  is the final annual TNUoS tariff expressed in £/kW;  
 $G_i$  is the generation TNUoS zone; and  
 $P$  is the premium in % above the annual equivalent TNUoS charge as determined by The Company, which shall have the value 0.

14.16.7 The LDTEC tariff for generators with negative final tariffs is set to zero to prevent Users receiving greater than 100% of the annual TNUoS payment that would have been received for that capacity under a firm TEC.

14.16.8 The tariffs applicable for any particular year are detailed in The Company's **Statement of Use of System Charges** which is available from the **Charging website**. Historical tariffs are also available on the **Charging website**.

## 14.17 Demand Charges

### Parties Liable for Demand Charges

14.17.1 The following parties shall be liable for demand charges:

- The Lead Party of a Supplier BM Unit;
- Power Stations with a Bilateral Connection Agreement;
- Parties with a Bilateral Embedded Generation Agreement

**Formatted:** Indent: Left: 2.54 cm, Bulleted + Level: 1 + Aligned at: 0 cm + Tab after: 0.63 cm + Indent at: 0.63 cm, Tabs: 2.54 cm, List tab + Not at 0.63 cm + 1.27 cm

14.17.2 14.25 Classification of parties for charging purposes provides an illustration of how a party is classified in the context of Use of System charging and refers to the paragraphs most pertinent to each party.

**Formatted:** Indent: Left: 2.54 cm, Bulleted + Level: 1 + Aligned at: 0 cm + Tab after: 0.63 cm + Indent at: 0.63 cm, Tabs: 2.54 cm, List tab + Not at 0.63 cm + 1.27 cm

### Basis of Demand Charges

14.17.3 Demand charges are based on a de-minimus £0/kW charge for Half Hourly and £0/kWh for Non Half Hourly metered demand.

**Formatted:** Indent: Left: 2.54 cm, Bulleted + Level: 1 + Aligned at: 0 cm + Tab after: 0.63 cm + Indent at: 0.63 cm, Tabs: 2.54 cm, List tab + Not at 0.63 cm + 1.27 cm

14.17.4 Chargeable Demand Capacity is the value of Triad demand (kW). Chargeable Energy Capacity is the energy consumption (kWh). The definition of both these terms is set out below.

14.17.5 If there is a single set of demand tariffs within a charging year, the Chargeable Demand Capacity is multiplied by the relevant demand tariff, for the calculation of demand charges.

14.17.6 If there is a single set of energy tariffs within a charging year, the Chargeable Energy Capacity is multiplied by the relevant energy consumption tariff for the calculation of energy charges..

14.17.7 If multiple sets of demand tariffs are applicable within a single charging year, demand charges will be calculated by multiplying the Chargeable Demand Capacity by the relevant tariffs pro rated across the months that they are applicable for, as below,

$$Annual\ Liability_{Demand} = Chargeable\ Demand\ Capacity \times \left( \frac{(a \times Tariff\ 1) + (b \times Tariff\ 2)}{12} \right)$$

where:

Tariff 1 = Original tariff,

Tariff 2 = Revised tariff,

a = Number of months over which the original tariff is applicable,

b = Number of months over which the revised tariff is applicable.

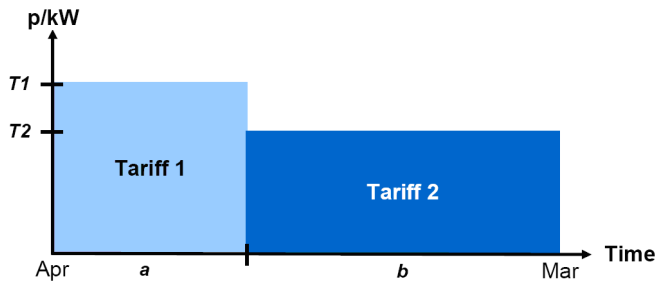

14.17.8 If multiple sets of energy tariffs are applicable within a single charging year, energy charges will be calculated by multiplying relevant Tariffs by the Chargeable Energy Capacity over the period that that the tariffs are applicable for and summing over the year.

$$Annual Liability_{Energy} = Tariff\ 1 \times \sum_{T1_s}^{T1_E} Chargeable\ Energy\ Capacity + Tariff\ 2 \times \sum_{T2_s}^{T2_E} Chargeable\ Energy\ Capacity$$

Where:

- T1<sub>s</sub> = Start date for the period for which the original tariff is applicable,
- T1<sub>E</sub> = End date for the period for which the original tariff is applicable,
- T2<sub>s</sub> = Start date for the period for which the revised tariff is applicable,
- T2<sub>E</sub> = End date for the period for which the revised tariff is applicable.

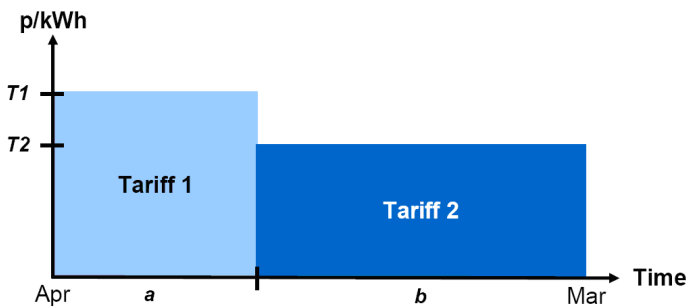

### Supplier BM Unit

14.17.9 A Supplier BM Unit charges will be the sum of its energy and demand liabilities where::

- The Chargeable Demand Capacity will be the average of the Supplier BM Unit's half-hourly metered demand during the Triad (and the £/kW tariff), and
- The Chargeable Energy Capacity will be the Supplier BM Unit's non half-hourly metered energy consumption over the period 16:00 hrs to 19:00 hrs inclusive every day over the Financial Year (and the p/kWh tariff).

**Formatted:** Indent: Left: 2.5 cm, Bulleted + Level: 1 + Aligned at: 0 cm + Tab after: 0.63 cm + Indent at: 0.63 cm, Tabs: 3.14 cm, List tab + Not at 0.63 cm + 1.27 cm

**Formatted:** Indent: Left: 2.48 cm, Bulleted + Level: 1 + Aligned at: 0 cm + Tab after: 0.63 cm + Indent at: 0.63 cm, Tabs: 3.12 cm, List tab + Not at 0.63 cm + 1.27 cm

**Power Stations with a Bilateral Connection Agreement and Licensable Generation with a Bilateral Embedded Generation Agreement**

14.17.10 The Chargeable Demand Capacity for a Power Station with a Bilateral Connection Agreement or Licensable Generation with a Bilateral Embedded Generation Agreement will be based on the average of the net import over each Triad leg of the BM Units associated with the Power Station (in Appendix C of its Bilateral Connection Agreement or Bilateral Embedded Generation Agreement, including metered additional load) during the Triad.

**Exemptible Generation and Derogated Distribution Interconnectors with a Bilateral Embedded Generation Agreement**

14.17.11 The Chargeable Demand Capacity for Exemptible Generation and Derogated Distribution Interconnectors with a Bilateral Embedded Generation Agreement will be based on the average of the metered volume of each BM Unit specified in Appendix C of the Bilateral Embedded Generation Agreement during the Triad.

**Small Generators Tariffs**

14.17.12 In accordance with Standard Licence Condition C13, any under recovery from the MAR arising from the small generators discount will result in a unit amount of increase to all GB demand tariffs.

**The Triad**

14.17.13 The Triad is used as a short hand way to describe the three settlement periods of highest transmission system demand within a Financial Year, namely the half hour settlement period of system peak demand and the two half hour settlement periods of next highest demand, which are separated from the system peak demand and from each other by at least 10 Clear Days, between November and February of the Financial Year inclusive. Exports on directly connected Interconnectors and Interconnectors capable of exporting more than 100MW to the Total System shall be excluded when determining the system peak demand. An illustration is shown below.

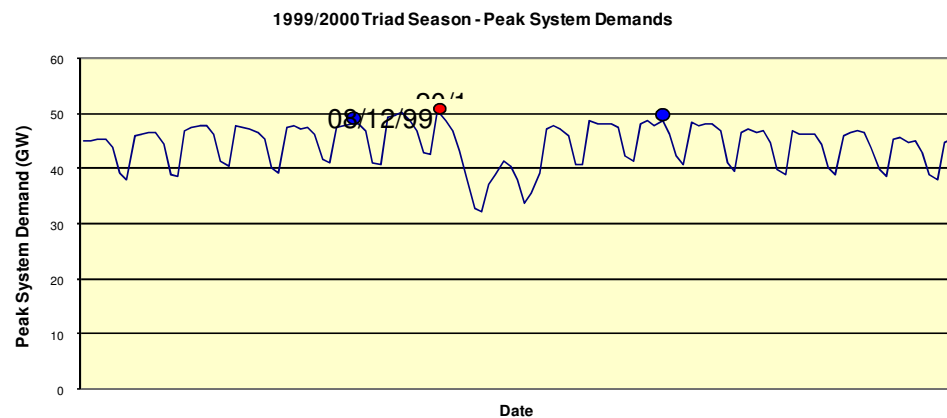

**Half-hourly metered demand charges**

14.17.14 For Supplier BMUs and BM Units associated with Exemptible Generation and Derogated Distribution Interconnectors with a Bilateral Embedded Generation

Agreement, if the average half-hourly metered volume over the Triad results in an import, the Chargeable Demand Capacity will be positive resulting in the BMU being charged. If the average half-hourly metered volume over the Triad results in an export, the Chargeable Demand Capacity will be negative resulting in the BMU being paid. For the avoidance of doubt, parties with Bilateral Embedded Generation Agreements that are liable for Generation charges will not be eligible for a negative demand credit.

**Netting off within a BM Unit**

14.17.15 The output of generators and Distribution Interconnectors registered as part of a Supplier BM Unit will have already been accounted for in the Supplier BM Unit demand figures upon which The Company Transmission Network Use of System Demand charges are based.

**Monthly Charges**

14.17.16 Throughout the year Users' monthly demand charges will be based on their forecasts of:

- half-hourly metered demand to be supplied during the Triad for each BM Unit, multiplied by the relevant zonal £/kW tariff; and
- non-half hourly metered energy to be supplied over the period 16:00 hrs to 19:00 hrs inclusive every day over the Financial Year for each BM Unit, multiplied by the relevant zonal p/kWh tariff

Users' annual TNUoS demand charges are based on these forecasts and are split evenly over the 12 months of the year. Users have the opportunity to vary their demand forecasts on a quarterly basis over the course of the year, with the demand forecast requested in February relating to the next Financial Year. Users will be notified of the timescales and process for each of the quarterly updates. The Company will revise the monthly Transmission Network Use of System demand charges by calculating the annual charge based on the new forecast, subtracting the amount paid to date, and splitting the remainder evenly over the remaining months. For the avoidance of doubt, only positive demand forecasts (i.e. representing an import from the system) will be accepted.

**Formatted:** Indent: Left: 2.54 cm, Hanging: 0.75 cm, Bulleted + Level: 1 + Aligned at: 0 cm + Tab after: 0.63 cm + Indent at: 0.63 cm, Tabs: 3.29 cm, List tab + Not at 0.63 cm + 1.27 cm

**Formatted:** Indent: Left: 2.54 cm, Hanging: 0.75 cm, Bulleted + Level: 1 + Aligned at: 0 cm + Tab after: 0.63 cm + Indent at: 0.63 cm, Tabs: 3.29 cm, List tab + Not at 0.63 cm + 1.27 cm

14.17.17 Users should submit reasonable demand forecasts in accordance with the CUSC. The Company shall use the following methodology to derive a forecast to be used in determining whether a User's forecast is reasonable, in accordance with the CUSC, and this will be used as a replacement forecast if the User's total forecast is deemed unreasonable. The Company will, at all times, use the latest available Settlement data.

For existing Users:

i) The User's Triad demand for the preceding Financial Year will be used where User settlement data is available and where The Company calculates its forecast before the Financial Year. Otherwise, the User's average weekday settlement period 35 half-hourly metered (HH) demand in the Financial Year to date is compared to the equivalent average demand for the corresponding days in the preceding year. The percentage difference is then applied to the User's HH demand at Triad in the preceding Financial Year to derive a forecast of the User's HH demand at Triad for this Financial Year.

**Formatted:** Indent: Left: 2.87 cm, Numbered + Level: 1 + Numbering Style: i, ii, iii, ... + Start at: 1 + Alignment: Left + Aligned at: 0 cm + Tab after: 1 cm + Indent at: 1 cm, Tabs: 2.62 cm, List tab + Not at 1 cm + 1.27 cm

ii) The User's non half-hourly metered (NHH) energy consumption over the period 16:00 hrs to 19:00 hrs every day in the Financial Year to date is compared to the equivalent energy consumption over the corresponding days in the preceding year. The percentage difference is then applied to the User's total NHH energy

**Formatted:** Indent: Left: 2.87 cm, Numbered + Level: 1 + Numbering Style: i, ii, iii, ... + Start at: 2 + Alignment: Tab after: 1 cm + Indent at: 1 cm, Tabs: 2.62 cm, List tab + Not at 1 cm + 1.27 cm

consumption in the preceding Financial Year to derive a forecast of the User's NHH energy consumption for this Financial Year.

For new Users who have completed a Use of System Supply Confirmation Notice in the current Financial Year:

iii) The User's average weekday settlement period 35 half-hourly metered (HH)\* demand over the last complete month for which The Company has settlement data is calculated. Total system average HH demand for weekday settlement period 35 for the corresponding month in the previous year is compared to total system HH demand at Triad in that year and a percentage difference is calculated. This percentage is then applied to the User's average HH demand for weekday settlement period 35 over the last month to derive a forecast of the User's HH demand at Triad for this Financial Year.

**Formatted:** Indent: Left: 2.87 cm, Numbered + Level: 1 + Numbering Style: i, ii, iii, ... + Start at: 3 + Alignment: Left + Aligned at: 0 cm + Tab after: 1 cm + Indent at: 1 cm, Tabs: 2.62 cm, List tab + Not at 1 cm + 1.27 cm

iv) The User's non half-hourly metered (NHH) energy consumption over the period 16:00 hrs to 19:00 hrs every day over the last complete month for which The Company has settlement data is noted. Total system NHH energy consumption over the corresponding month in the previous year is compared to total system NHH energy consumption over the remaining months of that Financial Year and a percentage difference is calculated. This percentage is then applied to the User's NHH energy consumption over the month described above, and all NHH energy consumption in previous months is added, in order to derive a forecast of the User's NHH metered energy consumption for this Financial Year.

**Formatted:** Indent: Left: 2.87 cm, Numbered + Level: 1 + Numbering Style: i, ii, iii, ... + Start at: 3 + Alignment: Left + Aligned at: 0 cm + Tab after: 1 cm + Indent at: 1 cm, Tabs: 2.62 cm, List tab + Not at 1 cm + 1.27 cm

14.17.18 14.27 Determination of The Company's Forecast for Demand Charge Purposes illustrates how the demand forecast will be calculated by The Company.

## Reconciliation of Demand Charges

14.17.19 The reconciliation process is set out in the CUSC. The demand reconciliation process compares the monthly charges paid by Users against actual outturn charges. Due to the Settlements process, reconciliation of demand charges is carried out in two stages; initial reconciliation and final reconciliation.

### Initial Reconciliation of demand charges

14.17.20 The initial reconciliation process compares Users' demand forecasts and corresponding monthly charges paid over the year against actual outturn data (using latest Settlement data available at the time) and corresponding charges. Initial reconciliation is carried out in two parts; Initial Reconciliation Part 1 deals with the reconciliation of half-hourly metered demand charges and Initial Reconciliation Part 2 deals with the reconciliation of non-half-hourly metered demand charges.

### Initial Reconciliation Part 1– Half-hourly metered demand

14.17.21 The Company will identify the periods forming the Triad once it has received Central Volume Allocation data from the Settlement Administration Agent for all days up to and including the last day of February. Once The Company has notified Users of the periods forming the Triad they will not be changed even if disputes are subsequently resolved which would change the periods forming the Triad.

14.17.22 Initial outturn charges for half-hourly metered demand will be determined using the latest available data of actual average Triad demand (kW) multiplied by the zonal demand tariff(s) (£/kW) applicable to the months concerned for each zone for that Financial Year. These actual values are then reconciled against the monthly charges paid in respect of half-hourly demand.



### **Initial Reconciliation Part 2 – Non-half-hourly metered demand**

14.17.23 Actual payments for non-half-hourly metered demand will be determined using the latest available actual energy consumption data (kWh) for the period 16:00 hrs to 19:00 hrs inclusive (i.e. settlement periods 33 to 38) over the year multiplied by the energy consumption tariff(s) (p/kWh) applicable to the months concerned for each zone. These actual values are then reconciled against the monthly charges paid in respect of non-half-hourly energy consumption.

### **Final Reconciliation of demand charges**

14.17.24 The final reconciliation process compares Users' charges (as calculated during the initial reconciliation process using the latest available data) against final outturn demand charges (based on final settlement data).

14.17.25 Final actual charges will be determined using the final demand reconciliation data taken from the Final Reconciliation Settlement Run or the Final Reconciliation Volume Allocation Run.

### **Reconciliation of manifest errors**

14.17.26 In the event that a manifest error, or multiple errors in the calculation of TNUoS tariffs results in a material discrepancy in a Users TNUoS tariff, the reconciliation process for all Users qualifying under Section 14.17.28 will be in accordance with Sections 14.17.20 to 14.17.25. The reconciliation process shall be carried out using recalculated TNUoS tariffs. Where such reconciliation is not practicable, a post-year reconciliation will be undertaken in the form of a one-off payment.

14.17.27 A manifest error shall be defined as any of the following:

- a) an error in the transfer of relevant data between the Transmission Licensees or Distribution Network Operators;
- b) an error in the population of the Transport Model with relevant data;
- c) an error in the function of the Transport Model; or
- d) an error in the inputs or function of the Tariff Model.

14.17.28 A manifest error shall be considered material in the event that such an error or, the net effect of multiple errors, has an impact of the lesser of either:

- a) an error in a User's TNUoS tariff of at least +/-£0.50/kWh; or
- b) an error in a User's TNUoS tariff which results in an error in the annual TNUoS charge of a User in excess of +/-£250,000.

14.17.29 A manifest error shall only be reconciled if it has been identified within the charging year for which the error has an effect. Errors identified outside of this period will not be eligible for reconciliation retrospectively.

### **Further Information**

14.17.30 14.24 Reconciliation of Demand Related Transmission Network Use of System Charges of this statement illustrates how the monthly charges are reconciled against the actual values for demand and consumption for half-hourly and non-half-hourly metered demand respectively.

14.17.31 **The Statement of Use of System Charges** contains the £/kW zonal demand tariffs, and the p/kWh energy consumption tariffs for the current Financial Year.

14.17.32 14.26 Transmission Network Use of System Charging Flowcharts of this statement contains flowcharts demonstrating the calculation of these charges for those parties liable.

## 14.18 Generation charges

### Parties Liable for Generation Charges

14.18.1 The following CUSC parties shall be liable for generation charges:

- i) Parties of Generators that have a Bilateral Connection Agreement with The Company.
- ii) Parties of Licensable Generation that have a Bilateral Embedded Generation Agreement with The Company.

14.18.2 14.25 Classification of parties for charging purposes provides an illustration of how a party is classified in the context of Use of System charging and refers to the relevant paragraphs most pertinent to each party.

### Structure of Generation Charges

14.18.3 Generation Tariffs are comprised of Wider and Local Tariffs. The Wider Tariff is comprised of (i) a Wider element which factors in the sharing of wider costs between different generation types and (ii) a residual element.

14.18.4 The Local Tariff contains a substation element and may also contain a circuit element. Specifically, all transmission connected generation will be liable to pay a local substation charge, with some of these also being liable to pay a local circuit charge. For the avoidance of doubt, embedded generation has a zero local tariff.

14.18.5 The intention of the charging rules is to charge the same physical entity only once.

14.18.6 The basis of the generation charge for Power Stations is the Chargeable Capacity and the short-term chargeable capacity (as defined below for positive and negative charging zones).

14.18.7 If there is a single set of Wider and Local generation tariffs within a charging year, the Chargeable Capacity is multiplied by the relevant generation tariff to calculate the annual liability of a generator.

$$\underline{Local\ Annual\ Liability = Chargeable\ Capacity \times Local\ Tariff}$$

The Wider Tariff is broken down into two components as described in 14.18.3. given below:

$$\underline{Wider\ Annual\ Liability = Chargeable\ Capacity \times (Wider\ Tariff + Residual\ Tariff)}$$

14.18.8 If multiple sets of Wider and Local generation tariffs are applicable within a single charging year, the Chargeable Capacity is multiplied by the relevant tariffs pro rated over the entire charging year, across the months that they are applicable for.

$$Annual\ Liability = \left( \frac{a \times Liability\ 1 + b \times Liability\ 2}{12} \right)$$

where:

Liability 1 = Original annual liability,

Liability 2 = Revised annual liability,

**Formatted:** Indent: Left: 2.87 cm, Hanging: 1.27 cm, Numbered + Level: 1 + Numbering Style: i, ii, iii, ... + Start at: 1 + Alignment: Left + Aligned at: 0 cm + Tab after: 1.27 cm + Indent at: 0.63 cm, Tabs: 4.14 cm, List tab + Not at 1.27 cm

**Formatted:** Indent: Left: 2.87 cm, Hanging: 1.27 cm, Numbered + Level: 1 + Numbering Style: i, ii, iii, ... + Start at: 1 + Alignment: Left + Aligned at: 0 cm + Tab after: 1.27 cm + Indent at: 0.63 cm, Tabs: 4.14 cm, List tab + Not at 1.27 cm

**Deleted:** Charges

**Deleted:** Charges,

**Deleted:** the latter of which

**Formatted:** Indent: Left: 1.27 cm

**Formatted:** Indent: Left: 2.87 cm

**Deleted:** Tariff

**Deleted:** tariff

**Deleted:** Tariff

**Deleted:** tariff

a = Number of months over which the original liability is applicable,  
 b = Number of months over which the revised liability is applicable.

**Deleted:** tariff

**Deleted:** tariff

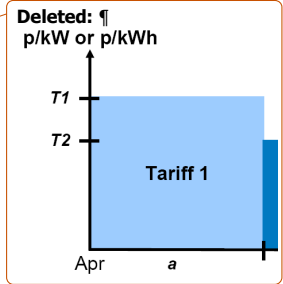
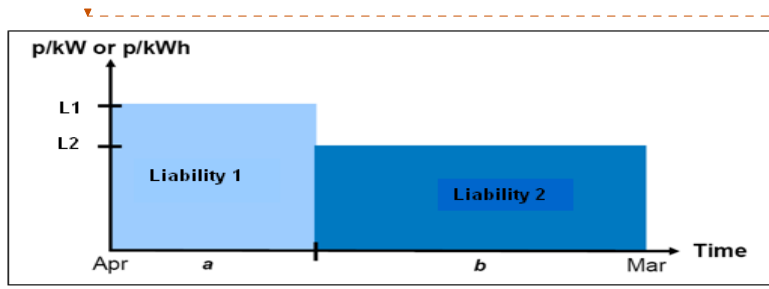

14.18.9 For the avoidance of doubt if there are multiple sets of Wider and Local generation tariffs applicable within a single charging year and a tariff changes from being positive to negative or vice versa, the Chargeable Capacity for the entire charging year will be determined based on the net position of the pro rated tariffs for each affected generator.

### Basis of Wider Generation Charges

#### Generation with positive wider tariffs

14.18.10 The Chargeable Capacity for Power Stations with positive wider generation tariffs is the highest Transmission Entry Capacity (TEC) applicable to that Power Station for that Financial Year. A Power Station should not exceed its TEC as to do so would be in breach of the CUSC, except where it is entitled to do so under the specific circumstances laid out in the CUSC (e.g. where a User has been granted Short Term Transmission Entry Capacity, STTEC). For the avoidance of doubt, TNUoS Charges will be determined on the TEC held by a User as specified within a relevant bilateral agreement regardless of whether or not it enters into a temporary TEC Exchange (as defined in the CUSC).

14.18.11 The short-term chargeable capacity for Power Stations situated with positive generation tariffs is any approved STTEC or LDTEC applicable to that Power Station during a valid STTEC Period or LDTEC Period, as appropriate.

14.18.12 For Power Stations, the short term chargeable capacity for LDTEC with positive generation tariffs referred to in Paragraph 14.18.11, will be the capacity purchased either on a profiled firm<sup>2</sup> or indicative<sup>3</sup> basis and shall be assessed according to the capacity purchased on a weekly basis. The short-term chargeable capacity for LDTEC in any week may comprise of a number of increments, which shall be determined by considering LDTEC purchased previously in the Financial Year (whether or not in the same LDTEC Period). For example, if in a given week the LDTEC is 200MW but in a previous week the LDTEC had been 150MW, the short-term chargeable capacity in the latter week would comprise of two increments: one of 150MW and a second of 50MW. Further examples are provided in 14.16.6.

**Deleted:** 14.18.11

**Deleted:** 14.18.

#### Generation with negative wider tariffs

<sup>2</sup> where an LDTEC Block Offer has been accepted (Profiled Block LDTEC) and a firm profile of capacity has been purchased.

<sup>3</sup> where an LDTEC Indicative Block Offer has been accepted (Indicative Profiled Block LDTEC) and a right to future additional capacity up to a requested level has been purchased, the availability of which will be notified on a weekly basis in accordance with the CUSC.

14.18.13 The Chargeable Capacity for Power Stations with negative wider generation tariffs is the average of the capped metered volumes during the three settlement periods described in [14.18.14](#) below, for the Power Station (i.e. the sum of the metered volume of each BM Unit associated with Power Station in Appendix C of its Bilateral Agreement). A Power Station should not exceed its TEC as to do so would be in breach of the CUSC, except where it is entitled to do so under the specific circumstances laid out in the CUSC (e.g. where a User has been granted Short Term Transmission Entry Capacity). If TEC is exceeded, the metered volumes would each be capped by the TEC for the Power Station applicable for that Financial Year. For the avoidance of doubt, TNUoS Charges will be determined on the TEC held by a User as specified within a relevant bilateral agreement regardless of whether or not it enters into a temporary TEC Exchange (as defined in the CUSC).

Deleted: 14.18.14

Deleted: 14.18.

14.18.14 The three settlement periods are those of the highest metered volumes for the Power Station and the two half hour settlement periods of the next highest metered volumes which are separated from the highest metered volumes and each other by at least 10 Clear Days, between November and February of the relevant Financial Year inclusive. These settlement periods do not have to coincide with the Triad.

#### **Example**

If the highest TEC for a Power Station were **250MW** and the highest metered volumes and resulting capped metered volumes were as follows:

Date	19/11/08	13/12/08	06/02/09
Highest Metered Volume in month (MW)	<b>245.5</b>	<b>250.3</b>	<b>251.4</b>
Capped Metered Volume (MW)	<b>245.5</b>	<b>250.0</b>	<b>250.0</b>

Then, the chargeable Capacity for the Power Station would be:

$$\left( \frac{245.5 + 250 + 250}{3} \right) = \mathbf{248.5 \text{ MW}}$$

Note that in the example above, the Generator has exceeded its TEC on 13 December 2007 and 6 February 2008 and would therefore be in breach of the CUSC unless the generator had an approved STTEC or LDTEC value. (The STTEC and LDTEC charge for negative zones is currently set at zero).

14.18.15 The short-term chargeable capacity for Power Stations with negative generation tariffs is any approved STTEC or LDTEC applicable to that Power Station during a valid STTEC Period or LDTEC Period, as applicable.

14.18.16 For Power Stations with negative generation tariffs, the short-term chargeable capacity for LDTEC referred to in Paragraph 14.18.14 will be the capacity purchased either on a profiled firm or indicative basis and shall be assessed according to the capacity purchased on a weekly basis. The short-term chargeable capacity for LDTEC in any week may comprise of a number of increments, which shall be determined by considering LDTEC purchased previously in the Financial Year (whether or not in the same LDTEC Period). For example, if in a given week the LDTEC is 200MW but in a previous week the LDTEC had been 150MW, the short-term chargeable capacity in the latter week would comprise of two increments: one of 150MW and a second at 50MW.

- 14.18.17 As noted above, a negative LDTEC tariff in negative generation charging zones is set to zero. Accordingly no payments will be made for use of LDTEC (in any of its forms) in these zones.

### Basis of Local Generation Charges

- 14.18.18 The Chargeable Capacity for Power Stations will be the same as that used for wider generation charges, except that each component of the local tariff shall be considered separately as to whether it is a positive or negative tariff component. This means that where a local circuit tariff is negative, the final charging liability for this element will be based on actual metered output as described in Paragraph 14.18.12.

### Small Generators Charges

- 14.18.19 Eligible small generators' tariffs are subject to a discount of a designated sum defined by Licence Condition C13 as 25% of the combined residual charge for generation and demand. The calculation for small generators charges is not part of the methodology however, for information the designated sum is included in **The Statement of Use of System Charges**.

### Monthly Charges

- 14.18.20 Initial Transmission Network Use of System Generation Charges for each Financial Year will be based on the Power Station Transmission Entry Capacity (TEC) for each User as set out in their Bilateral Agreement. The charge is calculated as above. This annual TNUoS generation charge is split evenly over the months remaining in the year. For positive final generation tariffs, if TEC increases during the charging year, the party will be liable for the additional charge incurred for the **full** year, which will be recovered uniformly across the remaining chargeable months in the relevant charging year (subject to Paragraph 14.18.20 below). An increase in monthly charges reflecting an increase in TEC during the charging year will result in interest being charged on the differential sum of the increased and previous TEC charge. The months liable for interest will be those preceding the TEC increase from April in year t. For negative final generation tariff, any increase in TEC during the year will lead to a recalculation of the monthly charges for the remaining chargeable months of the relevant charging year. However, as TEC decreases do not become effective until the start of the financial year following approval, no recalculation is necessary in these cases. As a result, if TEC increases, monthly payments to the generator will increase accordingly.
- 14.18.21 The provisions described above for increases in TEC during the charging year shall not apply where the LDTEC (in any of its forms) has been approved for use before the TEC is available, which will typically mean the LDTEC has been approved after the TEC increase has been approved. In such instances, the party shall commence payments for TEC during the LDTEC Period for LDTEC purchased up to the future level of TEC and LDTEC Charges will only apply to LDTEC that is incremental to the TEC increase. For the avoidance of doubt, where TEC has been approved after LDTEC in a given year, these provisions shall not apply and the LDTEC shall be considered additional to the TEC and charged accordingly.

### Ad hoc Charges

- 14.18.22 For each STTEC period successfully applied for, a charge will be calculated by multiplying the STTEC by the tariff calculated in accordance with Paragraph 14.16.3. The Company will invoice Users for the STTEC charge once the application for STTEC is approved.

Deleted: .

14.18.23 For Power Stations utilising LDTEC (in any of its forms) the LDTEC Charge for each LDTEC Period is the sum of the charging liabilities associated with each incremental level of short term chargeable capacity provided by LDTEC within the LDTEC Period (assessed on a weekly basis). The charging liability for a given incremental level of short term chargeable capacity is the sum of:

- i) the product of the higher tariff rate (calculated in accordance with Paragraph 14.16.6) and capacity purchased at this increment for the first 17 weeks in a Financial Year (whether consecutive or not); and
- ii) the product of the lower tariff rate (calculated in accordance with Paragraph 14.16.6) and capacity purchased at this increment in any additional weeks within the same Financial Year (whether consecutive or not).

14.18.24 For each LDTEC Period successfully applied for, the LDTEC Charge will be split evenly over the relevant LDTEC Period and charged on a monthly basis. LDTEC charges will apply to both LDTEC (in any of its forms) and Temporary Received TEC held by a User. For the avoidance of doubt, the charging methodology will not differentiate between access rights provided to a generator by LDTEC or through Temporary Received TEC obtained through a Temporary TEC Exchange (as defined in the CUSC).

**Example**

The diagrams below show two cases where LDTEC has been purchased: in Case A, two LDTEC Periods have been purchased; and in Case B one LDTEC Period has been purchased. The total capacity purchased in both cases is the same. The top diagrams illustrate the capacity purchased, while lower diagrams illustrate the incremental levels of short term chargeable capacities of LDTEC and the tariff rate that would apply to that capacity.

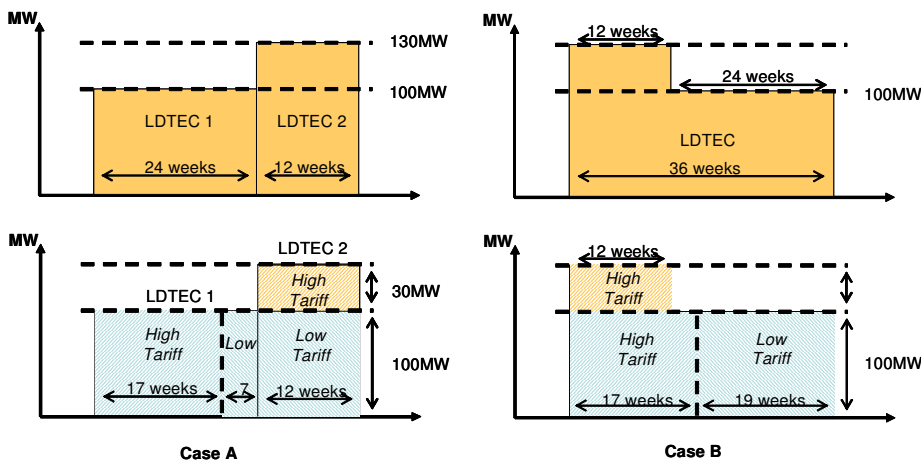

In both cases, the total amount charged for the LDTEC would be the same:

Capacity charges at the higher tariff rate:

- 17 weeks at the 100MW increment
- 12 weeks at the 30MW increment

Capacity charges at the lower tariff rate:

- 19 weeks at the 100MW increment

**Formatted:** Indent: Left: 0 cm, Hanging: 0.44 cm, Bulleted + Level: 1 + Aligned at: 0 cm + Tab after: 0.63 cm + Indent at: 0.63 cm, Tabs: 0.44 cm, List tab + Not at 0.63 cm + 1.27 cm

**Formatted:** Indent: Left: 0 cm, Hanging: 0.47 cm, Bulleted + Level: 1 + Aligned at: 0 cm + Tab after: 0.63 cm + Indent at: 0.63 cm, Tabs: 0.47 cm, List tab + Not at 0.63 cm + 1.27 cm

**Embedded Transmission Use of System Charges “ETUoS”**

- 14.18.25 The ETUoS charges are a component of Use of System charges levied on offshore generators whose offshore transmission connection is embedded in an onshore distribution network. The charge relates to the provision and use of the onshore distribution network.
- 14.18.26 The main purpose of ETUoS charges is to pass through the charges that are levied by the DNO on the NETSO to the offshore generator(s). This charge reflects the charges levied by the DNO for the costs of any works on and use of the DNO network in accordance with the DNO’s charging statements and will include, but is not limited to, upfront charges and capital contributions in respect of any works as well as the ongoing and annual Use of System charges for generation connected to the distribution network.
- 14.18.27 In the case of some relevant transitional offshore generation projects, ETUoS will also be used to pass through historic DNO capital contributions forming part of the Offshore Transmission Owner tender revenue stream.
- 14.18.28 The specific nature of the ETUoS charge and the payment profile for these will depend upon the charging arrangements of the relevant DNO and reference should be made to the relevant DNO’s charging statement. In terms of applicable transitional offshore generation projects the ETUoS payment profile will be consistent with the recovery of the Offshore Transmission Owner revenue stream.
- 14.18.29 Where a DNO’s charge relates to more than one offshore generator, the related ETUoS charge will represent a straight pass through of the distribution charge specific to each relevant offshore generator. Where specific information is not available, charges will be pro-rated based on the TEC of the relevant offshore generators connected to that offshore network.
- 14.18.30 Invoices for ETUoS charges shall be levied by the NETSO on the offshore generator as soon as reasonably practicable after invoices have been received by the NETSO for payment such that the NETSO can meet its payment obligations to the DNO. The initial payments and payment dates will be outlined in a User’s Construction Agreement and/or Bilateral Agreement.
- 14.18.31 As the ETUoS charges reflect the DNO charges to the NETSO, such charges will be subject to variation when varied by the DNO. Where the User disputes regarding the ETUoS charge please note that this will result in a dispute between the NETSO and DNO under the DCUSA.

**Reconciliation of Generation Charges**

- 14.18.32 The reconciliation process is set out in the CUSC and in line with the principles set out above.
- 14.18.33 In the event of a manifest error in the calculation of TNUoS charges which results in a material discrepancy in a User’s TNUoS charge as defined in Sections 14.17.27 to 14.17.29, the generation charges of Users qualifying under Section 14.17.28 will be reconciled in line with [14.18.20](#) and [14.18.25](#) using the recalculated tariffs.

**Further Information**

- 14.18.34 **The Statement of Use of System Charges** contains the £/kW generation zonal tariffs for the current Financial Year.

Deleted: 14.18.20

Deleted: 14.18.

Deleted: 14.18.25

Deleted: 14.18.



## 14.19 Data Requirements

### Data Required for Charge Setting

- 14.19.1 Users who are Generators or Interconnector Asset Owners provide to The Company a forecast for the following Financial Year of the highest Transmission Entry Capacity (TEC) applicable to each Power Station or Interconnector for that Financial Year. For Financial Year 2008/9 Scottish Generators or Interconnector Asset Owners provide to The Company a forecast of the equivalent highest 'export' capacity figure. This data is required by The Company as the basis for setting TNUoS tariffs. The Company may request these forecasts in the November prior to the Financial Year to which they relate, in accordance with the CUSC. Additionally users who are Generators provide to The Company details of their generation plant type.
- 14.19.2 Users who are owners or operators of a User System (e.g. Distribution companies) provide a forecast for the following Financial Year of the Natural Demand attributable to each Grid Supply Point equal to the forecasts of Natural Demand under both Annual Average Cold Spell (ACS) Conditions and a forecast of the average metered Demand attributable to such Grid Supply Point for the National Grid Triad. This data is published in table 2.4 of the Seven Year Statement and is compiled from week 24 data submitted in accordance with the Grid Code.
- 14.19.3 For the following Financial Year, The Company shall use these forecasts as the basis of Transmission Network Use of System charges for such Financial Year. A description of how this data is incorporated is included in 14.15 Derivation of the Transmission Network Use of System Tariff.
- 14.19.4 If no data is received from the User, then The Company will use the best information available for the purposes of calculation of the TNUoS tariffs. This will normally be the forecasts provided for the previous Financial Year.

### Data Required for Calculating Users' Charges

- 14.19.5 In order for The Company to calculate Users' TNUoS charges, Users who are Suppliers shall provide to The Company forecasts of half-hourly and non-half-hourly demand in accordance with paragraph 14.17.14 and 14.17.15 and in accordance with the CUSC.

## 14.20 Applications

14.20.1 Application fees are payable in respect of applications for new Use of System agreements; modifications to existing agreements; and applications for short-term access products or services. These are based on the reasonable costs that transmission licensees incur in processing these applications.

### Applications for short-term access

14.20.2 Application fees for short-term access products or services are fixed and detailed in the **Statement of Use of System Charges**. These are non-refundable except for the following limited instances:

- Where a User (or Users) withdraw their application in accordance with any interactivity provisions that may be contained within the CUSC; or
- Where the application fee covers ongoing assessment work that is contingent on the acceptance of the offer.

14.20.3 In either case, the refunded amount will be proportional to the remaining assessment time available.

14.20.4 To ensure that application fees for short-term access are cost reflective, fees may be comprised of a number of components. For instance, the LDTEC Request Fee is comprised of a number of components and the total fee payable is the sum of those components that apply to the type(s) of LDTEC Offer(s) requested. For example:

- The LDTEC Request Fee for an LDTEC Block Offer is the basic request fee.
- The LDTEC Request Fee for an LDTEC Indicative Block Offer is the sum of the basic request fee and the additional rolling assessment fee.
- The LDTEC Request Fee payable for a combined LDTEC Block Offer and LDTEC Indicative Block Offer is the sum of the basic request fee, the additional rolling assessment fee, and the additional combined application fee.

**Formatted:** Indent: Left: 2.87 cm, Hanging: 0.75 cm, Bulleted + Level: 1 + Aligned at: 0 cm + Tab after: 0.63 cm + Indent at: 0.63 cm, Tabs: 3.62 cm, List tab + Not at 0.63 cm + 1.27 cm

**Formatted:** Indent: Left: 2.87 cm, Hanging: 0.75 cm, Bulleted + Level: 1 + Aligned at: 0 cm + Tab after: 0.63 cm + Indent at: 0.63 cm, Tabs: 3.62 cm, List tab + Not at 0.63 cm + 1.27 cm

**Formatted:** Indent: Left: 2.87 cm, Hanging: 0.75 cm, Bulleted + Level: 1 + Aligned at: 0 cm + Tab after: 0.63 cm + Indent at: 0.63 cm, Tabs: 3.62 cm, List tab + Not at 0.63 cm + 1.27 cm

### Applications for new or modified existing Use of System Agreements

14.20.5 Users can opt to pay a fixed price application fee in respect of their application or pay the actual costs incurred. The fixed price fees for applications are detailed in the **Statement of Use of System Charges**.

14.20.6 If a User chooses not to pay the fixed fee, the application fee will be based on an advance of transmission licensees' Engineering and out-of pocket expenses and will vary according to the size of the scheme and the amount of work involved. Once the associated offer has been signed or lapsed, a reconciliation will be undertaken. Where actual expenses exceed the advance, The Company will issue an invoice for the excess. Conversely, where The Company does not use the whole of the advance, the balance will be returned to the User.

14.20.7 The Company will refund the first application fee paid (the fixed fee or the amount post-reconciliation) and consent payments made under the Construction Agreement for new or modified existing agreements. The refund shall be made either on commissioning or against the charges payable in the first three years of the new or modified agreement. The refund will be net of external costs.

- 14.20.8 The Company will not refund application fees for applications to modify a new agreement or modified existing agreement at the User's request before any charges become payable. For example, The Company will not refund an application fee to delay the provision of a new connection if this is made prior to charges becoming payable.

### 14.21 Transport Model Example

For the purposes of the DCLF Transport algorithm, it has been assumed that the value of circuit impedance is equal to the value of circuit reactance.

Consider the following 3-node network:

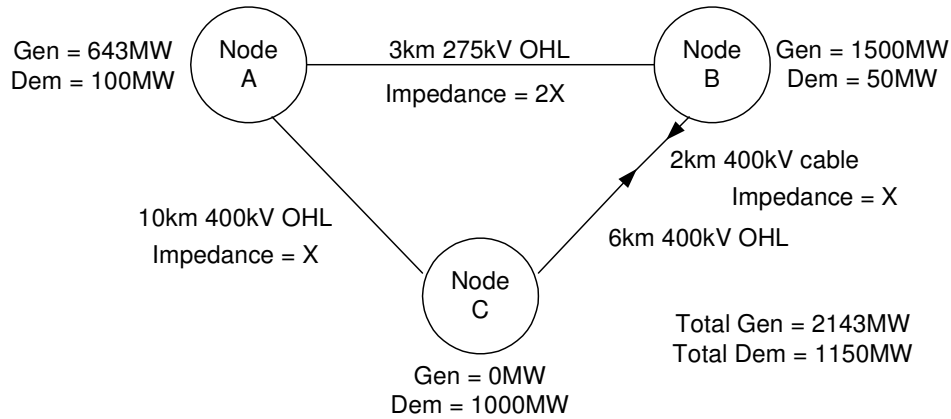

➔ Denotes cable

The first step is to match total demand and total generation by scaling uniformly the nodal generation down such that total system generation equals total system demand.

Node A Generation =  $1150/1495 * 650\text{MW} = 500\text{MW}$

Node B Generation =  $1150/1495 * 845\text{MW} = 650\text{MW}$

This gives the following balanced system:

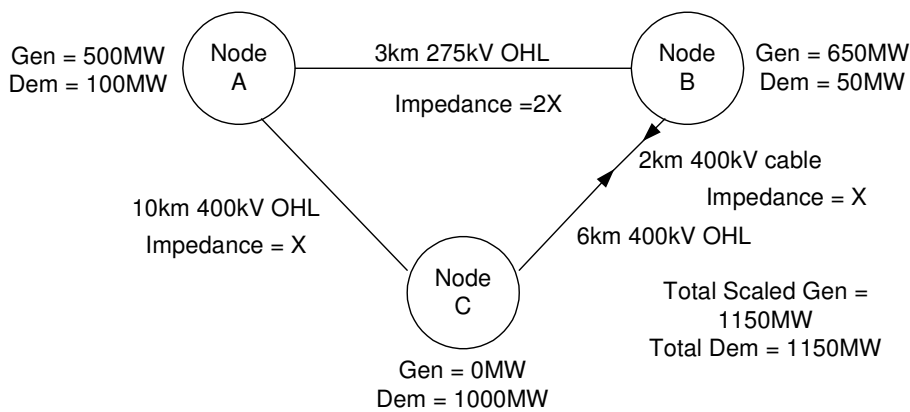

Assuming Node A is the reference node, each circuit has impedance X the 400kV cable circuit expansion factor is 10 and the 275kV overhead line circuit expansion factor is 2, the DCLF transport algorithm calculates the base case power flows as follows:

Deleted: ¶  
Formatted: Font: Times New Roman, 12 pt

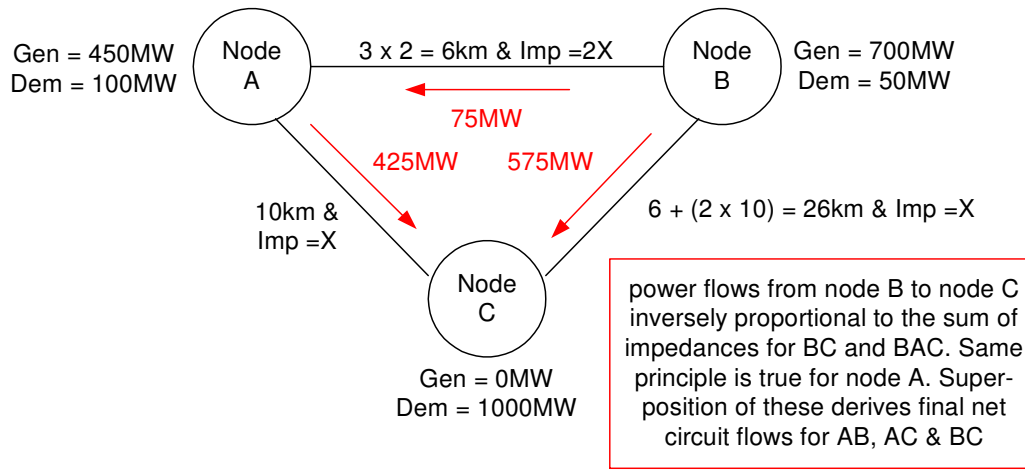

Nodes A and B export, whilst Node C imports. Hence the DCLF algorithm derives flows to deliver export power from Nodes A and B to meet import needs at Node C.

Formatted: Font: Arial  
Formatted: Body Text 2, Justified

Step 1: Net export from Node A is 400MW; route AC has impedance X and route AB-BC has impedance 3X; hence 300MW would flow down AC and 100MW along AB-BC

Step 2: Net export from Node B is 600MW; route BC has impedance X and route BA-AC has impedance 3X; hence 450MW would flow down BC and 150MW along BA-AC

Step 3: Using super-position to add the flows derived in Steps 1 and 2 derives the following;

Flow AC	=	300MW + 150MW	=	450MW
Flow AB	=	100MW - 150MW	=	-50MW
Flow BC	=	100MW + 450MW	=	550MW

Total cost =  $(450 \times 10) + (50 \times 6) + (550 \times 26) = 19,100$  MWkm (base case)

We then 'inject' 1MW of generation at each node with a corresponding 1MW offtake (demand) at the reference node and recalculate the total MWkm cost. The difference in cost from the base case is the marginal km or shadow cost. This is demonstrated as follows:

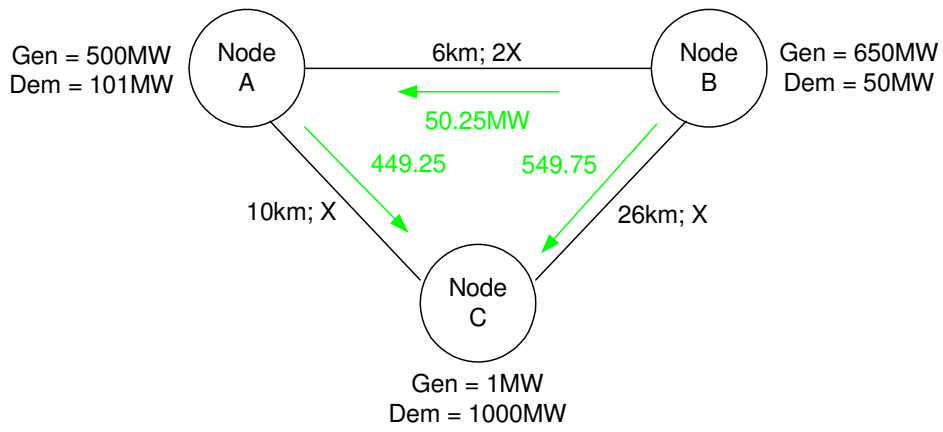

To calculate the marginal km at node C:

$$\text{Total Cost} = (449.25 \times 10) + (50.25 \times 6) + (549.75 \times 26) = 19,087.5 \text{ MWkm}$$

Thus the overall cost has reduced by 12.5 (i.e. the marginal km = -12.5).

Deleted: ¶

Formatted: Normal

### 14.22 Illustrative Calculation of Boundary Sharing Factors (BSFs) and Not-Shared incremental km

The following illustrative example shows how the boundary sharing factors and not-shared incremental km are calculated for the transmission system described in the table below.

Generation Charging Zone	A	B	C	D
Zonal MWkm	450	350	150	100

The diagram below shows the expanded connectivity of this transmission system.

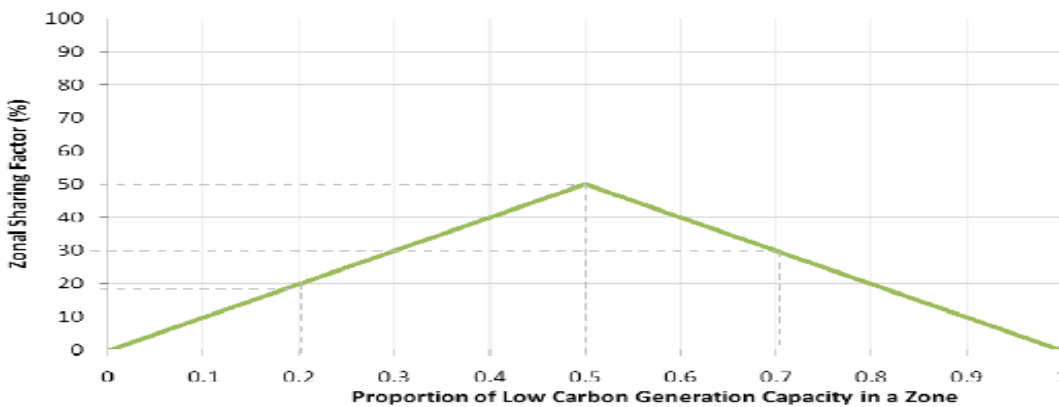
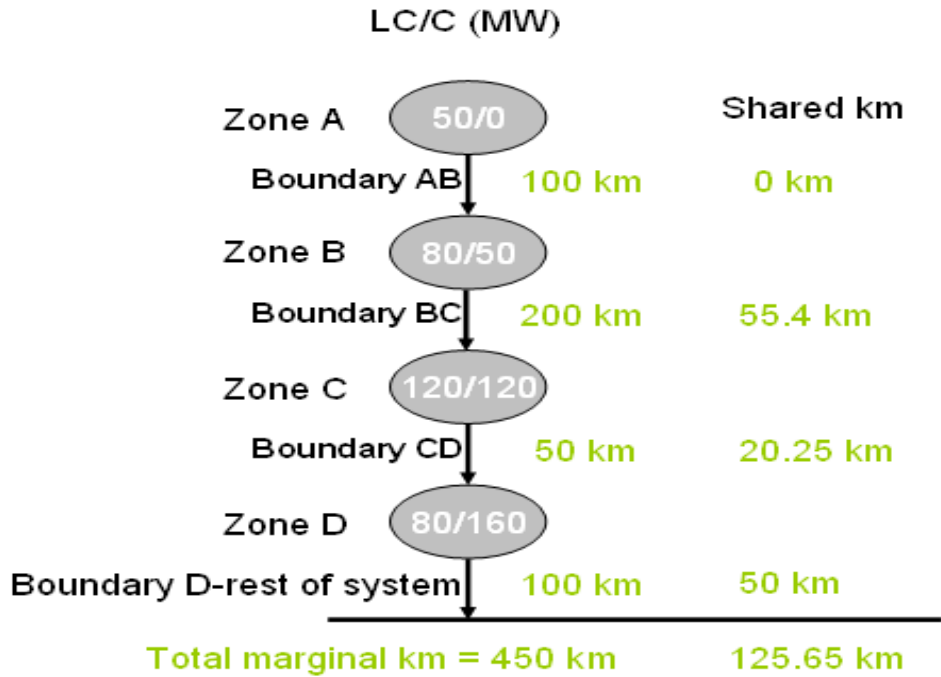

The above figure illustrates how BSFs are derived and shared incremental km are calculated.

- Formatted: Font: 15 pt, Highlight
- Deleted: Sharing of Year Round Marginal km costs
- Formatted: Highlight
- Formatted: Font: 15 pt, Highlight
- Formatted: Highlight
- Formatted: Highlight
- Formatted: ... [139]
- Formatted: Normal
- Formatted: ... [140]
- Formatted: Highlight
- Formatted: ... [141]
- Formatted: ... [142]
- Formatted: ... [143]
- Formatted: ... [144]
- Formatted: ... [145]
- Formatted: ... [146]
- Formatted: ... [147]
- Formatted: ... [148]
- Formatted: ... [149]
- Formatted: ... [150]
- Formatted: ... [151]
- Formatted: ... [152]
- Formatted: ... [153]
- Formatted: ... [154]
- Formatted: ... [155]
- Formatted: ... [156]
- Formatted: ... [157]
- Formatted: ... [158]
- Formatted: ... [159]
- Formatted: ... [160]
- Formatted: ... [161]
- Formatted: Normal
- Formatted: ... [162]
- Formatted: ... [163]
- Formatted: ... [164]
- Formatted: Normal
- Formatted: ... [165]
- Formatted: ... [166]
- Formatted: Highlight
- Deleted: ZSF is
- Formatted: Highlight
- Formatted: Highlight
- Formatted: Highlight
- Formatted: Highlight
- Deleted: boundary lengths
- Formatted: Highlight
- Formatted: Highlight

(a) For Boundary AB (where 50MW of the generation is Low Carbon (LC) and 0MW of the generation is Carbon (C) and Year Round zonal marginal km = 100km) -

Calculate the BSF using the following formula -

$$BSF = \text{Minimum} \left( \frac{LC}{LC+C}, \frac{C}{LC+C} \right) = \text{Minimum} \left( \frac{50}{50+0}, \frac{0}{50+0} \right)$$

Therefore BSF = 0%

Shared incremental km = 0% \* 100km = 0km

Not-shared incremental km = 100 - 0 = 100km

(b) For Boundary BC (where 130MW of the generation is Low Carbon (LC) and 50MW of the generation is Carbon (C) and Year Round boundary marginal km = 200km) -

Calculate the BSF using the following formula -

$$BSF = \text{Minimum} \left( \frac{LC}{LC+C}, \frac{C}{LC+C} \right) = \text{Minimum} \left( \frac{(50+80)}{(50+80)+(0+50)}, \frac{(0+50)}{(50+80)+(0+50)} \right)$$

$$= \text{Minimum} \left( \frac{130}{180}, \frac{50}{180} \right) = 0.277 \text{ (27.77\%)}$$

Therefore BSF = 27.77%

Shared incremental km = 0.277 \* 200km = 55.4km

Not-shared incremental km = 200 - 55.4 = 144.6km

(c) For Boundary CD (where 250MW of the generation is Low Carbon (LC) and 170MW of the generation is Carbon (C) and Year Round boundary marginal km = 50km) -

Calculate the BSF using the following formula -

$$BSF = \text{Minimum} \left( \frac{LC}{LC+C}, \frac{C}{LC+C} \right)$$

$$= \text{Minimum} \left( \frac{(50+80+120)}{(50+80+120)+(0+50+120)}, \frac{(0+50+120)}{(50+80+120)+(0+50+120)} \right)$$

$$= \text{Minimum} \left( \frac{250}{420}, \frac{170}{420} \right) = 0.405 \text{ (40.5\%)}$$

Therefore BSF = 40.5%

Shared boundary incremental km = 0.405 \* 50km = 20.25km

Not-shared incremental km = 50 - 20.25 = 29.75km

Formatted ... [167]  
 Formatted ... [168]  
 Formatted ... [169]  
 Formatted ... [170]  
 Formatted ... [171]  
 Deleted: Z  
 Formatted ... [172]  
 Formatted ... [173]  
 Formatted ... [174]  
 Formatted ... [175]  
 Formatted ... [176]  
 Formatted ... [177]  
 Formatted ... [178]  
 Deleted: Z  
 Formatted ... [179]  
 Formatted ... [180]  
 Formatted ... [181]  
 Deleted: marginal  
 Formatted ... [182]  
 Formatted ... [183]  
 Formatted ... [184]  
 Formatted ... [185]  
 Deleted: The length d ... [186]  
 Formatted ... [187]  
 Formatted ... [188]  
 Formatted ... [189]  
 Deleted: zona...  
 Formatted ... [191]  
 Formatted ... [192]  
 Formatted ... [193]  
 Deleted: Z  
 Formatted ... [194]  
 Formatted ... [195]  
 Formatted ... [196]  
 Formatted ... [197]  
 Formatted ... [198]  
 Formatted ... [199]  
 Deleted: Z  
 Formatted ... [200]  
 Formatted ... [201]  
 Deleted: marginal  
 Formatted ... [202]  
 Formatted ... [203]  
 Formatted ... [204]  
 Deleted: The length d ... [205]  
 Formatted ... [206]  
 Formatted ... [207]  
 Formatted ... [208]  
 Deleted: zonal  
 Formatted ... [209]  
 Formatted ... [210]  
 Deleted: Z  
 Formatted ... [211]  
 Formatted ... [212]  
 Formatted ... [213]  
 Formatted ... [214]  
 Formatted ... [215]  
 Formatted ... [216]  
 Formatted ... [217]  
 Formatted ... [218]  
 Formatted ... [219]  
 Formatted ... [220]  
 Formatted ... [221]



(d) For **Boundary D – Rest of System** (where 20MW of the generation is Low Carbon (LC) and 80MW of the generation is Carbon (C) and Year Round **boundary marginal km = 100km**) -

Calculate the **BSF** using the following formula -

$$BSF = \text{Minimum} \left( \frac{LC}{LC+C}, \frac{C}{LC+C} \right)$$

$$= \text{Minimum} \left( \frac{(50 + 80 + 120 + 80)}{(50 + 80 + 120 + 80) + (0 + 50 + 120 + 160)}, \frac{(0 + 50 + 120 + 160)}{(50 + 80 + 120 + 80) + (0 + 50 + 120 + 160)} \right)$$

$$= \text{Minimum} \left( \frac{330}{660}, \frac{330}{660} \right) = 0.5 \text{ (50\%)}$$

Therefore **BSF = 50%**

**Shared boundary incremental km = 0.5 \* 100km = 50km**

**Not-shared incremental km = 100 - 50 = 50km**

The **not-shared zonal marginal km** for each generation charging zone will be the sum of the relevant **not-shared boundary marginal km**, as shown in the table below (assuming the node below D is the centre of the system i.e. zonal MWkm of 0). These **not-shared zonal incremental km** are then use to calculate wider £/kW generation tariffs.

<b>Boundary/Zone</b>	<b>A</b>	<b>B</b>	<b>C</b>	<b>D</b>
<b>A-B</b>	100			
<b>B-C</b>	144.6	144.6		
<b>C-D</b>	29.75	29.75	29.75	
<b>D-rest of system</b>	50	50	50	50
<b>Not-Shared Zonal MWkm</b>	324.35	224.35	79.75	50
<b>Total Zonal MWkm</b>	450	350	150	100

- Deleted: Zone ... [224]
- Formatted ... [225]
- Deleted: zonal ... [226]
- Formatted ... [227]
- Deleted: Z ... [228]
- Formatted ... [229]
- Formatted ... [230]
- Formatted ... [231]
- Formatted ... [232]
- Formatted ... [233]
- Formatted ... [234]
- Deleted: Z ... [235]
- Formatted ... [236]
- Formatted ... [237]
- Deleted: marginal ... [238]
- Formatted ... [239]
- Formatted ... [240]
- Deleted: The length of ... [241]
- Formatted ... [242]
- Formatted ... [243]
- Formatted ... [244]
- Deleted: MW...se... [245]
- Formatted ... [246]
- Formatted ... [247]
- Formatted ... [248]
- Formatted ... [249]
- Formatted ... [250]
- Formatted ... [251]
- Formatted ... [252]
- Formatted ... [253]
- Formatted ... [254]
- Formatted ... [255]
- Formatted ... [256]
- Formatted ... [257]
- Formatted ... [258]
- Formatted ... [259]
- Deleted: 100 ... [260]
- Formatted ... [261]
- Formatted ... [262]
- Formatted ... [263]
- Deleted: 144.6 ... [264]
- Formatted ... [265]
- Deleted: 144.6 ... [266]
- Formatted ... [267]
- Formatted ... [268]
- Formatted ... [269]
- Deleted: 29.75 ... [270]
- Formatted ... [271]
- Formatted ... [272]
- Formatted ... [273]
- Formatted ... [274]
- Formatted ... [275]
- Formatted ... [276]
- Formatted ... [277]

### 14.23 Example: Calculation of Zonal Generation Tariff

Deleted: 2

Let us consider all nodes in a generation zone in this example.

Deleted: 4

The table below shows a sample output of the transport model comprising the node, the wider nodal marginal km (observed on non-local assets) of an injection at the node with a consequent withdrawal at the reference node, the generation sited at the node, scaled to ensure total national generation equals total national demand.

Genzone	Node	Wider Nodal Marginal km	Scaled Generation
4	LAGG1Q	1113.41	0.00
4	CEAN1Q	1133.18	54.41
4	FASN10	1143.82	38.50
4	FAUG10	1100.10	0.00
4	FWIL1Q	1009.79	0.00
4	FWIL1R	1009.79	0.00
4	GLEN1Q	1123.82	43.52
4	INGA1Q	1087.40	16.74
4	MILL1Q	1101.55	0.00
4	MILL1S	1106.76	0.00
4	QUOI10	1123.82	15.07
4	QUOI1Q	<b>1120.49</b>	0.00
4	LOCL1Q	<b>1082.41</b>	0.00
4	LOCL1R	<b>1082.41</b>	0.00
	<b>Totals</b>		168.24

In order to calculate the generation tariff we would carry out the following steps.

- (i) calculate the generation weighted wider nodal shadow costs.

Formatted: Bullets and Numbering

For this example zone this would be as follows:

Deleted: 4

Genzone	Node	Wider Nodal Marginal km	Scaled Generation (MW)	Gen Weighted Wider Nodal Marginal km
4	CEAN1Q	1133.18	54.41	366.48
4	FASN10	1143.82	38.50	261.75
4	GLEN1Q	1123.82	43.52	290.71
4	INGA1Q	1087.40	16.74	108.20
4	QUOI10	1123.82	15.07	100.67
	<b>Totals</b>		168.24	

i.e.  $1087.40 \times 16.74$   
168.24

(ii) sum the generation weighted wider nodal shadow cost to give a zonal figure.  
For zone 4 this would be:

$$(366.48 + 261.75 + 290.71 + 108.20 + 100.67) \text{ km} = \mathbf{1127.81 \text{ km}}$$

(iii) calculate the not-shared zonal incremental km for zone 4. In this example it is assumed that this is 789.5km.

(iv) calculate the initial wider transport tariff by multiplying the figure in (iii) above by the expansion constant and locational security factor (& dividing by 1000 to put into units of £/kW).

For this example zone assuming an expansion constant of £10.07/MWkm and a locational security factor of 1.8:

$$\frac{789.5 \text{ km} * \text{£}10.07/\text{MWkm} * 1.8}{1000} = \mathbf{\text{£}14.31/\text{kW}}$$

(v) If we assume (for the sake of this example) that the generation connecting at CEAN1Q connects via 10km of 132kV 100MVA rated single circuit overhead line from the nearest MITS node, with no redundancy, the substation is rated at less than 1320MW, and there is no other generation or demand connecting to this circuit, then:

a) referencing the table in paragraph 14.15.67, the local substation tariff will be £0.133/kW; and

b) running the transport model with a local circuit expansion factor of 10.0 applied to the 10km of overhead line connecting CEAN1Q to the nearest MITS node and the wider circuit expansion factors applied to all other circuits, gives a local nodal marginal cost of 100MWkm. This is the additional MWkm costs associated with the node's local assets. Applying the expansion constant of £10.07/MWkm and local security factor of 1.0 and dividing by 1000 gives a local circuit tariff of £1.007/kW.

(vi) We now need to calculate the residual tariff. This is calculated by taking the total revenue to be recovered from generation (calculated as c.27% of total The Company TNUoS target revenue for the year) less the revenue which would be recovered through the generation transport tariffs divided by total expected generation.

Assuming the total revenue to be recovered from TNUoS is £1067m, the total recovery from generation would be (27% \* £1067m) = £288m. Assuming the total recovery from both wider generation transport and local generation tariffs is £70m and total forecast chargeable generation capacity is 67000MW, the Generation residual tariff would be as follows:

$$\frac{\text{£}288 - \text{£}70\text{m}}{65000\text{MW}} = \mathbf{\text{£}3.35/\text{kW}}$$

(vii) Therefore the charges for thermal plant with a TEC of 100MW:

- = Wider Tariff \* TEC
- = Local substation Tariff \* TEC
- = Local circuit Tariff \* TEC
- = Residual Tariff \* TEC

For this example, the above charges are –

Formatted	...	[281]
Formatted	...	[282]
Formatted	...	[283]
Formatted	...	[284]
Formatted	...	[285]
Deleted: 4 and		
Deleted: 888.21		
Formatted	...	[286]
Formatted	...	[287]
Formatted	...	[288]
Formatted	...	[289]
Deleted: 6		
Deleted: 10		
Deleted: ¶	...	[290]
Formatted	...	[291]
Formatted	...	[292]
Formatted	...	[293]
Formatted	...	[294]
Formatted	...	[295]
Formatted	...	[296]
Formatted: Bullets and Numbering	...	[297]
Formatted: Bullets and Numbering	...	[298]
Formatted	...	[299]
Deleted: and a ZSF	...	[300]
Formatted	...	[301]
Formatted	...	[302]
Formatted	...	[303]
Deleted: (1-ZSF) *		
Formatted	...	[304]
Formatted	...	[305]
Formatted	...	[306]
Formatted	...	[307]
Formatted	...	[308]
Formatted	...	[309]
Formatted	...	[310]
Formatted	...	[311]
Formatted	...	[312]
Formatted	...	[313]
Formatted	...	[314]
Formatted	...	[315]
Formatted	...	[316]
Formatted	...	[317]
Formatted	...	[318]
Formatted	...	[319]
Formatted	...	[320]
Formatted	...	[321]
Formatted	...	[322]
Formatted	...	[323]
Formatted	...	[324]
Formatted	...	[325]



## 14.24 Example: Calculation of Zonal Demand Tariff

Let us consider all nodes in a demand zone in this example.

The table below shows a sample output of the transport model comprising the node, the marginal km of an injection at the node with a consequent withdrawal at the reference node, the generation sited at the node, scaled to ensure total national generation = total national demand and the demand sited at the node.

Deleted: ¶

¶

Deleted: 3

Deleted: 14: South Western.

<u>Demand Zone</u>	<u>Node</u>	<u>Nodal Marginal km</u>	<u>Demand (MW)</u>
14	ABHA4A	-381.25	148.5
14	ABHA4B	-381.72	148.5
14	ALVE4A	-328.31	113
14	ALVE4B	-328.31	113
14	AXMI40 SWEB	-337.53	117
14	BRWA2A	-281.64	92.5
14	BRWA2B	-281.72	92.5
14	EXET40	-320.12	357
14	HINP20	-247.67	4
14	HINP40	-247.67	0
14	INDQ40	-401.28	450
14	IROA20 SWEB	-194.88	594
14	LAND40	-438.65	297
14	MELK40 SWEB	-162.96	102
14	SEAB40	-63.21	352
14	TAUN4A	-273.79	0
14	TAUN4B	-273.79	97
	<b>Totals</b>		<b>3078</b>

In order to calculate the demand tariff we would carry out the following steps:

- (i) calculate the demand weighted nodal shadow costs

Formatted: Bullets and Numbering  
Deleted: 14

For this example zone this would be as follows:

Demand zone	Node	Nodal Marginal km	Demand (MW)	Demand Weighted Nodal Marginal km
14	ABHA4A	-381.25	148.5	-18.39
14	ABHA4B	-381.72	148.5	-18.42
14	ALVE4A	-328.31	113	-12.05
14	ALVE4B	-328.31	113	-12.05
14	AXMI40 SWEB	-337.53	117	-12.83
14	BRWA2A	-281.64	92.5	-8.46
14	BRWA2B	-281.72	92.5	-8.47
14	EXET40	-320.12	357	-37.13
14	HINP20	-247.67	4	-0.32
14	INDQ40	-401.28	450	-58.67
14	IROA20 SWEB	-194.88	594	-37.61
14	LAND40	-438.65	297	-42.33
14	MELK40 SWEB	-162.96	102	-5.40
14	SEAB40	-63.21	352	-7.23
14	TAUN4B	-273.79	97	-8.63
	Totals		3078	287.99

- (ii) sum the demand weighted nodal shadow cost to give a zonal figure. For zone 14 this is shown in the above table and is 287.99km.

Formatted: Bullets and Numbering

- (iii) modify the zonal figure in (ii) above by the generation/demand split correction factor. This ensures that the 27:73 (approximate) split of revenue recovery between generation and demand is retained.

Formatted: Bullets and Numbering

For this example zone this would be say:

Deleted: 14

$$287.99\text{km} - (-239.60\text{km}) = 527.59 \text{ km}$$

This value is the generation/demand split correction factor. It is calculated by simultaneous equations to give the correct split of total revenue.

- (iv) calculate the transport tariff by multiplying the figure in (iii) above by the expansion constant (& dividing by 1000 to put into units of £/kW):

Formatted: Bullets and Numbering

For zone 14, assuming an expansion constant of £10.07/MWkm and a locational security factor of 1.80:

$$\frac{527.59\text{km} * £10.07/\text{MWkm} * 1.8}{1000} = £9.56/\text{kW}$$

(v) We now need to calculate the residual tariff. This is calculated by taking the total revenue to be recovered from demand (calculated as c.73% of total The Company TNUoS target revenue for the year) less the revenue which would be recovered through the demand transport tariffs divided by total expected demand.

Assuming the total revenue to be recovered from TNUoS is £1067m, the total recovery from demand would be (73% x £1067m) = £779m. Assuming the total recovery from demand transport tariffs is £130m and total forecast chargeable demand capacity is 50000MW, the demand residual tariff would be as follows:

$$\frac{£779m - £130m}{50000MW} = £12.98/kW$$

(vi) to get to the final tariff, we simply add on the demand residual tariff calculated in (v) to the zonal transport tariff calculated in (iv)

For this example zone;

$$£9.56/kW + £12.98/kW = £22.54/kW$$

To summarise, in order to calculate the demand tariffs, we evaluate a demand weighted zonal marginal km cost, modify by a re-referencing quantity to ensure that our revenue recovery split between generation and demand is correct, then we add a constant (termed the residual cost) to give the overall tariff.

(vii) The final demand tariff is subject to further adjustment to allow for the minimum £0/kW demand charge. The application of a discount for small generators pursuant to Licence Condition C13 will also affect the final demand tariff.

- Formatted: Bullets and Numbering
- Formatted: Bullets and Numbering
- Deleted: 14
- Deleted: .....Page Break.....  
14.22 Example: Calculation of Zonal Generation Tariff¶  
¶  
Let us consider all nodes in generation zone 4: Western Highland.¶  
¶  
The table below shows a sample output of the transport model comprising the node, the wider nodal marginal km (observed on non-local assets) of an injection at the node with a consequent withdrawal at the reference node, the generation sited at the node, scaled to ensure total national generation equals total national demand.¶  
¶  
Genzone [327]
- Formatted [328]
- Formatted: Font: 11 pt, Bold, Underline
- Formatted: Font: 11 pt, Not Bold, No underline
- Formatted: Font: Not Bold
- Formatted: Font: Not Bold
- Formatted [329]
- Formatted: Font: 11 pt, English (U.K.)
- Formatted: English (U.K.)
- Deleted: 14.23 Example: Calculation of Zonal [330]
- Formatted: Left, Indent: Left: 0 cm
- Formatted: Left, Indent: Left: 0 cm
- Formatted: Left, Indent: Left: 0 cm
- Formatted: Font: 11 pt
- Formatted: English (U.K.)
- Formatted: Font: 11 pt
- Formatted: Font: 11 pt
- Formatted: Font: 11 pt
- Formatted: English (U.K.)
- Formatted: Font: 11 pt
- Formatted: Check spelling and grammar
- Formatted: Font: Arial, Font color: Dark Blue
- Formatted: Left, Indent: Left: 0 cm
- Formatted: Left, Indent: Left: 0 cm

## 14.25 Reconciliation of Demand Related Transmission Network Use of System Charges

Deleted: 4

This appendix illustrates the methodology used by The Company in the reconciliation of Transmission Network Use of System charges for demand. The example highlights the different stages of the calculations from the monthly invoiced amounts, right through to Final Reconciliation.

### Monthly Charges

Suppliers provide half-hourly (HH) and non-half-hourly (NHH) demand forecasts by BM Unit every quarter. An example of such forecasts and the corresponding monthly invoiced amounts, based on tariffs of £10.00/kW and 1.20p/kWh, is as follows:

	Forecast HH Triad Demand $HHD_F(kW)$	HH Monthly Invoiced Amount (£)	Forecast NHH Energy Consumption $NHHC_F(kWh)$	NHH Monthly Invoiced Amount (£)	Net Monthly Invoiced Amount (£)
Apr	12,000	10,000	15,000,000	15,000	25,000
May	12,000	10,000	15,000,000	15,000	25,000
Jun	12,000	10,000	15,000,000	15,000	25,000
Jul	12,000	10,000	18,000,000	19,000	29,000
Aug	12,000	10,000	18,000,000	19,000	29,000
Sep	12,000	10,000	18,000,000	19,000	29,000
Oct	12,000	10,000	18,000,000	19,000	29,000
Nov	12,000	10,000	18,000,000	19,000	29,000
Dec	12,000	10,000	18,000,000	19,000	29,000
Jan	7,200	(6,000)	18,000,000	19,000	13,000
Feb	7,200	(6,000)	18,000,000	19,000	13,000
Mar	7,200	(6,000)	18,000,000	19,000	13,000
Total		72,000		216,000	288,000

As shown, for the first nine months the Supplier provided a 12,000kW HH triad demand forecast, and hence paid HH monthly charges of £10,000  $((12,000kW \times £10.00/kW)/12)$  for that BM Unit. In January the Supplier provided a revised forecast of 7,200kW, implying a forecast annual charge reduced to £72,000  $(7,200kW \times £10.00/kW)$ . The Supplier had already paid £90,000, so the excess of £18,000 was credited back to the supplier in three £6,000 instalments over the last three months of the year.

The Supplier also initially provided a 15,000,000kWh NHH energy consumption forecast, and hence paid NHH monthly charges of £15,000  $((15,000,000kWh \times 1.2p/kWh)/12)$  for that BM Unit. In July the Supplier provided a revised forecast of 18,000,000kWh, implying a forecast annual charge increased to £216,000  $(18,000,000kWh \times 1.2p/kWh)$ . The Supplier had already paid £45,000, so the remaining £171,000 was split into payments of £19,000 for the last nine months of the year.

The right hand column shows the net monthly charges for the BM Unit.



### Initial Reconciliation (Part 1)

The Supplier's outturn HH triad demand, based on initial settlement data (and therefore subject to change in subsequent settlement runs), was 9,000kW. The HH triad demand reconciliation charge is therefore calculated as follows:

$$\text{HHD Reconciliation Charge} = (\text{HHD}_A - \text{HHD}_F) \times \text{£/kW Tariff}$$

$$= (9,000\text{kW} - 7,200\text{kW}) \times \text{£}10.00/\text{kW}$$

$$= 1,800\text{kW} \times \text{£}10.00/\text{kW}$$

$$= \text{£}18,000$$

**Formatted:** Font: Not Bold, Font color: Auto

**Formatted:** English (U.K.)

**Formatted:** Font: Not Bold, Font color: Auto

**Formatted:** English (U.K.)

To calculate monthly interest charges, the outturn HHD charge is split equally over the 12-month period. The monthly reconciliation amount is the monthly outturn HHD charge less the HH monthly invoiced amount. Interest payments are calculated based on these monthly reconciliation amounts using Barclays Base Rate.

Please note that payments made to BM Units with a net export over the Triad, based on initial settlement data, will also be reconciled at this stage.

As monthly payments will not be made on the basis of a negative forecast, the HHD Reconciliation Charge for an exporting BM Unit will represent the full actual payment owed to that BM Unit (subject to adjustment by subsequent settlement runs). Interest will be calculated as described above.

### Initial Reconciliation (Part 2)

The Supplier's outturn NHH energy consumption, based on initial settlement data, was 17,000,000kWh. The NHH energy consumption reconciliation charge is therefore calculated as follows:

$$\text{NHH Reconciliation Charge} = \frac{(\text{NHH}_A - \text{NHH}_F)}{100} \times \text{p/kWh Tariff}$$

$$= \frac{(17,000,000\text{kWh} - 18,000,000\text{kWh}) \times 1.20\text{p/kWh}}{100}$$

$$= \frac{-1,000,000\text{kWh} \times 1.20\text{p/kWh}}{100}$$

$$= \text{-£}12,000$$

**Formatted:** Font: Not Bold, Font color: Auto

**Formatted:** Font: Not Bold, Font color: Auto

**Formatted:** Font: Not Bold, Font color: Auto

[worked example 4.xls - Initial!J104](#)

The monthly reconciliation amount is equal to the outturn energy consumption charge for that month less the NHH monthly invoiced amount. Interest payments are calculated based on the monthly reconciliation amounts using Barclays Base Rate.

The net initial TNUoS demand reconciliation charge is therefore £6,000 (£18,000 - £12,000).

### Final Reconciliation

Finally, let us now suppose that after all final Settlement data has been received (up to 14 months after the relevant dates), the outturn HH triad demand and NHH energy consumption values were 9,500kW and 16,500,000kWh, respectively.

$$\begin{aligned} \text{Final HH Reconciliation Charge} &= (9,500\text{kW} - 9,000\text{kW}) \times \text{£}10.00/\text{kW} \\ &= \text{£}5,000 \end{aligned}$$

$$\begin{aligned} \text{Final NHH Reconciliation Charge} &= \frac{(16,700,000\text{kWh} - 17,000,000\text{kWh}) \times 1.20\text{p}/\text{kWh}}{100} \\ &= -\text{£}3,600 \end{aligned}$$

Consequently, the net final TNUoS demand reconciliation charge will be £1,400.

Interest payments are calculated based on the monthly reconciliation amounts using Barclays Base Rate.

Outturn data for BM Units with a net export over the Triad will be received at this stage and final reconciliation will be carried out, as required. Interest will be calculated as described above.

### Terminology:

**HHD<sub>A</sub>** = The Supplier's outturn half-hourly metered Triad Demand (kW) for the demand zone concerned.

**HHD<sub>F</sub>** = The Supplier's forecast half-hourly metered Triad Demand (kW) for the demand zone concerned.

**NHHC<sub>A</sub>** = The Supplier's outturn non-half-hourly metered daily Energy Consumption (kWh) for the period 16:00 hrs to 19:00 hrs inclusive (i.e. settlement periods 33 to 38) from April 1<sup>st</sup> to March 31<sup>st</sup>, for the demand zone concerned.

**NHHC<sub>F</sub>** = The Supplier's forecast non-half-hourly metered daily Energy Consumption (kWh) for the period 16:00 hrs to 19:00 hrs inclusive (i.e. settlement periods 33 to 38) from April 1<sup>st</sup> to March 31<sup>st</sup>, for the demand zone concerned.

**£/kW Tariff** = The £/kW Demand Tariff as shown in Schedule 1 of **The Statement of Use of System Charges** for the demand zone concerned.

**p/kWh Tariff** = The Energy Consumption Tariff shown in Schedule 1 of **The Statement of Use of System Charges** for the demand zone concerned.

## 14.26 Classification of parties for charging purposes

Deleted: 5

In the event of any conflict between this Appendix and the main text within this Statement, the main text within the Statement shall take precedence.

In the following diagrams, the parties liable for Transmission Network Use of System charges are outlined in red.

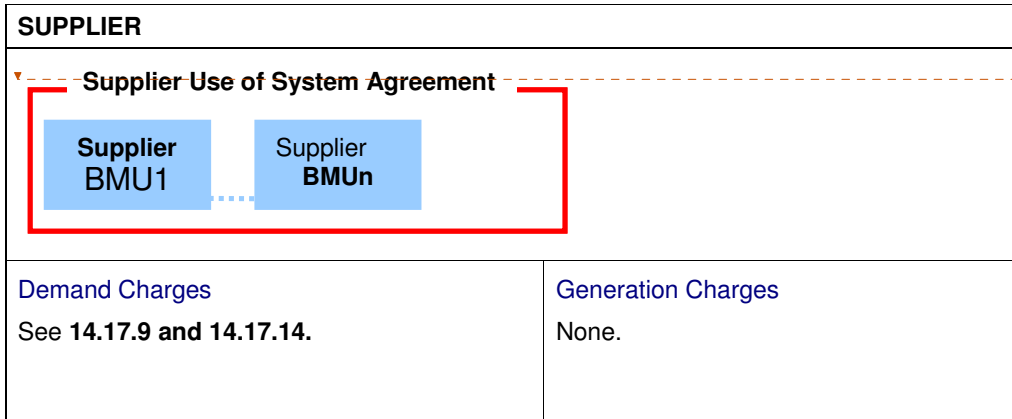

Deleted: 5

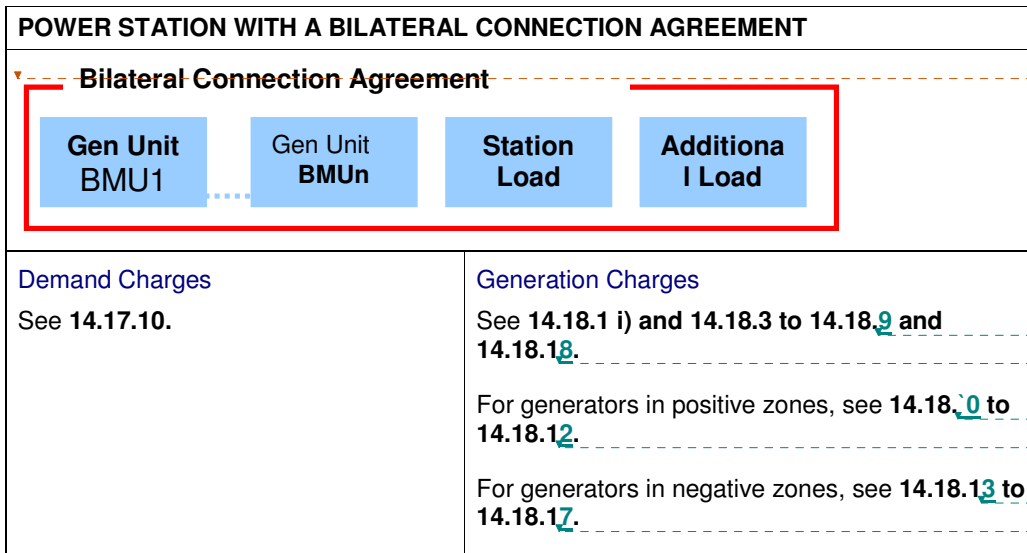

Deleted: 5

Deleted: 5

Deleted: 8

Deleted: 7

Deleted: 9

Deleted: 1

Deleted: 2

Deleted: 6

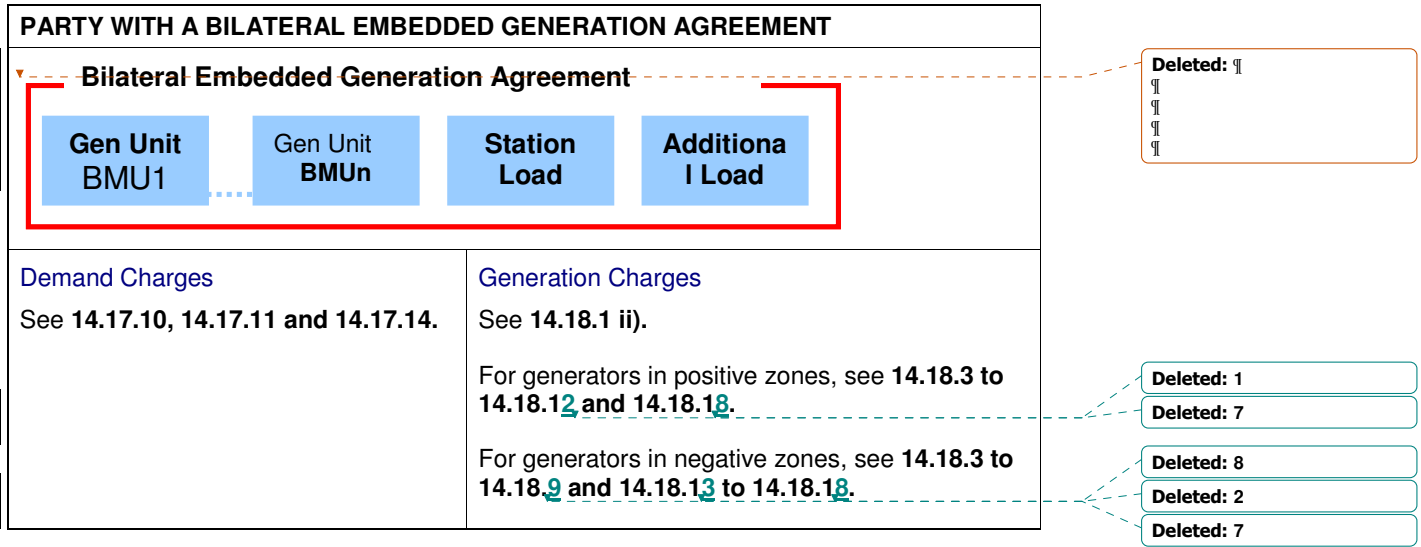

## 14.27 Transmission Network Use of System Charging Flowcharts

Deleted: 6

The following flowcharts illustrate the parties liable for Demand and Generation TNUoS charges and the calculation of those charges.

In the event of any conflict between this Appendix and the main text within this Statement, the main text within the Statement shall take precedence.

### Demand Charges

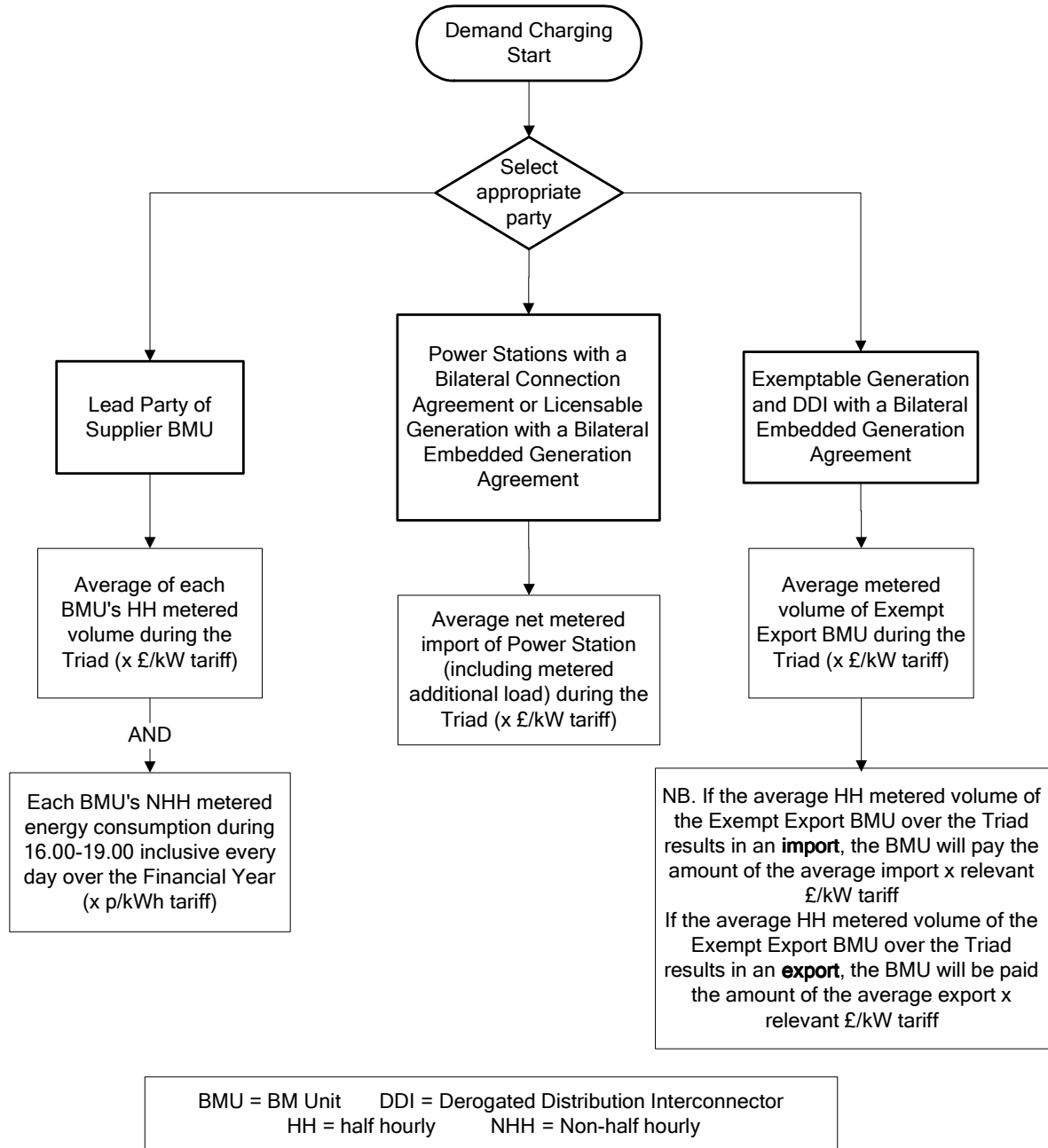

Generation Charges

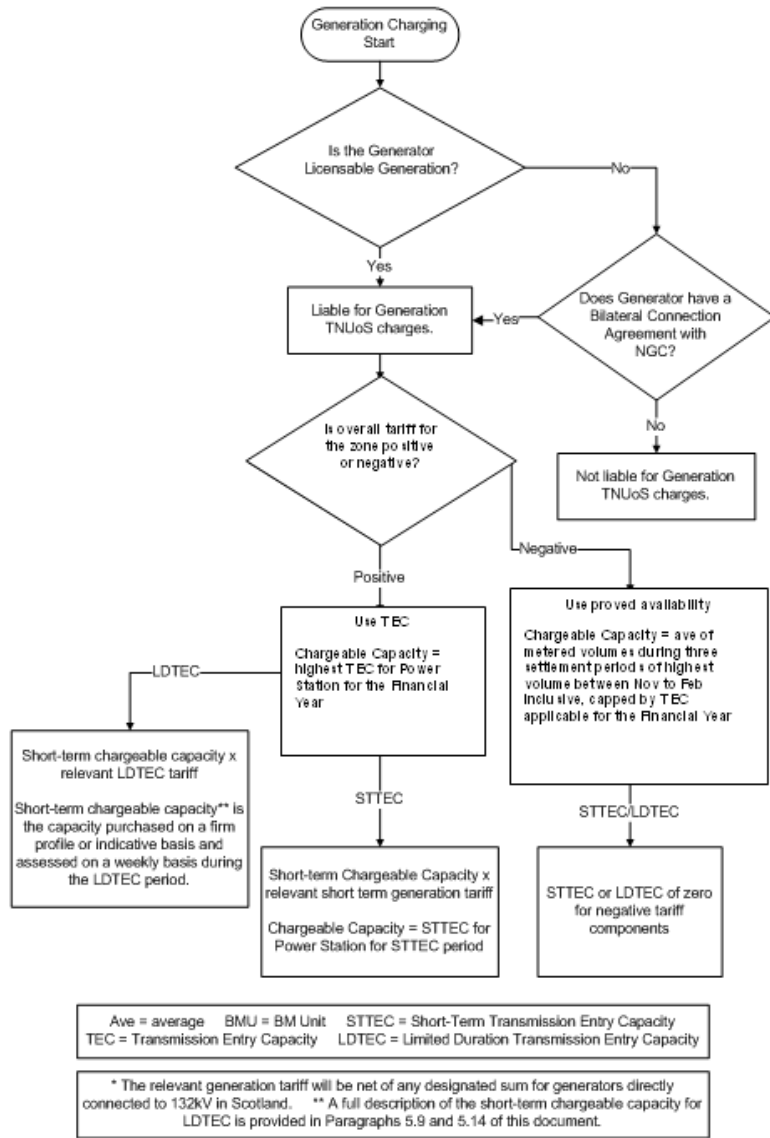

Short-term chargeable capacity x relevant LDTEC tariff

Short-term chargeable capacity\*\* is the capacity purchased on a firm profile or indicative basis and assessed on a weekly basis during the LDTEC period.

Ave TEC = T

\* Th connect

Deleted:

## 14.28 Example: Determination of The Company's Forecast for Demand Charge Purposes

Deleted: 7

The Company will use the latest available settlement data for calculation of HH demand and NHH energy consumption forecasts for the Financial Year.

The Financial Year runs from 1<sup>st</sup> April to 31<sup>st</sup> March inclusive and for the purpose of these examples the year April 2005 to March 2006 is used.

Where the preceding year's settlement data is not available at the time that The Company needs to calculate its forecast, The Company will use settlement data from the corresponding period in Financial Year minus two unless indicated otherwise.

All values used with the examples are purely for illustrative purposes only.

### i) Half-Hourly (HH) Metered Demand Forecast – Existing User

At the time of calculation of a HH demand forecast before the relevant Financial Year (approximately 10<sup>th</sup> March), The Company will be aware at a system level which dates will be used for the determination of Triad. However, The Company may not have settlement data at a User level if the Triad dates were to span a period that includes the latter half of February.

When undertaking forecasting before the relevant Financial Year, The Company will use the User's Triad demand for the previous year for its forecast providing it holds User settlement data for this period, thus:

$$F = T$$

where:

F = Forecast of User's HH demand at Triad for the Financial Year

T = User's HH demand at Triad in Financial Year minus one

Where The Company determines its forecast within a Financial Year:

$$F = T * D/P$$

where:

F = Forecast of User's HH demand at Triad for the Financial Year

T = User's HH demand at Triad in the preceding Financial Year

D = User's average half hourly metered demand in settlement period 35 in the Financial Year to date

P = User's average half hourly metered demand in settlement period 35 for the period corresponding to D in the preceding Financial Year

Where The Company determines its forecast before the relevant Financial Year and User settlement data for the Triad period is not available, The Company shall apply the formula immediately above (within year forecast) but substitute the following definitions for the values T, D, and P:

T = User's HH demand at Triad in the Financial Year minus two

D = User's average half hourly metered demand in settlement period 35 in the Financial Year minus one, to date

P = User's average half hourly metered demand in settlement period 35 for the period corresponding to D in the Financial Year minus two

**Example** (where User settlement data is not yet available for the Triad period):

The Company calculates a HH demand forecast on the above methodology at 10<sup>th</sup> March 2005 for the period 1<sup>st</sup> April 2005 to 31<sup>st</sup> March 2006.

$$F = 10,000 * 13,200 / 12,000$$

$$F = 11,000 \text{ kWh}$$

where:

T = 10,000 kWh (period November 2003 to February 2004)

D = 13,200 kWh (period 1<sup>st</sup> April 2004 to 15<sup>th</sup> February 2005#)

P = 12,000 kWh (period 1<sup>st</sup> April 2003 to 15<sup>th</sup> February 2004)

# Latest date for which settlement data is available.

**ii) Non Half-Hourly (NHH) Metered Energy Consumption Forecast – Existing User**

$$F = E * D/P$$

where:

F = Forecast of User's NHH metered energy consumption for the Financial Year

E = User's summed NHH energy consumption over the hours 16:00 to 19:00 for each day in the preceding Financial Year

D = User's summed NHH energy consumption for the hours 16:00 to 19:00 for each day for the Financial Year to date

P = User's summed NHH energy consumption for the hours 16:00 to 19:00 for each day for the period corresponding to D in the preceding Financial Year

**Example:**

The Company calculates a NHH energy consumption forecast on the above methodology at 10<sup>th</sup> June 2005 for the period 1<sup>st</sup> April 2005 to 31<sup>st</sup> March 2006.

$$F = 50,000,000 * 4,400,000 / 4,000,000$$

$$F = 55,000,000 \text{ kWh}$$

where:

E = 50,000,000 kWh (period 1<sup>st</sup> April 2004 to 31<sup>st</sup> March 2005)



D = 4,400,000 kWh (period 1<sup>st</sup> April 2005 to 15<sup>th</sup> May 2005#)

P = 4,000,000 kWh (period 1<sup>st</sup> April 2004 to 15<sup>th</sup> May 2004)

# Latest date for which settlement data is available

Where forecasting before the relevant Financial Year concerned, The Company would in the above example use values for E and P from Financial Year 2003/04 and D from Financial Year 2004/05.

**iii) Half-Hourly (HH) Metered Demand Forecast – New User**

F = M \* T/W

where:

F = Forecast of User's HH metered demand at Triad for the Financial Year

M = User's HH average weekday period 35 demand for the last complete month for which settlement data is available

T = Total system HH demand at Triad in the preceding Financial Year

W = Total system HH average weekday settlement period 35 metered demand for the corresponding period to M for the preceding year

**Example:**

The Company calculates a HH demand forecast on the above methodology at 10<sup>th</sup> September 2005 for a new User registered from 10<sup>th</sup> June 2005 for the period 10<sup>th</sup> June 2004 to 31<sup>st</sup> March 2006.

F = 1,000 \* 17,000,000 / 18,888,888

F = 900 kWh

where:

M = 1,000 kWh (period 1<sup>st</sup> July 2005 to 31<sup>st</sup> July 2005)

T = 17,000,000 kWh (period November 2004 to February 2005)

W = 18,888,888 kWh (period 1<sup>st</sup> July 2004 to 31<sup>st</sup> July 2004)

**iv) Non Half Hourly (NHH) Metered Energy Consumption Forecast – New User**

F = J + (M \* R/W)

where:

- F = Forecast of User's NHH metered energy consumption for the Financial Year
- J = Residual part month summed NHH metered energy consumption for the hours 16:00 to 19:00 for each day where new User registration takes place other than on the first of a month
- M = User's summed NHH metered energy consumption for the hours 16:00 to 19:00 for each day for the last complete month for which settlement data is available
- R = Total system summed NHH metered energy consumption for the hours 16:00 to 19:00 for each day for the period from the start of that defined under M but for the preceding year and until the end of that preceding Financial Year
- W = Total system summed NHH metered energy consumption for the hours 16:00 to 19:00 for each day for the period identified in M but for the preceding Financial Year

**Example:**

The Company calculates a NHH energy consumption forecast on the above methodology at 10<sup>th</sup> September 2005 for a new User registered from 10<sup>th</sup> June 2005 for the period 10<sup>th</sup> June 2005 to 31<sup>st</sup> March 2006.

$$F = 500 + (1,000 * 20,000,000,000 / 2,000,000,000)$$

$$F = 10,500 \text{ kWh}$$

where:

$$J = 500 \text{ kWh (period 10}^{\text{th}} \text{ June 2005 to 30}^{\text{th}} \text{ June 2005)}$$

$$M = 1,000 \text{ kWh (period 1}^{\text{st}} \text{ July 2005 to 31}^{\text{st}} \text{ July 2005)}$$

$$R = 20,000,000,000 \text{ kWh (period 1}^{\text{st}} \text{ July 2004 to 31}^{\text{st}} \text{ March 2005)}$$

$$W = 2,000,000,000 \text{ kWh (period 1}^{\text{st}} \text{ July 2004 to 31}^{\text{st}} \text{ July 2004)}$$

## 14.29 Stability & Predictability of TNUoS tariffs

Deleted: 8

### Stability of tariffs

The Transmission Network Use of System Charging Methodology has a number of elements to enhance the stability of the tariffs, which is an important aspect of facilitating competition in the generation and supply of electricity. This appendix seeks to highlight those elements.

Each node of the transmission network is assigned to a zone. The result of this is to dampen fluctuations that would otherwise be observed at a given node caused by changes in generation, demand, and network parameters. The criteria used to establish generation zones are part of the methodology and are described in Paragraph 14.15.32.

Deleted: 26

These zones are themselves fixed for the duration of the price control period. The methodology does, however, allow these to be revisited in exceptional circumstances to ensure that the charges remain reasonably cost reflective or to accommodate changes to the network. In rare circumstances where such a re-zoning exercise is required, this will be undertaken in such a way that minimises the adverse impact on Users. This is described in Paragraph 14.15.35.

Deleted: 29

In addition to fixing zones, other key parameters within the methodology are also fixed for the duration of the price control period or annual changes restricted in some way. Specifically:

- the expansion constant, which reflects the annuitised value of capital investment required to transport 1MW over 1km by a 400kV over-head line, changes annually according to RPI. The other elements used to derive the expansion constant are only reviewed at the beginning of a price control period to ensure that it remains cost-reflective. This review will consider those components outlined in Paragraph 14.15.48 to Paragraph 14.15.58.
- the expansion factors, which are set on the same basis of the expansion constant and used to reflect the relative investment costs in each TO region of circuits at different transmission voltages and types, are fixed for the duration price control. These factors are reviewed at the beginning of a price control period and will take account of the same factors considered in the review of the expansion constant.
- the locational security factor, which reflects the transmission security provided under the NETS Security and Quality of Supply Standard, is fixed for the duration of the price control period and reviewed at the beginning of a price control period.

Deleted: 31

Deleted: 41

### Predictability of tariffs

The Company revises TNUoS tariffs each year to ensure that these remain cost-reflective and take into account changes to allowable income under the price control and RPI. There are a number of provisions within The Company's Transmission Licence and the CUSC designed to promote the predictability of annually varying charges. Specifically, The Company is required to give the Authority 150 days notice of its intention to change use of system charges together with a reasonable assessment of the proposals on those charges; and to give Users 2 months written notice of any revised charges. The Company typically provides an additional months notice of revised charges through the publication of "indicative" tariffs. Shorter notice periods are permitted by the framework but only following consent from the Authority.

These features require formal proposals to change the Transmission Use of System Charging Methodology to be initiated in October to provide sufficient time for a formal consultation and the Authority's veto period before charges are indicated to Users.

More fundamentally, The Company also provides Users with the tool used by The Company to calculate tariffs. This allows Users to make their own predictions on how future changes in the generation and supply sectors will influence tariffs. Along with the price control information, the data from the Seven Year Statement, and Users own prediction of market activity, Users are able to make a reasonable estimate of future tariffs and perform sensitivity analysis.

To supplement this, The Company also prepares an annual information paper that provides an indication of the future path of the locational element of tariffs over the next five years.<sup>4</sup> This analysis is based on data included within the Seven Year Statement. This report typically includes:

- an explanation of the events that have caused tariffs to change;
- sensitivity analysis to indicate how generation and demand tariffs would change as a result of changes in generation and demand at certain points on the network that are not included within the SYS;
- an assessment of the compliance with the zoning criteria throughout the five year period to indicate how generation zones might need to change in the future, with a view to minimising such changes and giving as much notice of the need, or potential need, to change generation zones; and
- a complete dataset for the DCLF Transport Model developed for each future year, to allow Users to undertake their own sensitivity analysis for specific scenarios that they may wish to model.

The first year of tariffs forecasted in the annual information paper are updated twice throughout the proceeding financial year as the various Transport and Tariff model inputs are received or amended. These updates are in addition to the Authority 150 days notice and publication of “indicative” tariffs.

| In addition, The Company will, when revising generation charging zones prior to a new price control period, undertake a zoning consultation that uses data from the latest information paper. The purpose of this consultation will be to ensure tariff zones are robust to contracted changes in generation and supply, which could be expected to reduce the need for re-zoning exercises within a price control period.

**Formatted:** Justified

**Deleted:** ¶  
¶  
¶  
-----Page Break-----  
¶

<sup>4</sup> <http://www.nationalgrid.com/uk/Electricity/Charges/gbchargingapprovalconditions/5/>



## Annual Load Factor (ALF)

14.15.76 The ALF for each individual Power Station is calculated using the relevant TEC (MW) and corresponding output data. Where output data is not available for a Power Station, including for new Power Stations and emerging Power Station technologies, generic data for the appropriate generation plant type will be used.

14.15.77 For a given charging year “t” the Power Station ALF will be calculated based on the average of the previous five charging years for renewable generation and the average of previous two years for non-renewable generation (for the avoidance of doubt, biomass generation will be considered as non-renewable generation for the calculation of ALF) generation. The ALF is calculated for each charging year as set out below.

$$ALF = \frac{\sum_{p=1}^{17520} GMWh_p}{\sum_{p=1}^{17520} TEC_p \times 0.5}$$

Where:

GMWh<sub>p</sub> is the maximum of FPN or actual metered output in a Settlement Period related to the Power Station TEC (MW); and

TEC<sub>p</sub> is the TEC (MW) applicable to that Power Station for that Settlement Period including any STTEC and LDTE C. accounting for any trading of TEC.

14.15.78 The appropriate output (FPN or actual metered) figure is derived from BM Unit data available to the Company and relates to the total TEC of the Power Station.

14.15.79 Each Power Station will receive draft ALFs by 31<sup>st</sup> October of the charging year (t-1) for the charging year (t) and will have a period of 30 days to either query or submit their own user forecast where they anticipate their ALF in the next charging year (t) will be materially different from the Company’s figure. The Company will use this forecast provided by the Power Station in calculating TNUoS tariffs to apply in the next charging year (t).. Failure to agree changes relating to errors will be treated as a charging dispute under the CUSC.

14.15.80 The ALFs used in the setting of final tariffs will be published in the annual Statement of Use of System Charges. Changes to ALFs after this publication will not result in changes to published tariffs (e.g. following dispute resolution).

14.15.81 Where a User has provided their own user forecast for their ALF, the Company reserves the right to query the basis of this forecast.

14.15.82 At the end of the charging year (t), the Company will calculate the actual Annual Load Factors for each individual Power Station connected to the transmission system by 31<sup>st</sup> May (t+1), which would then be compared to the Power Station’s forecast (where submitted).

14.15.83 Where the difference between the Power Station's actual and forecast ALF is less than 2% (tolerance band) no further action will be taken by the Company. Where the actual ALF exceeds the Power Station's forecast ALF by more than 2%, the excess above 2% will be charged at 1.5 times that Power Station's applicable TNUoS charge in the charging year (t).

14.15.84 Reconciliation payments will be due for payment, by the Power Station, 30 Working Days after the date of invoice by the Company. Any additional TNUoS revenue received from generators' reconciliation payments will effectively be an over-recovery from one charging year (t) arising in the next charging year (t+1). Any TNUoS over-recovery value will be returned to generators in proportion to their TEC (MW) value in the preceding charging year's (t) charging model (i.e. on the same basis as the residual element of the TNUoS charge) within 90 Working Days of the end of the charging year (t).

14.15.85 Due to the aggregation of output (FPN or actual metered) data for dispersed generation (e.g. cascade hydro schemes), where a single generator BMU consists of geographically separated power stations, the ALF would be calculated based on the total output of the BMU and the overall TEC (MW) of those Power Stations .

14.15.86 In the event that the required number of full charging years of an individual Power Station's output is not available, missing output (FPN or actual metered) data would be replaced by generic data for that generation plant type to ensure the required number of charging years of information are available for the Power Station. The derivation of the generic data is described in paragraphs 14.15.85-14.15.88.

Deleted: 82  
Deleted: 85

14.15.87 All Power Station ALFs are published in the Statement of Use of System Charges. This includes user those submitted as user forecasts.

### Derivation of Generic ALFs

14.15.88 The generic ALF is derived from the average annual output of the ten most recently commissioned GB generation of a particular generation plant type that have at least five charging years' data, using an identical methodology to that used for the Power Station specific calculation described above. Where less than ten GB generators of a particular generation plant type exist, then data from all existing generators of that particular generation plant type will be used. Example generation plant type categories are listed below;

Fuel Type
Biomass
Coal
Gas
Hydro
Nuclear (by reactor type)
Oil & OCGTs
Pumped Storage
Onshore Wind
Offshore Wind
CHP

14.15.89 The Company will keep these categories under review and update as necessary. Where within a category there is a significant locational difference consideration will be given to zonal generic factors. The factors used will be published in the Statement of Use of System Charges and will be reviewed annually.

14.15.90 If a User can demonstrate that the generation plant type of a Power Station has changed, consideration will be given to the use of relevant generic ALF information in the calculation of their charges until sufficient specific data is available.

14.15.91 For new and emerging generation plant types, where insufficient data is available to allow a generic ALF to be developed, The Company will use the best information available; e.g. from manufacturers and data from use of similar technologies outside GB. The factor will be agreed with the relevant User. In the event of a disagreement the standard provisions for dispute in the CUSC will apply.

## 14.19 Data Requirements

### Data Required for Charge Setting

14.19.1 Users who are Generators or Interconnector Asset Owners provide to The Company a forecast for the following Financial Year of the highest Transmission Entry Capacity (TEC) applicable to each Power Station or Interconnector for that Financial Year. For Financial Year 2008/9 Scottish Generators or Interconnector Asset Owners provide to The Company a forecast of the equivalent highest 'export' capacity figure. This data is required by The Company as the basis for setting TNUoS tariffs. The Company may request these forecasts in the November prior to the Financial Year to which they relate, in accordance with the CUSC. Additionally users who are Generators provide to The Company details of their generation plant type, and are able to submit a forecast of their annual load factor where they believe it will differ materially from the forecast provided by the Company..





## Islands and HVDC Alternative Legal Text for Section 14.15.57

**100% option (i.e. for Original and WACMs 1- 6)** – following paragraph is included in Section 14.15.57 –

14.15.57 For HVDC transmission circuit expansion factors both the full cost of the converter stations and the full cost of the cable are included in the calculation.

**50%/50% option (i.e. for WACMs 28, 30 – 33)** - replace paragraph 14.15.57 in Section 14 by the following paragraph -

14.15.57 HVDC transmission circuit expansion factors include the full cost of the cable but only 50% of the cost of the converter stations.

**30%/40% option (i.e. for WACMs 7, 9 and 12)** – replace paragraph 14.15.57 in Section 14 by the following paragraph –

14.15.57 HVDC transmission circuit expansion factors for circuits with Current Source Converters (CSC) include the full cost of the cable but only 40% of the cost of the converter stations in the calculation. HVDC circuit expansion factors for transmission circuits with Voltage Source Converters (VSC) include the full cost of the cable but only 30% of the cost of the converter stations in the calculation.

**40%/50% option (i.e. for WACMs 14, 16 - 19)** – replace paragraph 14.15.57 in Section 14 by the following paragraph –

14.15.57 HVDC transmission circuit expansion factors for circuits with Current Source Converters (CSC) include the full cost of the cable but only 40% of the cost of the converter stations in the calculation. HVDC transmission circuit expansion factors for circuits with Voltage Source Converters (VSC) include the full cost of the cable but only 50% of the cost of the converter stations in the calculation.

**50%/30% option (i.e. for WACM 40)** – replace paragraph 14.15.57 in Section 14 by the following paragraph –

14.15.57 HVDC transmission circuit expansion factors for circuits with Current Source Converters (CSC) include the full cost of the cable but only 50% of the cost of the converter stations in the calculation. HVDC transmission circuit expansion factors for circuits with Voltage Source Converters (VSC) include the full cost of the cable but only 30% of the cost of the converter stations in the calculation.

**Specific option (i.e. for WACMs 21 – 26)** - replace paragraph 14.15.57 in Section 14 by the following paragraph –

14.15.57 For calculating, HVDC transmission circuit expansion factors the full cost of the cable is included but a specific percentage reduction is removed from the cost of the converter stations as determined by The Company using reasonable endeavours on a case by case basis. This specific percentage reflects the converter station elements that have equivalent AC substation

characteristics. Where information is not available to The Company on a case by case basis then the HVDC transmission circuit expansion factors shall include the full cost of the cable and a percentage of the cost of the converter stations based on available default generic information.