

## Stage 05: Draft CUSC Modification Report

---

- Volume 2

Connection and Use of System Code (CUSC)

# CMP213 Project TransmiT TNUoS Developments

---

## Annexes

---

Published on: 14<sup>th</sup> May 2013

---

What stage is this document at?

01	Initial Written Assessment
02	Workgroup Consultation
03	Workgroup Report
04	Code Administrator Consultation
05	Draft CUSC Modification Report
06	Final CUSC Modification Report

## Contents

Annex 1 – Workgroup Terms of Reference .....	3
Annex 2 – CMP213 Proposal Form.....	9
Annex 3 – Workgroup Attendance Register .....	17
Annex 4 – Workgroup consultation - Sharing .....	18
Annex 5 – Workgroup consultation - HVDC .....	94
Annex 6 – Workgroup consultation - Islands .....	105
Annex 7 – Project TransmiT Background.....	124
Annex 8 – Detail of Original Proposal.....	132
Annex 9 – ALF vs. Annual Incremental Cost Analysis .....	143
Annex 10 – ALF and Changes to Plant Running Profiles.....	148
Annex 11 – Comparison of Tariff Volatility.....	153
Annex 12 – Annual Load Factor Under the Original .....	163
Annex 13 – Bath University report .....	168
Annex 14 – Papers presented to Workgroup in support of potential alternatives.....	199
Annex 15 – Impact assessment modelling results .....	230
Annex 16 – Results of the Workgroup vote on WACMs .....	266
Annex 17 – Illustrative TNUoS Charges for Island Developments ....	275



### Any Questions?

Contact:

**Adelle McGill**

Code Administrator



[adelle.mcgill@nationalgrid.com](mailto:adelle.mcgill@nationalgrid.com)



01926 653142

Proposer:

**Ivo Spreeuwenberg**

Company

**National Grid**

## About this document

This document contains the annexes to the Draft CUSC Modification Report for CMP213.

## Document Control

Version	Date	Author	Change Reference
1.0	14 May 2013	Code Administrator	Publication to Industry

### Workgroup Terms of Reference and Membership

#### TERMS OF REFERENCE FOR CMP213 WORKGROUP

#### Responsibilities

1. The Workgroup is responsible for assisting the CUSC Modifications Panel in the evaluation of CUSC Modification Proposal CMP213 "Project TransmiT TNUoS Developments", tabled by National Grid Electricity Transmission plc at the CUSC Modifications Panel meeting on 29 June 2012.
2. The proposal must be evaluated to consider whether it better facilitates achievement of the Applicable CUSC Objectives. These can be summarised as follows:

#### Use of System Charging Methodology

- (a) that compliance with the use of system charging methodology facilitates effective competition in the generation and supply of electricity and (so far as is consistent therewith) facilitates competition in the sale, distribution and purchase of electricity;
  - (b) that compliance with the use of system charging methodology results in charges which reflect, as far as is reasonably practicable, the costs (excluding any payments between transmission licensees which are made under and in accordance with the STC) incurred by transmission licensees in their transmission businesses and which are compatible with standard condition C26 (Requirements of a connect and manage connection);
  - (c) that, so far as is consistent with sub-paragraphs (a) and (b), the use of system charging methodology, as far as is reasonably practicable, properly takes account of the developments in transmission licensees' transmission businesses.
3. It should be noted that additional provisions apply where it is proposed to modify the CUSC Modification provisions, and generally reference should be made to the Transmission Licence for the full definition of the term.

#### Scope of work

4. The Workgroup must consider the issues raised by the Modification Proposal and consider if the proposal identified better facilitates achievement of the Applicable CUSC Objectives.

5. In addition to the overriding requirement of paragraph 4, the Workgroup shall consider and report on the following specific issues:

### **Network Capacity Sharing**

- a) whether intermittent generation should contribute to the peak element of the tariff
- b) whether load factor is an appropriate measure of the level of sharing
- c) whether the proposed method for calculating load factor is an appropriate measure of forward looking charges (subject to item b)
- d) whether to use maximum line flow when attributing circuit MWkm to the Peak and Year Round elements or an alternative approach
- e) whether shortening circuit MWkm may be an alternative to the use of load factor in reflecting sharing
- f) compare modelled charging outputs to real network investment costs

### **HVDC**

- g) how often the parameters associated with the proposed approach should be updated (e.g. annually, every 4 years, every 8 years)

### **Island Links**

- h) ensure that the charging solution is commensurate with access rights
- i) consider appropriate approach for islands that form part of integrated offshore networks
- j) review the application of the expansion factor in the tariff calculation

### **General**

- k) consider and undertake appropriate economic analysis including the Impact on current and future consumers on a national and regional basis
  - l) consider and undertake appropriate environmental analysis and review illustrative legal text including an assessment of likely impact on electricity generation carbon intensity
6. The Workgroup is responsible for the formulation and evaluation of any Workgroup Alternative CUSC Modifications (WACMs) arising from Group discussions which would, as compared with the Modification Proposal or the current version of the CUSC, better facilitate achieving the Applicable CUSC Objectives in relation to the issue or defect identified.
  7. The Workgroup should become conversant with the definition of Workgroup Alternative CUSC Modification which appears in Section 11 (Interpretation and Definitions) of the CUSC. The definition entitles the Group and/or an individual member of the Workgroup to put forward a WACM if the member(s) genuinely believes the WACM would better facilitate the achievement of the Applicable CUSC Objectives, as compared with the Modification Proposal or the current version of the CUSC. The extent of the support for the Modification Proposal or any WACM arising from the Workgroup's discussions should be clearly described in the final Workgroup Report to the CUSC Modifications Panel.



8. Workgroup members should be mindful of efficiency and propose the fewest number of WACMs possible.
9. All proposed WACMs should include the Proposer(s)'s details within the final Workgroup report, for the avoidance of doubt this includes WACMs which are proposed by the entire Workgroup or subset of members.
10. There is an obligation on the Workgroup to undertake a period of Consultation in accordance with CUSC 8.20. The Workgroup Consultation period shall be for a period of 4 weeks as determined by the Modifications Panel.
11. Following the Consultation period the Workgroup is required to consider all responses including any WG Consultation Alternative Requests. In undertaking an assessment of any WG Consultation Alternative Request, the Workgroup should consider whether it better facilitates the Applicable CUSC Objectives than the current version of the CUSC.

As appropriate, the Workgroup will be required to undertake any further analysis and update the original Modification Proposal and/or WACMs. All responses including any WG Consultation Alternative Requests shall be included within the final report including a summary of the Workgroup's deliberations and conclusions. The report should make it clear where and why the Workgroup chairman has exercised his right under the CUSC to progress a WG Consultation Alternative Request or a WACM against the majority views of Workgroup members. It should also be explicitly stated where, under these circumstances, the Workgroup chairman is employed by the same organisation who submitted the WG Consultation Alternative Request.

12. The Workgroup is to submit its final report to the Modifications Panel Secretary on 6 December 2012 for circulation to Panel Members. The final report conclusions will be presented to the CUSC Modifications Panel meeting on 14 December 2012.

## Membership

13. The Workgroup has the following members:

Role	Name	Representing
Chairman	Patrick Hynes	Code Administrator
National Grid Representative*	Ivo Spreeuwenberg	National Grid
Industry Representatives*	James Anderson	ScottishPower
	Garth Graham	SSE
	Simon Lord	First Hydro
	Stuart Cotten	Drax Power
	Paul Jones	E.ON UK
	Frank Prashad	RWE
	Michael Dodd	ESBI
	Stefan Leedham	EDF
	Dennis Gowland	The European Marine Energy Centre (EMEC) Ltd
	Ricky Hill	Centrica
	Helen Snodin	Scottish Renewables / Highlands and Islands

Role	Name	Representing
		Enterprise
	Maf Smith	RenewableUK
	Patrick Smart	RES
	Nick Fedorkiw	Mainstream Renewable Power
	Peter Waghorn	Phillips 66 / Immingham CHP LLP
Authority Representatives	Ebba John Anthony Mungall	DONG Energy Ofgem
Technical Secretary	Jackeline Crespo- Sandoval / Adelle McGill	Code Administrator
Observer	Nick Kay	Uisenis

NB: A Workgroup must comprise at least 5 members (who may be Panel Members). The roles identified with an asterisk in the table above contribute toward the required quorum, determined in accordance with paragraph 14 below.

14. The chairman of the Workgroup and the Modifications Panel Chairman must agree a number that will be quorum for each Workgroup meeting. The agreed figure for CMP213 is that at least 5 Workgroup members must participate in a meeting for quorum to be met.
15. A vote is to take place by all eligible Workgroup members on the Modification Proposal and each WACM. The vote shall be decided by simple majority of those present at the meeting at which the vote takes place (whether in person or by teleconference). The Workgroup chairman shall not have a vote, casting or otherwise. There may be up to three rounds of voting, as follows:
  - Vote 1: whether each proposal better facilitates the Applicable CUSC Objectives;
  - Vote 2: where one or more WACMs exist, whether each WACM better facilitates the Applicable CUSC Objectives than the original Modification Proposal;
  - Vote 3: which option is considered to BEST facilitate achievement of the Applicable CUSC Objectives. For the avoidance of doubt, this vote should include the existing CUSC baseline as an option.

The results from the vote and the reasons for such voting shall be recorded in the Workgroup report in as much detail as practicable.

16. It is expected that Workgroup members would only abstain from voting under limited circumstances, for example where a member feels that a proposal has been insufficiently developed. Where a member has such concerns, they should raise these with the Workgroup chairman at the earliest possible opportunity and certainly before the Workgroup vote takes place. Where abstention occurs, the reason should be recorded in the Workgroup report.
17. Workgroup members or their appointed alternate are required to attend a minimum of 50% of the Workgroup meetings to be eligible to participate in the Workgroup vote.

18. The Technical Secretary shall keep an Attendance Record for the Workgroup meetings and circulate the Attendance Record with the Action Notes after each meeting. This will be attached to the final Workgroup report.
19. The Workgroup membership can be amended from time to time by the CUSC Modifications Panel.

## Appendix: Indicative Workgroup Timetable

The following timetable is indicative for the CMP213 Workgroup (as at July 2012).

w/c 2 July	Send out request for WG nominations
10 July	First Workgroup meeting
July – September	Fortnightly Workgroup meetings
8 October	Issue draft Workgroup Consultation for Workgroup comment (5 working days)
15 October	Deadline for comments on draft Workgroup Consultation
17 October	Publish Workgroup consultation (for 4 weeks)
14 November	Deadline for responses to Workgroup consultation
w/c 19 November	Post-consultation Workgroup meeting
27 November	Circulate draft Workgroup Report
4 December	Deadline for comment on Workgroup report
6 December	Submit final Workgroup report to Panel Secretary
14 December	Present Workgroup report to CUSC Modifications Panel

<b>CUSC Modification Proposal Form (for Charging Methodology proposals)</b>	<b>CMP213</b>
<b>Title of the CUSC Modification Proposal:</b> <i>(mandatory by proposer)</i> Project TransmiT TNUoS Developments	
<b>Submission Date</b> <i>(mandatory by Proposer)</i> 20/06/2012	
<b>Description of the CUSC Modification Proposal:</b> <i>(mandatory by proposer)</i>  This modification proposal is submitted in order to fulfil the requirements of the direction to NGET by the Authority, arising from the TransmiT TNUoS SCR process. In line with that direction, there are three main elements making up this proposal: <ul style="list-style-type: none"> <li>(i) Recognition of network capacity sharing by generators in the Investment Cost Related Pricing (ICRP) TNUoS charge calculation;</li> <li>(ii) Introduction of an approach for including HVDC links that parallel the onshore AC network into the charging methodology;</li> <li>(iii) Introduction of an approach for including Island links in the charging methodology.</li> </ul> The specific proposals that follow are expected to facilitate and not preclude any further consideration of the relevant issues and / or development of different approaches that may better achieve the purposes and objectives of this proposal as required by the miscellaneous terms set out in the Authority's direction that this proposal should be developed so as to be consistent with the principles of cost reflectivity, whilst having regard to the desirability for stability and simplicity in transmission pricing, and as far as possible it should: <ul style="list-style-type: none"> <li>a) further the applicable relevant objectives,</li> <li>b) maximise value for money to existing and future consumers,</li> <li>c) be supported by a robust evidence base, and</li> <li>d) give due consideration to the interests of existing and future consumers in the achievement of sustainable development.</li> </ul> A detailed description of the aforementioned three main elements follows. <p><b>(i) Network Capacity Sharing</b></p> In addition to recovering allowed revenue, Transmission Network Use of System (TNUoS) charges reflect the cost of installing, operating and maintaining the transmission system for the Transmission Owner (TO) activity functions of each GB Transmission Licensee. These activities are undertaken to the standards prescribed by the Transmission Licences, to provide the capability to allow the flow of bulk transfers of power between connection sites over a year of operation and to provide transmission system security.           The underlying rationale behind TNUoS charges is that efficient economic signals are provided to Users when services are priced to reflect the incremental costs of supplying them. Therefore, charges should reflect the impact that users of the transmission system at different locations would have on the Transmission Owner's costs, if they were to increase or decrease their use of the respective systems. This rationale is currently accounted for using the Investment Cost Related Pricing (ICRP) methodology which considers the incremental effect of generation and demand via a DC load flow (DCLF) based "Transport" model. The derivation of the incremental investment costs at different points on the system is currently determined against the requirements of the system at the time of peak demand.           As a greater proportion of variable, renewable generation connects to the transmission network, the output of many conventional generators has also become more variable in nature. As generators of different types change the way in which they use the transmission network, the nature of transmission capacity investment planning has also altered to ensure efficient investment is undertaken. This is	

exemplified in the recent changes to the NETS SQSS (GSR-009) and the increasing amount of investment justified on the basis of avoided future constraint costs (i.e. outside of the deterministic NETS SQSS standards). However, the associated commercial arrangements have yet to fully evolve to reflect these underlying physical changes.

The industry began a process of reviewing the commercial framework to reflect the aforementioned changes through the Transmission Access Review (TAR) process from 2007 to 2010. Through this process, the possibility of explicitly recognising the differential impact on network costs by generators with different characteristics into charging and access arrangements was considered. However, this process culminated in the Secretary of State rejecting this explicit recognition in favour of a form of Connect and Manage. As a result, this modification proposal does not propose to alter the form of access rights afforded to generators (in the form of Transmission Entry Capacity - TEC) through the government's decision. Rather, it seeks to improve the cost-reflectivity of TNUoS tariffs for generators by implicitly recognising that this sharing takes place and is taken into account in an equally implicit manner in the network investment planning process.

This proposal seeks to recognise the implicit sharing of the wider transmission network (local circuits are not planned on the basis of being shared and are therefore not deemed to be shared) by altering the way in which the wider tariff is calculated within the Transport and Tariff model, thus improving its cost-reflectivity.

Transport Model

This proposal seeks to replace the existing peak background in the Transport model with two separate background conditions, representing peak security and year round conditions respectively. Whilst the existing DCLF in the Transport model sets up the peak demand background by scaling down the contracted TEC of all generators equally to meet total demand, the proposal would setup two peak demand conditions and scale generation differently under each to reflect the values used in the NETS SQSS. Some of these values would be fixed year on year and some would vary depending on the demand level in the year under consideration. The values that would have arisen from 2011/12 data are as follows:

<b>Generator Type</b>	<b>TEC</b>	<b>Current Methodology</b>	<b>Peak Security Background</b>	<b>Year Round Background</b>
Intermittent	5,460	65.5%	0%	70%
Nuclear & CCS	10,753	65.5%	72.5%	85%
Interconnectors	3,268	65.5%	0%	100%
Hydro	635	65.5%	72.5%	66%
Pumped Storage	2,744	65.5%	72.5%	50%
Peaking	5,025	65.5%	72.5%	0%
Other (Conventional)	61,185	65.5%	72.5%	66%
Values in grey vary depending on the total demand level, whilst values in black are fixed scaling factors corresponding to those used in the NETS SQSS				

In order to ascertain whether the incremental investment driver on a given circuit is related to peak security or year round conditions, the power flows on each circuit are compared and a proportion of the circuit is allocated to a given investment driver (i.e. peak security or year round). It is proposed that the allocation is done on the basis of whole circuits being either peak security or year round driven, with the background leading to the highest flows on a given circuit dictating its investment driver and allocation.

Once the allocation process is complete an incremental MW would be applied at each node in the DCLF model, as occurs in the existing methodology, in order to establish the effect of that additional MW on the transmission network as a whole. Under this proposal, the incremental MW process would occur at each node in turn for both the peak security and year round conditions. Ultimately, this process results in the incremental impact (i.e. MWkm) for each circuit under both conditions. These MWkm would subsequently be allocated to either the peak security or year round conditions, based on the aforementioned allocation of a given circuit to an investment driver. The splitting of MWkm across two background conditions, representative of different investment drivers, is the first in a two step process. A further step is required in order to make an improvement to the cost-reflectivity of this approach.

As transmission investment is no longer solely planned for peak security conditions the proposal recognises that the impact of an incremental MW on the need for network capacity varies depending on the type of generation, as well as its location. This proposal would scale the year round incremental MWkm of each individual generator depending on its impact on the transmission network, as detailed in the following paragraph. For the peak incremental MWkm it is proposed to maintain the existing uniform treatment of generation (i.e. treat all generation capacity the same regardless of plant type), with the exception that the incremental MWkm of intermittent plant is scaled to 0% in recognition of the assumptions made when planning network capacity. Where a different approach is developed through the working group process that is reasonably considered by the proposer to better meet the miscellaneous terms set out in the Authority's direction, it shall be substituted into this proposal in accordance with the proposer's rights under clauses 8.16.10 and 8.20.23 of the CUSC. It is recognised that stand-alone alternatives may also be developed through the working group process.

Explicit commercial arrangements are not in place that provide Transmission Licensees with information to assess the impact on the need for transmission network investment arising from an individual generator when planning investment. Therefore implicit assumptions over input prices (fuel, CO<sub>2</sub>, subsidy, etc.) and generator characteristics (efficiency, availability, etc.) relative to the remainder of the market are made. In order to remain cost-reflective, any proposed scaling factor needs to be reflective of the implicit assumptions made when planning network capacity. This proposal puts forward a form of generator specific annual load factor, based on 5 years historic output, as representative of the assumptions made when planning investment and achieving an appropriate balance between simplicity and cost-reflectivity. In order to maintain what is deemed to be an appropriate balance it is proposed that the annual load factor be applied in an equal manner across all wider TNUoS zones regardless of generation plant mix. Where a different approach is developed through the working group process that is reasonably considered by the proposer to better meet the miscellaneous terms set out in the Authority's direction, it shall be substituted into this proposal in accordance with the proposer's rights under clauses 8.16.10 and 8.20.23 of the CUSC. It is recognised that stand-alone alternatives may also be developed through the working group process.

#### Tariff Model

The Tariff model utilises the incremental MWkm and the unit cost of these MWkms (i.e. the expansion constant and expansion factors) in order to calculate the locational signal, which forms part of the wider TNUoS tariff. Once this is completed and the proportion of revenue collected from the locational element is known, the Tariff model also calculates the non-locational, residual element to ensure that the total allowed revenue is recovered in the proportion of 27% from generators and 73% from demand users of the network. Together the locational and residual elements of the tariff form the wider TNUoS tariff in the existing methodology.

Under this proposal the structure of the wider TNUoS tariff would change to mirror the changes in the Transport model, such that the locational element is split into a peak security element and a year round element. As a result the TNUoS charge for an individual generator arising from the wider element of the TNUoS tariff would be calculated as follows:

$$(\text{Peak Security } \text{£/kW} + \text{Year Round } \text{£/kW} + \text{Residual } \text{£/kW}) \times \text{TEC kW} = \text{£ wider TNUoS charge}$$

For the avoidance of doubt the methodology for calculating demand charges would be based on the existing approach.

#### **(ii) Inclusion of HVDC in charging calculation**

When calculating the wider TNUoS tariff utilising the Transport and Tariff model, various AC transmission technologies are modelled in the Loadflow element. This is done in order to include the various unit costs of these technologies into the calculation of the locational signal. Whilst overhead lines and cables of different voltage levels are included no DC technology, outside of the offshore charging methodology, is currently taken account of. With the first of two planned HVDC links (or "bootstraps") committed, the need to be able to suitably represent these links in the methodology is imminent.

Two main issues need to be addressed in order to facilitate HVDC circuits in the charging model:

- (a) The treatment of base case and incremental power flows in the DC load flow element of the charging model, in light of the inherent controllability of flows through an HVDC link that parallels the AC network;
- (b) The calculation of the expansion factor (i.e. relative unit cost) for HVDC circuits.

#### a) Power Flow

It is proposed that the treatment of power flow on an HVDC link in the Transport Model be based on a simplifying assumption. This treatment can be made due to the controllable nature of these links relative to power flows on the AC network, which are dictated solely by the impedance of a circuit and that of the remaining network. As a result, this proposal asserts that the modelling of an HVDC link as an AC circuit, for the purposes of calculating the incremental power flow element of the locational signal, represents a reasonable simplification. This approach requires the calculation of impedance for the equivalent AC transmission circuit (i.e. the circuit characteristic that dictates power flow).

This proposal would calculate the impedance by adjusting the impedance of the HVDC circuit in the DC load flow in order to achieve a pre-determined power flow through it in the base case. This power flow is determined as a proportion of the average circuit ratings of all the circuits comprising the main transmission boundaries that the HVDC circuit crosses. That is, it is assumed that the HVDC circuit is loaded to the same extent on average as the equivalent AC circuits that it parallels.

To achieve this one would first sum the ratings of all transmission circuits that cross each transmission boundary individually, excluding the HVDC circuit itself. Subsequently, the power flow across each boundary without any flow on the HVDC circuit would be used to produce a ratio of power flow to boundary total circuit rating (accounting for the direction of the boundary flow in the base case). These ratios can be used to calculate an average for all transmission boundaries that the HVDC circuit crosses. This average power flow to total circuit rating figure is used to set the impedance of the AC equivalent HVDC circuit to produce the power flow that gives this ratio to the HVDC circuit rating.

#### b) Expansion Factor

The charging methodology incorporates the unit cost of various transmission technologies by calculating the cost of a given technology relative to the cost of 400kV overhead line. This allows for the calculation of a multiplier, known as an expansion factor, which is used in the Transport model to calculate the locational signal within TNUoS charges. As HVDC technology does not currently exist in the Transport model, a method of incorporating its unit cost is also required.

This proposal would introduce a new expansion factor for each HVDC circuit depending on its voltage. In addition, as HVDC converters are an integral element of the distance related locational signal of the link, it is proposed to include the cost of these converters into the expansion factor calculation for each circuit. Currently HVDC converters can be broadly split into two different types, current source converters and voltage source converters, leading to the potential for two additional expansion factor types. Where a different approach is developed through the working group process that is reasonably considered by the proposer to better meet the miscellaneous terms set out in the Authority's direction, it shall be substituted into this proposal in accordance with the proposer's rights under clauses 8.16.10 and 8.20.23 of the CUSC. It is recognised that stand-alone alternatives may also be developed through the working group process.

#### **(iii) Inclusion of Island links into the charging methodology**

A methodology for calculating cost reflective TNUoS charges for transmission spurs connecting generation and demand and comprised of network technology not included in the expansion factors set out in clause 14.15.47 and 14.15.49 of the CUSC, such as those which may be established between the Scottish mainland and the Scottish islands of Western Isles, Orkney and Shetland is not currently included in the methodology.

In order to calculate cost reflective charges for this type of transmission circuit this proposal addresses how the expansion factor should be calculated for underground and subsea technologies not included in the methodology.



As outlined in (ii), above, the charging methodology incorporates the unit cost of various transmission technologies by calculating the cost of a given technology relative to the cost of 400kV overhead line. This allows for the calculation of a multiplier, known as an expansion factor, which is used in the Transport model to calculate the locational signal within TNUoS charges. As the sub-sea and HVDC technologies proposed do not currently exist in the Transport model, a method of incorporating their unit cost is required.

For transmission spurs, such as those connecting Scottish islands, it is proposed to calculate new expansion factors for each type of circuit technology proposed. Where such circuits are comprised of HVDC technology, the methodology would be consistent with that outlined in (ii) above. In addition, where a significant proportion of the spur has no redundancy, but is still deemed to be part of the wider network for charging purposes, the length of that portion of the circuit in the transport model would be adjusted to compensate by multiplying its actual length by 1/(Locational Security Factor). Where a different approach is developed through the working group process that is reasonably considered by the proposer to better meet the miscellaneous terms set out in the Authority's direction, it shall be substituted into this proposal accordance with the proposer's rights under clauses 8.16.10 and 8.20.23 of the CUSC. It is recognised that stand-alone alternatives may also be developed through the working group process. Development of these alternatives should consider any precedents which it may be setting for other aspects of the charging methodology.

**Description of Issue or Defect that the CUSC Modification Proposal seeks to Address:**

*(mandatory by proposer)*

**(i) Network Capacity Sharing**

As a greater proportion of variable, renewable generation connects to the transmission network, the output of many conventional generators has also become more variable in nature. As generators of different types change the way in which they use the transmission network, the nature of transmission capacity investment planning has also altered to ensure efficient investment is undertaken. This is exemplified in the recent changes to the NETS SQSS (GSR-009) and the increasing amount of investment justified on the basis of avoided future constraint costs (i.e. outside of the deterministic NETS SQSS standards). In order to maintain a consistent level of cost reflectivity, Transmission Network Use of System charges must also evolve.

**(ii) Inclusion of HVDC in charging calculation**

With the first of two planned HVDC links paralleling the existing AC network committed, there is a requirement to properly take account of changes in the Transmission business and produce cost reflective tariffs through the ability to represent these links in the charging methodology.

**(iii) Inclusion of Islands links into the charging methodology**

With three links to the Islands of northern Scotland planned in the near future, each of which is likely to be in the form of a transmission spur connecting generation and demand and comprised of network technology not included in the expansion factors set out in clause 14.15.47 and 14.15.49 of the CUSC, there is a requirement to properly take account of changes in the Transmission business and produce cost reflective tariffs through the ability to represent these links in the charging methodology

**Impact on the CUSC:** *(this should be given where possible)*

Significant impact on Section 14 and impact on Definitions. Further impacts to be determined.

**Do you believe the CUSC Modification Proposal will have a material impact on Greenhouse Gas Emissions? Yes/No** (mandatory by Proposer. Assessed in accordance with Authority Guidance – see guidance notes for website link)

Yes

**Impact on Core Industry Documentation. Please tick the relevant boxes and provide any supporting information:** (this should be given where possible)

BSC

Grid Code

STC

Other

(please specify)

Possible impact on STC in order to facilitate acquisition of sufficient data for calculation of expansion factors for technologies used in island links.

**Urgency Recommended: Yes / No** (optional by Proposer)

No

**Justification for Urgency Recommendation** (mandatory by Proposer if recommending progression as an Urgent Modification Proposal)

N/A

**Self-Governance Recommended: Yes / No** (mandatory by Proposer)

No

**Justification for Self-Governance Recommendation** (mandatory by Proposer if recommending progression as Self-governance Modification Proposal)

N/A

**Should this CUSC Modification Proposal be considered exempt from any ongoing Significant Code Reviews?** (mandatory by Proposer in order to assist the Panel in deciding whether a Modification Proposal should undergo a SCR Suitability Assessment)

No ongoing SCRs.

**Impact on Computer Systems and Processes used by CUSC Parties:** (this should be given where possible)

To be considered.

**Details of any Related Modifications to Other Industry Codes (including related CUSC Modification Proposals):** (where known)

CMP207

**Justification for CUSC Modification Proposal with reference to Applicable CUSC Objectives:**  
(mandatory by proposer)

**Please tick the relevant boxes and provide justification for each of the Charging Methodologies affected.**

**Use of System Charging Methodology**

- (a) that compliance with the use of system charging methodology facilitates effective competition in the generation and supply of electricity and (so far as is consistent therewith) facilitates competition in the sale, distribution and purchase of electricity;
- (b) that compliance with the use of system charging methodology results in charges which reflect, as far as is reasonably practicable, the costs (excluding any payments between transmission licensees which are made under and in accordance with the STC) incurred by transmission licensees in their transmission businesses and which are compatible with standard condition C26 (Requirements of a connect and manage connection);
- (c) that, so far as is consistent with sub-paragraphs (a) and (b), the use of system charging methodology, as far as is reasonably practicable, properly takes account of the developments in transmission licensees' transmission businesses.

**Full justification:**

Submitted in order to fulfil the requirements of the direction to NGET by the Authority, arising from the TransmiT TNUoS SCR process. See proposals and defect description, above.

In summary proposals would facilitate more effective competition by increasing the cost-reflectivity of charges, such that users of the transmission network are exposed to the costs they impose by such use. Proposals would also properly take account of developments in the transmission business by evolving with the charging methodology to reflect the increase in intermittent generation, include HVDC technologies that parallel the onshore network and include links to Scottish islands.

**Connection Charging Methodology**

- (a) that compliance with the connection charging methodology facilitates effective competition in the generation and supply of electricity and (so far as is consistent therewith) facilitates competition in the sale, distribution and purchase of electricity;
- (b) that compliance with the connection charging methodology results in charges which reflect, as far as is reasonably practicable, the costs (excluding any payments between transmission licensees which are made under and in accordance with the STC) incurred by transmission licensees in their transmission businesses and which are compatible with standard condition C26 (Requirements of a connect and manage connection);
- (c) that, so far as is consistent with sub-paragraphs (a) and (b), the connection charging methodology, as far as is reasonably practicable, properly takes account of the developments in transmission licensees' transmission businesses;
- (d) in addition, the objective, in so far as consistent with sub-paragraphs (a) above, of facilitating competition in the carrying out of works for connection to the national electricity transmission system.

**Full justification:**

<b>Details of Proposer:</b> (Organisation's Name)	National Grid Electricity Transmission
<b>Capacity in which the CUSC Modification Proposal is being proposed:</b> (i.e. CUSC Party, BSC Party, "National Consumer Council" or Materially Affected Party)	CUSC Party
<b>Details of Proposer's Representative:</b> Name: Organisation: Telephone Number: Email Address:	Ivo Spreeuwenberg National Grid Electricity Transmission 01926 655897 ivo.spreeuwenberg@nationalgrid.com
<b>Details of Representative's Alternate:</b> Name: Organisation: Telephone Number: Email Address:	Andrew Wainwright National Grid Electricity Transmission 01926 655944 andy.wainwright@nationalgrid.com
<b>Attachments (Yes/No):</b>	
If Yes, Title and No. of pages of each Attachment: N/A	

## Annex 3 – Workgroup Attendance Register

Name	Representing	Role	Number of meetings attended*	Able to vote**
Patrick Hynes	National Grid	Chairman	27	No
Jackeline Crespo-Sandoval	National Grid	Technical Secretary	16	No
Ivo Spreeuwenberg	National Grid	National Grid representative	20	Yes
Anthony Mungall	Ofgem	Authority Representative	25	No
Dennis Gowland	The European Marine Energy Centre (EMEC) Ltd	Workgroup Member	26	Yes
Ebba John	DONG Energy Burbo Extension (UK) Limited	Workgroup Member	23	Yes
Frank Prashad	RWEpower	Workgroup Member	23	Yes
Garth Graham	SSE Generation Ltd	Workgroup Member	28	Yes
Helen Snodin	Scottish Renewables / Highlands and Islands Enterprise	Workgroup Member	26	Yes
James Anderson	ScottishPower Energy Management Limited	Workgroup Member	25	Yes
Maf Smith	RenewableUK	Workgroup Member	20	Yes
Mark Cox	EDF Energy	Workgroup Member	21	Yes
Michael Dodd	ESB International	Workgroup Member	19	Yes
Patrick Smart	RES UK and Ireland Limited	Workgroup Member	17	Yes
Paul Jones	E.ON UK	Workgroup Member	25	Yes
Peter Waghorn	Phillips 66 / Immingham CHP LLP	Workgroup Member	24	Yes
Ricky Hill	Centrica	Workgroup Member	24	Yes
Simon Lord	First Hydro Company	Workgroup Member	25	Yes
Stuart Cotten	Drax Power Limited	Workgroup Member	27	Yes
Robert Longden	Mainstream Renewable Power	Workgroup Member	5	No
Nick Kay	Uisenis	Observer	21	No
Adelle McGill	National Grid	Technical Secretary	11	No

\* including Nominated Alternative attendance

\*\* insert criteria for voting

### Nominated alternatives

Nominated Alternative	For Workgroup member	No. meetings attended
Wayne Mullins	Ivo Spreeuwenberg	3
Geoff Randall	Anthony Mungall	4
Angus MacRae	Garth Graham	1
Bill Reed	Frank Prashad	4
Cem Suleyman	Stuart Cotten	12
Graham Pannell	Patrick Smart	2
Paul Mott	Mark Cox	12
Stefan Leedham	Mark Cox	4
Zoltan Zavody	Maf Smith	6
Andy Wainwright	Ivo Spreeuwenberg	13

### Introduction

- 4.1 NGET, as the Proposer of CMP213, presented and circulated a more detailed description of the Original proposals. Following discussion some areas of the Original proposal were clarified and further details of the Proposer's reasoning were included. This more detailed outline of the proposed solution is included as Annex 8 – Detail of Original Proposal.
- 4.2 The network capacity sharing aspect of the CMP213 modification proposal seeks to improve the cost reflectivity of the Transmission Network Use of System (TNUoS) tariffs by recognising transmission network capacity sharing by generators in the Investment Cost Related Pricing (ICRP) TNUoS calculation.
- 4.3 As this aspect of the CUSC Modification Proposal CMP213 Modification Proposal represents a significant change to the existing ICRP calculation, is quite detailed in nature and despite its outward simplicity is based on underlying concepts that can be difficult to conceptualise for non-transmission experts, the Workgroup spent a considerable amount of time discussing, debating and challenging the Original proposal in order to fully understand it.
- 4.4 The current charging methodology for calculating TNUoS tariffs at a given point on the transmission network injects an additional 1 MW at that point, removes it from the notional centre of the transmission network (known as the 'reference node') and uses the resulting increase in network power flows on a MW per MW basis to calculate the locational signal.
- 4.5 In using this approach, the existing charging methodology inherently assumes that 1 MW of generation capacity would require 1 MW of transmission network capacity. Historically, with relatively low generation plant margins above peak demand levels (in the order of 20% to 25%), this has been a reasonably cost reflective assumption.
- 4.6 As generators of different technology types connect to, and change the way in which they use the transmission network, the nature of transmission capacity investment planning has also altered to ensure efficient transmission network investment is undertaken. This is exemplified in the recent changes to the NETS SQSS (GSR-0091) and the increasing amount of transmission investment justified on the basis of avoided future constraint costs (i.e. a cost benefit analysis, CBA approach; outside of the deterministic NETS SQSS standards).
- 4.7 As a result, transmission planners are increasingly making implicit assumptions about the extent to which generators with differing characteristics share capacity on the transmission network, such that 1 MW of generation capacity will not necessarily require 1 MW of transmission network capacity. The assumptions not only include the characteristics of individual generators but the combined characteristics of a group of generation behind a transmission boundary. Transmission planners historically have achieved this by only considering a limited stack of generation (based on merit order) but this is less robust in areas where intermittent generation is present.

---

<sup>1</sup> <http://www.ofgem.gov.uk/Pages/MoreInformation.aspx?docid=26&refer=Networks/Trans/ElecTransPolicy/SQSS>

- 4.8 Under the Original proposal the Transport model would continue to be used to calculate the long run incremental cost at a given connection point on the transmission network. Within the Transport model a dual background approach would be applied, using both a Peak Security and Year Round background, consistent with recent changes to the NETS SQSS under GSR-009 and the Authority's Direction arising out of the TNUoS Project TransmiT Significant Code Review.
- 4.9 It is proposed that locational incremental requirements on a transmission circuit route are allocated to one background or the other; i.e. Peak Security or Year Round; based on whichever drives the maximum flows on that circuit. The Proposer believes that this approach is consistent with the driving factor behind transmission investments.
- 4.10 Under this approach transmission capacity required for Peak Security reasons would be planned and charged in accordance with a generator's Transmission Entry Capacity (TEC), whilst capacity required for Year Round purposes would be charged in accordance with both a generator's TEC and a generator specific sharing factor, based on their historic average annual load factor, which the Proposer believes to be reflective of the efficient transmission network capacity for that particular generator.
- 4.11 Many in the Workgroup believed that the use of a generators' annual load factor for TNUoS calculation purposes was either overly simplistic and not sufficiently cost reflective or that the use of a form of generator annual load factor may be justified as one element of the TNUoS calculation but that it either should not be specific or should not be based on historic information.
- 4.12 A generator specific, rather than generic, annual load factor is deemed necessary by the Proposer to adequately reflect an individual generator's contribution to the need for transmission network capacity investment to the level of granularity required for cost reflective charges (that are non-discriminatory in nature).
- 4.13 In reality when the transmission planner undertakes a CBA there is limited information available and it is therefore necessary to make a number of assumptions about the characteristics of individual generators in the associated market dispatch model. Some examples of these assumptions, as set out above, include the plant's capacity, efficiency, fuel prices, CO2 prices, unavailability due to maintenance and faults, bid prices, offer prices, available subsidies, etc.. The Proposer explained that each of these assumed characteristics, as inputs to the market model, would manifest in a generator's annual load factor, which is an output of the market model.

#### Transmission Planning Using CBA

- 4.14 As the use of market models that dispatch and re-dispatch generation to meet demand and reconcile transmission network constraints are a key aspect of the transmission planning process and as such were also used by the Proposer to demonstrate how the many detailed implicit assumptions on generation characteristics manifest themselves in a generator's annual load factor and how this related to incremental costs, the Workgroup believed it was important to understand how these models worked in principle.
- 4.15 The market model used in the CBA process will use the aforementioned generation characteristic assumptions, along with assumptions about demand levels over the course of a year of operation to calculate an optimum economic despatch of generation to meet demand in each period. Subsequently, this market model will consider the transmission network power flows arising from this optimum economic despatch (OED) against the network capability and re-dispatch generation using the most economic

bids and offers available where necessary to ensure power flows remain within the capability of the transmission network. This process ensures that the total network operational costs are minimised.

- 4.16 This re-dispatch is sometimes referred to as the security constrained optimum economic despatch (SCOED). The difference between the SCOED and the OED for each period summed across a year of operation is known as the annual constraint cost.
- 4.17 The above process of market modelling was also used extensively by the Workgroup to explore and develop the Original proposal in order to address the concerns set out in paragraph 4.11, as set out below.
- 4.18 Individual transmission network reinforcement options are tested in the market dispatch model described above to assess the extent to which they reduce annual constraint costs over a number of future years. A decision to invest in transmission network capacity would occur when the annuitised cost of that investment is less than the forecast reduction in annual constraint costs (and some other benefits such as reduced losses) over a sufficient number of future years. As a result one would expect that transmission network constraint costs (the short run marginal cost – SRMC) and transmission network reinforcement costs (the long run marginal cost – LRMC) would converge over the long term in a given part of the network, all else being equal (i.e. ignoring short term effects such as consenting delays, connect and manage and the ‘lumpiness’ of transmission equipment investment).
- 4.19 It is this CBA method of transmission network planning and the relationship between the SRMC and LRMC of transmission that allows for an investigation of the impact that an additional 1 Megawatt (MW) of generation plant has on constraint costs in order to quantify its incremental network requirements on a network where transmission network capacity is shared. In the Original proposal transmission network capacity is deemed to be shared across the wider transmission network for those incremental network costs driven by the Year Round background in the Transport model.
- 4.20 In search of a method for taking into account the many characteristics of a specific generator in relation to its incremental transmission network requirements, the Proposer undertook a significant amount of market modelling (as described above) using the NGET’s Electricity Scenario Illustrator (ELSI) Model model and a range of assumptions about background conditions based on reasonable forecasts of these conditions also used by NGET when planning transmission capacity. It was not the intention to use this type of modelling to generate produce actual TNUoS tariffs. Rather it was undertaken in an attempt to discover if a simple proxy for a generator’s incremental impact on transmission network costs existed that could be incorporated into the existing ICRP approach. This would avoid the need for complex commercial arrangements to solicit more detailed information from generators, which was shown to be extremely difficult through the TAR industry process.
- 4.21 Within this modelling, undertaken using ELSI, the Proposer concluded that a generator’s annual load factor generally has a linear relationship with its impact on incremental constraint costs although the relationship may vary across different plant types and location due to the fact that the annual load factor is a manifestation of the relative economics of that generator; including its availability, fuel cost, efficiency, CO2 prices and subsidies such as ROCs.,
- 4.22 Whilst the relationship between annual load factor and incremental cost was not a perfect one and varied for different areas of the transmission



system, the Proposer believed that it was much better than the relationship between Transmission Entry Capacity (TEC) and incremental cost, as illustrated in Figure 1 **Error! Reference source not found.**, below

4.23 The blue diamond points on this plot represent the annual incremental cost impact of a generation plant type against its annual load factor as calculated by the ELSI model. The dotted green line represents the theoretically perfect relationship between annual load factor and annual incremental costs; whereas the red dashed line represents the theoretically perfect relationship between a generator’s capacity (i.e. TEC) and annual incremental costs. A similar illustration was shared with the Project TransmiT SCR Technical Working Group in 2011.

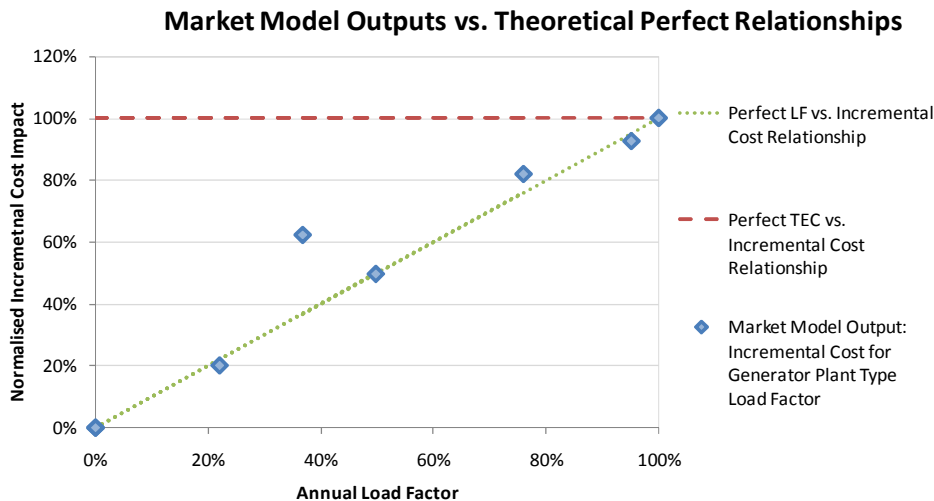


Figure 1 – Market Model Outputs vs. Theoretical Perfect Relationships

4.24 The results of the annual load factor vs. incremental cost analysis, in the form of graphs showing the zonal relationships between an incremental 1 MW of various generation plant types (with various load factors arising out of the market model) and the annual incremental constraint cost implications associated with that generator, were shared with the Workgroup at their second meeting in July 2012. A version of these graphs is reproduced within Annex 9 – ALF vs. Annual Incremental Cost Analysis. Similar graphs were also previously shared with the Project TransmiT SCR Technical Working Group in 2011.

4.25 In addition to the above, a simple user interface was created by NGET for the ELSI model in order to allow CMP213 Workgroup members to undertake similar analysis utilising their own assumptions and test the nature and limitations of this relationship for themselves. An example of the types of graphs shared with the Workgroup and included in Annex 9, are shown below in Figure 2.

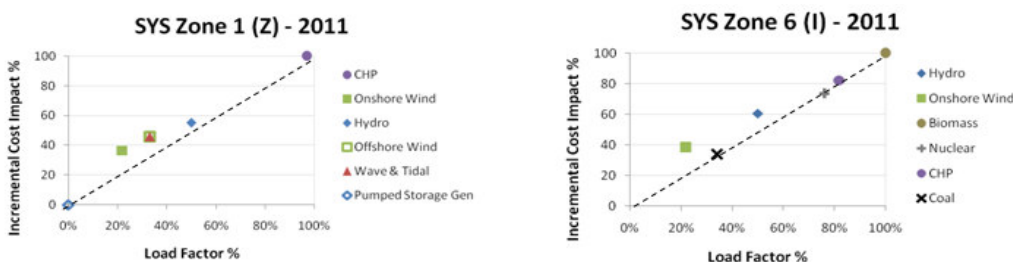


Figure 2 – Example ELSI analysis

4.26 Based on the analysis undertaken, and despite deterioration of the relationship in some areas of the transmission network as shown in Annex 6, and in later years (i.e. beyond 2017/18), the use of generator specific

sharing factors based on annual load factor was thought to be a reasonable, simple proxy by the Proposer, in lieu of requesting and utilising all the aforementioned detailed characteristics, which provides a suitable balance between the cost reflectivity and simplicity of the TNUoS tariff calculation.

## Workgroup Deliberations

- 4.27 The Workgroup was required to consider the issues raised under this aspect of the CMP213 Modification Proposal and were asked to report on the following specific issues in line with / in addition to those set out in the Authority's SCR Direction by the CUSC Panel:
- (a) whether intermittent generation should contribute to the peak element of the tariff;
  - (b) whether load factor is an appropriate measure of the level of sharing;
  - (c) whether the proposed method for calculating load factor is an appropriate measure of forward looking charges (subject to item b);
  - (d) whether to use maximum line flow when attributing circuit MWkm to the Peak Security and Year Round elements or an alternative approach;
  - (e) whether shortening circuit MWkm may be an alternative to the use of load factor in reflecting sharing; and
  - (f) comparison of the modelled charging outputs to real network investment costs.
- 4.28 In the second meeting the Workgroup considered both the terms of the SCR Direction and the specific request from the CUSC Panel and compiled a single list of options and potential alternatives to be investigated from the outset. These are explored further below.

### Initial Scoping of the Original

- 4.29 The Workgroup agreed the areas to be considered for the sharing aspect of the Original proposal could be summarised as:

Considerations from the Direction	Potentials changes to Original
a) How charging structures should be applied geographically; in particular where zones are dominated by one type of generation	i) Account for diversity in a plant type specific manner for each zone
	ii) Account for diversity in a zonal average manner for each zone
	iii) Different treatment for positive and negative charging zones
b) Alternative approaches to ALF for reflecting User characteristics into charging	i) TEC only
	ii) SQSS based generic factor
	iii) Other Generic load factor
	iv) NGET and/or User forecast
	v) Hybrid approach
	vi) Alternatives measures (metered, FPNs)
	vii) Ex-ante or ex-post
c) Whether intermittent technology types should be exposed to the peak element of the tariffs	i) Exposed to some extent
	ii) Indexed linked to something

**Table 1 – Considerations from the Direction for Sharing**

4.30 In developing the Original and potential alternatives of the various themes highlighted in this section further analysis was undertaken by other Workgroup members on market models and concepts were also considered on a more theoretical basis to ensure that results arising from the analysis could be corroborated with what would be expected to happen in theory. This approach also helped all members of the Workgroup to better understand the concepts behind the Original proposal and potential alternatives by breaking it down into its component parts.

Areas for development of Original Proposal and Potential Alternatives

4.31 The Workgroup also discussed further areas where the Original proposal could be developed not highlighted by the Authority’s Direction or where potential alternatives could be developed and discussed each of these in turn.

Potential Alternatives
i. Sharing applies to local
ii. Method of allocation of MWkm to YR and PS backgrounds
iii. Don’t have a dual-background (YR only)
iv. Use of a full market model to calculate charges (more than 2 backgrounds)
v. Background scaling different to GSR-009
vi. Anticipatory application of sharing (or wider)
vii. Explicit sharing
viii. Incorporating circuit loading (e.g. LRIC) into methodology
ix. Application of load factor (or variant) to residual as well as year round
x. A method to recover more revenue through the locational element of tariffs
xi. Alternative zoning methodology

**Table 2 – Potential Alternatives for Sharing**

Discussion on the Original Proposal and Potential Options and Alternatives

4.32 This section covers the Workgroup discussions on each of the individual issues above. It does so by setting out details of the Workgroup views expressed during the explanation and development of the proposal before taking each of three main considerations from the SCR Direction (set out in Table 1, above) in turn, with each of the potential changes to the Original Proposal covered under these main considerations. Finally, the potential alternatives set out in Table 2 **Error! Reference source not found.** are also considered in turn.

4.33 As set out above, the use of generator’s annual load factor as a surrogate for the incremental cost of transmission network investment (driven by constraint cost) is at the heart of the Original proposal. The Proposer believes a generator’s annual load factor, as a manifestation of many underlying variables, was a simplification of the relationship between generation plant type and incremental transmission cost but that it was better than the use of generation (TEC) capacity alone and represented the right balance between simplicity and cost reflectivity in the TNUoS tariff calculation.

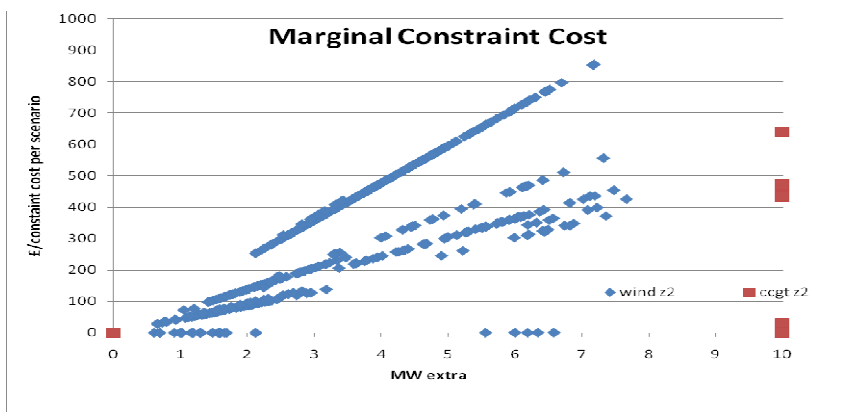
4.34 A number of concerns were raised by some Workgroup members that, although the initial view of the Proposer was that the use of a generator’s annual load factor alone provided the right balance between simplicity and cost reflectivity, in many circumstances this was believed not to be the

case by these members. These members believed that a number of key issues needed to be explored further.

- 4.35 These members pointed out that in those TNUoS charging zones where there was little or no diversity of generation plant type, the relationship between a generator's annual load factor and incremental constraint costs shown by the Proposer appears to deteriorate, with some generation plants types driving higher constraint cost. This was linked to concerns that the absolute value of avoided constraint costs vary depending on the generation (TEC) capacity and type of plant in a TNUoS charging zone. Some believed that zones dominated by low carbon generation plant had constraint costs that are high relative to zones dominated by conventional thermal plant.
- 4.36 It was also believed by some that the difference between bid and offer prices is the driver of constraint costs in areas of the transmission network behind constrained transmission boundaries, which are typically also positive TNUoS zones, whereas differential offer price is the main driver in unconstrained areas of the transmission network and that avoided constraint costs are not significant in these areas, which are also typically negative TNUoS zones.
- 4.37 Linked to the above concerns, some Workgroup members were concerned that the Original proposal does not consider the different characteristics of different transmission network boundaries and simply assumes the generator's annual load factor effect on all transmission network boundaries is identical. The Proposer clarified that the Original proposal currently only differentiates based on the distance related aspect of the signal (which changes by boundary) and the generator specific sharing factor, but not based on the relative capacity of generation plant types in a TNUoS charging zone.
- 4.38 Others in the Workgroup believed that, as the investment in the transmission network is forward looking and investments are made by TOs to avoid incurring future potential significant constraint costs it may thus be prudent to include "future" generation plant in a potential alternative that takes capacity of generation by plant type into account when sharing of transmission network capacity is identified. It was not clear to the group, at this stage, how future generation plant would be identified and how this could be incorporated into the TNUoS charging methodology.
- 4.39 Some members in the Workgroup were also of the view that the methodology used to incorporate recent changes to the NETS SQSS by splitting the tariff into Peak Security and Year Round elements is overly complex and were unsure if the resulting separate incremental cost signals are meaningful (or mathematically robust) given that they are based on different load flows. The Proposer believed that the detail of the TNUoS tariff calculation in the Original, included in this consultation as Annex 8 – Detail of Original Proposal, was mathematically robust and reflective of the way in which the transmission network is planned.
- 4.40 A review of the generation annual load factor versus incremental constraint cost graphs presented to the group by the Proposer and some initial exploratory analysis by another Workgroup member in a separate market model to that used by the Proposer confirmed that a number of the aforementioned concerns were potential issues with the Original proposal in the view of some Workgroup members and subsequently formed the basis of further analysis.
- 4.41 As set out above, the graphs produced by the Proposer in support of the Original plot the annual load factor of a generator of a certain plant type against the impact of an incremental 1 MW of that generation plant type on

the annual constraint costs, as it is these total annual constraint costs against which transmission network capacity is planned. However, when modelling the various demand levels across a year of operation, a market model will use multiple snapshots of demand and dispatch/re-dispatch generation against each snapshot. The results of each snapshot are added together to obtain the annual impact.

- 4.42 The graph in Figure 3, below, shows some indicative findings from the generic market model used by Workgroup members referred to above (i.e. not the ELSI model) for constraint cost in a northern SYS zone in a future year. The chart shows the relationship between the output of an incremental 10MW of capacity of a given generation plant type (CCGT and Onshore Wind) and the additional constraint costs arising as a result of that incremental output for each demand snapshot, representing a finite period in a year of operation. From this graph the Workgroup noted that, across a single transmission boundary, multiple generator annual load factor relationships occur at the various demand levels (and associated generation dispatches) that each snapshot represents.
- 4.43 Some in the Workgroup believed that the graph in Figure 3 confirmed that a generator's annual load factor was a key factor, if not the only factor, in the impact on incremental constraint costs.
- 4.44 The Workgroup discussed the fact that the aforementioned relationship is driven by factors including the severity of the constraint (i.e. the volume of energy that cannot be transported on the transmission system) and the type of generation plant used to relieve the constraint (i.e. the price at which that volume of energy is replaced), amongst other factors. Some Workgroup members requested clarification on the input assumptions used within the generic market model, used to produce the results in Figure 3 through Figure 5.

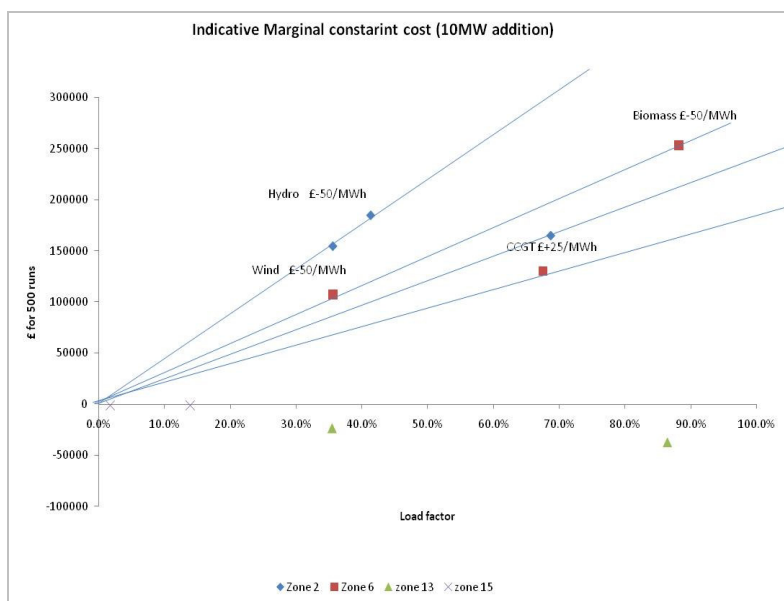


**Figure 3 – Graph of Incremental Constraint Cost vs. Generator Output (for a given snapshot across a year of operation in a positive TNUoS zone)**

- 4.45 Some Workgroup members believed that the Proposer's analysis in support of the Original proposal only considered the simple condition of a relatively unconstrained transmission boundary that had ample quantity of thermal generation units present to relieve the constraint. However, the Proposer clarified that the analysis undertaken was done using National Grid's Gone Green background of generation and demand and with transmission network boundary capacities as close to the optimum level of capacity (where the SRMC and LRMC of transmission converge and consistent with the ICRP approach to taking account of network expansion) as possible for the simplified zonal representation of the transmission network used within these types of market model.
- 4.46 In addition the Proposer agreed, as set out above, that the relationship between a generator's annual load factor and its impact on incremental

constraint costs deteriorates somewhat over time as the proportion of generation plant with high bid prices increases in areas of the transmission network. This effect was also evident from the Proposer's own analysis using the ELSI model and the graphs created using the Gone Green 2020 background shared with the Workgroup.

4.47 Further exploratory analysis was undertaken by Workgroup members in the generic model which looked at the total annual incremental constraint cost across several transmission boundaries (i.e. the entire network), similar to that undertaken by the Proposer. This analysis was undertaken on a generic future generation and demand background with existing transmission network boundary capabilities. This showed that in general the more constrained the boundary (SYS Zone 2 and Zone 6 – in Scotland) and the more negative the bid price of a generation plant type, the greater the incremental constraint cost. The results are illustrated below in Figure 4 below.



**Figure 4 – Total Annual Incremental Constraint Cost against Annual Load Factor**

4.48 For southern zones (SYS Zone 13 and Zone 15) where there are in general fewer network constraints the generation annual load factor relationship was considered by some to be relatively weak and the magnitude of the “saving” (i.e. reduction in incremental constraint costs as a result of offsetting constrained volumes from the north) small compared to the increase in incremental constraint costs evident in northern SYS zones. This effect was deemed by some to be driven by the differential offer price of units used to relieve constraints.

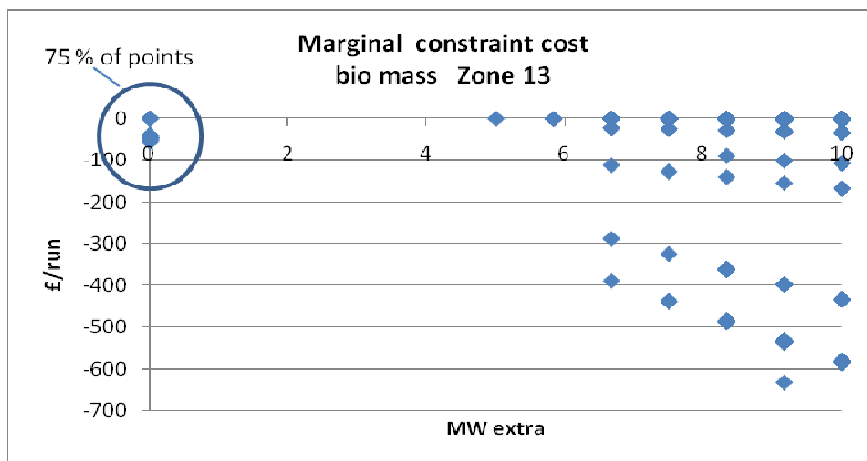
4.49 Others in the Workgroup believed that the slope of the generator's annual load factor versus incremental constraint cost relationship would be dictated by the optimum transmission network boundary capability upon which the Original proposal is based and the distance from the TNUoS charging zone under consideration to the centre of demand on the transmission system (i.e. the number of transmission boundaries that the incremental power flow is likely to cross). Some also considered that the reduction in incremental impact in southern charging zones is consistent with the TNUoS price signal which is lower in the south relative to the north of Great Britain.

4.50 In zones where TNUoS generation charges are negative different relationships between the output of an incremental 10MW of generation capacity and incremental constraint costs per demand snapshot were again seen, as illustrated in Figure 5, below. The Workgroup noted that,



for the majority of snapshots in this analysis the incremental 10 MW of generation was not being dispatched to meet demand and therefore had little or no effect on the incremental constraint cost. Only snapshots at times of high northern constraint cost delivered significant negative values of incremental constraint cost impact. Some in the Workgroup believed that this effect was indicative of a better relationship between generation annual load factor and incremental transmission network costs than that between generation capacity (i.e. output over three peak periods for generators in negative TNUoS charging zones) and incremental transmission network costs.

- 4.51 The Workgroup was interested in the fact that some snapshots of generation dispatch (i.e. optimum economic dispatch) and re-dispatch (i.e. security constrained optimum economic dispatch) delivered values even at a zero generator annual load factor. The group considered that this was likely to be driven by the increased availability of low price offers for generation plant such as the biomass unit illustrated in Figure 5, below. Some Workgroup members were unsure of the input assumptions used, which led to a biomass generator with a 25% annual load factor (i.e. 75% of points at zero output). These members pointed to the ELSI analysis where the annual load factor of biomass generators is much higher.



**Figure 5 – Incremental Constraint Cost vs. Generator Output (for a given snapshot across a year of operation in a negative TNUoS zone)**

- 4.52 It became clear to some Workgroup members during this development phase that sharing of transmission capacity in an area of the transmission system may be best achieved when the coincidence of running between generation (simultaneous running) is lowest. Thermal generation (such as coal and gas) is usually driven by market conditions, has full control of its input fuel and as such in general follows the demand curve. Low carbon generation (principally hydro, wind, wave and tidal) with their lower variable costs and variable input fuel sources are less correlated to demand and in typically operate in a must- run condition when fuel is available.
- 4.53 The Proposer noted that the Original proposal seeks to reflect the impact of generators of different plant type on incremental transmission network cost and does so based on an implicit underlying assumption that individual generators share transmission network capacity (i.e. do not run simultaneously, or ‘counter correlate’, running to a certain extent). The Proposer considered that this implicit assumption was consistent with those made by transmission network planners through the market models used to undertake cost benefit analysis and that the assumption is robust across the main interconnected transmission system.
- 4.54 Some Workgroup members believed that maximum sharing occurs when an area of the transmission system contains an equal amount of generation capacity of both low carbon and conventional thermal

generation and that the optimum transmission boundary capacity would be 50% of the combined capacities. In practice such perfect sharing would not occur and at times some constrained action (i.e. re-dispatch of generation at an additional cost or SCEOD as set out in paragraph 4.16 would be required. In these circumstances a slightly higher volume of thermal plant to low carbon would reduce incremental constraint costs.

4.55 The saving in constraint cost compared to the impact of a full incremental 1 MW achieved by collective sharing of capacity across transmission boundaries is not only dependent on the volume that can share but the length of the boundary and thus the kilometres saved by sharing needs to be considered across transmission boundaries in addition to the volume that can potentially share. Further work was identified to potentially incorporate the volume that can potentially share behind a transmission boundary, the length of the boundary and the generator's annual load factor into a potential alternative based on a single background. This work is set out in more detail, below.

**a) How charging structures should be applied geographically; in particular where areas are dominated by one type of generation**

4.56 As noted above the Proposer undertook a significant amount of market modelling using the Electricity Scenario Illustrator (ELSI) model and a range of assumptions about background conditions in search of a method for taking into account the many characteristics of a specific generator in relation to its incremental transmission network requirements.

4.57 The convergence of long run (i.e. asset) and short run (i.e. constraint) costs on average over the long term when planning incremental transmission network capacity using a CBA approach was used, such that the relationship between a generator and incremental constraint costs arising out of a simple market model would be valid in its application to TNUoS tariffs calculated on the basis of incremental asset costs in the ICRP approach.

4.58 From this ELSI based analysis the Proposer believed that a simple proxy for a generator's incremental impact on transmission network costs existed in the form of its annual load factor and that this proxy could be incorporated into the existing ICRP approach in order to improve the cost reflectivity of this approach. The Proposer suggested this was because load factor is a manifestation of individual generation plant characteristics compared to the wider market operation.

4.59 As part of the analysis it also became clear that the relationship between a generator's annual load factor and incremental transmission network costs deteriorates over the long term in some areas on the extremities of the transmission system where one generation plant type dominates. This effect was corroborated by analysis undertaken by other Workgroup members, set out above, on a separate market model. However, given the uncertainty of when future generation will connect and where, it was difficult for the Workgroup to establish when the deterioration would become significant. Some Workgroup members believed that the relationship does not hold from the outset, regardless of background conditions.

4.60 The Proposer currently believes that the simplicity of a simple generator's annual load factor based approach outweighs any cost reflectivity benefits that a more complex approach taking account of generation plant diversity could bring.

4.61 The Workgroup began an investigation of the issue of generation plant diversity by investigating the annual load factor versus incremental

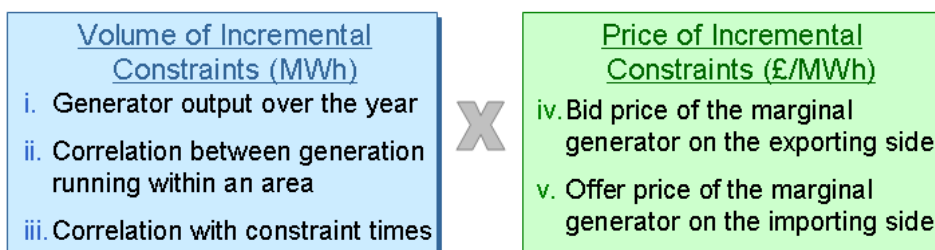


constraint cost relationship. During this investigation the Workgroup expressed concern at the underlying complexity behind the results of the analysis, arising from the number of variables affecting the outcome. This made the graphs difficult to interpret in a Workgroup setting without a more thorough understanding of the underlying variables and their effect.

- 4.62 In advance of the Workgroup and in anticipation of such a concern, a simple to use interface was created for the ELSI market model in order to allow Workgroup members to undertake similar analysis utilising their own assumptions and test the nature and limitations of this relationship for themselves.
- 4.63 The capabilities of this interface and the underlying ELSI market model were improved based on feedback from the Workgroup by increasing the granularity of transmission network boundary modelling, inclusion of maintenance outages in annual network capabilities and the development of a whole new add-in to calculate generation availability probabilistically.
- 4.64 In addition to the use of the above ELSI model with associated interface created specifically for the CMP213 Workgroup process and a separate, generic market model that showed broadly consistent results the Workgroup also engaged in a detailed discussion of the underlying variables and their effects.

Exploration of Variables Affecting Incremental Constraint Costs

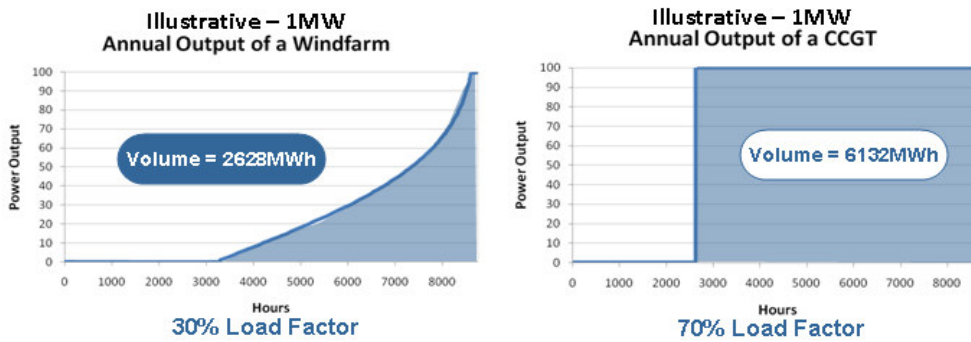
- 4.65 As the impact on incremental constraint costs are used to quantify the impact a generator with certain characteristics has on the need for transmission network capacity, the Workgroup considered that an understanding of what contributes to constraint costs is essential.
- 4.66 The Workgroup agreed that annual incremental constraint costs for a generator with a given TEC (i.e. £/MW/annum) are comprised of 2 main components, illustrated below in Figure 6 which could be further sub-divided into 5 variables.



**Figure 6 – Components that drive transmission constraint costs**

*i) Generator output over the year*

- 4.67 The Proposer believed that the output of an incremental MW of a generation type in a given area of the transmission network over a year of operation is the primary contributing factor to the impact of that unit on the volume of incremental constraints on the Main Interconnected Transmission System. Different generation types have quite different outputs as is illustrated very simplistically between Wind and CCGT in Figure 7, below.

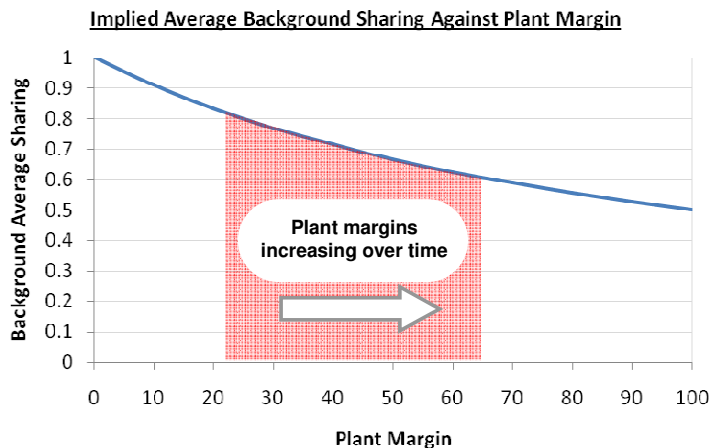


**Figure 7 – Simplistic illustration of output from different types of generation**

- 4.68 The output of some generation plant types, such as wind, is largely dominated by the availability of its fuel (i.e. the wind). Due to the economics of wind plant and subsidies available for this plant type it is assumed that it will always seek to run when the wind is available. However, the output of other plant types such as coal and gas is driven more by short run marginal costs relative to other generators and demand levels. For example, when it is windy coal and gas generators are less likely to be called upon to run. In addition, when conventional plant do run they are more likely to run at full output as this is when they are at their most efficient; compared to wind plant by contrast, which is likely to only be at full output for a small proportion of the year.
- 4.69 All else being equal, a CCGT with a 70% load factor will drive a greater volume of constraints because of longer periods of running than a wind farm of the same MW capacity as shown in Figure 7 above. As noted previously, the Workgroup understood that this largely assumes that there is sufficient diversity of generation plant types behind the transmission boundary. For the avoidance of doubt this is the generator's annual load factor; some members of the Workgroup believed that daily or weekly generator load factors were more important. The Proposer noted the Original proposal does not seek to introduce sub annual measurements or of generator load factors in to the TNUoS tariff calculation.

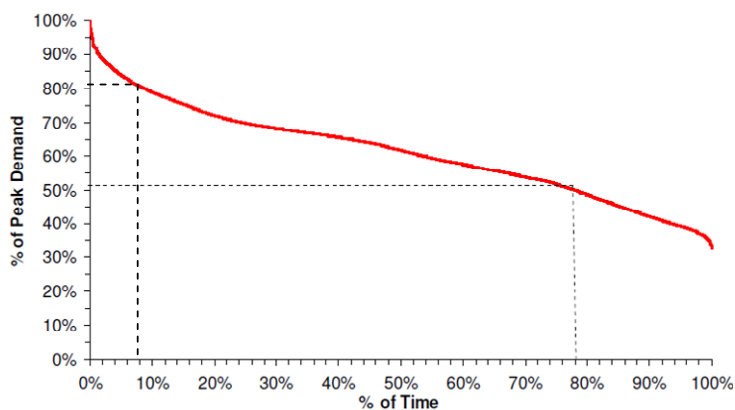
*ii) Correlation between generation running within an area*

- 4.70 In making the implicit assumption that an additional 1MW of generating plant would require an additional 1MW of transmission network capacity, the existing charging methodology makes the simplistic assumption that all plant running is 100% correlated (at peak demand times).
- 4.71 However, if considered from a transmission system wide perspective, it can be simply appreciated that this cannot be the case at times of peak demand, let alone when moving further down the generation price curve at times of lower demand (when planning transmission capacity based on potential avoided constraint costs).
- 4.72 This is illustrated in Figure 8, below, which plots the background average sharing (scaling of generation capacity) at times of peak demand against the percentage of generation capacity installed on the transmission system over and above peak demand (i.e. the plant margin).



**Figure 8 – Transmission Network Sharing at Peak Demand as Plant Margin Increases**

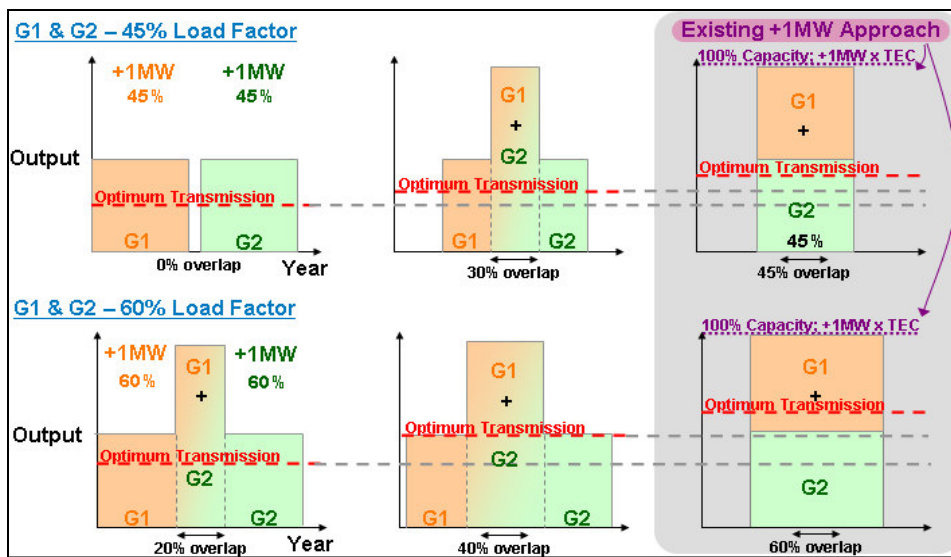
- 4.73 As an example, this figure shows that if the capacities of all generating plant were stacked up against peak demand (i.e. the Plant Margin) and together exceeded that peak demand level by 40%, the generation plant capacity stack would need to be scaled by  $100/140$ ,; i.e. 71.4%,; in order meet the peak demand.
- 4.74 As a 40% plant margin is not far from the existing background conditions it is clear from a transmission system wide perspective that, on average, 1MW of transmission network capacity would not be required for 1MW of generation capacity. Indeed, at times of peak demand this value is closer to 0.7MW on average across the transmission system. Taking account of annual variations in demand entails even greater average background sharing of transmission capacity as peak demand levels only occur in very few of the 8760 hours that make up a year.



**Figure 9 – Annual Demand Load Duration Curve**

- 4.75 Figure 9, taken from the Seven Year Statement, shows that transmission system demand levels are only above 80% of peak levels for 8% of the year and above 50% of peak levels for 78% of the year. The Proposer believes that Figure 8 and Figure 9 taken together demonstrate that a significant amount of sharing of transmission network capacity would take place on average across the transmission system as a whole over a year of operation.
- 4.76 Nevertheless, the Workgroup noted that in areas of the transmission network where there was only one type of generator, and particularly where it was expected to have a negative bid price, transmission network planners would tend to build a level of transmission capacity closer to the full output of those generators.

- 4.77 Due to the aforementioned changes to the way transmission network capacity is planned, the efficient level of network capacity for 1MW of generation capacity is dependent on the characteristics of an individual generating plant in relation to other plant on the transmission network. As network planning becomes more CBA driven, generation plant specific economics can lead to varying levels of efficient transmission network capacity.
- 4.78 When planning a transmission network for year round conditions, consideration of generation plant running across a year of operation is required, indeed, network planners need to make assumptions about running several years in advance. In practice it is the assumptions on individual characteristics of generating plant such as price and availability that will drive its running in the market model used to undertake the CBA. Simplistic illustrative examples of how correlation and counter correlation can occur between two generating units over a year are illustrated in Figure 10.



**Figure 10 – Examples of Plant Correlation**

- 4.79 The above simplistic illustration demonstrates that correlation of running between two co-located incremental 1MW of generation plant is dependent on both the load factor of that generator and the times of the year that they choose to run.
- 4.80 It can be seen that an incremental 1MW with a load factor of <50% (the top plots) have the ability to completely counter correlate (top left) and to completely correlate (top right) their output. The latter being the current assumption within the current ICRP charging approach. Generation plant with a load factor of >50% (the bottom plots) do not have the ability to completely counter correlate (bottom left), but do have the ability to completely correlate (bottom right).
- 4.81 All else being equal, in each of the examples illustrated, the optimum incremental transmission network capacity for one incremental MW of generation would never reach one whole MW of transmission network capacity. Whilst correlation of generation plant running has an impact, on the Main Interconnected Transmission System this is due predominately to the effect of price and availability, which both strongly influence a generator's annual load factor (i.e. its output over the year).
- 4.82 The Proposer noted that the effect of correlation of generation plant running on incremental constraint costs is reflected in the market modelling undertaken and shared with the Workgroup.

iii) Correlation between generator running and network constraint times

4.83 The final variable affecting the impact of an incremental 1 MW of generation on the volume of constraints is the correlation between generation plant running and times of transmission network congestion over the year. The times of network congestion are influenced by demand in a given area of the network and the availability of network capacity connected that area to the rest of the network.

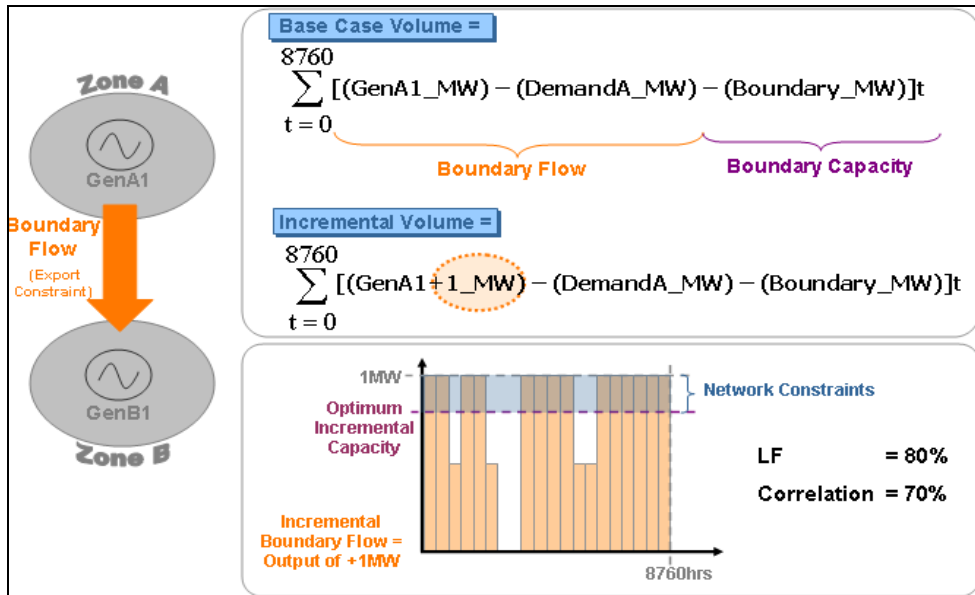


Figure 11 – Correlation between plant running and network congestion

4.84 Consistent with the existing ICRP approach, the investigation into the impact on incremental constraint costs assumes that the transmission network can be expanded to exactly the optimum incremental capacity required.

4.85 Figure 11, above, illustrates how the output of an incremental 1MW of generation in an export constrained zone (GenA1\_MW) interacts with the capacity of the transmission network out of that zone (Boundary\_MW) over the 8760 hours that make up one year of operation.

4.86 The diagram shows that the output of the incremental 1MW over the year (i.e. its annual load factor) is again the predominant factor contributing to the incremental volume of transmission network constraints arising from transmission boundary flows over and above the optimum incremental boundary capacity. Nevertheless, the bottom right plot shows that correlation with times of constraint is also a secondary significant contributing factor.

4.87 This plot demonstrates that, whilst a generator may have an annual load factor of 80% over the 20 periods representing a year (made up of full output over 14 periods, half output – e.g. one unit unavailable – for 4 periods and no output – e.g. not dispatched – for 2 periods), for the periods when it is generating at only 50% capacity (i.e. < optimum incremental network capacity) mean that it does not contribute to constraints during these 4 periods, leading to a correlation with times of constraint of only 70%.

4.88 As shown simplistically above in Figure 11, a wind generator is much more likely to generate at less than full capacity throughout the year due to variability of wind and turbine power characteristics than a base load conventional generator, which will generally run at full output when in merit due to the efficiency gains in doing so.

- 4.89 All else being equal, in each of the examples illustrated, the optimum incremental transmission network capacity for one incremental MW would never reach one MW of transmission capacity on the Main Interconnected Transmission System. Whilst correlation with times of constraint has an impact, this is due predominately to the effect of the generation plant's annual load factor (i.e. its output over the year) as optimum incremental capacity would also reduce with load factor.
- 4.90 The Proposer noted that the effect of correlation with times of transmission network congestion on incremental constraint costs is reflected in the market modelling undertaken and shared with the Workgroup as this modelling varies demand levels, generation availability and transmission network availability throughout a year of operation.

- iv) Bid price of the marginal plant on the exporting; and  
v) Offer price of the plant on the importing side

- 4.91 The second main component of overall constraint costs is that of constraint price (£/MWh). Using the same simple example as in the section above, Figure 12, below illustrates how the Offer price (GenB1\_£/MW) and Bid price (GenA1\_£/MW) combine to create the constraint price for each of the 8760 hours in a year.

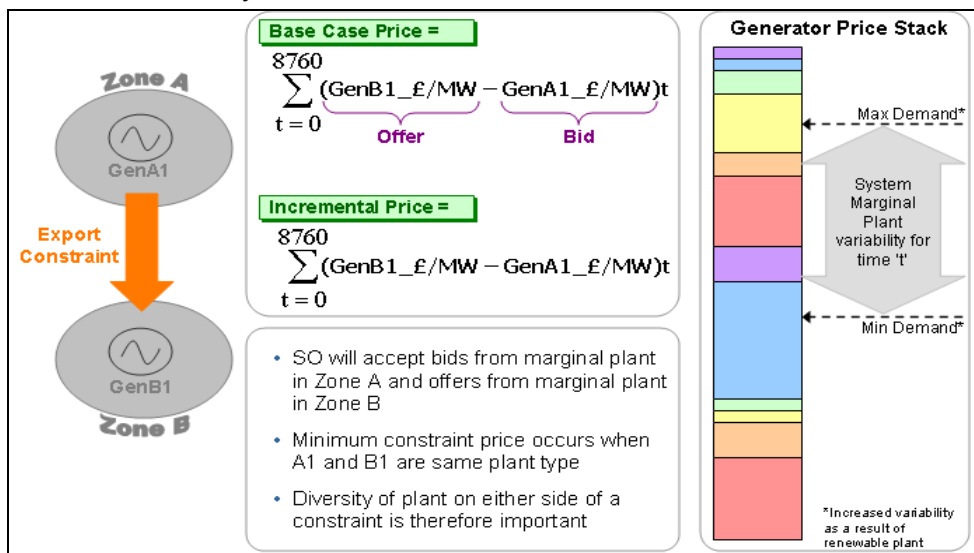


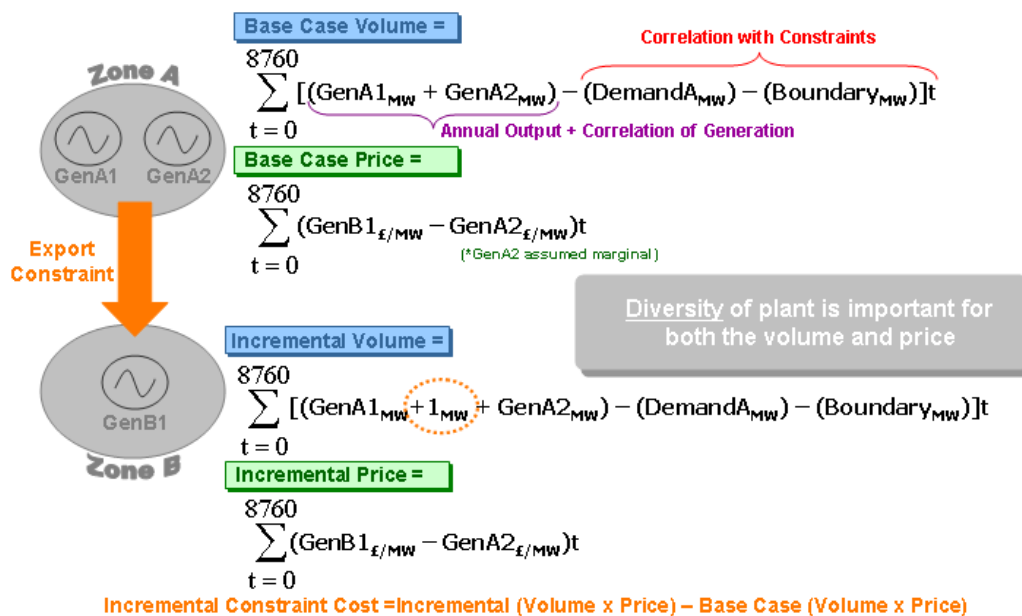
Figure 12 – Impact of bid and offer price on incremental constraint cost

- 4.92 For an export constraint the System Operator (SO) will accept bids from the marginal generation plant on the exporting side (of a transmission boundary) to reduce output and hence power flows across the congested section of the transmission network. In order to maintain the supply and demand balance the SO is also required to accept offers from the marginal generation plant on the importing side of a transmission boundary (assuming a balanced system – signals on system balance are delivered separately through the BSC). In theory the minimum price of this action typically occurs when bids and offers are accepted from the same generation plant type.
- 4.93 The illustration of the generator price stack (or merit order) on the right side of Figure 12, shows that for a given level of demand one generation plant will set the system marginal price. As this price is largely driven by fuel and other variable costs it is likely that there are other generators of a given similar type across the transmission system with will have very similar prices and these are bunched together and illustrated by the various colours on the stack.
- 4.94 Across a year of operation, different generation plant types will set the marginal price (increasing as one moves from the bottom to the top of the



stack up to the marginal generator). This varies depending on both the total demand in a period and the availability of generation at the bottom of the price stack (e.g. wind) in a period.

- 4.95 When a constraint occurs in an area of the transmission network, the transmission system is essentially split into two from the perspective of the SO, due to being compelled to accept bids and offers from a reduced, limited pool of generation on either side of the congested transmission boundary.
- 4.96 Given the above, the Workgroup agreed that sufficient diversity of generation plant was an important factor contributing to the price and volume, and therefore cost, of incremental constraints.
- 4.97 The combined effect of all the above variables is illustrated in Figure 13, below.

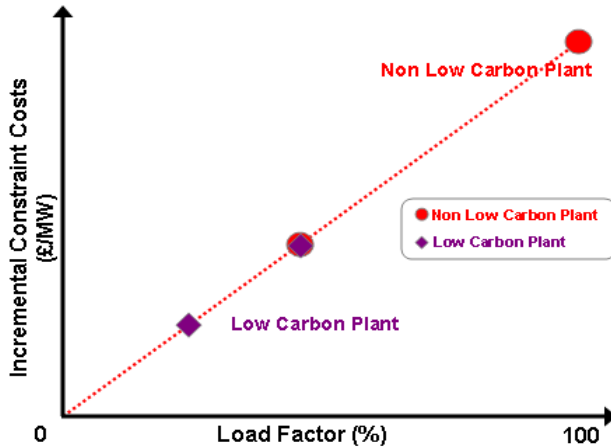


**Figure 13 - Overall cost of a constraint**

- 4.98 The Proposer noted that the effect of bid and offer prices on incremental constraint costs is reflected in the market modelling undertaken and shared with the Workgroup. Indeed the Workgroup noted that, where the relationship between incremental constraint costs and generation annual load factor was shown to deteriorate in future years, that this was largely in areas with increasing proportions of low carbon plant. Some members of the Workgroup noted that this effect was due to the characteristics of low carbon plant, in particular their relatively high bid prices, driven by low fuel prices and volume related subsidies.
- 4.99 Other members of the group disagreed noting that, whilst this may be the case for intermittent plant, that the bid prices of low carbon nuclear (driven by technical and safety related restrictions) are substantially different to those for (intermittent) wind (driven primarily by volume based subsidies). These members believed that a more granular distinction between generation plant types would be required as a result.
- 4.100 However, the Workgroup were minded not to look for a complex solution based on bid price.

Impact of Variables Affecting Incremental Constraint Costs on Generation Annual Load Factor vs. Annual Incremental Constraint Cost Relationship

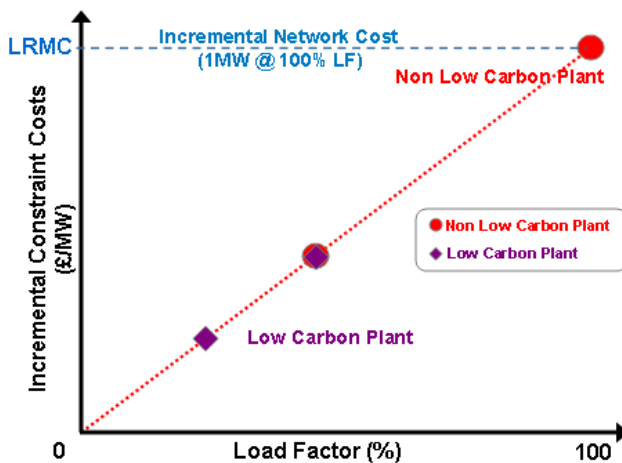
4.101 The Workgroup continued by investigating the effect of the variables contributing to incremental constraint cost on the generator’s annual load factor vs. annual incremental constraint cost relationship upon which the Original proposal is based. This investigation began with consideration of an illustrative version of this relationship, as shown below in Figure 14. The Workgroup noted that for simplicity the relationship was drawn as a perfectly linear one, but that this did not reflect the graphs shared with the Workgroup by the Proposer.



**Figure 14 – Load Factor vs. Incremental Constraint Cost**

4.102 Nevertheless, the majority of the Workgroup noted that the graphs presented by the Proposer did show that the relationship between a generation plant’s annual load factor (% output over a year) and annual incremental constraint costs is a relatively strong one where sufficient diversity of plant type exists. Some in the Workgroup believed that, after having considered the full range of variables contributing to incremental constraint costs, as set out above, this is due to the fact that the primary factor of cost is the unconstrained dispatch of generation over the year. A minority in the Workgroup were still unconvinced that there was any relationship between generation annual load factor and constraint costs.

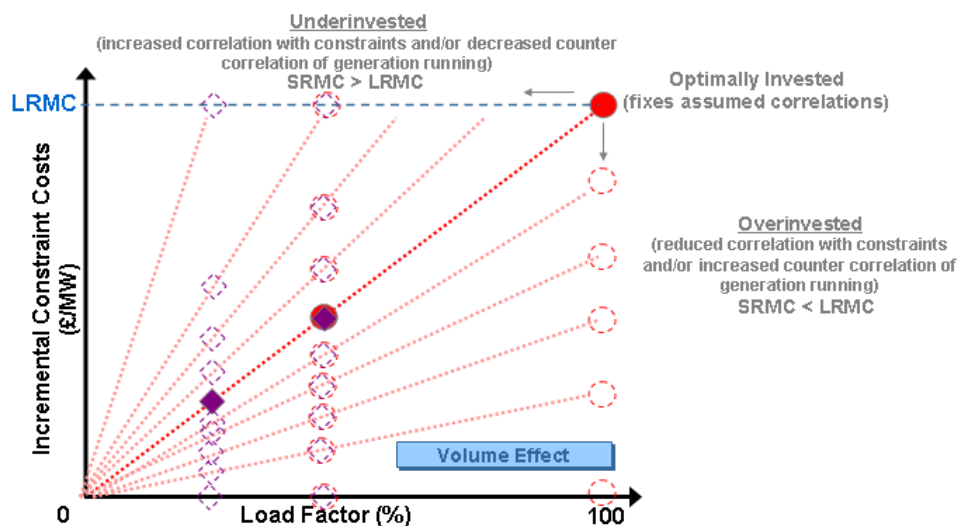
4.103 The Workgroup also recognised that, where this relatively linear relationship exists, the incremental constraint costs (i.e. short run marginal cost) caused by a generating plant with a 100% annual load factor (i.e. one that generates at full capacity for 8760 hours in a year) would set the maximum efficient incremental transmission network costs (i.e. long run marginal cost) for one incremental MW of transmission network capacity, as illustrated below in Figure 15.





**Figure 15 – CBA driven incremental network costs for one incremental MW of network capacity**

- 4.104 From this starting point, the Workgroup began to explore the volume and price component effects, set out above, on the generator’s annual load factor vs. incremental constraint cost relationship.
- 4.105 The illustration in Figure 16, below, shows the effect of changes in the correlation between generation plant running and of generation plant running at times of transmission constraints as set out in paragraphs 4.70 through to 4.90.

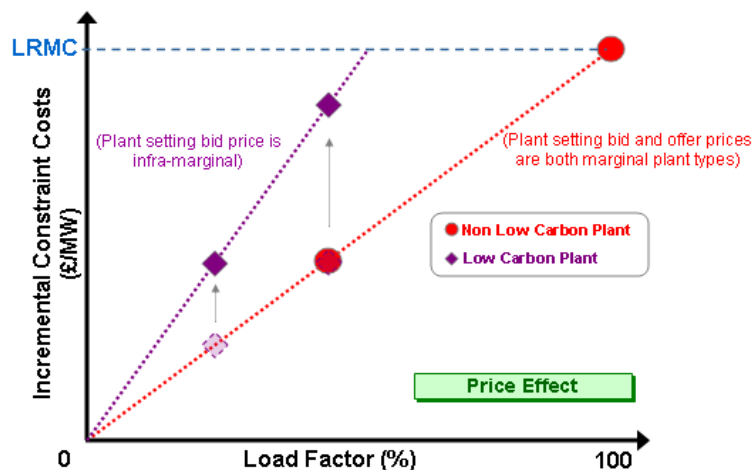


**Figure 16 – Correlation of generation plant running and with times of constraints**

- 4.106 The varying slopes of the dotted lines on the above illustration show that, whilst a change in correlation of generation plant running or with times of transmission constraint has an impact on the slope of the overall linear relationship, such that a 1MW of a given plant type causes more or less incremental constraint costs, it would not negate the relationship between the generator’s annual load factor and annual incremental constraint costs. (i.e. generation plant with lower load factors have a lesser impact on incremental constraint costs even when the slope is higher or lower).
- 4.107 From this, the Workgroup agreed that when the transmission network capacity is set to that of an optimally invested network, the aforementioned correlations between generation plant running and times of constraint are fixed. The Proposer noted that the slope of this line is dictated by the long run marginal cost of an incremental 1MW of fictitious generation with 100% annual load factor and the impact of this 100% annual load factor incremental 1MW is comparable to the impact of an incremental 1MW using the ICRP method in the Transport model.
- 4.108 Given the above, the Proposer believes that it is clear that a generating plant’s annual load factor is one of the primary drivers of incremental transmission network costs when network capacity is planned using cost benefit analysis against future potential savings in constraint costs and it is assumed the network can be expanded in an optimum incremental manner (the latter of which is an existing assumption in the ICRP approach).
- 4.109 In addition to the volume effect on the generation annual load factor vs. incremental constraint cost relationship, the Workgroup also explored the price effect. In this area results from two sets of analysis undertaken using ELSI and a generic market model showed very similar results.
- 4.110 The Workgroup found that, where there was insufficient diversity of generation plant types behind a transmission network constraint, the SO

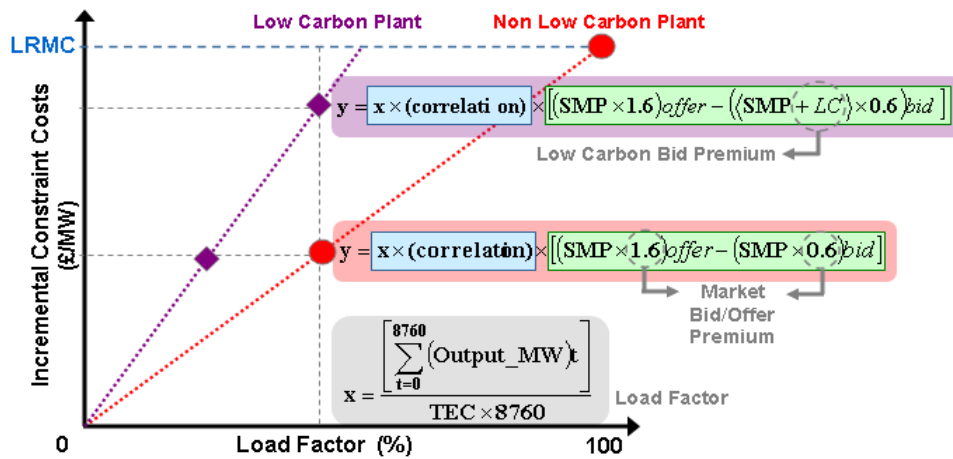
would no longer be able to accept bids from a generator close to price of the system marginal plant. In this case the incremental cost of constraints would increase.

- 4.111 When the Workgroup delved deeper into the nature of this effect, it became clear that the generation plant setting the bid price was the primary factor affecting the price of constraints. Indeed, the Workgroup found that it was possible to broadly separate generating plant into two categories based on their bid prices.
- 4.112 Due largely to their 'must run' characteristics, resulting from the subsidies they receive, their extremely low fuel costs or other technical characteristics (reflected in the bid price), areas where low carbon plant set the bid price were seen to have a deviation from the largely linear annual load factor vs. incremental constraint cost relationship, such that more than one linear relationship emerged.
- 4.113 Specifically, the low carbon observed (and expected) to have these levels of bid prices are hydro, wind, wave, tidal, nuclear and carbon capture and storage (CCS). All other generation plant types were considered to be non low carbon. Some Workgroup members believed that nuclear generators should not be included in the low carbon category due to the combination of (i) higher load factor of nuclear plant and (ii) very high bid prices of nuclear plant compared with, for example, onshore wind. Others believed that it should be included as its bid price characteristics were more similar to that of intermittent plant than conventional, non low carbon plant. The Workgroup agreed that further work was still required in this area with respect to the distinction between carbon and low carbon generation plant.
- 4.114 This divergence in the linear relationship between low carbon and non low carbon plant is illustrated in Figure 17 **Error! Reference source not found.**, below.



**Figure 17 – Divergence in the linear relationship between low carbon and non low carbon plant**

- 4.115 When considering the results from the analysis, the Workgroup agreed that the bid price of a generation plant was also one of the primary factors affecting the annual load factor vs. incremental constraint cost relationship. However, it can also be seen from the above graph, which is illustrative in nature, that similar bid price generation still demonstrate a linear relationship, albeit on a different slope.
- 4.116 Taking the combined effects of all of the above elements together and considering how the individual points on the graph are plotted results in the illustration in Figure 18, below.



**Figure 18 – Combined effect of price and load factor on constraint costs**

- 4.117 From the above the Workgroup appreciated that, for areas of the transmission system with sufficient generation plant diversity and a correlation of running and constraints fixed at that of the optimally invested transmission network level (i.e. at the point where incremental constraint costs are comparable to the incremental cost of capacity arising from the Transport model), the incremental transmission network cost (shown in red above) is set by the annual load factor of the incremental 1MW of generation (the volume element; shown in grey above) and the bid price of the marginal non low carbon plant (the price element; shown in green). The market bid/offer premium is assumed to be 0.6 and 1.6 times the short run marginal cost, which is the value used by the Proposer in the ELSI market model used to produce the generation annual load factor vs. incremental constraint cost graphs shared with the Workgroup.
- 4.118 Alternatively, for areas of the transmission system with insufficient generation plant diversity and a correlation of running and constraints fixed at that of the optimally invested transmission network level, the incremental transmission network cost (shown in purple above) diverges such that for low carbon plant it is set by the annual load factor of the incremental 1MW of generation (the volume element; shown in grey above) and the bid price of the low carbon plant, which includes a low carbon bid premium - LC (the price element; shown in green). In this instance the incremental transmission network cost for non low carbon plant continues to be set by the factors in the grey and red boxes, as before.
- 4.119 In both cases the maximum incremental cost was set by the incremental cost of the fictitious 100% annual load factor, non low carbon generation plant as this cost was equivalent to the long run marginal cost (i.e. transmission asset cost) arising from the existing ICRP Transport model calculation.
- 4.120 The Workgroup concluded that this divergence effect occurred where low carbon plant dominated a particular area of the transmission network, all be it that some members of the Workgroup disagreed with nuclear being included in the low carbon plant definition used here.
- 4.121 As a result of (i) a review of the Proposer's analysis done in the ELSI model, (ii) additional work undertaken by the Workgroup in another generic market model and (iii) a detailed review of the variables impacting on incremental constraint costs and the resultant impact on the annual load factor vs. annual incremental constraint cost relationship, all set out above, the Workgroup came up with a number of potential alternatives to address the issues highlighted by this work. The first step was to develop a method for practically taking account of diversity in the Transport and Tariff model.

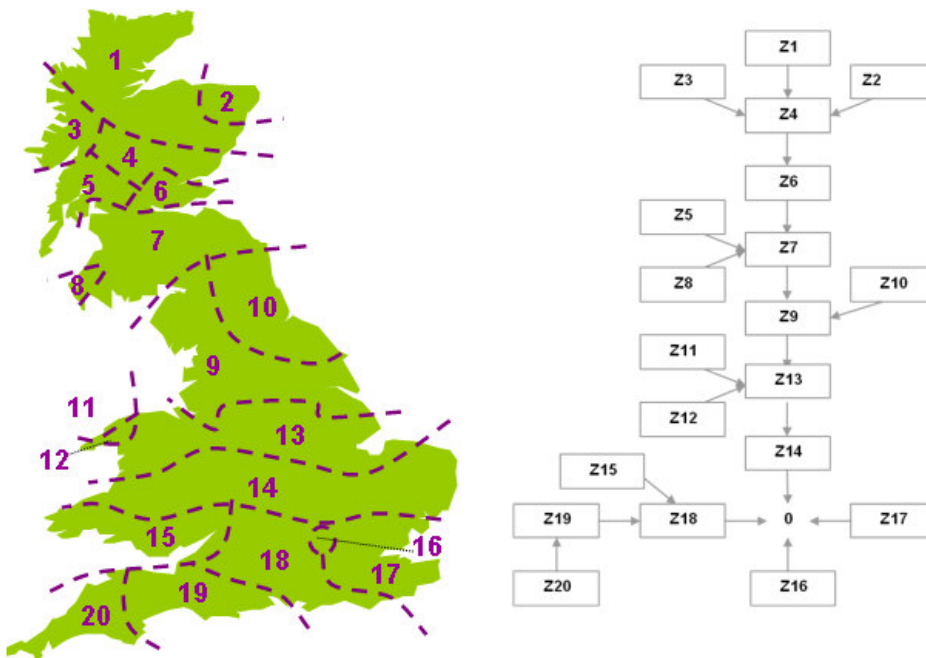
Practical methods for taking account of diversity in the Transport and Tariff model

- 4.122 The following section explores the approach developed by the Workgroup for incorporating an approach that some believe could better take account of generation plant diversity into the Transport and Tariff model.
- 4.123 Potential options and alternatives for addressing the issue of diversity all seek to identify, with increased granularity to the Original proposal, which of the wider incremental costs are shared and which are not shared based on the diversity of generation plant types in an area of the transmission system. As set out above, this is largely as a result of differences in bid and offer prices.
- 4.124 The first challenge is how the incremental costs can be split to provide the additional granularity required. To address this the Workgroup developed a method for calculating zonal boundary lengths utilising the expanded zonal incremental kilometres of transmission circuit routes arising from the Transport model and by defining a matrix of zonal transmission boundaries of influence (i.e. the path that an incremental MW would take, specifically which boundaries it would cross, to get to the notional centre of the transmission network).
- 4.125 First, the incremental kilometres are taken from the Transport model. For some potential alternatives the Year Round incremental kilometres are used, as those deemed to be shareable in the Original proposal. The Peak Security based incremental kilometres are not utilised. For other potential alternatives a single background may be used (i.e. the dual background approach, of Peak Security and Year Round, would not be utilised). An illustrative example of the Year Round incremental kilometres, taken from the Tariff model is shown in Figure 19, below.

Derivation of Zonal Generation Tariffs - Year Round				
Zone	Zone Name	Generation Charge Base: TEC Net Stn * ALF	Unadjusted Transport Zonal Wtd Marginal (km)	Unadjusted Transport Zonal Tariff (£/kW)
1	North Scotland	0.273	781.5	16.49
2	Peterhead	0.885	599.1	12.64
3	Western Highland & Skye	0.192	882.1	18.81
4	Central Highlands	0.201	679.7	14.34
5	Argyll	0.220	506.6	10.69
6	Stirlingshire	1.833	469.7	9.91
7	South Scotland	2.232	441.3	9.31
8	Auchencrosh	0.044	469.3	9.90
9	Humber & Lancashire	12.353	158.1	3.34
10	North East England	0.832	177.6	3.75
11	Anglesey	0.534	130.6	2.76
12	Dinorwig	0.493	95.4	2.01
13	South Yorks & North Wales	10.252	97.7	2.06
14	Midlands	5.042	41.4	0.87
15	South Wales & Gloucester	5.427	-132.7	-2.80
16	Central London	0.001	-308.2	-6.50
17	South East	9.421	88.9	1.88
18	Oxon & South Coast	0.346	-118.8	-2.51
19	Wessex	1.445	-231.9	-4.89
20	Peninsula	0.680	-350.1	-7.39

**Figure 19 – Illustrative Year Round Zonal Incremental km**

- 4.126 All potential options and alternatives for diversity utilise the fact that each of the zonal incremental kilometres (i.e. the Unadjusted Transport Zonal Wtd. Marginal km above) represents the incremental network requirements to the notional centre of the transmission network. Therefore, provided the path of the incremental 1 MW is known, one zonal incremental kilometre value can be subtracted from the other to calculate the transmission boundary length (i.e. distance from the demand weighted centre of one TNUoS zone to the next). This is done by establishing a zonal transmission boundaries of influence matrix for the TNUoS generation charging zones as represented diagrammatically in Figure 20, below.



**Figure 20 – Diagrammatic representation of zonal boundaries of influence**

4.127 The zonal transmission boundary length calculation, using the Year Round zonal incremental kilometres shown in Figure 21, for generation TNUoS zones 1 through 6 are shown in Figure 21, below.

Zone	Name	YR Incremental MWkm	Z1-Z4	Z2-Z4	Z3-Z4	Z4-Z6	Z5-Z7	Z6-Z7
1	North Scotland	781.53	1					
2	Peterhead	599.11		1				
3	Western Highland & Skye	882.10			1			
4	Central Highlands	679.74	-1	-1	-1	1		
5	Argyll	506.62					1	
6	Stirlingshire	469.68				-1		1
7	South Scotland	441.31					-1	-1
8	Auchencrosh	469.25						
9	Humber & Lancashire	158.11						
10	North East England	177.59						
11	Anglesey	130.61						
12	Dinorwig	95.37						
13	South Yorks & North Wales	97.65						
14	Midlands	41.39						
15	South Wales & Gloucester	-132.68						
16	Central London	-308.22						
17	South East	88.95						
18	Oxon & South Coast	-118.81						
19	Wessex	-231.88						
20	Peninsula	-350.14						
Incremental Boundary Length (400kV km)			101.80	-80.62	202.37	210.06	65.31	28.37
	Zone		1	2	3	4	5	6

**Figure 21 – Example of zonal transmission boundary length calculation**

4.128 Using the approach outlined above, zonal transmission boundary lengths can be calculated for each TNUoS charging zone (e.g. 781.53 – 679.74 = 101.79, for Zone 1 in Figure 21, above). Hence for any TNUoS charging zone, the path that the incremental 1 MW takes to the notional centre of the transmission network can be broken down into its component boundary lengths. Potential options and alternatives for dealing with issues of diversity developed by the Workgroup would utilise this to establish the proportion of total incremental kilometres that are shared.

4.129 The zonal transmission boundaries of influence is also required to map the route of the incremental 1 MW as illustrated, again for generation TNUoS zones 1 through 6, in Figure 22 below. For example, in this illustration, each of the transmission boundary lengths that are crossed by an incremental 1 MW of generation from TNUoS zone 6 (i.e. Z6 → Z7 → Z9 → Z13 → Z14) will add up to the total incremental kilometres for zone 6, 469.68, as shown above.

Zone	Name	YR Inc. Boundary Length	Z1	Z2	Z3	Z4	Z5	Z6
1	North Scotland	101.80	1					
2	Peterhead	-80.62		1				
3	Western Highland & Skye	202.37			1			
4	Central Highlands	210.06	1	1	1	1		
5	Argyll	65.31					1	
6	Stirlingshire	28.37	1	1	1	1		1
7	South Scotland	283.20	1	1	1	1	1	1
8	Auchencrosh	27.94						
9	Humber & Lancashire	60.46	1	1	1	1	1	1
10	North East England	19.48						
11	Anglesey	32.96						
12	Dinorwig	-2.28						
13	South Yorks & North Wales	56.27	1	1	1	1	1	1
14	Midlands	41.39	1	1	1	1	1	1
15	South Wales & Gloucester	-13.86						
16	Central London	-308.22						
17	South East	88.95						
18	Oxon & South Coast	-118.81						
19	Wessex	-113.06						
20	Peninsula	-118.26						
Incremental MWkm			781.53	599.11	882.10	679.74	506.62	469.68
Zone			1	2	3	4	5	6

**Figure 22 – Zonal transmission boundaries of influence to map the route of the incremental MW**

- 4.130 Finally, potential options and alternatives would compare the cumulative proportion of low carbon (LC) and carbon (C) generation TEC behind each of the transmission boundaries to determine if sufficient diversity exists behind the boundary for its previously calculated length to be shared. This is illustrated for TNUoS generation zone 1 in Figure 23 , below.
- 4.131 The reason a cumulative TEC value is used is that the underlying issue of diversity is one of sufficient low bid price generation plant (i.e. carbon plant; who would normally be willing to pay the System Operator for the avoided fuel cost of being bid off in the balancing mechanism) behind a transmission boundary.
- 4.132 The Workgroup noted that the exact groupings of carbon and low carbon plant were still being developed (based on bid/offer price characteristics) and that the numbers in Figure 23 were therefore only illustrative in nature to demonstrate the cumulative effect of TEC behind a boundary.

Name	Incremental Boundary (km)	Z1	Z1
		LC	C
1 North Scotland	101.80	256	468
2 Peterhead	-80.62		
3 Western Highland & Skye	202.37		
4 Central Highlands	210.06	566	2068
5 Argyll	65.31		
6 Stirlingshire	28.37	1577	4472
7 South Scotland	283.20	5958	5558
8 Auchencrosh	27.94		
9 Humber & Lancashire	60.46	10518	21978
10 North East England	19.48		
11 Anglesey	32.96		
12 Dinorwig	-2.28		
13 South Yorks & North Wales	56.27	12832	36687
14 Midlands	41.39	15443	41974
15 South Wales & Gloucester	-13.86		
16 Central London	-308.22		
17 South East	88.95		
18 Oxon & South Coast	-118.81		
19 Wessex	-113.06		
20 Peninsula	-118.26		

**Figure 23 – Cumulative LC and C generation TEC behind a boundary**

- 4.133 Various options and alternatives were considered by the Workgroup, utilising the method for incorporating into the Transport and Tariff model set out above.



**a) i) Plant type specific or ii) Zonal average diversity per TNUoS zone**

4.134 The Workgroup discussed the possibility of addressing the diversity issue through both plant specific and zonal average generation diversity per TNUoS charging zone. In doing so, three possible methods were devised, which are summarised in Table 3, below.

<b>Area</b>	<b>Original</b> All wider Year Round (YR) shared	<b>Method 1</b> YR zonal shared / not shared split	<b>Method 2</b> YR zonal shared / not shared split	<b>Method 3</b> Single background with zonal sharing factor
Dual background	Yes	Yes	Yes	No
Wider locational tariff components	2	3	3	1
MITS sharing	All YR incremental costs	YR split into shared / not shared	YR split into shared / not shared	All incremental costs with zonal sharing factors
Application of generator specific sharing factor	Yes	Yes; to shared element	Yes; to shared element	No
Diversity calculation	None	Based on deterministic relationship between low carbon / carbon ratio	Based on minimum of low carbon / carbon generation in an area	Based on minimum of low carbon / carbon generation in an area
Method for split of Incremental Costs	None	Zonal boundary length using transmission boundaries of influence	Zonal boundary length using transmission boundaries of influence	Zonal boundary length using transmission boundaries of influence

**Table 3 – Options considered for addressing generation plant type diversity issues**

*Method 1 – Year Round shared/not shared split based on low carbon / carbon generation ratio*

4.135 The approach of Method 1 is to build upon the existing market modelling undertaken in ELSI which some Workgroup members agreed demonstrated that a relationship between the annual load factor of an individual generating plant and its impact on incremental transmission network costs exists, and the subsequent investigation by the Workgroup concluding that in areas of the transmission network with insufficient diversity of generation plant, the high bid prices of low carbon generators leads to a divergence of this relationship as set out in paragraphs 4.101 through to 4.121 The aforementioned divergence is consistent with the ELSI based analysis undertaken by the Proposer that demonstrated a deterioration of the generation annual load factor vs. incremental constraint cost relationship in the long term in areas of the transmission system with insufficient diversity of generation plant. A snapshot of this analysis shared with the Workgroup is shown in Figure 21 below. These graphs show that in SYS Zone 1 the relationship breaks down as large proportions of low carbon generators are assumed to connect by 2020 (using NGET's Gone Green scenario), but that in SYS Zone 6 the relationship remains reasonably robust due to the diversity of plant behind the relevant transmission boundary.



**Figure 24 – Long term deterioration of the Load Factor vs. Incremental Constraint Cost relationship**

4.136 Ultimately, Method 1 recognises the importance of two key factors contributing to incremental transmission network costs:

- Generation annual load factor – as in the Original proposal; and
- Diversity of low carbon and non low carbon generation plant in an area of the transmission system.

4.137 Whilst annual load factor is generation plant specific, the diversity element is related to the zonal availability of sufficient non low carbon plant (or simply – Carbon plant) in a TNUoS zone (i.e. plant with a near marginal bid price). As the Workgroup were minded not to look for a complex solution based on bid price, Method 1 would utilise the ratio of cumulative low carbon (LC) to carbon (C) generation TEC behind a zonal transmission boundary as set out in paragraph 4.130 to establish what proportion of the associated incremental kilometres making up the transmission boundary length were shared or not shared.

4.138 This led to an approach that can be summarised as follows:

- 1) Calculate expanded zonal transmission incremental kilometres using both the Peak Security (PS) and Year Round (YR) backgrounds and the apportioning method proposed in the Original;
- 2) Derive the zonal transmission boundaries of influence and boundary length calculations using the YR background as set out above in paragraphs 4.126 to 4.129;
- 3) Split generation TEC in each generation TNUoS zone into carbon (C) and low carbon (LC) and calculate cumulative proportions of C and LC TEC from each TNUoS zone to the centre of the transmission network using the zonal transmission boundaries of influence;
- 4) Based on the result of analysis undertaken prior to finalising this potential alternative, compare the (C TEC)/(Total TEC) and (LC TEC)/(Total TEC) for each transmission boundary the incremental 1 MW of generation crosses with a predefined deterministic relationship (still being considered by the Workgroup, that would applies transmission network wide);
- 5) Using this predefined deterministic relationship, determine what proportion of each transmission boundary length is shared and what proportion is not shared. The Workgroup also considered that a potential alternative involving specific analysis of counter correlation of generation running behind a transmission boundary could be used at this point.
- 6) Total shared incremental kilometres form a separate shared YR tariff element and total not shared incremental kilometres form a separate not shared YR tariff element; and
- 7) Results in a four part wider TNUoS tariff using Annual Load Factor (ALF) as follows:

$$\begin{aligned}
 & (\text{PS} \times \text{TEC}) + (\text{YR}_{\text{not shared}} \times \text{TEC}) + (\text{YR}_{\text{shared}} \times \text{ALF} \times \text{TEC}) + \\
 & \quad (\text{Residual} \times \text{TEC})
 \end{aligned}$$



Where; YR<sub>not shared</sub> and YR<sub>shared</sub> are calculated using the pre-defined range of low carbon and carbon generation capacity ratios behind transmission boundaries, transmission boundary lengths and the transmission boundaries of influence defined above.

- 8) Intermittent plant *not exposed* to PS element on the basis that they are not modelled in this background for transmission network planning, but do contribute to the peak element inherent in YR.

4.139 The Workgroup noted that further consideration was required with respect to which generation plant types are included / excluded from the low carbon and non low carbon definitions that were proposed to be used and that this could result in a variation to any of the methods for addressing diversity developed by the group.

4.140 In addition the Workgroup noted that further analysis was required to determine how much sharing of transmission capacity occurs for different proportions of carbon and low carbon generation, as indicated in point 4 above and how specific analysis of counter correlation of generation plant running of all types could be included, as indicated in point 5, above.

Method 2 – Year Round shared/not shared split based on percentage minimum of low carbon or carbon generation to total

4.141 Some Workgroup members believed that maximum sharing occurs when a TNUoS zone contains an equal capacity of both low carbon and carbon generation and that the optimum transmission boundary capacity would be 50% of the combined capacities in this case. In practice perfect generation sharing would not occur and at times some constraint action (i.e. re-dispatch of generation at an additional cost) would be required. In these circumstances a slightly higher volume of thermal plant to low carbon would reduce incremental costs.

4.142 Method 2 builds on the premise set out above and defines the maximum amount of generation sharing that can occur on a transmission boundary as the percentage minimum of carbon or low carbon generation to the total generation behind a boundary, thereby limiting the total shared incremental kilometres to a maximum of 50%. Method 2 also uses cumulative low carbon (LC) to carbon (C) generation TEC behind a transmission boundary for this calculation as set out in Method 1, above.

4.143 Some Workgroup members did not follow the logic of why sharing would be limited to 50% of the transmission boundary length for this method. These members considered that sharable capacity could exceed 50% where an area had equal proportions of carbon and low carbon plant.

4.144 Development of method 2 led to an approach that can be summarised as follows:

- 1) Calculate expanded zonal incremental kilometres using both the Peak Security (PS) and Year Round (YR) backgrounds and the apportioning method proposed in the Original;
- 2) Derive the zonal transmission boundaries of influence and boundary length calculations using the YR background as set out above in paragraphs 4.126 to 4.129;
- 3) Split generation TEC in each generation TNUoS zone into carbon (C) and low carbon (LC) and calculate cumulative proportions of C and LC TEC from each TNUoS charging zone to the centre of the transmission network using the zonal transmission boundaries of influence;

- 4) Calculate the total shared incremental kilometres per transmission boundary based on percentage of minimum of C TEC and LC TEC to total TEC behind a transmission boundary;
- 5) Total shared incremental kilometres form a separate shared YR tariff element and total not shared incremental kilometres form a separate not shared YR tariff element; and
- 6) Results in a four part wider TNUoS tariff using Annual Load Factor (ALF) as follows:
 
$$(PS \times TEC) + (YR_{\text{not shared}} \times TEC) + (YR_{\text{shared}} \times ALF \times TEC) + (Residual \times TEC)$$
- 7) Intermittent plant *not exposed* to PS element on the basis that they are not modelled in this background for transmission network planning, but do contribute to the peak element inherent in YR.

Method 3 – Single background shared/not shared split based on percentage minimum of low carbon or carbon generation to total

- 4.145 Some members in the Workgroup were of the view that the approach used to incorporate recent changes to the NETS SQSS by splitting the TNUoS tariff into Peak Security and Year Round elements is overly complex and were unsure if the resulting separate incremental constraint cost signals are meaningful.
- 4.146 Some members also believed that the relationship between generation annual load factor and incremental constraint costs was not a robust one, and that generation annual load factor was not a significant factor in determining impact on incremental constraint costs.
- 4.147 Method 3 therefore proposes to do away with both the dual background (Peak Security and Year Round) approach and the use of a sharing factor based on generation annual load factor. It also uses the premise set out in Method 2 that a maximum of 50% of transmission network capacity can be shared on any transmission boundary.
- 4.148 This led to an approach that can be summarised as follows:
- 1) Calculate expanded zonal incremental kilometres using a single background with generation scaling factors similar to the Year Round (YR) background proposed in the Original.
  - 2) Derive the zonal transmission boundaries of influence and boundary length calculations using the YR background as set out above in paragraphs 4.126 – 4.129;
  - 3) Split generation TEC in each generation TNUoS zone into carbon (C) and low carbon (LC) and calculate cumulative proportions of C and LC TEC from each TNUoS charging zone to the centre of the transmission network using the zonal transmission boundaries of influence;
  - 4) Calculate the total shared incremental kilometres per boundary based on percentage of minimum of C TEC and LC TEC to total TEC behind a boundary;
  - 5) i.e.  $\text{Min} [C \text{ TEC} / \text{Total TEC}, LC \text{ TEC} / \text{Total TEC}]$ ;
  - 6) Zonal shared incremental kilometres as a percentage of total incremental kilometres forms the zonal sharing factor (ZSF) applied to the wider tariff for that TNUoS charging zone; and.
  - 7) Results in a two part wider TNUoS tariff as follows:
 
$$(YR \times ZSF \times TEC) + (Residual \times TEC)$$

**a) iii) Different treatment for positive and negative zones**

4.149 In a minor change to one of the above potential alternatives, this approach would treat positive and negative TNUoS zones in a different manner when calculating charges.

4.150 The Workgroup discussed the current proposed treatment of TNUoS under the Original proposal in negative tariff zones. Some members of the Workgroup considered that the application of a generation sharing factor to the Year Round element of the TNUoS tariff is less cost reflective than the baseline for negative zones and as a result improvements could be made to the proposed approach.

4.151 The Original proposal would calculate TNUoS tariffs in both positive and negative TNUoS zones for conventional power stations as follows:

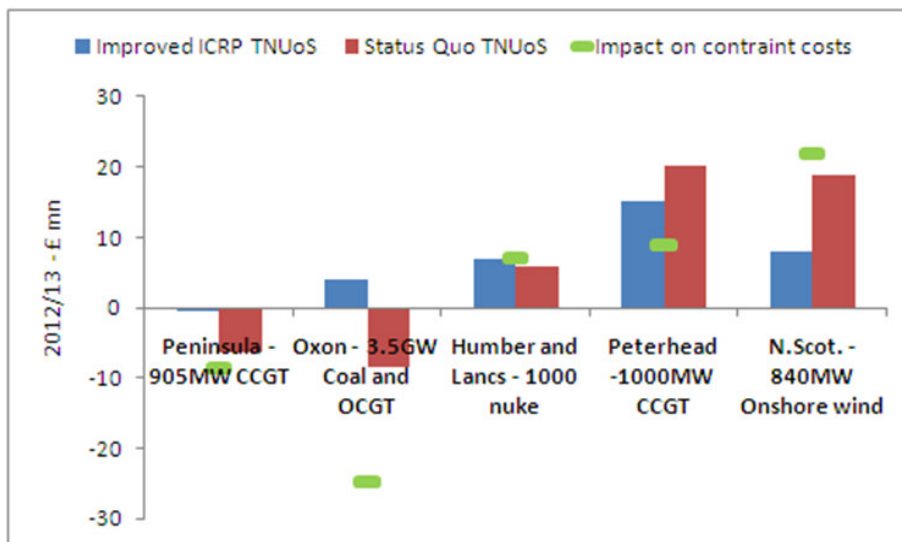
$$\text{Peak Security } \text{£/kW} + (\text{Year Round } \text{£/kW} \times \text{ALF}) + \text{Residual } \text{£/kW}$$

4.152 The Proposer considered that the application of a generator's annual load factor (ALF) to the Year Round element of the TNUoS tariff would make charging more cost reflective, taking into account the impact that an individual generating plant has on incremental transmission network costs.

4.153 Some Workgroup members considered that the effect of the Original proposal on TNUoS tariffs is to close the geographic differentials, meaning that in negative zones, generators' TNUoS credit is significantly lower than is currently the case and the generators' TNUoS charges paid in positive zones are lower. Some Workgroup members considered this to be more cost reflective than the existing ICRP approach and thus an improvement on the 'baseline'; other Workgroup members disagreed.

4.154 Some Workgroup members believed that the effects highlighted above are correct only if the current TNUoS signal in negative zones is inaccurate; i.e. if it is over rewarding these power stations in negative zones and more generally in the southern part of the GB transmission system.

4.155 These members undertook some initial analysis within the ELSI model that calculated the impact on annual constraint costs of removing generation from the network, in order to test this. The results of this analysis, shown in Figure 25 below, compare annual TNUoS charges under the Original proposal ("Improved ICRP") and the existing methodology ("Status Quo") against the impact of removing the associated capacity of generation in the areas investigated.



**Figure 25 – Comparison of TNUoS charges and impact on constraint costs (2012/13)**

- 4.156 The Workgroup debated the analysis presented and considered the example of Centrica’s Langage CCGT power station (“Peninsula” in Figure 25). Some Workgroup members indicated that, under one scenario modelled, the analysis showed that removing Langage from the background of the model resulted in a system-wide increase in constraint costs of £9m per annum. This was believed by these members to be closer to the current TNUoS credit of £5m per annum than the approximate £1m per annum TNUoS credit calculated by them using the Original proposal.
- 4.157 Some Workgroup members believed that, notwithstanding the fact that constraint cost savings should not necessarily equate to the same as the TNUoS payment, the change in the locational signal under the Original appears, at least in regions with low diversity, to be less cost reflective than the baseline (i.e. the existing methodology – “Status Quo” in Figure 25).
- 4.158 As a result of this analysis these Workgroup members considered that the Original proposal needs to be altered to make it more cost reflective in negative generation TNUoS zones and all TNUoS zones where there is little diversity of generation plant type.
- 4.159 Some members of the Workgroup questioned the input assumptions used to undertake the analysis set out above, and whether these assumptions were consistent with the underlying assumptions of the Original proposal. In particular, the assumptions used on transmission network boundary capacity were deemed important by some as the Original proposal is based on an optimally invested network, which would have a significant impact on constraint costs. Nevertheless, the Workgroup agreed that more work was required in this area.
- 4.160 Some in the Workgroup believed that suitable potential alternatives could include, but would not be limited to: (i) Applying TEC to the Year Round element of the TNUoS tariff rather than a generator specific sharing factor (based on a generator’s annual load factor); and / or (ii) Applying a diversity factor.
- 4.161 The majority of the Workgroup agreed that applying TEC to the Year Round element of the TNUoS tariff did not address the defect identified in the Original proposal and the Authority’s Direction; i.e. that TNUoS tariffs should reflect the differential impact of generation plant with different characteristics on incremental constraint costs.

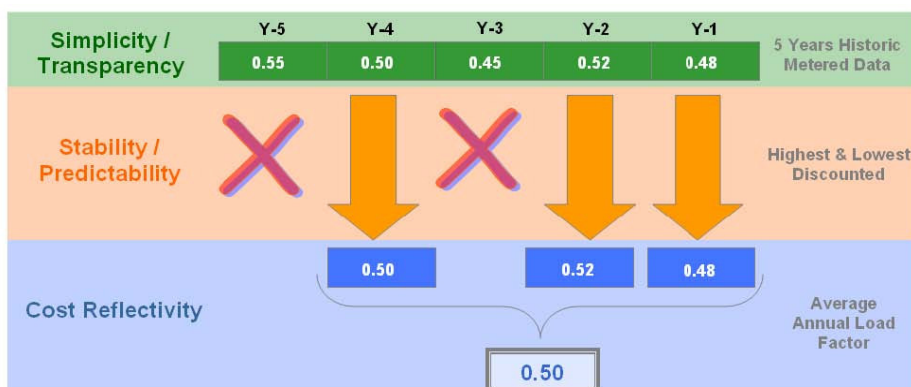
4.162 Potential options and alternatives taking account of diversity are discussed above.

**Q1: Do you believe that the Workgroup has fully considered the range of options for addressing how charging structures should be applied geographically to areas dominated by one type of generation, including on local circuits? If not, what other options would you like the Workgroup to consider and why?**

**b) Alternative approaches to ALF for reflecting user characteristics into charging**

4.163 The Original proposal is for the Year Round element of the TNUoS tariff to be scaled by a generator specific sharing factor, based on the annual load factor (ALF) of the generator. This is to better reflect the impact that generators with different plant characteristics have on the incremental cost of transmission network capacity than is possible under the current approach. The purpose of this cost reflectivity is to allow individual generators to take the cost of transmission into account when making decisions about where to locate and when to close their plant.

4.164 The Original proposed approach is to calculate this generator specific Annual Load Factor (ALF) by using the last 5 years' load factors for the individual power station concerned and calculate an average of the middle three values (i.e. ignore the highest and lowest values) as a proxy for the implicit assumptions made when planning investment in transmission network capacity. This is illustrated in Figure 26, below.



**Figure 26 – Calculation of ALF in the Original**

4.165 The Workgroup discussed the benefits and drawbacks of the Original proposal in the context of the defect that CMP213 modification seeks to address, and developed a range of potential alternative options.

Relevant Background to Original Proposal

4.166 Under the Original proposal TNUoS remains a signal of long run (i.e. transmission network investment) costs. Network investment decisions are ostensibly driven by the Transmission License requirement on transmission companies to plan in accordance with the National Electricity Transmission System Security and Quality of Supply Standards (NETS SQSS) and an established link between the NETS SQSS and TNUoS exists within the charging methodology set out in section 14 of the CUSC.

4.167 The Transport model is and will, under the Original proposal, continue to be used to calculate the long run incremental cost at a given connection point on the transmission network. The proposed dual background approach, using both a Peak Security and Year Round background, ensures that this calculation remains consistent with updates to the NETS SQSS and thus maintains the link within the charging methodology.

- 4.168 It is proposed, in the Original, that locational incremental requirements on a transmission circuit route are allocated to one background or the other based on that leading to the maximum flows on that transmission circuit.
- 4.169 The scaling factors derived in the new NETS SQSS (under GSR-009) and used in the aforementioned two backgrounds were done on the basis of achieving transmission network boundary flows that result in a level of transmission network investment consistent with the outcome of a full blown cost benefit analysis (CBA). It is for this reason that these factors are valid for planning transmission network investment and for use in the Peak Security and Year Round backgrounds when calculating long run network costs in the Transport model.
- 4.170 Nevertheless, this very approach to calculating the NETS SQSS scaling factors is what potentially makes them inappropriate for calculating an individual generator's contribution to the need for this transmission investment. This is why it is necessary to go back to the original CBA approach upon which the background scaling factors are based, for it is only here that it is possible to investigate an individual generator's contribution to the need for transmission investment to the level of granularity required for cost reflective TNUoS charges (that are non-discriminatory in nature).
- 4.171 Ideally, when running the CBA resulting in the scaling factors, which in turn will lead to a certain level of transmission network investment, generators would tell the transmission company exactly what they were going to do over the 40 year transmission asset life and this would form an input into the CBA, allowing for the optimum investment and the ability to calculate charges on that basis.
- 4.172 However, some generating companies have made it clear during the Transmission Access Review (TAR) process that they cannot predict the future operation of their asset any better than a transmission company can. For thermal plant the limit was said to be beyond an approximately two year time horizon due to market variables such as fuel prices, CO<sub>2</sub> prices, etc. The Workgroup noted that this was not necessarily the case for individual generators with high upfront capital costs and low ongoing running costs. Nevertheless, some believed that the outcome of the TAR process was definitive.
- 4.173 Hence, as transmission access proposals with long term commitments from generators did not progress through the governance process to implementation, it is necessary for the transmission company to make assumptions about the characteristics of individual generators when undertaking their CBA. Some examples of these assumptions include the generating plant's capacity, efficiency, fuel prices, CO<sub>2</sub> prices, unavailability due to maintenance and faults, bid prices, offer prices, available subsidies, etc.
- 4.174 As outlined in the diversity section, above, it is clear that when the margin of generation capacity over and above peak demand is increasing, it would not be economic to build sufficient transmission capacity to accommodate the full output of all generators simultaneously.
- 4.175 Therefore, some implicit sharing by generation of network capacity does occur on the transmission network. The extent of this sharing is related to all the characteristics of individual generators outlined above, as assumed in the transmission network planning process.
- 4.176 In order to reflect transmission network sharing into the charging calculation for transmission network investment (i.e. long run) costs it is necessary to introduce a proxy for the assumptions made at the time of

planning transmission network capacity about a generating plant's characteristics.

- 4.177 Through the results of market modelling (using the ELSI modelling tool) some in the Workgroup believed that a generating plant's annual load factor (which is a result of all its characteristics relative to the rest of the market) is a better proxy for its incremental impact on transmission costs than its TEC (MW) capacity alone.
- 4.178 It is for this reason that the Original proposal uses a sharing scaling factor based on a generator's annual load factor as a proxy for the assumptions made at the time of planning the transmission investment, the cost of which the TNUoS tariff is attempting to reflect.
- 4.179 The Proposer took the view that, in order to remain consistent with the sharing proposal and not introduce any perverse incentives or unnecessary complexity and volatility the sharing scaling factor:

should	should not
<ul style="list-style-type: none"> <li>• in conjunction with TEC, contribute to the cost reflective signal, allowing generation plant to internalise the cost of transmission when making plant siting and closure decisions;</li> </ul>	<ul style="list-style-type: none"> <li>• affect the efficient despatch of the most economic generation plant (i.e. running decisions) in a given market period;</li> </ul>
<ul style="list-style-type: none"> <li>• reflect implicit assumptions made about generation plant characteristics when planning the transmission network;</li> </ul>	<ul style="list-style-type: none"> <li>• necessarily reflect actual, and potentially drastic, changes in generation plant characteristics in the short term;</li> </ul>
<ul style="list-style-type: none"> <li>• reflect the 'long-run' nature of investments in transmission network capacity and promote stability of TNUoS tariffs;</li> </ul>	<ul style="list-style-type: none"> <li>• undermine the important commitment to pay charges for a set period, aspect of TNUoS tariffs;</li> </ul>
<ul style="list-style-type: none"> <li>• remain consistent with the implicit and ex-ante nature of the sharing assumption (i.e. Users do not provide explicit information); and</li> </ul>	<ul style="list-style-type: none"> <li>• place additional burden on Users with the need to provide additional information as this was found to be too difficult under TAR; and</li> </ul>
<ul style="list-style-type: none"> <li>• be calculated in a simple, deterministic fashion to avoid the need for complex incentives and therefore promote simplicity and predictability of TNUoS tariffs.</li> </ul>	<ul style="list-style-type: none"> <li>• place additional burden on Users with the need to predict the actual characteristics of competitor's plant in order to forecast TNUoS tariffs.</li> </ul>

- 4.180 The Proposer and some in the Workgroup believed that the Original proposal for the calculation of ALF had the following benefits:
- It recognises that most transmission network capacity is planned as a trade off with future potential constraint costs in a manner consistent with the NETS SQSS by introducing both a Peak Security and a Year Round element to tariffs;
  - It utilises the relationship between generation annual load factor and constraint costs to calculate a simple proxy for the assumptions made when planning transmission network capacity;

- In doing so it takes into account the characteristics of a specific generating unit and its impact on the incremental cost of transmission network capacity, thereby increasing the cost reflectivity of TNUoS tariffs;
- By using the historic metered output of a generating unit to calculate an ex-ante annual load factor for the upcoming TNUoS year it maximises simplicity and transparency of commercial arrangements and the predictability of TNUoS tariffs for all Users;
- It minimises additional burden on transmission network Users by not requiring additional information from generators;
- An ex-ante approach does not undermine the commitment to pay TNUoS tariffs, for a fixed period, aspect of TNUoS (i.e. Users cannot avoid TNUoS simply by not running); and
- By using an average over a number of years and removing outliers it promotes stability of TNUoS tariffs and is more consistent with a cost reflective signal that is based on long-run incremental costs.

4.181 Others in the Workgroup believed that the Original proposal had the following disadvantages:

- It could be perceived as blurring the boundary between transmission (TNUoS) charges (to reflect and recover the long term costs of providing the transmission assets) and transmission system balancing (BSUoS) charges (to recover the cost of balancing the transmission system);
- It was not clear that the ALF approach is more cost reflective with the transmission system being developed in line with NETS SQSS (as amended by GSR009 which acts as a proxy for a full cost benefit analysis); and
- It could be perceived as backwards looking: a generator's past performance is not necessarily a good indication of its future use of the transmission network. For example, annual load factors for thermal generation will change depending on which fuel is in merit. In addition, annual load factors for such plants are expected to change as more wind generation connects to the transmission system. This could be an issue for generation seeing reduced annual load factors that would still be charged on a basis of higher usage in earlier years. The Workgroup also noted that the converse would be true for generation seeing increases in annual load factors.

4.182 The Workgroup also discussed the fact that the Original proposal would calculate ALF based on 5 years of historic data with the highest and lowest values removed and averaging the remaining three. As some in the Workgroup believed that the sharing scaling factor (i.e. ALF) should be representative of a generators actual load factor, analysis was undertaken comparing the difference between calculated ALF and actual load factor using historic data for individual generators. An ALF method based on the Original proposal, based on a simple 3 year average of historic and based on the load factor from the previous year were investigated.

4.183 The conclusion of this analysis, the detail of which is presented in Annex 12 – Annual Load Factor Under the Original, was that the differences between a 5 and 3 year calculation were extremely small, but also that the difference between each of these and the actual load factor compared to the difference when using a single preceding year was not discernable for all generators analysed. Whilst there was some variation when looking at individual plant types, the general conclusions still held. Therefore the



Workgroup did not investigate further the calculation of ALF using a different number of historic years.

4.184 Options and potential alternatives developed by the Workgroup to address the perceived disadvantages to the Original proposal range from making the ALF less specific, to making it more so. These are outlined in **Table 4** below.

Num.	ALF	Description	Updated when?
i	TEC (MW)	ALF=100%, same charging result as approach used currently in the TNUoS charging methodology	TEC register
ii	NETS SQSS generic	Generation plant load factors from GSR-009	NETS SQSS updates
iii	Other generic	Generic historical average per generation plant type	At each Transmission Price Control Review
iv	User forecast	Ex-ante annual forecast, provided by the User, with ex- post reconciliation	Annually
v	Hybrid	Original proposal with option for User to provide own forecast (as per (iv))	Annually

**Table 4 – Potential options and alternatives for ALF**

**b) i) TEC Only**

4.185 This potential alternative would simply avoid the application of a sharing factor in the TNUoS tariff calculation altogether. Whilst the two part Peak Security and Year Round tariff elements would remain, the final TNUoS charge under this approach would be almost identical to that under the current Status Quo approach used in the charging methodology.

4.186 The Workgroup believed that this option, in its uniform treatment of all generation plant by using their TEC (MW) capacity only, was inconsistent with the Authority’s SCR Direction and the Defect highlighted by the Proposer, in the Original proposal (see above and Annex 8 – Detail of Original Proposal), to better reflect the impact generators with different characteristics have on the cost of incremental transmission network capacity.

4.187 For this reason and the fact that the existing TNUoS charging approach would always remain an option if the Authority rejected the Original and any WACM(s), the TEC only option was discarded as a possible alternative by the Workgroup.

4.188 The Workgroup noted that the potential alternatives under consideration for the sharing aspect of the Original that take account of generation plant diversity and the potential for different treatment between positive and negative TNUoS zones, set out above, could include capacity (MW) based elements.

**b) ii) & iii) SQSS or Other Generic load factor**

4.189 Another potential alternative approach would be to use a generic annual load factor for all types of generating plant, potentially using (i) the background scaling factors set out in GSR-009 or (ii) the generic load

factors based on historic data put forward in the Original proposal for use when actual metered data is not available (e.g. for new generators).

4.190 Some in the Workgroup believed that this could provide advantages over the Original proposal in that it could be perceived as:

- More closely related to the transmission investment decisions in line with the NETS SQSS as amended by GSR-009 (noting that the Original proposal deemed this approach invalid due to the way in which NETS SQSS factors have been calculated with a focus on transmission boundary flows);
- More consistent with the long run nature of transmission network investment (i.e. the sunk cost of transmission investment does not change with the characteristics of generation plant over time). The Workgroup noted that the TNUoS signal was ostensibly a forward looking one;
- More stable avoiding year on year fluctuations caused by volatility in fuel prices, generator maintenance plans, etc.. Some in the Workgroup believed that the ALF calculation proposed in the Original would be sufficiently stable given that it is, in essence, a rolling average; and
- Removing an element of complexity and volatility making TNUoS charges more simple and predictable.

4.191 The drawback to this approach is that the generation technology categories may be too wide, potentially leading to significant variation within one technology category (for example, depending on where in the life cycle a gas plant is, or whether wind is onshore or offshore). It may be possible to develop more specific categories to address this. The Workgroup investigated historic bid and offer prices to see if more granular generic load factors could be developed in a non-discriminatory fashion.

4.192 Whilst the analysis did show discernable groupings for high level plant types (i.e. wind, nuclear, coal, CCGT), it was not deemed possible to distinguish with any increasing granularity to achieve more specific generation technology categories.

4.193 Analysis was also undertaken on the above potential alternatives to illustrate the effect of using generic generation annual load factors, in preference to specific generation annual load factors, on the cost reflectivity of the solution. Both the northern Scotland (Planning Zone T) and southern Scotland (Planning Zone S) regions of the transmission network were investigated and generator's annual load factor vs. incremental constraint cost graphs created for specific load factors (i.e. actual modelled LF), GSR-009 based load factors and generic historic load factors as outlined above.

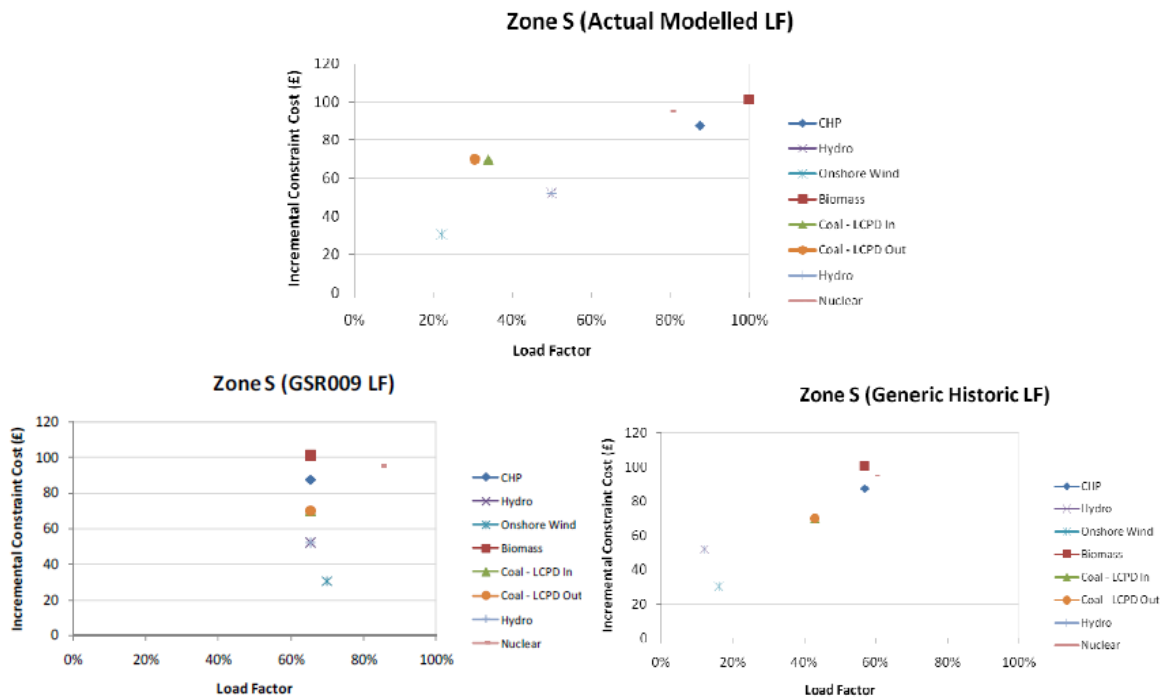


Figure 27 – Zone S; Use of generic factors in preference to specific actual

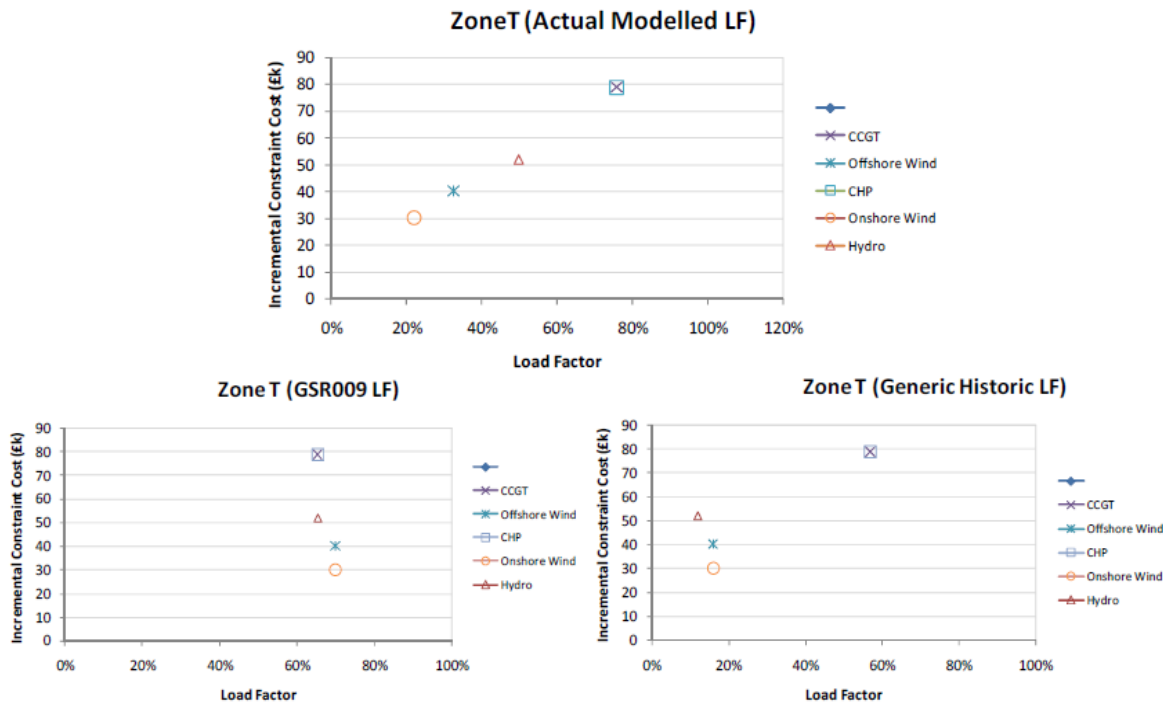


Figure 28 – Zone T; Use of generic factors in preference to specific actual

4.194 The results of the analysis undertaken for two areas of the transmission network (North of Scotland –‘T’ and South of Scotland –‘S’) illustrated in Figure 27 And Figure 28, above, show that the use of GSR-009 scaling load factors would not adequately distinguish between generating plant of different characteristics in a non-discriminatory manner.

4.195 Whilst the use of generic, historic, load factors by generation plant type is shown to be better than the GSR-009 scaling factors, it was noted by the Workgroup that increased granularity of plant type would be required in order to achieve something that was approaching the cost reflectivity of the annual load factor based approach proposed in the Original.

## More Specific Approaches

- 4.196 In order to more accurately reflect transmission system usage and sharing by generation, a more specific annual load factor approach has also been discussed by the Workgroup.
- 4.197 If a more specific approach was favoured, the Original proposal provides benefits compared to the generic load factor approaches discussed above. However, some Workgroup members felt that the Original proposal was not specific enough, and by reflecting historic rather than future use it cannot take account of situations where a generation plant is subject to a change in its role in the wholesale electricity market.
- 4.198 Others in the Workgroup were of the view that the TNUoS charging signal should not necessarily reflect sudden changes in the position of a generation plant in the wholesale electricity market,
- 4.199 The Workgroup discussed two high-level types of change in role:
- Periodic step changes:
- These changes may occur on a regular (e.g. change in season) or irregular (external influence) basis;
  - Regular changes are more likely to “average out” year to year, meaning the generator would only be subject to short-term gains and losses; and
  - Irregular changes are less likely to average out and could be unidirectional;
- One-off step changes:
- These changes will tend to have a unidirectional effect on a generation plant’s load factor that will not change in the foreseeable future;
  - The event may be predictable, such as the date that a new regulation comes into force or a fuel supply contract ends; and
  - It could also be unpredictable, such as a catastrophic generation plant failure.
- 4.200 The Workgroup discussed several different scenarios in more detail, which are all included in Annex 9 – ALF vs. Annual Incremental Cost Analysis. However there was not a consensus amongst the group as to whether the calculation of a sharing factor should closely match a change in role of a particular generator year on year.
- 4.201 Some Workgroup members noted that many of the scenarios discussed would currently have to be managed by generators under the existing charging approach, that generators would still have the option to increase or reduce their TEC for some permanent changes, and most importantly that many of changes considered would not be taken into account by the transmission network planner and hence would not have an immediately obvious impact on the incremental cost of capacity planned using cost benefit analysis techniques.
- 4.202 Others in the Workgroup were clear that they believed a more specific approach would be more cost reflective and potential alternatives were discussed in the group, as set out below.

### **b) iv) NGET and/or User forecast**

- 4.203 A potential alternative approach to the Original proposal would be to have a full forward looking forecast of generation plant load factor for the next (charging) year provided by each individual User (prior to the start of the charging year). This would give the generator an opportunity to signal, to

National Grid, what it intends to use (in the context of transmission network capacity), rather than being held to its past plant performance.

- 4.204 Some in the Workgroup believed that it would be logical to time the provision, by the User to NGET, of such a forecast with the timescales for notification of TEC reduction (i.e. 1 year and 5 days ahead of the TNUoS charging year in question) to remain consistent with the current length of commitment to pay TNUoS charges. Others believed that User forecasts could be provided in the November before the start of the (April) TNUoS charging year, before NGET publish draft TNUoS tariffs in December.
- 4.205 The disadvantage of this approach is that there would be an incentive for a generator to underestimate its forecast annual load factor, unless some form of incentive and ex-post reconciliation was included, in order to obtain a lower TNUoS charge. Full overrun charging, such as proposed in CAP162, might not be possible as it would be a locational constraint charge which could be interpreted as not allowable under the Transmission Licence (due to a restriction put in place at the time of Connect and Manage, not to target the impact of Connect and Manage locationally).
- 4.206 However, a simple incentive could be created such as charging a multiple of the TNUoS for any overrun over and above the forecasted annual load factor. For example, a generator could be charged twice its normal TNUoS rate for any overrun. An underestimate of its annual load factor by 10% would result in the generator paying 110% of the charge it would have paid had it estimated its load factor correctly. Thus, in a simple example, if a generator forecast an annual load factor of 50% and, as a result, it was due to pay £500k in TNUoS but ended up having an outturn annual load factor of 60% it would be charged £660k (£100k for the 10% extra plus £60k as the 10% additional charge / incentive).
- 4.207 In order to keep the incentive on the generator to estimate its annual load factor as accurately as possible, it would not seem appropriate to allow refunds for any over estimates (by the generator). Otherwise, the generator could play safe and estimate as high a load factor as it could (100%) and receive a refund to reflect the actual value. Any over recovery of allowable revenue made because of these charges could be rolled over to offset against the allowable revenue to be recovered in for the next TNUoS charging year. For negative TNUoS zones the incentive might be to overestimate the annual load factor so as to expose the generator to a higher negative TNUoS charge.
- 4.208 The possible arbitrary nature of a 'doubling' factor and concerns about the potential that any overrun charge could be considered as penal were noted. However, some members believed these factors already exist in other areas of the charging methodology and that further work could be done to balance the incentive provided and the cost reflectivity. It was suggested that any bandwidth / margin developed on an estimate would itself involve an incentive to under / over forecast.

#### **b) v) Hybrid Approach**

- 4.209 Both the Original proposal and the User forecast options set out in the preceding section provide more specific estimates of a generator's annual load factor. As discussed above, both options have benefits and drawbacks. A potential hybrid option would allow each generator to decide (on an annual basis; possibly with a year and 5 days notice or the November prior to the start of the charging year in April) whether to accept National Grid's annual load factor forecast for its plant (the Original proposal) or whether to submit its own forecast of its forecast annual load factor.

- 4.210 This would allow generation plant that do not expect a change in running hours (for example low-carbon generation) to benefit from the simplicity and stability of the Original proposal, and avoid exposure to an ex-post reconciliation process. At the same time it would allow those generators who are expecting their annual load factors to significantly change from historic performance (for example thermal generators expecting a reduction in load factor due to increased intermittent generation on the transmission system, or a plant planning a long outage for maintenance) to signal this and avoid being, what some in the Workgroup believed was, overcharged for transmission network capacity it will not use.
- 4.211 Other Workgroup members believed that the ALF calculation in the Original proposal would be more cost reflective of the long-run nature of transmission investment and the kind of assumptions made by transmission planners when undertaking cost benefit analysis for investments in transmission capacity. Consequently, these members did not believe that the averaging effect of the ALF was overcharging for transmission network capacity and that it was more reflective of incremental costs than both the existing capacity based (i.e. TEC only) approach and a more specific factor that changed year on year.
- 4.212 The Workgroup considered two possible downsides of the Hybrid approach:
- Generators would likely only self-report changes to their annual load factors that are in a favourable direction; i.e. reductions in load factors in positive charging zones and increases in negative charging zones; and
  - The ability of generators to significantly reduce TNUoS tariffs ahead of their plant closure: it would be possible for a generator to declare a 0% annual load factor to remove the Year Round element from its TNUoS charge (it would still be charged for Peak and Residual – unless it is intermittent in which case it is only the Residual, so it would not be possible to receive a ‘payment holiday’ by declaring a 0% ALF). Nevertheless, given the relative size of the Year Round element of TNUoS charges in some areas of the transmission network, such an approach could have a significant effect on the commitment aspect of TNUoS (i.e. the requirement to provide a year and five days notice or TEC reduction to avoid an annual commitment to pay TNUoS) in these areas.

#### **b) vi) Alternative Measures for ALF**

- 4.213 The Original proposal provides for calculation of a sharing factor, annual load factors – ALFs, based on the 5 years historic output of each individual generation plant. Currently the ALF would be calculated based on each power station’s metered output (MWh) and TEC (MW).
- 4.214 The Proposer confirmed that NGET would calculate each generators’ ALFs no more frequently than on an annual basis (in the absence of any extraordinary circumstances) to have effect throughout the following charging year.
- 4.215 For the potential alternatives pertaining to the inclusion of a generator ALF in the TNUoS charge calculation, the Workgroup also considered the following alternative different data sources to metered output in calculating ALF:
- Use of Final Physical Notification (FPN) as an alternative to metered output; or

- Forward looking Grid Code data items that could be used to provide a forecast output slant on the ALF calculation.
- 4.216 The potential for a better approach to calculating historical ALFs was discussed by the Workgroup during their fourth meeting. The debate focused on whether a historical generator ALF should be based on metered output or historical FPNs (PN at Gate Closure). The key points of the discussion were:
- Metered output is wholly reflective of actual generator output and it is simple to source and collate. However, it could be “distorted” by System Operator action in the balance mechanism (e.g. BOAs, constraint management contract instructions, etc.); and
  - FPNs are a forecast and therefore may differ from actual output (and therefore use of the transmission system). However, FPNs are a statement of commercial intent by the generator; i.e. leaving aside the constraints or needs of the System Operator, the FPN represents the extent to which a generator would use the transmission system during a particular settlement period.
- 4.217 Workgroup members questioned what ALF was intended to, or should represent. Should ALF be a reflection of a generator’s actual export to the transmission system or should it be an expression of the extent to which a generator would use the transmission system but for the limitations that the System Operator may impose on that generator?
- 4.218 The Workgroup believed that it could be argued that use of metered output would suppress ALFs for generators connected behind transmission constraints, where generation was curtailed due to network limitations. Calculating ALFs in a way that reduces TNUoS costs, relative to those TNUoS costs that would arise through use of an ALF based on FPN, to generators that are also considered to be particularly associated with constraint costs may be perceived as being not in the best interest of effective competition in generation.
- 4.219 However, during the discussions in Workgroup meeting 4, the possibility of a generator that is not connected behind a transmission network constraint intentionally withholding (MW) capacity with a view to deploying that capacity in the Balancing Mechanism (BM) marketplace was also considered. In such circumstances, an ALF based on a generators’ FPN may be considered to artificially suppress the TNUoS costs of that generator.
- 4.220 In considering the best approach on balance, the Workgroup returned to the discussion of why ALFs were being proposed in the first place. The ALF is proposed as an approach to adjusting TNUoS charges in order to reflect the differential impact on incremental transmission network costs of different generation plant types, a feature driven by the Authority’s Direction to better take account of *“the economic trade-off each Transmission Owner makes between expected constraint costs and the cost of new transmission reinforcements”*. If the driver for the ALF is to more effectively target transmission investment signals channelled through constraint costs it would seem counterintuitive to then ignore the effect of constraints upon the ALF.
- 4.221 Ultimately most Workgroup members agreed that there are potential flaws associated with both the Metered Output and FPN approaches to determining the ALF. However, the Workgroup noted that a calculation based on actual Metered Output would appear to deliver an ALF more aligned with the aims of the Project TransmiT SCR and the Defect identified by the Proposer (in CMP213) than an ALF based on FPN.

- 4.222 In addition to the above, the Workgroup also considered the possibility of using other forward looking data that may be available through the commercial framework.
- 4.223 The Workgroup felt that the ALF calculation approach set out in the Original proposal was blind to any forecast operating information that may be available from the generator and which may give a useful indication of a generator's plans to deviate from the "routine" operating pattern indicated by the 5 year historical average based approach for determining the ALF. Such information may be particularly relevant to generating plant that can contemplate base load or flexing operation.
- 4.224 The Workgroup noted that ideally no additional information would be requested from generators.
- 4.225 There the following forward looking Grid Code data items already provided by generators to NGET were considered by the Workgroup as potentially being appropriate for inclusion in an ALF calculation approach:
- BC1 - Pre-Gate Closure*
- PNs (and FPNs) – duty to provide PNs at 11:00am of the day prior to the trading day.
  - Maximum Export Limits (MEL)
  - Bid offer data (including dynamic parameters, QPNs etc.)
- OC2 – Outage Planning*
- OC2 Data – Outage planning up to 5 years ahead of real time.
- Planning Code Data*
- Output Data – Specifically, Output Data submitted annually by generators under PCA3.2.
- 4.226 The Workgroup discussed the fact that BC1 data is a short term view of likely generation plant operation. BC1 data is typically submitted or updated so close to real time as to be irrelevant for the purposes of a calculation that is conducted annually and which seeks to provide a medium to long term indication of ALF.
- 4.227 Planning Code Output Data (taking account of OC2 data), on the face of it, was considered to convey a generator's forecast operating patterns which would seem likely to be of interest to NGET in establishing a generator's forecast take up of transmission system capacity. Whether this data can be incorporated into a "simple" ALF calculation approach was unclear (and the benefits of using this data relative to using a "User Forecast ALF", as proposed in the possible alternative above, is also unclear).
- 4.228 The Workgroup concluded that if a forward looking approach was desired, either in part (as a feature of a hybrid approach) or in full, a User Forecast ALF with appropriately weighted incentives (as outlined in the potential alternative described above), would seem a more efficient and effective approach relative to the use of forward looking Grid Code data.

**b) vii) Ex-ante or Ex-post**

- 4.229 As set out above, the Original proposal would derive a generator specific Year Round TNUoS tariff (utilising the zonal Year Round tariff and a generator specific ALF), which will be applied to all generators to better reflect their use of the transmission system and provide signals as to where to most efficiently locate new generation (and retire old generation).



- 4.230 A key element of this calculation will be the application of an ex-ante Annual Load Factor (ALF), based on an average of each generation plant's historic load factors (using running information from the previous 5 years, with the highest and lowest discarded).
- 4.231 The Workgroup considered that either an ex-ante or ex-post approach could be used to derive generator specific or generic ALFs. These are discussed in more detail below, along with the associated benefits and drawbacks.
- 4.232 An ex-ante ALF would be calculated using each generators' previous years' data (as in CMP213 Original), or forecast by either NGET or the generator and then applied at the start of the TNUoS charging year (1<sup>st</sup> April). It is assumed that under a "pure" ex-ante approach, there would no reconciliations or changes to ALF against the actual running of the particular generation plant during the charging year in question.
- 4.233 The Workgroup noted that using the historic data generation plant load factor (produced by NGET) or the forecast generation plant load factor (provided, in advance, by each generator) to derive forward-looking TNUoS charging signals through an ex-ante ALF could be argued to be more consistent with the ICRP principles that underpin TNUoS. It could provide a better proxy for transmission investment decisions that the Transmission Licensees make and that generators should consider in their own investment decisions.

#### Ex-ante

- 4.234 The ex-ante determination of ALF would provide generators with clarity of the ALF that is to be used to calculate their TNUoS charges for each charging year and is unlikely to overly influence operational decisions.
- 4.235 If an averaging approach (such as the 5 year one used in CMP213 Original) is adopted in the ex-ante ALF, the impact on generators operational behaviour is likely to be further limited, therefore maintaining the distinction in signals between TNUoS and BSUoS. The Workgroup believed that, if this benefit is realised, an ex-ante application of ALF could also result in more stable ALFs year-on-year. In addition, it could mitigate instances of generators reducing their annual load factors to achieve TNUoS "payment holidays".
- 4.236 The key drawback to the use of an ex-ante ALF is that it will not reflect known market and operational conditions that impact the running regimes of (particularly conventional) generation plant. In particular, it will not take account of:
- Known changes to the generation merit order arising from variations to fuel prices;
  - Long-term planned generation outages for large-scale maintenance/overhaul;
  - Mothballing of generation plant; and
  - Time limited generation running hours under LCPD and IED.
- 4.237 For example, current and forecast gas prices mean that many marginal gas generation plants are unlikely to run significantly (if at all) for the foreseeable future (2-3 years out). Ex-ante ALF calculations will not take account of these forecast changes to generation running regimes when setting TNUoS charges. If the premise of TNUoS charging is to remain forward looking and cost reflective, it could be argued that this effect may not be consistent with the underlying TNUoS charging principles.

4.238 Some Workgroup members argued that year on year changes to a generators running regime in the short-term would be unlikely affect incremental transmission network capacity requirements and that a historic averaging approach was therefore not inconsistent.

#### Ex-post

4.239 Under an ex-post approach, ALF would be calculated using data (for example metered output or bid/offer information) taken throughout a charging period and used to derive generation ALFs and resultant TNUoS charges that would be recovered at the end of that charging period. The Workgroup noted that the charging period referred to here is likely to be monthly / quarterly / seasonally rather than the 'traditional' single charging year (1<sup>st</sup> April to 31<sup>st</sup> March).

4.240 There are a number of approaches that could be used to calculate the ALF ex-post. They are all likely to produce ALFs that better reflect generation plants' running regimes over the charging period but would also be significantly more volatile as they would require either monthly/seasonal profiling or end of (charging) year reconciliations to ensure appropriate revenue recovery. Possible models could include:

- An ex-post rolling monthly ALF and charge; and
- An ex-post quarterly/season ALF and charge.

4.241 Some Workgroup members believed that an ex-post approach to setting generation ALF would invariably lead to a more accurate ALF that could be used in the derivation of TNUoS charges. In particular, it would better take account of factors that change the running regimes of (particularly conventional) generation.

4.242 However, the Workgroup noted a number of potential drawbacks to calculating ALFs on an ex-post basis. In particular is that it could begin to blur the distinction between the roles of BSUoS and TNUoS, in that it could become an operational signal rather than the intended locational signal of the cost of incremental transmission network capacity. Generators could start to factor in the ability to reduce their ALF in to their operational decisions, in order to benefit from reduced TNUoS charges.

4.243 Further, in being backward looking, ex-post ALFs would likely de-link TNUoS charges from the forward looking transmission investment decision making process upon which they are meant to be predicated. The Workgroup understood that Transmission Licensees do not make transmission infrastructure investments based on generators' historic running regimes; rather they are made using forecasts of future market conditions and associated generation annual load factors over a number of years.

4.244 Finally, the Workgroup believed that introducing ex-post elements to the TNUoS charge could result in significant TNUoS charging shocks for generators. Material changes to the load factors assumed for individual or classes of generators could result in large reconciliations being required during or at the end of each charging period, in order to ensure accurate revenue recovery. Whilst this could be mitigated to some extent through profiling or shorter charging periods, it would still result in TNUoS charges that could vary significantly over relatively short timescales. The risks associated with this potential volatility (in TNUoS charges) would then likely be factored into generator costs / operating decisions (leading to higher wholesale, and thus end consumer, prices).

4.245 Whilst some Workgroup members preferred an ex-post based approach, the majority supported an ex-ante approach to calculating the generator ALF for TNUoS charging purposes.

**Q2: Do you believe that the Workgroup has sufficiently reviewed all the necessary options on how a sharing factor (i.e. ALF) could be calculated. Are there any areas that you think may need further development? If so, please specify along with an associated justification.**

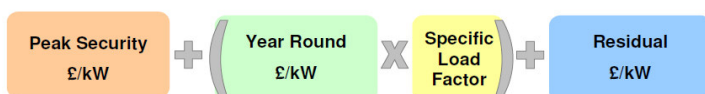
**c) Whether intermittent generation technology types should be exposed to the peak element of the tariffs**

4.246 The Original proposal would split the existing wider locational element of the TNUoS tariff into two elements, the Peak Security element and the Year Round element, consistent with the bifurcation of backgrounds in transmission planning introduced into the NETS SQSS through GSR-009.

4.247 In addition the Original proposal would levy the Year Round element on all generation plant types in proportion to their ALF (a generator specific load factor based %) and TEC (MW), whereas intermittent plant types would not be exposed to the Peak Security element on the basis that these plant are not considered present at times of peak demand when planning transmission network capacity at times of peak demand (i.e. the NETS SQSS does not plan capacity for intermittent generation at peak).

4.248 The resulting tariff structure is shown in Figure 29, below.

**Conventional Tariff =**



**Intermittent Tariff =**



**Figure 29 – Tariff structure in the Original Proposal**

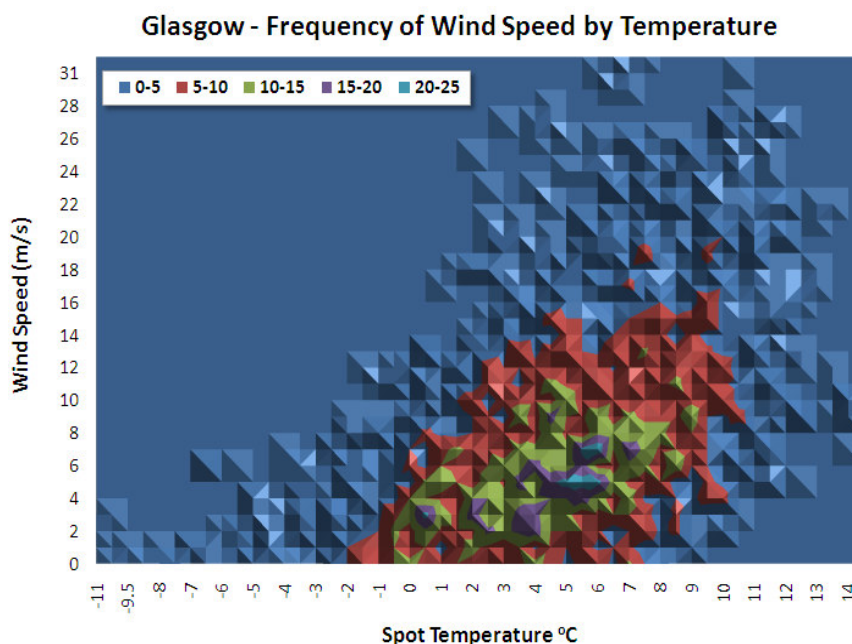
4.249 The Authority's SCR Direction specifically set out a consideration of whether intermittent generation technology types should be exposed to the Peak Security element of the TNUoS tariff. The Workgroup considered 2 possible changes to the Original that could be made:

- i) That intermittent plant were exposed to the Peak Security element to some extent; or
- ii) That intermittent plant exposure to the Peak Security element be index linked to an appropriate factor.

**c) i) Exposed to some extent**

4.250 A potential alternative approach could be where intermittent generation would be exposed to a proportion of the Peak Security element of the TNUoS tariff. The Workgroup began by considering both how often intermittent generation (predominately wind) would run over times of peak demand and how the NETS SQSS GSR-009 group came to their conclusion to scale wind to 0% when planning for demand security at peak.

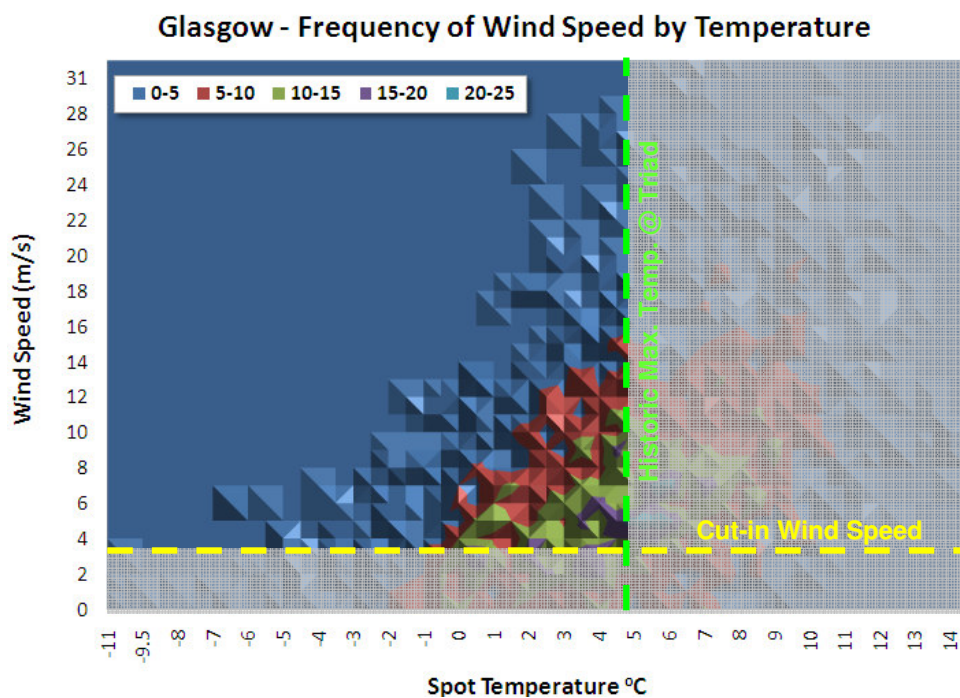
- 4.251 The Workgroup discussed the fact that the two main reasons why wind generation often has a low output over times of peak demand is that peak electricity demand in GB tends to occur during the coldest weather in a year and that these cold weather periods normally coincide with high pressure systems in which wind speeds are very low.
- 4.252 This is exacerbated by the fact that at very low wind speeds, there is insufficient torque exerted by the wind on the wind turbine blades to make them rotate. However, as the speed increases, the wind turbine will begin to rotate and generate electrical power. The speed at which the wind turbine first starts to rotate and generate power is called the cut-in speed and is typically between 3 and 4 metres per second (of wind at the hub height).
- 4.253 Use of historical weather data is often used as a means of estimating wind production. Actual wind farm production data is available, but is limited in extent. By way of illustration, both wind speed and temperature data was obtained from the Glasgow area for the years 2006 – 2012. This data, with an hour by hour granularity, was reduced to the months of November, December, January and February between the times of 16:00 and 19:00 (i.e. 3124 periods in total) on the basis that these are the times when peak electricity demand is most likely to occur.
- 4.254 The frequency of a given wind speed by temperature was subsequently plotted and is shown in Figure 30, below.



**Figure 30 – Glasgow Frequency of Wind Speed by temperature**

- 4.255 The above plot shows that the temperature during the aforementioned periods varied from -11 °C to 14.5 °C, whilst the wind speed varied from 0 m/s to 31 m/s. The plot also shows a clear relationship between temperature and wind speed, with the mean and deviation increasing with temperature. The dark blue areas represent an occurrence of wind speed at a given temperature of between 0 and 5 periods (i.e. between 0% and 0.2% of the sample set), the red indicates an occurrence of between 5 and 10 periods (i.e. between 0.2% and 0.3% of the sample set), etc.
- 4.256 Despite the fact that wind speeds have not been converted to those expected at hub height (i.e. speeds would normally be expected to be somewhat greater at hub height) a representative cut-in speed is overlaid along with a representation of the historic maximum temperature over the appropriate GB Triad periods in order to assist in visualising the proportion

of time wind generation that could have been at 0% output over times of peak electricity demand. This is shown below in Figure 31.



**Figure 31 – Glasgow Frequency of Wind Speed with Temperature w. Turbine cut in speed and representative max. historic temp.**

- 4.257 The Workgroup agreed that the above analysis is by no means conclusive for a number of reasons (including the simplifications highlighted). However, the Workgroup agreed that it does corroborate the notion that wind generation output over times of peak electricity demand (i.e. the time at which the transmission network is planned for demand security) is more likely to be less than at times of lower electricity demand, when the temperature is higher. The GSR-009 NETS SQSS modification group came to a similar conclusion using a different and much more substantial data set.
- 4.258 It was noted that the GSR-009 consultation stated, “A scaling factor of 0% for intermittent generation is simplest to articulate and implement, but analysis of the wind data supports the inclusion of wind generation at 5% of Registered Capacity. This is because, against the dataset used, the GB 2020 wind fleet will be at 0-2% total output for an average of only 4 hours per year; whereas it will be at 2-7% output for an average of 160 hours per year. The working group’s view is that there will be limited practical difference if a factor of 0% is used (especially given the scale of most transmission reinforcements), but requests industry views on the proposed 5% level at which to include intermittent generation in a demand security assessment. Wind generation is expected to account for the vast majority of Great Britain’s intermittent generation for the foreseeable future.”
- 4.259 On the basis of the above, the Workgroup considered the possibility of intermittent being exposed to the proposed Peak Security element of the TNUoS tariff. It was considered that this contribution may be justified somewhere around 5% (from the GSR-009 conclusions) or above, but that it likely be much less than 100% given the proportion of the year that wind generators are at this level of output as illustrated above in Figure 7.
- 4.260 Some Workgroup members noted that one difficulty with this approach would be the justification for this exposure to the Peak Security element. Despite actual historic wind output over times of peak demand, the deterministic standards against which transmission network capacity for demand security reasons is planned currently dictates that wind generation



has no influence on the incremental need for transmission network capacity at times of peak electricity demand.

- 4.261 A potential alternative considered would be to update TNUoS charging as and when the NETS SQSS plans for intermittent generation to be present at peak conditions (see below).

**c) ii) Index linked to something**

- 4.262 The Workgroup considered whether the exposure of intermittent generation plant to the Peak Security element of the TNUoS tariff could be index linked to something and agreed that the most appropriate linking would be directly with the NETS SQSS.
- 4.263 It was believed that this approach would ensure that the TNUoS charging arrangements remained consistent with the NETS SQSS if wind generation were to drive transmission investment at peak in the future.
- 4.264 The mechanism by which this linking could be achieved would be to add a plant type (PT) multiplier to the Peak Security element of the TNUoS tariff. The Workgroup considered that this multiplier would be set to 1 for conventional plant and 0 for intermittent plant in the Original proposal.

**Q3: On the subject of whether intermittent generation should be exposed to a Peak Security element of the tariff, do you have any views in addition to those discussed by the Workgroup?**

**Potential Alternatives**

**(i) Sharing potential alternative 1 – Sharing applies to local**

- 4.265 The Original proposal would apply the concept of sharing to the entire wider transmission network (i.e. it would reflect the differential impact on incremental network costs of generation plant with differing technology characteristics). However, when planning local transmission circuits for generation, the Original proposal recognises that this is normally done on the basis of generation plant capacity (MW) and the various other characteristics of plant therefore do not tend to lead to a different impact on the need for transmission capacity.
- 4.266 A number of Workgroup members challenged this assumption, arguing that there is some sharing on local transmission networks and that there is likely to be more in the future. There was general agreement in the Workgroup that transmission network sharing should be signalled to generators where it occurs, but there was debate over the timing of the charge, the evidence required and how exactly this should be translated into TNUoS tariffs.
- 4.267 The Workgroup discussed how local transmission circuits would be planned and also requested a clarification of the distinction between network capacity treatment in the transmission TNUoS charging calculation and transmission network planning. These are covered in turn below.
- 4.268 The discussion of the Workgroup in this area related to the diversity issue outlined above in that it considers the concept of sharing on local transmission circuits where it is actually deemed to exist (or could potentially exist in future). The group considered that this was similar to the diversity it sought to apply the concept of the differential impact on incremental constraint costs of different generation plant types with a greater granularity than the Original proposal. Both were considered to be

seeking to adjust the transmission boundary where sharing is accounted for.

### Planning of 'Local' Circuits

- 4.269 Network investment decisions are made by Transmission Owners in accordance with their Transmission Licences. These stipulate that the network should be planned to the NETS Security and Quality of Supply Standards (NETS SQSS). Within the NETS SQSS, the nearest concept to 'local' (in the TNUoS sense) is that of a ***Generation Circuit***, which is defined as, "The sole electrical connection between one or more onshore generating units and the Main Interconnected Transmission System i.e. a radial circuit which if removed would disconnect the onshore generating units."
- 4.270 For generation TNUoS tariffs, the locational element is comprised of both a 'local' and 'wider' component. The boundary between the 'local' and 'wider' transmission network, for charging purposes, is defined on a nodal basis. From the generator's perspective the wider transmission network begins at the first Main Interconnected Transmission System (MITS) node. MITS nodes are defined, in the CUSC, as:
- Grid Supply Point connections with 2 or more transmission circuits connecting at the site; or
  - Connections with more than 4 transmission circuits connecting at the site.
- 4.271 Therefore, any transmission circuit between a generator and the first MITS node is considered a ***Local Circuit***.
- 4.272 Whilst there is significant overlap between the definition of a *Generation Circuit* and a *Local Circuit*, the two are not synonymous. Nevertheless it is likely that, in most instances, a *Generation Circuit* would be a subset of the *Local Circuit* (i.e. the *Local Circuit* would be expected to extend deeper into the transmission network).
- 4.273 *Generation Circuits*, as defined in the NETS SQSS and set out above, are designed to background conditions that set the active power (MW) output of the power station equal to its *registered capacity*. Registered Capacity is defined as the maximum amount of active power (MW) deliverable or normal full load capacity (in the case of a CCGT or power park module) as declared by the generator at the Grid Entry Point.
- 4.274 This is equivalent to a generator's Connection Entry Capacity (CEC) as defined in the CUSC, which a generator declares within the Standard Planning Data submissions forming part of their application for connection to the transmission system.
- 4.275 Consistent with the above, the NETS SQSS states that the minimum capacity of a *Generation Circuit* is normally planned to 100% of CEC. This is currently under review in GSR-010,<sup>2</sup> which proposes to formalise existing practice in some geographic areas within GB where the characteristics of the generation connected can be taken into account when planning *Generation Circuits*. Under these GSR-010 proposals the deterministic minimum criteria would be amended to reflect the differing size (capacity, MW) and intermittency (load factor, %) of new generation technology, effectively reducing the level of redundancy provided for small and intermittent generation. The Workgroup noted that GSR-010 was not

---

<sup>2</sup> <http://www.nationalgrid.com/NR/rdonlyres/0B7065FD-CA38-44A3-9162-8E2CBEB66A6E/54246/EntryWGReportFinalJune2012.pdf>

proposing to alter the capacity, only the number, of transmission circuits for a given connection.

- 4.276 Regardless of the minimum capacity requirements dictated in the NETS SQSS it is generally not possible for the Transmission Owner to match generation capacity requirements exactly in an economic manner (due to the finite amount of varying sizes of transmission equipment available). As such, the actual transmission network capacity put in place is often greater than the minimum required by generation.
- 4.277 Beyond *Generation Circuits*, but within the definition of a *Local Circuit*, it is also possible that the TO will be aware of a number of generators wishing to connect, but will not have financial commitment from all of them. In this case, where it is not possible to economically build incremental transmission capacity for each project (such as is the case with island connections), the TO would need to take a view as to how much generation may come along in future. In these instances it is also likely that transmission circuits could be oversized to accommodate future generation development in the most economic manner.
- 4.278 The Workgroup noted that, whilst the NETS SQSS sets out minimum transmission capacity requirements, the nature of available transmission assets and the timelines of multiple generation projects wishing to connect will often lead to the most economic investment on *Local Circuits* being one where the physical transmission capacity being put in place (by the TO) is greater than 100% of that required by the minimum deterministic standard.
- 4.279 There was further debate in the Workgroup as to whether, GSR-010 aside, the NETS SQSS minimum standards would necessarily apply in the case of a connection for an intermittent generator. Once beyond the definition of a *Generation Circuit*, but possibly still within the definition of a *Local Circuit*, the NETS SQSS allows the TOs to make judgement as to the likely output of a generator over the course of a year of operation when setting out minimum transmission capacity requirements.
- 4.280 Particularly for intermittent generators connected via relatively expensive transmission technology there is precedent for reduced minimum transmission network capacity requirements as a result of making an economic trade off between the value of lost energy versus the cost of additional transmission capacity (i.e. cost benefit analysis - CBA). This precedent is codified for offshore transmission connections. Proposed generation connections to the islands share some of the defining characteristics of offshore transmission for the purposes of planning transmission network capacity. Some members of the Workgroup noted that there were also many differences between island connections and offshore.
- 4.281 In these cases the Workgroup noted that the economic capacity of a *Local Circuit* connection would therefore be dependent on the outcome of the aforementioned cost benefit analysis, coupled with the specificity of capacity with which the relevant transmission assets are available (as set out in paragraph 4.275) and taking account of any uncertainty in the generation background.
- 4.282 Whilst the exact level of transmission capacity that may be built on a local circuit is somewhat uncertain, the Workgroup discussed the fact that there is not an exact link between transmission planning (NETS SQSS) and transmission charging (TNUoS) due to planning necessarily occurring on the basis of all background conditions and the TNUoS charging calculation being undertaken on the basis of the incremental impact on transmission investment costs (i.e. the charging calculation, both under the existing



methodology and the Original proposal, does not explicitly take account of the physical transmission network capacity available on the network).

- 4.283 Some Workgroup members were not comfortable with this concept and further discussion ensued on the difference between transmission network planning (NETS SQSS) and transmission network charging (TNUoS).

#### Planning versus Charging of 'Local' Circuits

- 4.284 The Workgroup sought to gain insight into, and examples of, the main differences between the planning of transmission network capacity on radial circuits connecting both generation and demand and the TNUoS charging calculation associated with these transmission circuits.
- 4.285 The Workgroup noted that the planning of transmission network capacity is a relatively complicated process that must take a large number of factors into account, some of which are set out above. However, the intention was not an attempt to explain all the intricacies of transmission network planning, but rather to seek to highlight the main distinction between planning and charging for transmission.

#### Network Planning

- 4.286 When assessing the impact of additional generation connecting at a point on the transmission network the transmission network planner will model the anticipated generation capacity (MW) and its output (MWh) over time and investigate the transmission network power flows across the system that result from the disposition of all the generation relative to the location of demand.
- 4.287 Where issues arise, both the transmission network reinforcement options and any system operational solutions available are considered to solve them in the most economic fashion. The Workgroup noted that the key characteristics of this process, relevant to the comparison, are, that transmission planning:
- 1) is done against forecasts of the total additional generation capacity that may connect or disconnect in a particular part of the transmission network which, due to limited User commitment (i.e. financial commitment) and a general inability to predict the future, also includes a level of uncertainty; and
  - 2) must work within the limitations of the finite number of transmission network reinforcement solution options, each available in only a limited number of standard sizes (i.e. where transmission reinforcement occurs it is generally 'lumpy' in nature, such that capacity will seldom match requirements MW for MW).
- 4.288 This concept of capacity in the context of transmission network planning is illustrated in Figure 32, below, showing that actual investment in transmission capacity is put in place to accommodate generation capacity, but rarely matches requirements on a 1:1 basis due to a number of factors.

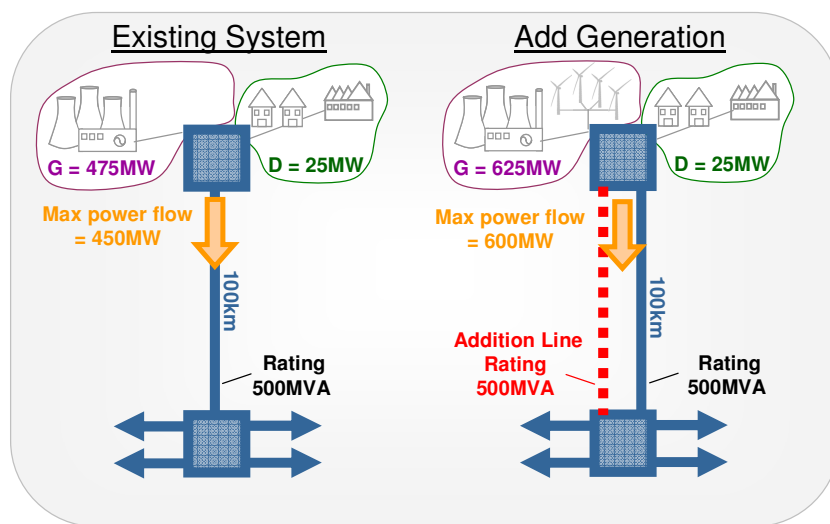


Figure 32 – Capacity in a transmission network investment context

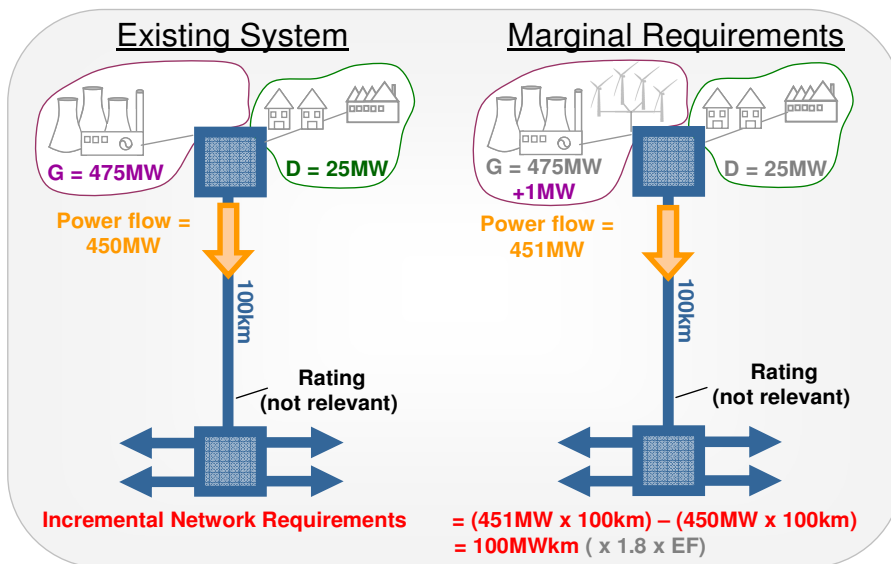
### Network Charging

4.289 TNUoS charges are based on the principle of Investment Cost Related Pricing (ICRP), which calculate the incremental cost of transmission investment. The Transport model, used to calculate the locational signal calculates the incremental costs of investment in the transmission system which would be required as a consequence of an increase in generation (or demand) at each connection point on the transmission network.

4.290 One measure of transmission investment costs is in terms of MWkm (i.e. unit capacity over a distance). Hence, marginal transmission network costs are estimated initially in terms of increases or decreases in units of kilometres (km) for a 1 MW injection on to the transmission system. The Workgroup noted that the key characteristics of this process, relevant to this comparison, are that the TNUoS charging calculation:

- 1) Uses the impact of the incremental 1 MW injection in conjunction with the cost and length of existing transmission routes to calculate the incremental cost. In doing so it assumes that the cost of future additional transmission network capacity will be the same as that currently on the transmission network; and
- 2) Assumes that additional transmission network capacity (MW) requirements for a generator of a given size can be added to exactly the capacity (MW) size required for that generator.

4.291 This concept of capacity in the context of TNUoS charging is illustrated in Figure 33, below, showing that charging for transmission network capacity assumes that the transmission network can be sized exactly to meet the requirements of generation. The incremental cost signal is based on the costs and lengths of existing transmission routes and technologies.



**Figure 33 – Capacity in a TNUoS ICRP context**

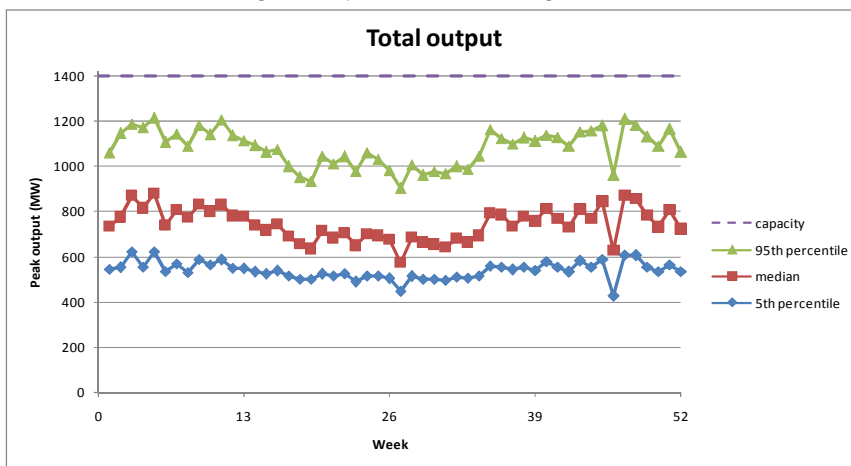
- 4.292 From the above, the Workgroup appreciated that the incremental nature of the TNUoS charging calculation meant that it does not explicitly take account of the physical transmission network capacity available on the network.
- 4.293 The Workgroup agreed that the incremental impact on transmission network investment costs from generators with different characteristics would not vary for local transmission circuits planned in accordance the deterministic criteria. (i.e. the relevant characteristic in this case would solely be the capacity of the generator in question).
- 4.294 However, there was a view from some Workgroup members that for connections of intermittent generation with relatively expensive transmission technology, as seen with offshore connections and described briefly above, the transmission planner may undertake a cost benefit analysis (CBA). In many cases this CBA could underpin transmission funding requests to Ofgem.
- 4.295 The Workgroup surmised that as part of this CBA, Transmission Licensees may need to develop annual generation profiles for different generation technology types. In this instance some Workgroup members believed that any counter-correlation between generators using the same local transmission circuits could support the economic case for sharing of that transmission capacity. Others in the Workgroup believed that, for local circuits planned on the basis of capacity, this economic case would not be apparent.
- 4.296 An introduction to research commissioned by some Workgroup members, undertaken by Heriot-Watt University, was presented to the Workgroup in a meeting during November 2012. The analysis behind the summary provided to the Workgroup looked at individual and combined generation profiles in relation to power exports from the islands relative to varying amounts of transmission network capacity. The analysis was centred on the Orkney Islands which, at least initially, will be connected to the mainland via a local transmission circuit.
- 4.297 Orkney Islands wind, wave and tidal data was used together with response characteristics of typical generation plant. The method used statistical analysis to isolate and represent non-random and random variations in output over the year and build up probabilistic half hourly generation profiles for each generation technology type. This dataset then underpinned a number of generation scenarios which give a picture of how

generation technology type combinations might collectively export power from the islands using the island transmission connection.

4.298 During the Workgroup meeting in November, where this analysis was presented, an example of 300MW wind generation, 600MW wave generation and 500MW tidal generation (i.e. a total installed generation capacity of 1,400MW) was used, which was called “Orkney Gone Green 2022”.

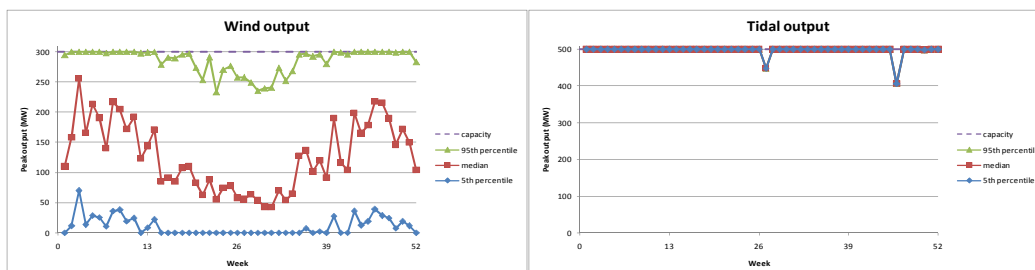
4.299 The Workgroup was informed that one thousand simulations were run of each half hour comprising a year of operation (i.e. 1,000 x 17,520) on the Orkney Gone Green 2022 background. Whilst the group did not have sufficient time to fully understand the modelling methodology utilised in this research, it was agreed that, provided the modelling methodology was sound, the number of simulations undertaken was sufficiently statistically robust to cover the vast majority of potential outcomes.

4.300 The Workgroup was shown a plot of peak weekly outputs (i.e. 52 data points, each representing the peak output of generation in the 1,000 simulations undertaken on the 336 half hours making up one week). The plot for the combined background of all generation (in the Orkney Gone Green 2022 background) is shown in Figure 34, below.



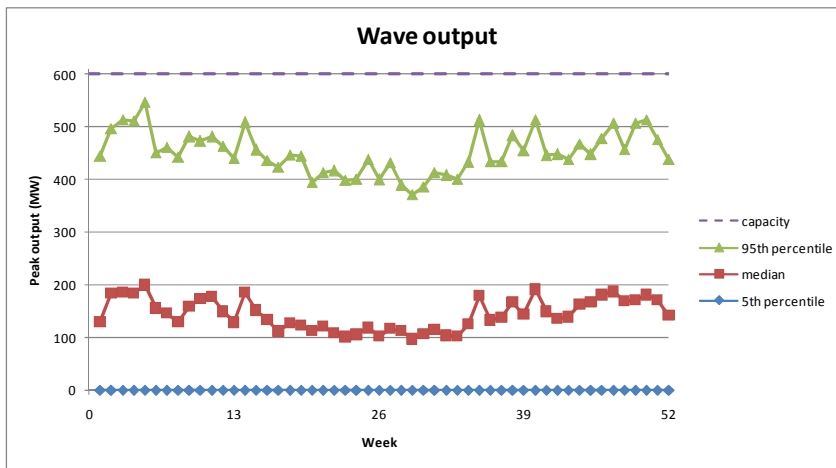
**Figure 34 – Weekly peak output for all 1,400MW of generation capacity**

4.301 The Workgroup spent some time debating and attempting to understand what the plot was actually demonstrating. More of the same plots were also shown for each generation technology type in isolation, which showed that for the wind and tidal technologies modelled on Orkney, peak weekly output would reach installed capacity in a high number of weeks within the 95<sup>th</sup> percentile of simulations. These are illustrated in Figure 35, below.



**Figure 35 – Weekly peak output for wind and tidal in isolation**

4.302 On the other hand, wave generation was shown to exhibit the lowest number of weekly peak outputs at installed capacity within the 95<sup>th</sup> percentile as shown in Figure 36, below.

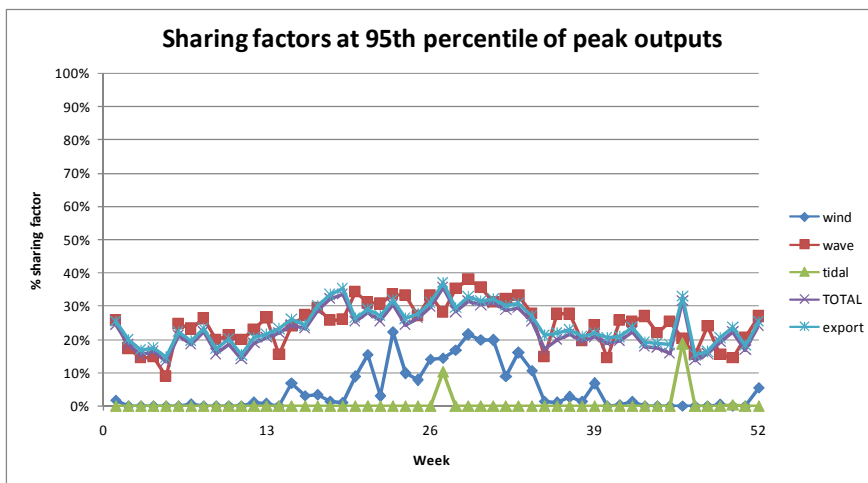


**Figure 36 – Weekly peak output of wave generation in isolation**

- 4.303 Some Workgroup members believed that, providing the modelling methodology was sound, the data showed that when wind, wave and tidal generation combined in the aforementioned proportions were situated on Orkney that the chance of the power exported, via the local transmission circuit, from the islands being equal to the installed capacity of all the generation was minimal (i.e. it appeared that a maximum output of 1,200MW occurred within the 95<sup>th</sup> percentile of the 1000 x 17520 simulations).
- 4.304 Others in the Workgroup were concerned that, whilst this may be the case for the 95<sup>th</sup> percentile, that there may yet be other simulations outside this range where weekly peak combined generation output did reach installed generation capacity and that the cost of these periods could be high given the subsidies in place for these generation technology types. Yet others in the group were of the view that if the transmission network was planned on the basis of installed generation capacity, then the TNUoS charging arrangements should reflect this.
- 4.305 The Workgroup was also introduced to a concept set out in the model as the “sharing factor” expressed as:

$$\text{SharingFactor (\%)} = 100 \times \left( 1 - \frac{\sum_{\text{devices}} \text{outputs}}{\sum_{\text{devices}} \text{rated capacity}} \right)$$

- 4.306 This “sharing factor”, expressed as a percentage, was meant to show the percentage of spare transmission network capacity at any one time, if the network was sized to rated generation capacity. The Workgroup was shown a plot of this “sharing factor” similar to those above across 52 weeks, which is replicated in Figure 37, below. Some Workgroup members believed that this plot demonstrated that “sharing” by generation of between 10% and 40% of transmission capacity occurred across a year.



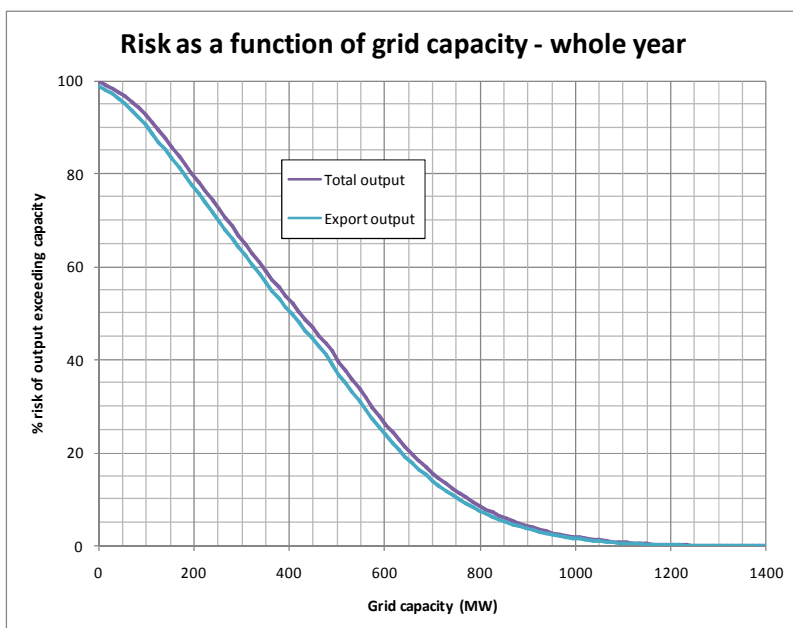
**Figure 37 – Deemed "Sharing" factors of peak outputs**

4.307 Subsequently the Workgroup was introduced to a "risk factor" expressed as:

$$\text{Risk(\%)} = 100 \times \frac{\text{Count of simulations where } \sum_{\text{devices}} \text{output} > \text{Grid capacity}}{\text{Count of all simulations}}$$

4.308 This "risk factor" quantified the percentage of the total number of simulations (i.e. 1,000 x 17,520) that the combined output of each of the generation technology types would exceed the transmission network (i.e. "Grid") capacity if that capacity were sized to match the total capacity of generation.

4.309 Figure 38, below, shows this "risk" factor plotted against transmission network capacity (if transmission network capacity = installed generation capacity). The Workgroup noted that, for example, the combined output of the generation only exceeded 850MW for 5% of the total number of simulations run.



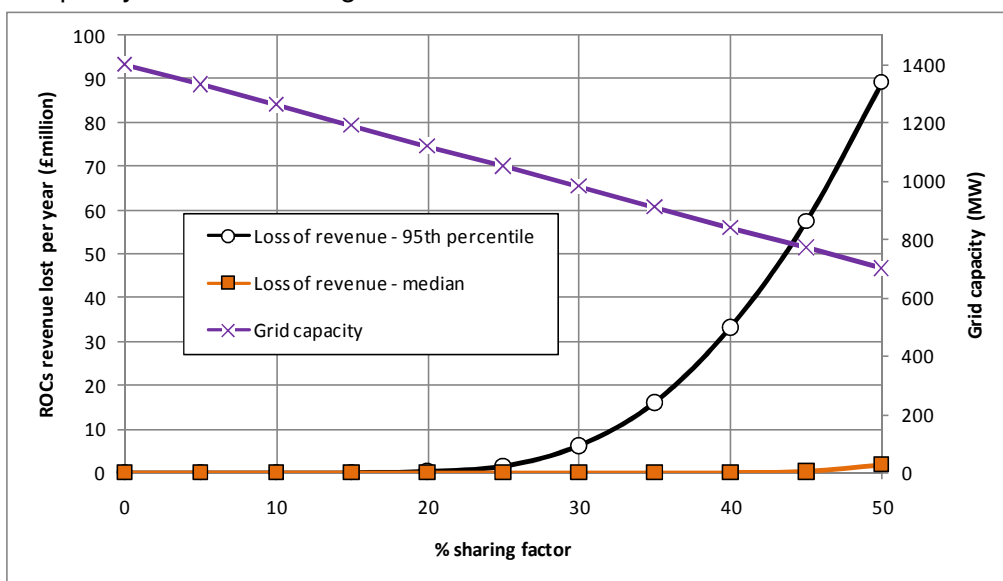
**Figure 38 – "Risk" against transmission network capacity**

4.310 Some Workgroup members believed that the above plot showed that generators could simply book a Transmission Entry Capacity (TEC) that was lower than the generation capacity, such that the Transmission Licensee could build less transmission network capacity and that this

would be reflected in the TNUoS tariff they were charged. Others were of the view that, as individual generation projects did not have the sight of other generation projects, this approach of booking less TEC for a single generation project was not viable. These members also believed that taking this view (about TEC) precludes reflecting any benefits of counter-correlation of output between different generation technologies; such as wind, wave and tidal in the Orkney Gone Green 2022 scenario.

4.311 It was also pointed out that for onshore and island transmission connections, the relevant TO will often be planning the transmission network for a combination of demand and multiple generation Users and would usually be the party making the economic investment case.

4.312 Finally, against the Orkney Gone Green 2022 scenario, the Workgroup was also shown a graph showing the potential loss of Renewable Obligation Certificate (ROC) revenue against transmission network ("Grid") capacity and the "sharing factor".



**Figure 39 – Loss of ROC revenue vs. transmission network capacity and "sharing factor"**

4.313 The plot in Figure 39, above, shows that for a transmission network capacity of approximately 1,150MW, the loss of ROC revenue would be negligible for both the median and 95<sup>th</sup> percentile of the simulations undertaken. It also shows that the loss of ROC revenue increases rapidly for lower network capacity in the 95<sup>th</sup> percentile, but only a very small amount in the median. The Workgroup noted that the analysis estimated that a transmission network capacity of half the installed generation capacity would lead to £90m per annum in lost ROC revenue in the 95<sup>th</sup> percentile.

4.314 Some Workgroup members believed that the analysis demonstrated that:

- There is likely to be an economic case for building local transmission circuits that are sized under the combined rated capacity of the various generator technology types using (or expected to use) the circuits; and
- That this case holds for intermittent, renewable generators sharing access to a local transmission circuit;
- That there may be a case for different generation technology types sharing between low carbon, intermittent, generation anywhere on the network.

4.315 The Workgroup noted that any potential local sharing alternative would need to apply to all local transmission circuits, not only those connecting Scottish islands.

4.316 There was general agreement that where the local transmission network is planned on the basis of there being network sharing by generators, that this should be reflected in TNUoS tariffs. There was a range of views within the group over whether local transmission circuits that were planned in accordance with the deterministic standard to the full capacity of the generation (or their TEC) should have a sharing element in the TNUoS tariff.

4.317 The possible methodology for incorporating this sharing due to explicit counter-correlation was discussed by the Workgroup. With reference back to the issues of diversity, set out above, it was clear to some Workgroup members that this may require a slightly different approach to that taken on the wider transmission network where counter-correlation may not be the main driver behind the differential impact on incremental costs by generators of different plant types. Some in the Workgroup considered that it would be possible to incorporate the results of the analysis presented for Orkney to the diversity options and alternatives set out above.

4.318 The Workgroup debated a number of potential alternatives for reflecting generation sharing on local transmission circuits, where it was demonstrated that sharing would occur due to explicit counter correlation of the generators in question. Four possible options were identified for reflecting sharing into the local circuit TNUoS tariff:

- i) Add a sharing component to the local circuit TNUoS charge by applying the ALF to any calculated tariff;
- ii) Add a sharing component to the local circuit TNUoS tariff that is calculated on a specific amount of calculated sharing;
- iii) Establish a new designation of “shared local” and apply a sharing factor to the local circuit TNUoS tariff; and
- iv) Establish a new designation of “island local” and apply a sharing factor to the local circuit TNUoS tariff.

i) Add a sharing component to the local TNUoS charge by applying the ALF to any calculated tariff

4.319 This approach would use the five year average based ALF, as set out in the Original proposal, as the sharing factor for all local transmission circuits. The benefit of this option is that it is simple in application due to being the same as the wider TNUoS tariff sharing factor. However, the Workgroup felt that it would not be cost reflective as in many cases there is no sharing of local transmission circuits. On that basis the majority of the Workgroup felt it tipped the balance between simplicity and cost reflectivity, and was not supported.

ii) Add a sharing component that is calculated on a specific amount of calculated sharing

4.320 The Workgroup believed that this would allow for a sharing element to be factored into the local TNUoS tariff on a more specific basis. The difficulty with this potential alternative would be in deciding what proportion of sharing was present. Two sub-options were developed, both of which were considered as potential alternatives.

*a) Sharing factors derived from the assumptions made by the TOs when planning the transmission network*

4.321 This potential alternative would draw on the cost benefit analysis undertaken by Transmission Licensees and would require communication between the Transmission Owners (TOs) and System Operator (SO) on



the sharing factors used. The Workgroup agreed that there should be some oversight to check economic efficiency of the assumptions, although most thought this implicit in the transmission network planning process which requires Ofgem approval. Another route by which this could be achieved is through checks and balances of the SO through the STC.

- 4.322 Linking any local transmission circuit sharing factors to TOs planning assumptions would provide stability – once agreed and approved – and could be considered consistent with the evidence base used for the Original. It may also be considered consistent with the concept of implicit sharing of the Original, as opposed to explicit sharing and a reliance on third parties to set TNUoS tariffs.
- 4.323 Some in the Workgroup thought that the signalling of local circuit sharing could unlock some areas transmission network development projects currently stalled by the need, for economic efficiency, to corral many dispersed and diverse generators, but with generators unwilling to be the first (high-risk) mover.
- 4.324 Before the factors are agreed by the TO / SO / the Authority they might be difficult for Users to predict unless there was some published guidance on their use in cost benefit. The Workgroup felt in any event that there would need to be transparency in the setting and agreeing of the factors.

*b) Sharing factors derived from the actual mix of generation connected via a local transmission circuit; updated annually*

- 4.325 This approach would update the local transmission circuit sharing factors using specific data on generators joining each specific local transmission network. Suggestions included:
- a simple ratio of capacity (MW);
  - a simple ratio of generator annual load factors (%); and
  - modelling counter-correlation factors.
- 4.326 Some in the Workgroup believed that a simple ratio of (MW) capacity would be inaccurate where there were diverse generation technology types. These members also believed that moving down the list increases accuracy, and the majority agreed that the last is more complex than the first two. Annual updates would give only little stability as the local circuit TNUoS tariffs would be updated each year. It was noted that TNUoS is in any event annually recalculated, although some in the Workgroup were concerned that tariff swings due to sharing may be quite pronounced. Other Workgroup members were of the view that the analysis on volatility, in Annex 11 – Comparison of Tariff Volat, seemed to indicate that volatility could be reduced in terms of the Original proposal.
- 4.327 The Workgroup debated whether a simple ratio of capacity provided equivalence with the existing offshore TNUoS charging methodology where generator capacity exceeds the offshore transmission network export capacity. Some believed that this could be achieved by allocating annual revenue recovery across total generator MWs rather than circuit capacity MWs (or a simple ratio of load factors). This may be appropriate when using specific costs to derive an expansion factor. Other Workgroup members believed that the use of revenue to calculate a TNUoS tariff for a transmission circuit owned by an incumbent onshore Transmission Owner may not be possible, or could be inconsistent with the rest of the charging methodology for non-OFTO assets.

iii) Establish a new designation of “shared local” and apply sharing to the calculated TNUoS tariff

4.328 This method would introduce some kind of designation of certain local transmission circuits in order that they can be charged, for the purposes of TNUoS, as shared. This might be on the basis of a certain level of diversity using the transmission circuit(s) or some other defining feature. The Workgroup could not define what this might be, so this option was not developed further.

iv) Establish a new designation of “island local” and apply sharing to the calculated TNUoS tariff

4.329 This potential alternative would allow certain island transmission circuits to be designated as “island local” and then apply a sharing factor (ALF or something else as agreed) to any calculated TNUoS tariff. However, there would need to be a demonstration that local transmission networks on an island were being shared by generators, and a CUSC definition of “islands” would be needed which set this out clearly and takes account not just of the Scottish islands (generally the main focus of the debate around island TNUoS charges to date) but all islands in GB (to avoid any unintended consequences) in a non-discriminatory manner.

4.330 The Workgroup felt that this was essentially the same as potential alternative (iii), above, but with islands as the designated feature. There was majority agreement in the Workgroup that islands per se could not be used as a defining feature unless there was something unique about island transmission circuits.

Sharing with Demand

4.331 All of the debate described above under local sharing, above is concerned with generation sharing transmission network capacity with other generators. Some members of the Workgroup believed that demand also ‘shares’ local transmission capacity in so far as its presence can reduce the need for export capacity. There was some in-depth discussion within the Workgroup around whether this is, or is not, already accounted for in the TNUoS charging methodology.

4.332 Others Some in the Workgroup noted that, as the TNUoS charging signal is calculated in an equal and opposite manner between generation and demand, the netting effect of demand on transmission network power flows (and hence the need for export capacity) is already taken into account. These members believed that the comparison of transmission network capacity in a planning context (Figure 32, above) and transmission network capacity in a TNUoS ICRP context (Figure 33) made it absolutely clear that generation did not share transmission network capacity with demand.

4.333 Generation TNUoS is an incremental signal which does not see spare or under-capacity, so is neutral to under- or over-sizing of, cable transmission capacity against booked generation capacity (as set out above).

4.334 Nevertheless some Workgroup members noted that Demand TNUoS in its raw form is equal and opposite to the generation signal at a node. However, a proportion of Demand TNUoS is charged against usage rather than booked demand capacity and embedded generators are credited with some of the import avoided by their presence. There was concern in the group that this should not be double-signalled through Generation TNUoS

4.335 The Workgroup debated further the nature of the equal and opposite nodal TNUoS tariffs for demand and generation, and whether these gave

comparable locational signals. In the context of the islands, generation TNUoS has a highly specific nodal local charge, whereas nodal demand TNUoS calculated in the TNUoS model is averaged across the whole of the north of Scotland demand TNUoS charging zone, including the islands (as it is in all 14 GB demand TNUoS charging zones). So whilst some believed that the generation TNUoS is an extremely sharp signal on the islands, they also believed that demand TNUoS is very diluted; although it was noted that this effect was replicated (to a lesser extent) across GB, where the generation and demand TNUoS charging zones are different.

- 4.336 Disaggregating Demand TNUoS has been suggested in the past, which should benefit island-based consumers. One member pointed out that the Common Tariff Obligation (CTO) prohibits suppliers giving consumers in the north of Scotland different terms on the basis of location. This is designed to protect them from high distribution costs in the Highlands and islands of northern Scotland. SHEPD's distribution business is also subsidised by around £53m a year, through TNUoS charges on suppliers, to keep average costs down.
- 4.337 Nevertheless, some in the Workgroup believed that disaggregating demand TNUoS could be possible.
- 4.338 However, the Workgroup noted a number of issues associated with this possible approach set out below.
- 4.339 Firstly, the removal of the CTO could only be undertaken by the UK Government, rather than via a CUSC Modification.
- 4.340 Secondly, if it were removed it would expose those parts of the Highlands and islands in the north of Scotland which did not have generation in their locality to higher transmission and distribution charges.
- 4.341 Thirdly, it was noted by some that CMP213 only relates to transmission charges which, according to the Authority<sup>3</sup>, account for 5% of a typical household bill whilst distribution charges account for 18%. Thus even for those islands which did have generation in their locality, if the transmission element of the island consumer use of system (T & D) charges (23% of the total bill) were to be negative it was unlikely to counteract the much higher distribution charge that would arise if the CTO were to end (and consumer on that island were then exposed to the actual use of system (T & D) charges for the network associated with the island).
- 4.342 Fourthly, in the future, it would expose those parts of the Highlands and islands in the north of Scotland which did have generation in their locality to higher transmission and distribution charges if (when?) that generation left the system.
- 4.343 Fifthly, much of the generation on the islands is renewable and there is already a well established mechanism for local communities to share the benefits of having that generation in their locality via the 'Community Benefit' arrangements. Some Workgroup members wondered if Demand Disaggregation were to be implemented would this result in any net benefit to local communities if it resulted in a corresponding reduction in 'Community Benefit'.
- 4.344 Sixthly, any benefits that accrue from the sharing of the local transmission assets would, currently, be shared (via the CTO obligations) with all demand consumers in the north of Scotland (including those on the islands) who have, since privatisation, been paying a higher use of system charge to help pay for the higher costs of operating and maintaining the

---

<sup>3</sup><http://www.ofgem.gov.uk/Media/FactSheets/Documents1/household-bills.pdf>

transmission and distribution networks in the north of Scotland. This, in the view of some Workgroup members, was equitable as it would mean that any benefits for demand of local sharing would be shared with all those consumers (in the north of Scotland demand TNUoS zone) who had paid the higher charge in the past. Otherwise there was a danger that where transmission network costs (to certain localities) are high (or a 'dis-benefit') they are 'socialised' but where there are 'benefits' (in terms of low, or negative, transmission network costs) these are 'localised'.

4.345 As a result of the above, the Workgroup did not develop any potential alternatives for sharing with demand.

**(ii) Sharing potential alternative 2 – Alternative Allocation of MWkm**

4.346 In the Original proposal circuit flows in the Transport model are compared between the two background load flows, and the background settings causing the higher transmission circuit flow is considered as the triggering criterion. The logic behind this approach is that, where transmission investment is made against these deterministic criteria, it would be done to facilitate the most onerous condition. This is considered to remain robust when considering the impact of an incremental 1 MW on the transmission network, which assumes that the network can be optimally sized (i.e. it does not take into account the capacity of the transmission network).

4.347 The Workgroup considered a potential alternative approach where two separate DC load flow backgrounds are set as per the Original proposal, using background scaling factors consistent with the NETS SQSS.

4.348 In the potential alternative approach, transmission circuit flows are still compared between the same two load flows, but rather than defining an entire transmission circuit as either Peak Security or Year Round, the relative proportions of flows on that circuit are compared and apportioned between the two criteria. The reasoning behind this approach sets aside the notion of a 'triggering criterion' and considers that investments in transmission network capacity would be utilised under both the Peak Security and Year Round conditions and, as such, should be considered under both criteria.

4.349 The process is best illustrated through use of an example. Consider the circuit shown in **Error! Reference source not found.**, below.

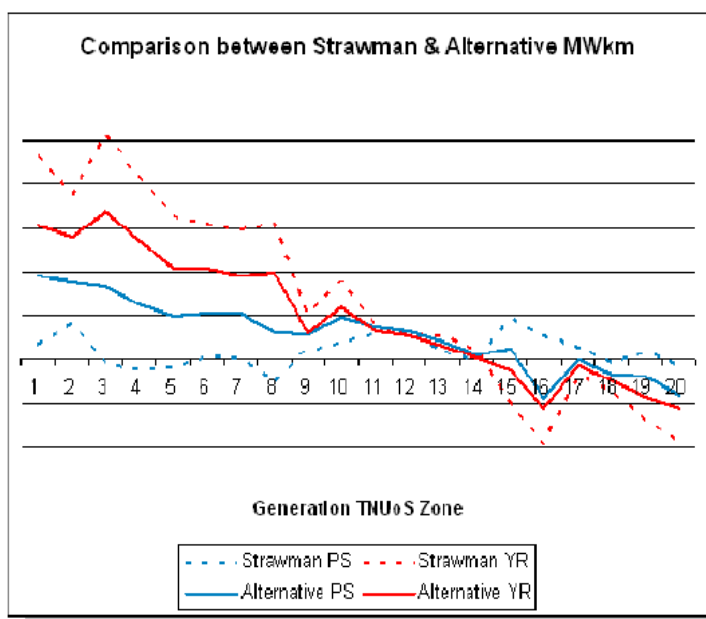


**Figure 40 – Ratio of power flows for PS and YR**

4.350 In this example, a load flow using the Transport model has resulted in a Peak Security flow of 600MW on transmission circuit A-B and a Year Round flow of 400MW. Under this potential alternative approach, 60% of the MWkm 'cost' of transmission circuit A-B would be attributed to the Peak Security criterion, whilst 40% of the MWkm 'cost' of transmission circuit A-B would be attributed to the Year Round criterion. The Original proposal, as it currently stands, would apportion 100% of the MWkm 'cost' to the Peak Security background (and 0% to Year Round). This potential alternative approach would not alter the incremental MW assessment.

4.351 The impact of this potential alternative approach to apportioning MWkm has been assessed using the 2011/12 Transport model. Figure 41, below, shows the unadjusted zonal MWkm for both the Original proposal ("Strawman") and this potential alternative ("Alternative") approach for both backgrounds. It can be seen that this potential alternative approach would reduce the zonal MWkm attributed to the Year Round element and

increase the Peak Security MWkm relative to the Original Proposal. The overall zonal MWkm would not alter significantly.



**Figure 41 – Comparison of relative MWkm for Original ("Strawman") and potential alternative ("Alternative")**

4.352 Whilst there was no clear consensus amongst the Workgroup members as to which approach was best from a theoretical perspective, there were no strong views that the approach set out in the Original proposal should not remain. Therefore no changes were being considered in this area.

**(iii) Sharing potential alternative 3 – Single background – Year Round only**

4.353 The Original proposal seeks to replace the existing peak background in the Transport model with two separate background conditions, representing Peak Security and Year Round conditions respectively. Whilst the existing loadflow in the Transport model sets up the peak demand background by scaling down the contracted (MW) TEC of all generators in GB equally to meet total GB demand, the Original proposal would setup two peak demand conditions and scale generation differently under each to reflect the values used in the NETS SQSS. Some of these values would be fixed (charging) year on (charging) year and some would vary depending on the demand level in the charging year under consideration.

4.354 Some members of the Workgroup raised the possibility of not utilising a dual (Peak Security and Year Round) background approach and, instead, calculating TNUoS tariffs on the Year Round background only, thus leading to only a single element of the wider locational TNUoS tariff on this basis that this would be less complex and, in their view, potentially more robust.

4.355 It was noted that this approach would be inconsistent with the approach taken to planning transmission network capacity in the NETS SQSS and also inconsistent with the terms of the SCR Direction which set out that the CMP213 modification proposal should set (TNUoS) tariffs using a dual background approach:.

4.356 Nevertheless, the Workgroup believed that the use of the Year Round background only could form part of a potential alternative to address the issues of generation plant diversity (i.e. Method 3), highlighted above. Therefore discussion on this potential alternative was taken forward in that area.

#### **(iv) Sharing potential alternative 4 – Full market model**

- 4.357 The Original proposal seeks to make incremental improvements to the existing Investment Cost Related Pricing (ICRP) TNUoS charging methodology. As such, it proposes to use the existing Transport and Tariff model, altered to reflect the dual (Peak Security and Year Round) background approach used in transmission planning and incorporate a sharing factor to account for the differential incremental cost impact of generators with different characteristics on the transmission network.
- 4.358 As part of the detailed analysis undertaken by the Workgroup, two separate market despatch models, such as those used to undertake CBA based transmission network planning, were used to explore options for a simple proxy that could be used to reflect the numerous characteristics of a generator that can have an impact on incremental transmission network costs (e.g. the Annual Load Factor in the Original).
- 4.359 One member of the Workgroup considered that a potential alternative to this incremental approach of improving ICRP would be the use of a full market model to set TNUoS tariffs.
- 4.360 The Workgroup debated this possibility and considered that there could likely be benefits associated with enhanced cost reflectivity over and above both the Status Quo and the Original proposal.
- 4.361 However, the drawbacks of such an approach were considered to be significant and included the need to obtain all the relevant characteristics such as the fuel price, efficiency, plant availability, bid price, offer price, etc., for each generator as well as updating and running a complex model each charging year. In addition the Workgroup noted that transparency and predictability of TNUoS tariffs under such an approach would likely deteriorate appreciably.
- 4.362 On the basis of the above the Workgroup agreed not to proceed with the development of this option.

#### **(v) Sharing potential alternative 5 – Separate charging background scaling factors**

- 4.363 The Original proposal seeks to replace the existing peak background in the Transport model with two separate background conditions, representing Peak Security and Year Round conditions respectively. Whilst the existing DCLF in the Transport model sets up the peak demand background by scaling down the contracted (MW) TEC of all GB generators equally to meet total GB demand, the Original proposal would set up two peak demand conditions (Peak Security and Year Round) and scale generation differently under each to reflect the values used in the NETS SQSS. Some of these values would be fixed (charging) year on (charging) year and some would vary depending on the demand level in the charging year under consideration.
- 4.364 One member of the Workgroup raised the possibility of utilising background scaling factors in the Transport model other than those introduced into the NETS SQSS by GSR-009.
- 4.365 The Workgroup considered how such an approach might work. In doing so it became clear that an entirely new set of generation scaling factors, which were still relative to the manner in which additional capacity on the transmission network is planned, would need to be developed. The Workgroup could not think of a way of doing this so that it would not be considered arbitrary in nature and, therefore, the Workgroup considered

that it would be difficult to arrive at a robust methodology using this approach.

- 4.366 In addition it was noted that this approach would be inconsistent with the approach taken to transmission planning network capacity in the NETS SQSS and also inconsistent with the terms of the SCR Direction.
- 4.367 The Workgroup considered how best to codify the background generation scaling factors that would be used and believed there to be two options:
- i) simply refer to the way TO's plan transmission network capacity without an explicit reference to the NETS SQSS; and
  - ii) hard link the generation scaling factors used in the TNUoS charging methodology to those used in to the NETS SQSS.
- 4.368 The Workgroup preferred the second approach, but noted that it would require a future modification to the CUSC should TO's change the way in which they planned the transmission network. The fact that TO's are obliged through their Transmission Licence to plan the transmission network in accordance with the NETS SQSS was deemed sufficient in this respect.

#### **(vi) Sharing potential alternative 6 – Anticipatory application of sharing**

- 4.369 The Original proposal applies the principles of sharing set out within it to all parts of the transmission network considered to be part of the Main Interconnected Transmission System (MITS; i.e. 'wider') for TNUoS charging purposes. Implicitly this would also include any island connections that are classed as 'wider'.
- 4.370 However, the Workgroup noted that some islands may initially be classed as local under the existing definition, but subsequently become wider due to a change in configuration (such that they become part of the MITS).
- 4.371 In this context, the Workgroup investigated the concept of applying the sharing approach outlined above to local transmission circuits on an anticipatory basis, especially for situations (e.g. islands) where generators find it hard to proceed individually, but may proceed collectively.
- 4.372 Some Workgroup members believed that on the basis that TNUoS is, where possible and desirable, future-looking, it should be proposed as a potential alternative to signal, through existing TNUoS charges, the benefits of future sharing of local transmission circuit(s) in order that generators make the right locational choices.
- 4.373 Two options for this forward-signalling were debated:
- i) Charging Users on the assumption there is sharing; and
  - ii) Charging Users sharing TNUoS tariffs only if sharing materialises, but publishing forward looking sharing TNUoS tariffs on a range of realistic assumptions; e.g. sharing and non-sharing TNUoS tariffs published based on connection offers or expressions of interest from generation developers, or on TO assumptions underpinning building of transmission capacity.

#### **(i) Charging Users on the assumption there is sharing**

- 4.374 Where there is not actual sharing, this is signalling the spare transmission network capacity available to generators for sharing. The Workgroup debated the circumstances under which this might be reasonable. There was general consensus that it would be difficult and probably not appropriate to do so for speculative generation sharing, not least because

there would be little if any information on which to base the generation sharing factors.

- 4.375 Some Workgroup members believed that it might be appropriate if transmission assets had been triggered and built on the assumption of generators sharing those transmission assets. The Workgroup was not clear on whether generation sharing would be taken into account when building a local circuit part of the transmission network – some thought that the TOs would include sharing in their Cost Benefit Analysis (CBA) and proceed if it made economic sense, others thought that there would be a straight match of build to booked generator TEC or CEC as set out in paragraphs 269 – 283.
- 4.376 In any event, whilst there was general agreement in the Workgroup that sharing should be reflected when and where there is actual sharing, by generators, of transmission assets, there were differing opinions on whether existing generators should pay for anticipatory transmission investment which included sharing assumptions.
- 4.377 Some Workgroup members believed that such a potential alternative would also keep TNUoS tariffs stable over time, and remove dependency on other generation projects which are unlikely to connect to the transmission network all at the same time. However, as a sharing TNUoS tariff is likely to be beneficial (lower) than one without sharing, a number of members noted that the temptation may arise for a generator to ‘engineer’ a sharing TNUoS tariff. This might be achieved by that generator setting up a number of ‘shell projects’ with some minimal underwriting, triggering transmission investments based on sharing (of those transmission assets) and then withdrawing those ‘shell projects’ prior to completing those generation projects. The proponents of the potential alternative countered that ‘gaming’ could simply be avoided by applying risk-reducing milestones such as those applying to pre-commissioning projects under post CMP192 User Commitment as a prerequisite to generation projects considered in the sharing of the assets. In any event the likelihood of sharing any risk of generators not coming forward would need to be taken into account when transmission investments go through the regulatory approval process.
- 4.378 Others in the Workgroup thought that TNUoS charges should reflect the transmission network capacity being used and were concerned about charging prior to diversity in generation on local transmission assets actually occurring. For instance, a generator of 500MW solely using a 750MW local transmission network would be using two thirds of the local transmission capacity and should be charged accordingly. If another counter correlated 500MW generator could be subsequently accommodated on the same local transmission network (without additional transmission investment), then there may be a case to charge (via the TNUoS tariff) a lower proportion to both generators so that the 1,000MW combined generation capacity shares the cost of the 750MW of local transmission assets.
- 4.379 These Workgroup members believed that, it is only when the second generator turns up that it could be said that the transmission network is actually being shared in this manner. If the second generator failed to turn up then 500MW of transmission capacity would still be needed by the first generator and it would be wrong to charge it TNUoS on the shared basis.

(ii) Publishing tariffs on the basis of sharing and not sharing

- 4.380 If sharing was to be reflected through tariffs only as and when the generators who shared were actually connected to the transmission network, some workgroup members felt that it would be important to signal



the benefits of sharing through forecasting indicative tariffs with and without sharing.

#### **(vii) Sharing potential alternative 7 – Explicit Sharing**

- 4.381 The industry began a process of reviewing the commercial framework to reflect changes in the way the transmission network is used by generators through the Transmission Access Review (TAR) process from 2007 to 2010.
- 4.382 During this process, the possibility of explicitly recognising the differential impact on transmission network costs by generators with different characteristics in transmission charging (TNUoS) and transmission access arrangements was considered in some detail through various modification proposals and alternatives.
- 4.383 Ultimately, this process culminated in the Secretary of State rejecting this explicit recognition in favour of a form of Connect and Manage. In recognition of this the Original proposal does not seek to alter the form of transmission access rights afforded to generators (in the form of Transmission Entry Capacity - TEC) through the UK Government's decision. Rather, it seeks to improve the cost reflectivity of TNUoS tariffs for generators by implicitly recognising that this sharing, of transmission network assets, takes place and is taken into account in an equally implicit manner in the transmission network investment planning process.
- 4.384 The Workgroup briefly considered the possibility of taking account of the differential impact on incremental transmission network costs from generators with differing characteristics explicitly through a change in transmission access rights.
- 4.385 It was noted by the Workgroup that the Authority had explicitly stated in their Project TransmiT SCR Conclusions document<sup>4</sup> that, "the [Project] TransmiT SCR CUSC amendment process will not seek to change users' transmission access rights."
- 4.386 The Workgroup also noted that whilst the ability for co-located generation plant to come to a bilateral agreement in order to share the same TEC (MW) already existed within the current CUSC framework<sup>5</sup> in practical terms it was not usable in near 'real time' situations. However, the Proposer also noted that this existing TEC sharing arrangement did not address the implicit assumptions made about the incremental impact on the need for additional transmission network capacity for generators on the wider transmission network.
- 4.387 One member brought forward a potential alternative for how Users could share the capacity of the wider transmission network in excess of their individual Transmission Entry Capacity - TEC (MW) holding subject to voluntary curtailment arrangements administered by the System Operator.
- 4.388 This potential alternative would allow a User to dispatch their generation plant in excess of their contracted TEC (MW), subject to (i) there being sufficient capacity on the local transmission network; and subject to (ii) that generator being fully exposed to the risk of curtailment by the System Operator. This would be in the form of an availability restriction that seeks to prevent any incremental costs of re-dispatch that may occur as a result of accommodating the additional delivered electricity on the GB electricity transmission system.

---

<sup>4</sup> Page 24, Paragraph 3.48;

<http://www.ofgem.gov.uk/Networks/Trans/PT/Documents1/TransmiT%20SCR%20conclusion%20document.pdf>

<sup>5</sup> Known as 'Temporary TEC Exchange' see:

<http://www.nationalgrid.com/uk/Electricity/Codes/systemcode/entexchange/>

- 4.389 The member considered that the TNUoS charging arrangements for this type of transmission use would require development so that the revenue requirements of the TOs are recovered in the current ex-ante manner, but that this is expected to be overly complex.
- 4.390 Whilst the Workgroup saw merit in the development of an approach for explicit sharing of transmission access rights, it was not believed that this should be developed in the context of this CMP213 Modification Proposal.

#### **(viii) Sharing potential alternative 8 – Including Circuit loading**

- 4.391 The Original proposal seeks to make incremental improvements to the existing Investment Cost Related Pricing (ICRP) TNUoS charging methodology. As such, it proposes to use the existing Transport and Tariff model, altered to reflect the dual (Peak Security and Year Round) background approach used in planning the transmission network and incorporate a sharing factor to account for the differential incremental cost impact of generators with different characteristics on that network.
- 4.392 As set out in the 'Sharing Applies to Local' section above, the Workgroup discussed the fact that the incremental nature of the TNUoS charging calculation meant that it does not explicitly take account of the physical transmission network capacity available on the network. (see **Error! Reference source not found.**).
- 4.393 One Workgroup member suggested that a potential alternative approach could be to take into account the capacity of transmission circuits and the level of power flows through these circuits relative to that capacity in the Transport and Tariff model when setting TNUoS tariffs.
- 4.394 The Workgroup discussed how this might be accomplished and considered that this approach would be similar to the Long Run Incremental Cost (LRIC) and Forward Cost Pricing (FCP) methodologies upon which the use of system charging methodology for higher voltage network users (the EDCM) of Distribution networks is based.
- 4.395 However, the Workgroup also considered whether such an approach would address the defect highlighted by the Original proposal and there was general agreement amongst the Workgroup that it did not.
- 4.396 Given that this approach would be a significant change from the current TNUoS charging methodology used for Investment Cost Related Pricing in TNUoS, that a whole host of issues associated with the use of such a methodology for transmission network charging would need to be discussed and resolved and that such an approach does not address the CMP213 defect, the Workgroup decided not to proceed with the development of this potential alternative.

#### **(ix) Sharing potential alternative 9 – Application of Load Factor to the Residual**

- 4.397 The residual component of the TNUoS tariff aims to ensure that the System Operator is able to fully recover the total allowed revenue (set under the Transmission Price Controls) for all transmission owners (TOs).
- 4.398 As such, for the 27% of total revenue to be collected from generators, the residual is currently charged on capacity, on a £/kW basis shared equally across all generators in GB irrespective of their technology type and location.

- 4.399 The Original proposal would calculate the wider locational element of generation TNUoS tariffs in a different manner by introducing both a Peak Security and a Year Round tariff component, as well as multiplying the Year Round element by a sharing factor to take account of the differential impact on incremental transmission network costs from generators of differing characteristics. The Original proposal does not propose to alter the residual element of the generation TNUoS tariff on the basis that its sole purpose is to recover the total allowed revenue.
- 4.400 The Workgroup discussed a potential alternative method to calculate the residual by basing it on energy (MWh) generated rather than generation capacity (MW). This could be done by two methods:
- (i) Using a generator's annual load factor (ALF) as part of the residual calculation to convert a £/kW figure into a £/kWh figure; or
  - (ii) Simply using total demand (minus exports) to obtain a p/kWh figure for total energy generated (which ignores the effects of losses).
- 4.401 Option (a) would allow for the final value to simply be added to the locational element of the wider TNUoS tariff. Option (b) would result in TNUoS tariffs being charged in two parts: one in £/kW (locational) and one in p/kWh (residual).
- 4.402 The Workgroup discussed the fact that using either method will result in generators with a lower annual load factor paying a lesser share of the residual, when compared to their equivalent under Status Quo and the Original proposal, as these generators will generate less over the charging year. Conversely, a generator with a higher annual load factor will pay a greater share of the residual.
- 4.403 Some Workgroup members stated that such an approach could be argued to be more cost reflective than the Original proposal, thus better meeting the Applicable CUSC Objective on cost reflectivity. Others in the Workgroup noted that the costs recovered through the residual do not represent specific transmission assets and could therefore be argued not to reflect transmission network costs.
- 4.404 Consideration was also given to the effect that generators with 0% load factor (i.e. those not generating) in a given charging year, would have on the overall revenue recovery using this approach. The Workgroup noted that in this situation, generators with a positive load factor would see an increase in their TNUoS tariffs as the value of their residual share would increase, potentially making the overall TNUoS tariffs (charging) year on (charging) year less predictable and more volatile.
- 4.405 In order to address this situation the Workgroup considered that there may be merit in splitting the residual into two parts, with 50% being energy (MWh) related and 50% being capacity (MW) related. Some believed that this may produce a more cost reflective outcome. Those who did not believe that the residual was reflective of transmission network costs did not agree.
- 4.406 The Workgroup also discussed and noted the illustrative impact on TNUoS tariffs, calculated using 2011/12 data, for different generation types and shared with the group.
- 4.407 The Workgroup noted that there would be an impact on generators in negative TNUoS charging zones, particularly those with higher load factors, but that this did not affect the locational signal. It was observed that the generation residual value, using option (a) from the above, would see an increase of around 131% from 3.284 £/kW to 7.589 £/kW, based on the load factor assumptions utilised in the analysis. The residual value

charged on energy generated was also calculated as 0.087p/kWh (it was noted that this value was calculated including energy exported).

4.408 The Workgroup also debated the pros and cons of such an approach. This is summarised in Table 5, below.

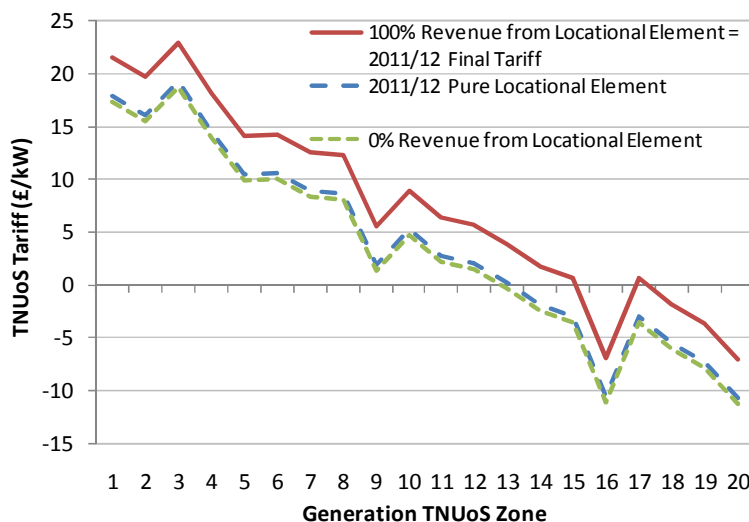
Pros	Cons
<ul style="list-style-type: none"> <li>• Investment in the transmission network is dependent on the size of connections, larger connections are provided with a greater level of transmission assets. The NETS SQSS proposal show this with multiple busbar and two or three transmission connection for the largest power stations. Smaller power stations receive a much lower standard of transmission connection. In general larger power stations can have higher annual load factors thus charging the residual on an annual load factor basis would bring an element of cost reflectivity with this aspect of transmission design.</li> <li>• Charging the residual on an energy (MWh) capacity basis will have a positive effect on market generation competition as, residual charged on a delivered energy basis would have the effect of reducing the marginal cost of power as low load factor plant will have a low marginal cost when it is running. This will bring benefits to all customers.</li> <li>• Some elements of the cost of transmission are load related based on; e.g. some maintenance cost, provision of reactive equipment etc; so charging an element of the residual on annual load factor would produce a more cost reflective outcome.</li> </ul>	<ul style="list-style-type: none"> <li>• The TNUoS charging signal is provided through the locational wider tariff component. The residual is there to recover the allowed TO revenue. Long term cost drivers on the transmission system are Users' capacity requirements. Through CMP213 adjustments are made to locational TNUoS charges to take into account sharing of transmission capacity leaving a £/kW locational charge for each TNUoS zone.</li> <li>• Economically it is important that any residual allocation does not distort the relative cost message provided by the wider TNUoS tariff. The residual is made up of transmission network costs unrelated to locational transmission costs (otherwise they should be in the locational charge).</li> <li>• Applying the residual on basis of energy (MWh), rather than capacity (MW), introduces a new cost driver and will distort the relative level of Users' TNUoS charges. This may lead to perverse and uneconomic outcomes.</li> </ul>
<ul style="list-style-type: none"> <li>• It is simple to implement and would be charged on estimated metered output with an end of charging year reconciliation in a similar way to BSUoS. Such a methodology is already in place for Demand TNUoS charges.</li> </ul>	<ul style="list-style-type: none"> <li>• It is more complex to administer (multi tariff). It may need more information; e.g. a forecast of energy will be needed to create the p/kWh charge.</li> </ul>
<ul style="list-style-type: none"> <li>• There is less risk of under/over recovery as the total delivered energy volume is more stable than the increase/reduction in TEC of power stations .</li> </ul>	<ul style="list-style-type: none"> <li>• It introduces risks of material under- or over-recovery of allowed TO revenue recovery as kWh would only ever be a forecast.</li> </ul>

**Table 5 – Pros and Cons of a volume based TNUoS residual**

- 4.409 There was no consensus within the Workgroup as to whether a change to the residual element of the TNUoS tariff was within the scope of the CMP213 Modification Proposal.
- 4.410 The Workgroup therefore decided not to develop this potential alternative any further.

**(x) Sharing potential alternative 10 - Increase locational revenue recovery**

- 4.411 The locational differences in the wider TNUoS tariff are derived from the Transport model using the unit cost of different types of transmission technologies in use on the transmission network and the incremental requirement for these different technologies based on the power flow of an incremental 1MW. The resultant nodal incremental impact is dependent on the flow of this incremental 1MW from its source (at the node in question) to the centre of the transmission network through the various circuits in proportion to their relative impedance (the value that dictates power flows through the network).
- 4.412 Rather than simply utilise the signal arising from this application of an incremental 1MW on a representation of the transmission network based on the underlying cost of the transmission assets, the Workgroup considered the possibility of collecting more revenue through the locational element of the TNUoS tariff as some believed this may increase cost reflectivity.
- 4.413 The result of collecting more revenue through the locational element of TNUoS could be to remove the need for the residual. This could be achieved by changing the centre of the transmission network, such that a different proportion of revenue is collected overall.
- 4.414 Figure 42, below, illustrates the impact of collecting both 0% of generation revenue (i.e. 0% of the 27% of total allowed revenue to be collected) and 100% of the generation revenue from the locational element of TNUoS tariffs. The TNUoS tariffs under these two scenarios are plotted against the actual locational element in 2011/12.



**Figure 42 – Moving the reference node to collect more revenue from the locational element**

- 4.415 Whilst, in practice, the model could be altered to achieve either of the above scenarios there was some debate in the Workgroup about whether (i) there would be any benefits of this approach and (ii) what it would actually be any more cost reflective than the Status Quo or the Original proposal given that the locational differentials remain unaffected.

4.416 The Workgroup also considered the possibility of collecting more revenue through the locational element of TNUoS by altering the unit cost assumptions used in the Transport model (i.e. the expansion constant and expansion factors). This began with a consideration of how transmission network costs are currently calculated and how these costs can vary for a given transmission technology.

#### Unit Cost Calculation

4.417 When calculating the generic expansion constant and expansion factors onshore, NGET accounts for the cost of the physical transmission circuit equipment (e.g. conductor, towers, and cable sealing ends) and average installation costs for each transmission circuit construction type incurred over a ten year period. No substation equipment, such as switchgear, or reactive compensation equipment is included in the calculation.

4.418 Once the typical cost for each transmission circuit construction type has been determined, the result is divided by the associated circuit rating is used to determine a £/MWkm cost for each type of transmission circuit. The weighted average cost per MWkm of installed circuit is calculated for that classification of transmission circuit (e.g. 400kV OHL, 400kV cable, etc.) based upon the total length installed. This is then annuitised, and a factor (currently 1.8%) of the pre-annuitised £/MWkm cost to cover annual transmission overheads (maintenance, rates, etc.) is added to give the final annual £/MWkm cost that forms the expansion constant or is used to determine the expansion factors.

4.419 For offshore transmission circuits, a project specific expansion factor is determined, by pro-rating the OFTO allowed revenue against each transmission asset by asset value, summing this up for circuit related items and then dividing by the larger of the circuit rating and the generator TEC (to avoid charging the generator more for an asset than the associated revenue).

4.420 In this case the OFTO allowed revenues associated with reactive compensation and harmonic filtering equipment are included within the expansion factor calculation, as onshore the equivalent equipment associated with onshore generators are owned by the generator. The cost of HVDC converter stations (that do not parallel the AC network) are also included in the circuit expansion factor calculation, as this is considered as being a cost incurred directly as a result of the chosen circuit technology.

4.421 The Workgroup considered analysis undertaken on cost data for 400kV OHL incurred over the past 10 years. It was noted that the most popular type of transmission technology used was utilised for 87% of 400kV OHL installed by NGET. Whilst there were some outliers (in comparison with the cost of this technology (-17% to +39%), these were typically short lengths in total (<3km in total for each technology installed over the 10 year period), and just under 97% of installed 400kV OHL was within +/-11% of the cost of the most utilised transmission technology.

4.422 The Workgroup noted that the largest range of transmission network costs expected would relate to 132kV overhead line, due to the difference in construction type (woodpole vs. steel tower). This can be observed by looking at the range of 132kV expansion factors used in the calculation of local transmission circuit tariffs (between 4.423 for large capacity (steel tower) double circuits, and 10 for low capacity (wood pole) single circuits). However, when looking at the wider cost, the use of an up-rating factor for the wider 132kV OHL expansion factor calculation (assuming that a higher voltage would be used for reinforcing a proportion of these circuits)

confuses the issue somewhat. Nevertheless, comparing this to offshore where the expansion factors currently range from 63 to 150, it is clear that there is a much larger cost differential.

#### Consistency with GSR-009

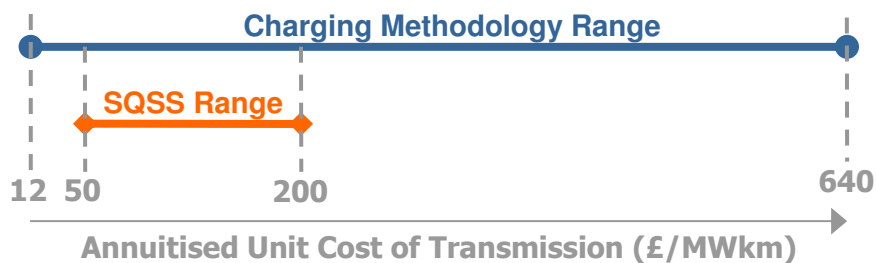
- 4.423 Whilst reviewing GSR-009, one Workgroup member noted the cost of transmission investment used within the cost benefit analysis (CBA) which developed the deterministic NETS SQSS criteria upon which the Transport model scaling factors are based within the Original proposal. This annuitised value, of £100 per MWkm p. a.<sup>6</sup>, was based on an assumption of a generic reinforcement price of £1,000 per MWkm capital over ten years. In order to test the robustness of the CBA results to changes in input assumptions annuitised values of £50 per MWkm and £200 per MWkm were also investigated by the GSR-009 group.
- 4.424 The CMP213 Workgroup discussed the consistency of these values with those used in the TNUoS charging model (i.e. the Expansion Constant and Expansion Factors) in the context that some of the GSR-009 outcomes were being proposed to be used for TNUoS charging purposes.
- 4.425 The Expansion Constant (and Expansion Factors used in the TNUoS charging methodology are updated at each Transmission Price Control Review and increased by RPI in the interim period. As such, the existing Factors will not have been updated since 2007, during which time capital costs are known to have risen above inflation. The annuitised values currently used (2012/13) in NGET's area for the TNUoS charging calculation are shown in Table 6, below

Technology	Value relative to 400kV OHL	Unsecured value in £/MWkm	Security Factor	Secured value in £/MWkm
400kV OHL	1	£11.724	1.8	£21.103
275kV OHL	1.14	£13.365	1.8	£24.075
132kV OHL	2.80	£32.827	1.8	£59.089
400kV Cable	22.39	£262.5	1.8	£472.5
275kV Cable	22.39	£262.5	1.8	£472.5
132kV Cable	30.22	£354.299	1.8	£637.738

**Table 6 – Existing expansion factors for NGET area**

- 4.426 In calculating the incremental cost of transmission at a node on the transmission network, the Transport Model adds 1MW to that node and removes 1MW from the notional centre of the transmission network. The path that the incremental 1MW takes in various proportions through various transmission technologies (all with unique costs) over the distance to the centre of the transmission network sets the locational signal.
- 4.427 The following diagram, Figure 43, illustrates the relative costs used in the Transport and Tariff model and within the NETS SQSS CBA. Some Workgroup members believe that the same range of the Annuitised Unit Costs should be used in both the NETS SQSS and Charging methodologies to harmonise the basis for planning transmission investments and charging Users for use of the networks.

<sup>6</sup> Review of Required Boundary Transfer Capability with Significant Volumes of Intermittent Generation, Ref. GSR-009, 11 June 2010, Appendix 5, p. 55



**Figure 43 – Illustrative spread of charging and SQSS annuitised cost assumptions**

- 4.428 The main sources of variation between these costs are the aforementioned misalignment due to the period over which costs are updated in the TNUoS charging methodology and, more importantly, the marginal nature of the cost assumptions used for GSR-009 (i.e. what is the cost of the next transmission technology that is likely to be used; including HVDC, which is not incorporated into the current TNUoS charging methodology) versus the average nature of the cost assumptions used for TNUoS charging (i.e. dictated by the existing transmission technologies on the network and the path of the incremental 1MW).
- 4.429 The Workgroup found that although differences between the NETS SQSS GSR-009 cost of transmission and those in the TNUoS charging model were evident, the reasons for these differences were such that they did not invalidate the use of the GSR-009 conclusions (i.e. background scaling factors for generation) in the Transport model of a potential future TNUoS charging methodology.
- 4.430 In addition, the Workgroup concluded that a review of transmission unit costs was not within the scope of this CMP213 Modification Proposal.

#### **(xi) Sharing potential alternative 11 - Alternative Zoning**

- 4.431 In order to promote stability in the charging signal TNUoS tariffs are calculated on a zonal, rather than nodal, basis. For demand, the zones are fixed to historical GSP Groups (equivalent to the 14 GB DNO areas). For generation this is done by comparing nodal marginal km arising from the Transport model with those at other geographically and electrically proximate nodes. Generation TNUoS zones are subsequently created by grouping those nodes that are both geographically proximate and no more than +/- £1/kW apart. A weighted average of nodal marginal km is subsequently taken to calculate the zonal TNUoS tariff.
- 4.432 Currently there is only one single set of marginal kms against which this zoning process takes place and all generators regardless of technology type are exposed to this tariff. The Original proposal sets out a dual background (Peak Security and Year Round) approach to setting two elements of the overall TNUoS tariff. In addition it proposes that intermittent generation are is not exposed to the Peak Security element. As all generators are exposed to the Year Round element of the TNUoS tariff, and due to the fact that this element represents over 80% of the total marginal kms, the Original proposes that the generation zoning process is done on this background.
- 4.433 There are many potential alternative approaches to generation TNUoS zoning. Two of the primary considerations when deciding on an approach should be the year on year stability of TNUoS tariffs against the cost reflectivity under one approach versus another.
- 4.434 In one potential alternative approach, generation TNUoS zones could be aligned with GSP Groups (i.e. with the 14 demand (DNO) zones). This



would likely increase the (charging) year on (charging) year stability of wider generation TNUoS tariffs, but would have a trade-off in reduced cost reflectivity associated with having less granularity in the TNUoS charging signal.

- 4.435 A second potential alternative would be to zone generation TNUoS on the total marginal kms arising out of both the Peak Security and Year Round backgrounds, rather than simply those from the Year Round background.
- 4.436 Whilst the Workgroup discussed the above potential alternative approaches to generation zoning TNUoS tariffs, no specific potential alternative was proposed.

#### **Other issues covered**

- 4.437 The calculation of TNUoS tariffs for both Short Term TEC (STTEC<sup>7</sup>) and Limited Duration TEC (LDTEC<sup>8</sup>) currently utilises the final annual TNUoS tariff expressed in £/kW. Although different elements of the generation TNUoS charge exist at the moment, these are charged against the same chargeable MW capacity (TEC), and so can be simply added to reach the final TNUoS tariff utilised.
- 4.438 However, the proposed solution under the Original proposal will result in generation TNUoS charges that are no longer solely based upon the product of TEC and a tariff (e.g. the use of a load factor in the Year Round charge). This therefore raises the potential need for a consequential CUSC Modification Proposal to review the calculation of STTEC and LDTEC TNUoS tariffs. Such a modification may also need to look at the chargeable capacity (MW) applied in the STTEC/LDTEC charge calculation, which may need to be considered in light of the changes made to the chargeable capacity under the Original CMP213 proposal.
- 4.439 Nevertheless the Workgroup did note that the relevance, and therefore use, of these transmission access products had reduced significantly since the introduction of a connect and manage approach to transmission network access and that this issue was likely to be minor as a result.

**Q4: Do you consider that the Workgroup has adequately set out and considered all relevant options and potential alternatives on the *sharing* aspect of this modification proposal? If not, what other options would you like the Workgroup to consider and why?**

**Q5: What are your overall views on how best to reflect the differential impact of generators with distinct characteristics on incremental network costs into the TNUoS charging methodology?**

---

<sup>7</sup> <http://www.nationalgrid.com/uk/Electricity/Codes/systemcode/stfirm/>

<sup>8</sup> <http://www.nationalgrid.com/uk/Electricity/Codes/systemcode/ldtec/>

### Introduction

- 5.1 Currently the element of the TNUoS charging model that calculates nodal incremental costs does this using a set of input data including nodal generation and demand, transmission circuits and their characteristics (length, impedance, voltage and whether cable or overhead line). This is called the Transport model.
- 5.2 The Transport model then uses the DCLF ICRP transport algorithm to derive a resultant pattern of power flows based on the transmission network impedance for both a 'base case' and 'incremental 1MW' scenario. This is used to calculate the incremental network MWkm for 1MW of generation and demand (equal and opposite to generation) for a given node on the transmission network.
- 5.3 The Transport model employs the use of transmission circuit length expansion factors to reflect the difference in cost between:
- i) AC cable and overhead line routes; and
  - ii) 132kV, 275kV and 400kV AC circuits
- 5.4 As the Transport model expresses cost as marginal kilometres (irrespective of transmission technology) and uses 400kV overhead line as the base technology, some account needs to be taken of the fact that investment in other transmission technologies is more expensive. This is done by effectively 'expanding' these more expensive transmission circuits by the relevant circuit expansion factor, thereby producing a larger marginal kilometre to reflect additional cost.
- 5.5 In order to accommodate increasing volumes of new generation connecting to the transmission network, the Transmission Owners have proposed the use of High Voltage Direct Current (HVDC) circuits<sup>9</sup> that parallel the AC transmission network and would be routed offshore in order to avoid planning and consenting constraints (and associated timescales) onshore. These HVDC transmission circuits are not currently catered for in the Transport model.
- 5.6 In order to incorporate parallel HVDC transmission circuits into the TNUoS charging calculation two main issues need to be addressed:
- i) treatment of flows in the DC load flow element of the charging model, in light of the inherent controllability of power flows through an HVDC transmission circuit; and
  - iii) calculation of the expansion factor (i.e. relative unit cost) for these HVDC transmission circuits.
- 5.7 The pattern of power flows set out in paragraph 5.2 is a key aspect of setting the locational differential between the TNUoS charging zones. With existing AC transmission technologies, this pattern is dictated by the relative impedance of the circuits that comprise the transmission network. This impedance is an inherent physical characteristic of an electricity conductor.
- 5.8 The Original proposal would treat power flow down a parallel HVDC transmission circuit in the Transport model on a simplifying assumption due

---

<sup>9</sup> One example can be found at: [www.westernhvdlink.co.uk](http://www.westernhvdlink.co.uk)

to the controllable nature of these circuits relative to power flows on the AC transmission network, which are dictated solely by the impedance of a transmission circuit that is fixed.

- 5.9 This simplified approach would model HVDC transmission circuits that parallel the AC transmission network as a pseudo-AC circuit, thus requiring the calculation of a notional impedance for the HVDC circuit. This would be done by first calculating a base case flow down the HVDC circuit, which would subsequently be used to calculate the notional impedance for it in the Transport model.
- 5.10 The base case flow down the HVDC transmission circuit would be calculated as a ratio of power flows to circuit ratings across a transmission network boundary 'crossed' by the HVDC circuit. This approach would calculate a desired power flow for the HVDC circuit on each transmission boundary that the link 'crosses' and then average this flow across those multiple transmission boundaries.
- 5.11 In terms of the calculation of the expansion factor for an HVDC transmission circuit, the Original proposal would do so on a transmission circuit specific basis and would include both sub-sea cable and the HVDC converter station costs. This approach is consistent with offshore (OFTO) situations, where both costs are implicitly included in the expansion factor calculation for HVDC.

### Inclusion of HVDC links

- 5.12 The Workgroup were required to consider the issues raised under this aspect of the CMP213 Modification Proposal and were asked to report on the following specific issues in line with/in addition to those set out in the Authority's SCR Direction by the CUSC Panel:
  - a) how often the parameters associated with the proposed approach should be updated (e.g. annually, every 4 years, every 8 years)
- 5.13 In the second meeting the Workgroup considered both the terms of the SCR Direction and the specific request from the CUSC Panel and compiled a single list of options and potential alternatives to be investigated from the outset. These are explored further below.

### Initial scoping of the Original

- 5.14 The Workgroup agreed the areas to be considered for the HVDC aspect of the Original proposal could be summarised as:

Considerations from the Direction	Potentials changes to Original
a) Whether the cost of HVDC converter stations should be included in the expansion factor calculation	i) Remove all converter station costs from the calculation
	ii) Remove some converter station costs from the calculation
	iii) Treat HVDC cost as onshore AC transmission technology cost when calculating the expansion factor

### Areas for development of Original and Potential Alternatives

- 5.15 The Workgroup also discussed further areas where the Original could be developed not highlighted by the Direction or where the potential alternatives could be developed and discussed each of these in turn.

Potential Alternatives	
i.	Review the overhead factor (i.e. 1.8%) used when annuitising the capital cost in the calculation of the HVDC expansion constant
ii.	Calculated the 'desired flow', and hence notional impedance, by balancing flows across the single most constrained transmission boundary rather than all the transmission boundaries the HVDC link 'crosses'
iii.	Review security factor calculation in light of long (MWkm) HVDC links comprised of single transmission circuits that parallel the AC transmission network

### Discussion on the Original and potential alternatives

- 5.16 The following section presents the Workgroup detailed discussion on the issues identified above.

**a) Whether the cost of HVDC converter stations should be included in the expansion factor calculation**

- 5.17 As set out above, the Original proposal would include all the costs of an HVDC converter station into the expansion factor calculation. This is deemed to be consistent with the approach taken for offshore (OFTO) transmission TNUoS tariffs.

- 5.18 The Workgroup investigated alternatives to this approach.

- 5.19 In doing so they noted that there are basically two cost elements associated with HVDC transmission circuit, namely (i) the cost of the sub-sea cables and (ii) the cost of the onshore converter stations that converts the electrical current between AC and DC so that it can be transferred along the sub-sea cables. The Workgroup considered how these two cost elements could be included within the Improved ICRP solution.

**a) i) Remove all converter costs from the calculation**

- 5.20 The Workgroup discussed a potential alternative where 100% of the cost of the sub-sea cables would be included in the expansion factor and 100% of the cost of the onshore converter stations would be excluded from the expansion factor calculation on the basis that some members of the Workgroup believed that the HVDC converter station costs should be treated as fixed costs.

- 5.21 The reason some members came to this view is that the locational element of the ICRP charging methodology is underpinned by a MWkm (distance related) methodology with fixed elements, such as transformers, being excluded from the calculation of the locational element of the tariff and instead being recovered through the residual element.

- 5.22 These members believed that HVDC converter stations exhibit the same traits as other fixed elements of the transmission system. For example, that they have broadly the same function as transformers/substations in that they effectively link different elements of the transmission system. In addition and they can also provide system services (specifically reactive compensation and post-fault power flow redirection).

- 5.23 On this basis these members believed that including any fixed costs in the calculation of expansion factors would cause a distortion in the locational element of the TNUoS tariff. They believed that this is particularly the case with HVDC transmission circuits as the converter station costs are such a significant proportion of the total cost. They were of the view that including fixed costs in the calculation of the HVDC transmission circuit expansion factor will cause a distortion in the locational element of the TNUoS tariff and would make it inconsistent with the existing TNUoS charging methodology expansion factors calculations.
- 5.24 One Workgroup member cited an example, using numbers in the Project Transmit Technical Working Group Report and taking the cable cost as including the converter station costs then the cost of the Western 'bootstrap' HVDC transmission circuit is £1bn, the capacity 2GW and the distance 370km. The cost, in this example, of the converter stations is £550m. In a distance related model, it would be expected that if the distance halved, the effective cost of the cable would reduce in proportion. However, including the converter station costs means that when the cable length is halved, the effective cost in £/MWkm in the model would increase by 55%.
- 5.25 Some Workgroup members believed that this could not be a proper reflection of the locational element of the costs. That can only be reflected by excluding the costs of the converter stations from the calculation of the cable expansion factor and allocating the converter station costs to the residual element of TNUoS tariffs.
- 5.26 The Proposer noted that, as the Original Proposal was proposing to calculate HVDC expansion factors on a circuit specific basis, the issue of fixed costs not altering with distance would not be an issue (i.e. each circuit would have a fixed distance). Indeed, the Proposer believed that in order to use HVDC cable technology converter stations are necessary, that these converter stations add to the cost of this transmission technology and as such should be included in the locational signal so that transmission network Users can properly take account of the cost of transmission when deciding to locate their generation plant.
- 5.27 Some Workgroup members believed that there are wider issues in relation to expansion factor calculations. Reinforcement by HVDC circuit is taking place for the benefit of Great Britain customers and generators. Using HVDC is driven by the UK and Scottish Governments climate change obligations and targets together with the difficulties in getting planning for overhead transmission lines. However, these members believed that this should not result in excessive costs being allocated to those generators on one end of the HVDC transmission circuit. In particular, these members believed that it should not be for those generators to pick up the fixed costs of reinforcement through a locational tariff. Indeed, without the removal of these fixed costs, the resulting TNUoS charges may prevent the investment in the very generation that the HVDC cables are intended to serve.
- 5.28 Others in the Workgroup believed that the costs of the HVDC converter stations represented the actual costs of investment in that transmission technology and therefore did not consider that these costs could be considered as excessive. These members were of the view that, if a potential investment in generation in one area of the transmission network was made uneconomic by TNUoS tariffs, that this simply represented a project that was not viable when including the cost of delivering their product to market. They believed that, this may represent the best outcome for consumers. Nevertheless, some Workgroup members were of the view that this could prevent a number of GW of low carbon generation from contributing to UK sustainability targets.

**a) ii) Remove some converter costs from the calculation**

5.29 The Workgroup identified 2 possible alternatives for the removal of a portion of the HVDC converter station costs from the expansion factor calculation:

- i) Remove a percentage of the costs based on those elements of the converter station that are similar to elements of the AC transmission network that are currently not included in the locational signal (such as substation equipment); and/or
- ii) Remove a portion of the costs based on the similarity between the power flow redirecting capability of HVDC converters and that of Quadrature Boosters (QBs) that are currently not included in the locational signal;

i) Remove a percentage of the HVDC converter station costs based on elements similar to AC substations

5.30 The TNUoS charging methodology currently does not include many of the costs of the transmission network that do not vary with distance, such as substation costs, in the calculation of expansion factors. On this basis, and the fact that a proportion of HVDC converter station costs are related to AC substation equipment, the Workgroup believed that a possible alternative to the Original proposal could be to remove those cost elements from the calculation of the expansion factor. This approach would maintain the DC elements, such as the switching equipment, required for the use of DC cables.

5.31 The Workgroup recognised that one of the difficulties with this approach was that there have not yet been any HVDC transmission links established to date and that these projects were often procured on a turn-key basis with minimal cost breakdown.

5.32 Nevertheless, the Workgroup did manage to find a breakdown of costs for a typical HVDC converter station from Cigre paper 186, working group 14.2 (June 2001). The cost breakdown from this paper is reproduced in Table 7, below.

Breakdown of Typical HVDC Converter Station costs			
	Cost Elements	Proportion of Cost	Characteristic (AC/DC)
(1)	DC switchgear	6%	DC
(2)	Valve group	22%	DC
(3)	Control, Protection, Comms	8%	Shared
(4)	Converter transformer	22%	AC
(5)	AC switchboard and filters	9%	AC, but filter DC
(a)	Civil, mechanics and works	13.5%	split in proportion to (1)-(5)
(b)	Auxiliary power	2.5%	
(c)	Project engineering and admin	17%	

**Table 7 – Cost breakdown of a 'typical' HVDC converter**

5.33 Having considered the numbers presented in Table 7 above, the Workgroup noted that approximately half the cost of a typical HVDC converter station is akin to AC substation elements not included in the locational (TNUoS) signal throughout the rest of the transmission network.



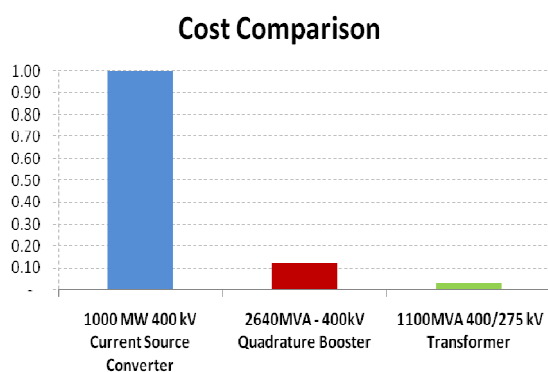
- 5.34 As a result, some Workgroup members believed that it may be reasonable to take this into account when calculating the expansion factor for a HVDC circuit that parallels an AC network.
- 5.35 Depending on the specific application of an HVDC transmission circuit, in particular the length of the cable, the Workgroup considered that converter station costs were likely to comprise somewhere between 30% to 50% of the total costs of the HVDC link. In this case, removing half the cost (of the converter station) from the expansion factor calculation would reduce the expansion factor by between 15% and 25%.

ii) Remove a percentage of the HVDC converter station costs based on controllability similar to QBs

- 5.36 The Workgroup also considered the controllability of HVDC transmission circuits and the potential benefits that may be afforded to the System Operator as a result of this controllability. Some in the Workgroup believed that these benefits should be reflected in a reduction of the expansion factor.
- 5.37 After some debate, the Workgroup agreed that, for Current Source Converters, these benefits are likely to be somewhat nebulous, difficult to quantify and may result in a lower BSUoS tariff, but that they were unlikely to be relevant to the incremental cost of transmission capacity upon which TNUoS charges are based and expansion factors are calculated.
- 5.38 Some members believed that this was not necessarily the case for Voltage Source Converters, as planned for use in some island connections. This is outlined further in the islands aspect of this proposal.
- 5.39 One item of transmission technology that does allow the System Operator to better utilise existing transmission network capacity is the Quadrature Booster (QB), which can be used to redirect power flows on transmission circuits. As such, this benefit could be considered to be relevant to the incremental cost of transmission capacity. However, currently QBs are not factored into the locational signal.
- 5.40 In April of 2006 National Grid undertook a review of the elements included in the incremental cost of capacity as part of GB Charging Condition 210. This review considered the addition of QBs and reactive compensation devices into the calculation of locational differentials.
- 5.41 At that time National Grid concluded that, due to the way in which they redirect power flow on the transmission system, rather than provide additional transmission capacity, the addition of QBs was likely to be subjective. Condition 2 proposed that the potential increased cost reflectivity of inclusion of QBs in the Transport model was outweighed by the increased subjectivity and complexity that this would introduce.
- 5.42 In addition to providing transmission capacity, HVDC converter stations can also be used to redirect power flows and in this sense are similar to QBs. Some Workgroup members believed that as QBs were not included in the locational signal, the equivalent cost should also be removed from the HVDC expansion cost calculation.
- 5.43 The relative cost of a representative HVDC versus a QB and a transformer was presented to the group by National Grid and is shown in Figure 44, below.

---

<sup>1010</sup> <http://www.nationalgrid.com/uk/Electricity/Charges/gbchargingapprovalconditions/2/>



**Figure 44 – Relative cost of CSC HVDC, QBs and Transformers**

- 5.44 This cost comparison indicates that if QB costs were to be removed from the HVDC converter station cost element, that this would likely amount to the order of a 10% cost reduction to the converter station (i.e. 3% to 5% of the total HVDC link cost).
- 5.45 Having considered the two potential alternatives above, the Workgroup concluded that there were potential alternatives that would remove either 10% or 50% of the total converter station costs from the overall HVDC circuit expansion factor, depending on the logic used for justifying this cost removal. Some Workgroup members were of the view that both a 10% and 50% removal of costs would be justified.

**a) iii) Treat HVDC cost as onshore AC transmission technology cost when calculating the expansion factor**

- 5.46 Some of the Workgroup believed that the expansion factor calculation for HVDC transmission circuits should be based on actual HVDC unit costs in order to be cost reflective.
- 5.47 One Workgroup member cited several public documents setting out the cost of the Western HVDC ‘bootstrap’ transmission circuit:
- 1) the joint statement from National Grid and Scottish Power in July 2012 concerning the Western HVDC ‘bootstrap’ and, in particular, the statement “....that the cost of onshore reinforcement would be similar to that of an offshore HVDC alternative<sup>11</sup>”; and
  - 2) the joint DECC / Ofgem ENSG report ‘Our Electricity Transmission Network: A Vision For 2020’ (February 2012) and, in particular, that the onshore circuits “....did not represent the most economic solution. The total length of the new circuits would be in excess of 600km; this resulted in a total project cost that was higher than the undersea HVDC option.”<sup>12</sup>
- 5.48 Some of the Workgroup believed, in the case of the Western HVDC link, that it should be treated in exactly the same way as the equivalent parallel (onshore) AC 400kV transmission circuits in the TNUoS charging methodology.
- 5.49 It was appreciated by the Workgroup that this approach would apply the existing expansion constant (i.e. an expansion factor of 1) to the HVDC transmission circuit, and that this would ultimately result in a reduction in tariffs in TNUoS zones north of the HVDC transmission circuit.

<sup>11</sup>Planning Statement Western Link July 2012, paragraph 2.5.2

<sup>12</sup> Page 70 of this report



- 5.50 These Workgroup members believed that to do otherwise would be to unduly discriminate against certain Users as they would be exposed to a higher TNUoS charge, even though the actual cost and MW capacity of the two comparable links (one 400kV AC onshore / one 600kV HVDC offshore) were similar. These members considered that in addition to being discriminatory it would also not be cost reflective given that both the cost and capacity were similar, but one option (the onshore AC) would, if built, have resulted in a substantially lower TNUoS charge than the other option (sub-sea HVDC).
- 5.51 The Workgroup discussed the differences between a sub-sea HVDC transmission link and the alternative (onshore) 400kV AC transmission reinforcements in terms of capacity provided, costs and timescales. Not all members of the Workgroup were convinced that both cost and network capacity provided by the onshore AC and sub-sea HVDC options were comparable.
- 5.52 One significant difference identified by some Workgroup members was the significant annual constraint costs that would be incurred during the planning delays expected to occur during the building of the aforementioned onshore alternative transmission system reinforcement.
- 5.53 In particular, based on recent experience with long distance onshore 400kV overhead transmission line construction, it is generally anticipated that building an equivalent onshore transmission link could take more than 10 years, from concept to commissioning. This was likely to be halved for an equivalent HVDC transmission link, leading to a period of time where such an HVDC link provided relief, from constraint costs, compared to the equivalent onshore link. In the view of some Workgroup members this should result in a discount, on the HVDC TNUoS charge, to reflect the constraint costs saved (over the period of time in question). However, other members of the Workgroup noted that constraint costs were not charged locationally.
- 5.54 A potential alternative where a sub-sea HVDC transmission circuit is treated as if it were (onshore) 400 kV transmission technology was deemed plausible by some members of the Workgroup, but was not widely supported by Workgroup members.

**Q6: Do you believe that the Workgroup has considered all relevant options and potential alternatives for how the expansion factor (i.e. unit cost) for an HVDC circuit paralleling the AC network should be calculated for inclusion in the TNUoS charging calculation? If not, please provide suggestions with an associated justification.**

### Potential Alternatives

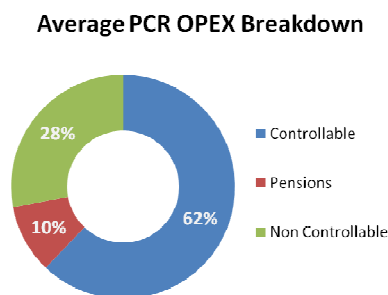
**i) Review the overhead factor (i.e. 1.8%) used when annuitising the capital cost in the calculation of the expansion constant**

- 5.55 When annuitising capital costs of transmission assets to calculate the expansion constant and expansion factors, the TNUoS charging methodology utilises a weighted average cost of capital assumption of 6.25% and a transmission asset life of 50 years to calculate an annuity factor of 0.066.
- 5.56 In order to account for operational expenditure an additional overhead factor is calculated at the start of each Transmission Price Control Review period by taking the average annual operational expenditure over the period and dividing by the gross asset value. Currently this value is set at

1.8% and applies equally across all transmission technologies through the annuity process.

5.57 Despite the global nature of this value, the Workgroup discussed whether it would still be appropriate for it to be applied to an HVDC transmission link with sub-sea cables, given the differences with existing AC transmission technology. The investigation began with consideration of what proportion of the operational expenditure included in the overhead factor calculation would be transmission asset specific.

5.58 Figure 45, below, shows the approximate break down of operational costs over the next (RIIO-1) Transmission Price Control Review period. The Workgroup considered that only those costs that were controllable could change on an (transmission) asset by asset basis.

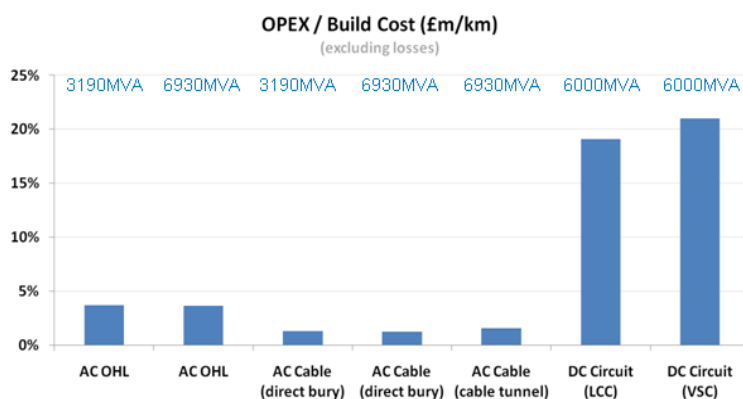


**Figure 45 – Average PCR breakdown of OPEX**

5.59 The Workgroup also considered further the breakdown of controllable costs into (i) direct OPEX, (ii) closely associated indirect costs and business support costs, (iii) Critical National Infrastructure and (iv) Innovation Funding Initiative costs. Of these costs, 40% were direct OPEX, and it is these costs that are transmission asset related.

5.60 From the above, the Workgroup concluded that approximately 25% (i.e. 40% of 62%) of the 1.8% overhead factor could vary for different transmission asset types.

5.61 Using the Parsons Brinkerhoff Transmission Costs report (2012)<sup>13</sup>, the Workgroup also investigated how lifetime operational costs vary for the different transmission assets used. Figure 46, below, illustrates the differences of lifetime OPEX over build costs for various transmission technologies.



**Figure 46 – Lifetime OPEX/Build Cost for various transmission asset types**

<sup>13</sup> [www.theiet.org/factfiles/transmission.cfm](http://www.theiet.org/factfiles/transmission.cfm)

5.62 From the above Figure 46 the Workgroup concluded that, despite variances in lifetimes for the transmission assets considered, the differences were such that the overheads for (offshore) HVDC transmission circuits were likely to be higher than those of other transmission assets such as (onshore) overhead lines and underground cables.

5.63 The Workgroup discussed the benefits of simplicity and stability arising from the use of a single overhead factor for all transmission assets and concluded that the minor increase in cost reflectivity associated with a more specific treatment did not warrant consideration of a potential alternative in this area.

**ii) Calculate the 'desired flow', and hence impedance, by balancing flows across the single most constrained transmission boundary rather than all the transmission boundaries the circuit crosses**

5.64 As set out in paragraph 5.10, above, the Original proposal would calculate the base case flow down the HVDC transmission circuit as a ratio of power flows to circuit ratings across a transmission network boundary 'crossed' by the HVDC circuit. This approach would calculate a desired power flow for the HVDC circuit on each transmission boundary that the circuit 'crosses' and then average this flow across multiple transmission boundaries.

5.65 The Workgroup appreciated that the calculation of an impedance in order to model the HVDC transmission circuit as a pseudo-AC transmission circuit was not an exact science due to the controllable nature of the HVDC circuit. In addition, the Workgroup appreciated that this impedance calculation would have a significant impact on the proportion of the incremental MW that would use the HVDC circuit. As the route of this incremental 1MW is used to calculate the locational signal, the potential impact on TNUoS tariffs of this calculation was clear.

5.66 As a potential alternative to calculating the base case flows across individual transmission boundaries and subsequently averaging the flows across all these boundaries that the HVDC transmission circuit 'crosses' in order to calculate the impedance, the Workgroup considered simply calculating the base case flows on the single most constrained transmission boundary that the HVDC circuit reinforces.

5.67 The logic behind this approach was that it is this most constrained transmission boundary that would limit the additional network capacity provided by the installation of the HVDC circuit on the overall transmission system.

5.68 The impact of calculating base case flows on a single, rather than multiple transmission boundaries, would be a reduction in the impedance (i.e. the base case flow on the HVDC transmission circuit would increase) and a resultant increase in incremental flows down the HVDC link. The Workgroup appreciated that this would increase the locational differentials relative to the multiple transmission boundary approach proposed in the Original.

**Q7: Do you believe that the Workgroup has satisfactorily considered all the options and potential alternatives for how an HVDC circuit paralleling the AC network should be modelled in the DC load flow element of the TNUoS charging calculation? If not, what other options would you like the Workgroup to consider and why?**

**iii) Review security factor calculation in light of long (MWkm) HVDC transmission circuits comprised of single circuits that parallel the AC transmission network**

- 5.69 Currently, the locational onshore security factor for the wider transmission network is derived by running a secure DCLF ICRP transport study based on the same market background as used in the DCLF ICRP Transport model. This calculates the nodal marginal costs where peak demand can be met despite the Security and Quality of Supply Standard (NETS SQSS) contingencies (simulating single and double circuit faults) on the transmission network.
- 5.70 The calculation of secured nodal marginal costs is identical to the process outlined above except that the secure DCLF study additionally calculates a nodal marginal cost taking into account the requirement to be secure against a set of worse case contingencies in terms of maximum flow for each transmission circuit.
- 5.71 The secured nodal cost differential is compared to that produced by the DCLF ICRP Transport model and the resultant ratio of the two determines the locational security factor using the Least Squares Fit method.
- 5.72 The prevailing security factor for the wider transmission network is currently 1.8 and is based on an average from a number of studies conducted by NGET to account for future transmission network developments. The security factor is reviewed for each Transmission Price Control Review period and fixed for the duration of that Review period.
- 5.73 Some Workgroup members believed that the introduction of a single circuit HVDC transmission circuit (i.e. connected via a single bi-pole) warranted a review of whether it was still cost reflective to apply a security factor of 1.8 for this part of the transmission network.
- 5.74 The Workgroup discussed the fact that if HVDC were to be introduced into the existing secured DCLF calculation that it would be unlikely to materially affect the outcome if a global factor remained.
- 5.75 One Workgroup member considered that if the cost of the HVDC transmission circuit was to be multiplied by 1.8 in the TNUoS tariff calculation, that this should be done on the unit cost of a double transmission circuit rather than the single transmission circuit that was planned.
- 5.76 This member pointed out that the reverse had been done for single transmission circuit connections when local transmission circuit charging was introduced.
- 5.77 Nevertheless it was the Workgroup's view that the unit cost of a double circuit HVDC transmission circuit was likely to be similar to that of a single transmission circuit link. Whereas onshore transmission circuits would see a cost difference due to savings in towers, etc., a second HVDC circuit would likely also require an additional converter station and would hence likely have a very similar unit cost.
- 5.78 As a result, no potential alternatives were considered by the Workgroup in this area.

**Q8: Do you consider that the Workgroup has adequately set out and considered all relevant options and potential alternatives on the HVDC circuit aspect of this modification proposal? If not, what other options would you like the Workgroup to consider and why?**

**Q9: What are your overall views on how best to incorporate HVDC circuits that parallel the AC network into the TNUoS charging methodology?**

### Introduction

- 6.1 CMP 213 seeks to develop a methodology for calculating cost reflective TNUoS charges for transmission spurs (connecting generation and demand) and comprised of transmission network technology not included in the expansion factors set out in clause 14.15.47 and 14.15.49 of the CUSC such as those which may be established between the Scottish mainland and the Scottish islands of Western Isles, Orkney and Shetland.
- 6.2 Whilst charging for island connections comprised of sub-sea cables is not currently codified in the CUSC, it was the subject of a charging consultation<sup>14</sup> published in November 2009 that proposed the use of specific expansion and security factors on the basis that these connections to the transmission network would be classed as local transmission assets under the current definition.
- 6.3 In order to calculate cost reflective TNUoS charges for this type of sub-sea transmission circuit configuration the Original proposal also addressed how the expansion and security factors should be calculated for the underground and subsea transmission technologies proposed for island connections and not included in the TNUoS charging methodology.
- 6.4 As outlined above for HVDC transmission circuits, the TNUoS charging methodology incorporates the unit cost of various transmission technologies by calculating the cost of a given technology relative to the cost of a 400kV (AC) overhead transmission line. This allows for the calculation of a multiplier, known as an expansion factor, which is used in the Transport model to calculate the locational signal within TNUoS charges.
- 6.5 For transmission spurs, such as those connecting Scottish islands, the Original proposes to calculate new expansion factors for each type of transmission network technology planned. Where such circuits are comprised of HVDC technology, the methodology would be consistent with that for HVDC transmission circuits paralleling the AC transmission network.
- 6.6 The Original proposal would not alter the definition of a MITS node (i.e. connected via > 4 transmission circuits or 2 transmission circuits + a Grid Supply Point). The consequence is that, with the connections currently proposed, some circuits connecting islands to the mainland would be classed as 'local' and others would be classed as 'wider'.
- 6.7 In addition, the Original addresses circumstances where a reinforcement creates a MITS node but where a significant proportion of the transmission spur has no redundancy, but is still deemed to be part of the wider transmission network for TNUoS charging purposes. Rather than apply the

---

<sup>14</sup> <http://www.nationalgrid.com/NR/rdonlyres/5492DC2B-5A82-478A-8673-0EBAC44D2C69/39267/GBECM20Consultationv11.pdf>

current GB average cost of security (using a Security factor of 1.8), the Original proposal applies the actual level of security (1.0). It does this by adjusting the length of the relevant portion of the transmission circuit in the Transport model to compensate by multiplying its actual length by 1/(Locational Security Factor).

- 6.8 As the sharing aspect of the Original proposal assumes that sharing occurs implicitly across the wider transmission network, generators connected to nodes on islands classed as part of the Main Interconnected Transmission System (MITS) for TNUoS charging purposes would pay a two part tariff, including the sharing factor (based on their plant’s annual load factor), associated with this aspect of the Original proposal.
- 6.9 For the avoidance of doubt, the Original proposal assumes that no sharing occurs on transmission circuits classed as local, based on how these types of circuits are planned in the NETS SQSS.
- 6.10 The Workgroup were required to consider the issues raised under this aspect of the CMP213 Modification Proposal and were asked to report on the following specific issues in addition to those set out in the Authority’s SCR Direction by the CUSC Panel:

**Inclusion of Island Connections**

- a) ensure that the charging solution is commensurate with transmission access rights;
- b) consider appropriate approach for islands that form part of integrated offshore networks; and
- c) review the application of the expansion factor in the tariff calculation.

6.11 In the second meeting the Workgroup considered both the terms of the SCR Direction and the specific request from the CUSC Panel and compiled a single list of options and potential alternatives to be investigated from the outset. These are explored further below.

**Initial Scoping of the Original**

6.12 The Workgroup agreed the areas to be considered for the sharing aspect of the Original proposal could be summarised as:

Considerations from the Direction	Potentials changes to Original
a) Whether Islands classed as ‘wider’ for charging purposes should have a 2 part wider TNUoS tariff as determined by the sharing aspect of the Original proposal	i) Islands classed as wider do not have a two part TNUoS tariff
b) Whether Islands classed as ‘local’ for charging purposes should have TNUoS tariffs consistent with the current existing methodology for local circuit and local substation tariffs	i) Review local/wider definitions and perhaps consider an alteration/addition to accommodate Scottish Islands (e.g. look at MITS)



	ii) Apply sharing to local circuits incl. Scottish Islands
c) Whether the expansion factor should be calculated in a generic manner across all Islands or whether it should be island link specific	i) Across all islands regardless of transmission technology
	ii) One generic factor for AC, and one for DC
	iii) Island (i.e. not link) or Island Group <sup>15</sup> specific
d) Whether, for islands classed as ‘wider’, the global locational security factor should be used without further modification or whether any lack of redundancy should be reflected in the expansion factor calculation	i) Yes; apply 1.8 for two circuit cases
	ii) Yes; some other factor between 1 and 1.8
e) Whether the expansion factor calculation for radial island links comprising HVDC technology should be the same as that for HVDC links that parallel the (onshore) AC transmission network	i) Yes (on all elements of HVDC options)
f) Whether an anticipatory application of the MITS definition to islands is appropriate and how this could be done.	i) Yes; just to islands
	ii) Yes; to everything

### Areas for development of Original and Potential Alternatives

6.13 Given the extensive nature of the SCR Direction in this area, the Workgroup could not think of any further areas where the Original could be developed not already highlighted by the Direction or where any additional potential alternatives might be developed.

### Discussion on the Original and Potential Alternatives

6.14 This section covers the Workgroup discussions on each of the individual issues above. It does so by taking each of six main considerations from the SCR Direction in turn, with each of the potential changes to the Original covered under these main considerations.

#### a) Whether Islands classed as ‘wider’ for charging purposes should have a 2 part wider tariff as determined by the sharing aspect of the proposal

6.15 The Original proposal applies the principles of sharing set out within it to all parts of the transmission network considered to be part of the Main Interconnected Transmission System (MITS); (i.e. ‘wider’); for TNUoS charging purposes. Implicitly this would also include island connections that are classed as ‘wider’ because they are part of the MITS.

<sup>15</sup> ‘Island Groups’, for the purposes of Workgroup discussions were considered to be those in Scotland, and in particular (i) the Western Isles (ii) Orkney and (iii) Shetland only.

- 6.16 In the calculation of a 2 part wider TNUoS tariff, the Original proposal uses the background assumptions set out within the NETS SQSS, which sets out minimum deterministic standards to which the TOs are required to plan their transmission networks in accordance with their Transmission Licences.
- 6.17 These backgrounds include a Peak Security background, where the need for transmission capacity is assumed to be driven by the capacity of generators that have a high probability of being available at times of peak demand and a Year Round background, which represents a pseudo-cost benefit analysis (CBA) approach to transmission capacity planning.
- 6.18 These two separate backgrounds are used by the Transport model to allocate incremental transmission network requirements to Peak Security and Year Round elements, ultimately leading to a two part TNUoS tariff. On the basis that the Year Round background is representative of the pseudo-CBA approach developed in the NETS SQSS, incremental requirements allocated to this element are deemed to be planned using a CBA approach to transmission network investment (i.e. involving a trade-off between investment costs and potential future operational costs).
- 6.19 Where a CBA approach to transmission network investment is used, the TO will seek to optimise network costs such that additional transmission capacity will only be added where the cost of installing that additional capacity is outweighed by potential future constraint costs. As a result, in the long term one would expect that the cost of reinforcing a given area of the transmission network would converge with the associated operational costs on average.
- 6.20 In terms of incremental transmission network requirements (i.e. on a MW by MW basis) as used in the TNUoS calculation, the Original proposal would continue to calculate incremental transmission network costs (i.e. the Long Run Marginal Cost – LRMC) using the impact of an incremental 1 MW in the Transport model for each of the two backgrounds (Peak Security and Year Round).
- 6.21 In order to differentiate between the impact on transmission network costs of generation plant with different characteristics, extensive analysis of the impact of these plant types on the operational costs in a given area of the transmission network was undertaken using National Grid's ELSI model (which is an Excel based model that was circulated to the Workgroup). The Proposer believed that this analysis demonstrated that there is a discernable relationship between a generator's annual load factor and its impact on incremental operational costs (i.e. the Short Run Marginal Cost – SRMC) of the transmission system.
- 6.22 Due to the aforementioned convergence of the LRMC and the SRMC on average over the long term where the transmission network is planned using the cost benefit analysis, the Original proposal introduces a generation sharing factor multiplier (using annual load factor) based on the results of the ELSI modelling to the Year Round element of the tariff calculated in the Transport model.



6.23 The Workgroup investigated potential alternatives to this approach.

**a) i) Islands classed as wider do not have a 2 part wider tariff**

6.24 As set out in the 'Discussions on Sharing' section, above, the Workgroup has also undertaken analysis that demonstrates a degradation of the relationship between a generator's annual load factor and incremental transmission network costs over the longer term as the capacity of low carbon generating plant (with zero and negative bid prices in the balancing mechanism) increases in a given part of the transmission network. This effect is most prominent on the extremities of the system.

6.25 The Original proposal accepts some degradation of the established relationship in the future in a small number of areas of the wider transmission network in order to maintain the benefits of a simple and transparent annual load factor based approach to reflecting the characteristics of different generators on incremental transmission network costs.

6.26 The Workgroup discussed whether this balance between cost reflectivity and simplicity of the TNUoS tariff calculation established within the mechanics of the Original proposal would be maintained for an example case where only wind generators were connected behind high unit cost island transmission links.

6.27 Some in the Workgroup believed that this balance would unlikely be maintained – i.e. that the application of an annual load factor based sharing factor to the Year Round element of the tariff under the Original was stretched too far for long, high unit cost (i.e. sub-sea) radial transmission spurs put in place for and utilised predominately for low carbon generation. However, there was disagreement on how to address this.

6.28 There was general agreement amongst Workgroup members that if island nodes were classed as MITS, there would be no justification for generators located on islands not to have a two part, Peak Security and Year Round, TNUoS tariff consistent with those connected to the MITS on the mainland, as per the Original proposal.

6.29 Whilst there was agreement around the application of the two part TNUoS tariff, there was concern amongst some in the Workgroup that the automatic application of the sharing factor to islands nodes which became classed as MITS (but that also shared many characteristics of a local circuit in terms of transmission network planning) may tip the balance between cost reflectivity and simplicity too far and in so doing undermine the Original proposal. In particular some believed that the relatively high cost of island sub-sea island transmission connections exacerbated the issue.

6.30 Some in the Workgroup believed that the potential alternatives to the Original being considered that take account of the diversity of generation plant types (in particular bid price diversity) in an area of the GB

transmission network (including, but not limited to, islands) or potential alternatives arising from the island specific analysis carried out by Heriot-Watt would deal with this problem sufficiently. These options are outlined in more detail in the sharing section, above.

- 6.31 In the context of the Original proposal, which would apply a generation sharing factor to the entire wider transmission network without consideration for diversity, the Workgroup looked at how this perceived imbalance between cost reflectivity and simplicity for high incremental cost island cases could be addressed.
- 6.32 Hence, the Workgroup also investigated potential alternatives to this approach, set out in (b) (i) and (ii) below.

**b) Whether Islands classed as ‘local’ for charging purposes should have tariffs consistent with the current existing methodology for local circuit and local substation tariffs**

- 6.33 Currently, for generation Users, the locational element of the TNUoS tariff is comprised of three separate components; (i) a wider component that reflects the costs of the wider transmission network (comprised of MITS nodes), and the combination of (ii) a local substation and (iii) a local circuit component that reflect the costs of the local transmission network.
- 6.34 Local components were introduced into the TNUoS charging methodology in 2009<sup>16</sup> in order to provide a cost reflective signal for transmission assets local to generation. This was to provide the appropriate charging signal to Users in choosing between differing levels of transmission investment through the NETS SQSS connection design provisions such, that these decisions (by the User) are made which result in the most economic and efficient outcome.
- 6.35 It was noted that in many instances Users are given a connection with a design variation (single circuit connection) by the Transmission Owner as the only practical/economic connection option (i.e. not all Users have a choice over the design of their local assets) and that in these cases it was not appropriate to apply the Global Locational Security Factor (1.8) applied to the remainder of the transmission network. This is addressed in the Original through an adjustment to the expansion factor, as set out above.
- 6.36 All generation that is subject to TNUoS and not connected directly to a Main Interconnected Transmission System (MITS) substation will have a circuit component to their local (TNUoS) charge. For charging purposes a MITS substation is defined as: (i) a Grid Supply Point (GSP) connection with 2 or more transmission circuits connecting at the substation; or (ii) more than 4 transmission circuits connecting at the substation.
- 6.37 Cost differentiation for wider transmission infrastructure for generation Users is currently managed via a zoning process whereby geographically

---

<sup>16</sup> GB ECM-11 ‘For the charging arrangements for Generator Local Assets’ Conclusions report; [http://www.nationalgrid.com/NR/rdonlyres/27F920CA-C678-4D91-A3D1-701E909BDAFB/28281/GBECM11ConcReport\\_final\\_HR.pdf](http://www.nationalgrid.com/NR/rdonlyres/27F920CA-C678-4D91-A3D1-701E909BDAFB/28281/GBECM11ConcReport_final_HR.pdf)

and electrically proximate generation nodes on the transmission network are grouped together into zones providing their nodal incremental costs are within +/-£1.00/kW. Other than in exceptional circumstances, zones are fixed for the duration of a Transmission Price Control Review period.

- 6.38 In the process of generation zoning, individual nodal costs (not more than +/-£1.00/kW apart) are averaged across the TNUoS charging zone in accordance with the demand weighting at each node to achieve a single zonal wider TNUoS tariff.
- 6.39 As the proposed connection designs for the Western Isles and eventually Orkney could lead to nodes on these islands being classed as MITS, thereby subsuming the island links to those islands into the wider element of the TNUoS tariff, there was some discussion in the Workgroup about how an island tariff would differ between a situation where it was classed as wider, and one where it was classed as local.
- 6.40 As the sub-sea transmission technologies proposed to connect these islands to the rest of the transmission network do not exist in the current TNUoS charging methodology, new expansion factors (i.e. annuitised unit costs) will have to be calculated for these. As a result of this limited pool of transmission assets the expansion factors for a circuit classed as local would be the same as that classed as wider.
- 6.41 On the main interconnected transmission system, where there are many nodes on the transmission network that are geographically and electrically proximate and connected by relatively low cost transmission technologies, the zoning criteria set out in paragraphs 6.37 and 6.38 will lead to a single average zonal TNUoS cost (comprised of individual nodal costs).
- 6.42 The Workgroup appreciated that, for island nodes classed as MITS in the future, the TNUoS charging methodology zoning criteria would result in the island (MITS) node itself being classed as a separate zone due to the relatively high cost of the sub-sea links used to connect them to the mainland. As a result of this zoning and the specific expansion factor the Workgroup noted that the island generation tariff for an island link classed as local or wider would be very similar. The only difference noted by the Workgroup would occur if the treatment under the sharing aspect of the modification varied between local and wider elements of the transmission network.

## **b) i) Review of Local/Wider definitions in the context of islands**

- 6.43 All non-embedded generation that is subject to TNUoS and not connected directly to a Main Interconnected Transmission System (MITS) substation will have a circuit component to their local TNUoS charge. For charging purposes a MITS substation is defined as:
- i) a Grid Supply Point (GSP) connection with 2 or more transmission circuits connecting at the substation; or
  - iii) more than 4 transmission circuits connecting at the substation.
- 6.44 The Workgroup considered that high unit cost transmission spurs connecting generation and demand that are comprised of network technology not included in the current expansion factors set out in the CUSC, such as those proposed between the Scottish mainland and the Scottish islands of the Western Isles, Orkney and Shetland were not considered at the time of defining the boundary between local circuits and the MITS.
- 6.45 According to the current island connection design proposals from TOs in Scotland, some island substations would be classified as MITS under the existing definition as soon as the island link has been constructed. The Workgroup has discussed this issue and concluded that, as the principles of the TNUoS charging methodology seek to calculate a locational signal that is cost reflective, the ultimate TNUoS tariff arising out of island links forming either part of a local circuit tariff or part of the wider tariff would be the same.
- 6.46 Given the unique nature of the proposed Scottish island transmission links in terms of cost and configuration, the Workgroup will need to consider which of the following approaches to incorporating islands into the TNUoS charging methodology is most efficient:
- i) Utilise the unique characteristics of island connections to exclude island substations forming part of the MITS, such that all island transmission links would form part of a local circuit tariff and only the issues associated with this would have to be addressed;
  - ii) Utilise the unique characteristics of island connections to include island substations as part of the MITS, such that all island transmission links would form part of the wider TNUoS tariff and only the issues associated with this would have to be addressed; and
  - iii) Maintain the existing definitions of local and wider and address the issues that arise for each category.
- 6.47 The Workgroup considered that there did not appear to be any justification to altering the definition of local and wider and maintaining an outcome where some island transmission links form part of a local circuit TNUoS tariff and others the wider TNUoS tariff.
- 6.48 To aid with the Workgroup's decision on how to proceed, a table outlining the high level issues associated with island links as 'Local' or 'Wider' was created, as set out in Table 8 below.

Issues to be addressed for island connections forming part of the 'Local' or 'Wider' network			
Charging Mechanism	(i) All Classed Local	(ii) All Classed Wider	(iii) Maintain Existing Definition
<i>Existing elements of the methodology</i>			
1 Expansion Factor	<b>ACTION REQUIRED:</b> A transmission technology specific expansion factor would have to be calculated as existing technology types (i.e. 132kV, 275kV and 400kV OHL and underground cable) insufficiently cost reflective.	<b>ACTION REQUIRED:</b> Same as 'All Classed Local'.	<b>ACTION REQUIRED:</b> Same as 'All Classed Local'.
2 Security Factor	<b>NO ACTION REQUIRED:</b> As local charges were created to deal with different levels of security, the existing TNUoS charging methodology implicitly deals with this issue.	<b>ACTION REQUIRED:</b> For the wider transmission network a Global Security Factor of 1.8 is applied.  As island transmission links will have less redundancy than the onshore network (due to the cost of the assets involved) a 'work around' would need to be established <u>for each island</u> whereby the expansion factor is adjusted to account for reduced security when links form part of the wider tariff, coupled with a review of access/compensation arrangements to ensure consistency.	<b>ACTION REQUIRED:</b> Same as 'All Classed Wider' <u>for those islands classed as wider.</u>
3 Zoning	<b>NO ACTION REQUIRED:</b> Island generation TNUoS tariffs comprised of both a local circuit tariff and the wider tariff associated with the zone in which the first MITS substation is located.	<b>NO IMMEDIATE ACTION REQUIRED:</b> Under the existing TNUoS zoning criteria of +/- £1kW, island substations would form their own wider TNUoS zone.  Zones usually updated once at the start of every TPCR period. However, re-zoning can occur for events with a significant impact on tariffs, such as the connection of an island.	<b>NO IMMEDIATE ACTION REQUIRED:</b> Same as 'All Classed Wider' <u>for those islands classed as wider.</u>
4 Demand Tariffs	<b>NO ACTION REQUIRED:</b> There are no local circuit tariffs for demand. Hence, for the purposes of calculating demand TNUoS tariffs, the islands would be treated in accordance with the existing TNUoS charging methodology.  As demand on the islands reduces the need for capacity on the island transmission link, the nodal incremental costs of demand on the islands would be negative. However, due to a statutory restriction (applying in northern Scotland) on	<b>NO ACTION REQUIRED:</b> Same as 'All Classed Local'.	<b>NO ACTION REQUIRED:</b> Same as 'All Classed Local'.

	demand zoning in this area, this benefit will be averaged across all nodes forming part of demand zone 1 (i.e. the north of Scotland).		
<i>New elements introduced in CMP213</i>			
5	Sharing	<p><i>Original Proposal</i>  <b>NO ACTION REQUIRED:</b>  To date there has been no evidence of sharing on local transmission circuits and the Original proposal assumes that sharing does not occur on this part of the network.</p> <p>Nevertheless, the Workgroup has discussed the possibility of applying sharing, where demonstrable, on local transmission circuits, as set out in b) (ii), below, and in great detail under 'Sharing applies to local' in Section 4.</p>	<p><i>Original Proposal</i>  <b>ACTION REQUIRED:</b>  For simplicity the Original does not differentiate between which elements of the wider transmission network are shared and which are not. This is currently deemed a reasonable simplification when compared to the associated impact on the cost reflectivity of TNUoS tariffs.</p> <p>If <u>all islands</u> were classed as wider, the balance between simplicity and cost reflectivity is altered and should therefore be re-assessed. Consideration of zonal diversity may be required in this instance.</p>
		<p><i>Original Proposal</i>  <b>ACTION REQUIRED:</b>  Same as 'All Classed Wider' for those <u>islands classed as wider</u>.</p>	

**Table 8 – Issues to be addressed for island connections as Local or Wider**

- 6.49 Some in the Workgroup believed that the unique cost and configuration characteristics of island connections were closer to that of local, rather than wider, circuits from the perspective of incremental transmission network costs.
- 6.50 Considering the issues needing to be addressed for each course of action set out in Table 8 above table to incorporate island transmission links into the TNUoS charging methodology and the fact that any approach that is cost reflective would ultimately result in the same TNUoS tariffs for island Users, the Proposer believed that the best course of action would be to explicitly define transmission connections with the same characteristics as island links as local for TNUoS charging purposes.
- 6.51 This approach would maintain the balance between simplicity and cost reflectivity inherent within the Original to continue across the wider transmission network (i.e. nodes classed as MITS). Any sharing that was deemed to take place on island transmission circuits, and all other local circuits, could be dealt with on a case-by-case basis as set out in (b) (ii), below.
- 6.52 Other members in the Workgroup noted that this would require a change to the definition of a MITS node and that this change would have to apply across the entire transmission network.
- b) ii) Apply sharing to local circuits incl. Scottish islands**
- 6.53 As set out above, the Original proposal applies the principles of sharing within it to all parts of the transmission network considered to be part of the Main Interconnected Transmission system (MITS; i.e. 'wider') for TNUoS charging purposes. Implicitly this would also include island connections

that are classed as ‘wider’. However, the Original does not extend sharing to local transmission circuits due to the fact that these circuits are not generally planned, in accordance with the NETS SQSS, taking sharing into account.

6.54 However, the Workgroup did consider that the principles of sharing could be extended to local transmission circuits where sharing of that capacity could be demonstrated. This discussion is recorded in the Section 4, “Summary of Workgroup Discussions on Sharing”, above.

**Q10: Do you believe that the Workgroup has considered all the options and potential alternatives for island nodes classed as part of the Main Interconnected Transmission System (MITS) and those classed as local? If not, what other options would you like the Workgroup to consider and why?**

**c) Whether the expansion factor should be calculated in a generic manner across all Islands or whether it should be island link specific**

6.55 The Original proposal would calculate a specific expansion factor for each island transmission circuit connection on the basis that the transmission technologies and hence unit costs could vary greatly across each connection. In addition, where HVDC transmission circuits are used the converter station costs are included in the expansion factor calculation, and hence circuit specific (i.e. with fixed length) would be necessary in order to maintain cost reflectivity.

6.56 The Workgroup considered that generic, rather than specific, expansion factors would generally rely on a sufficiently large population of cost data (i.e. installed transmission network components of a given technology) in order to reduce volatility and smooth out the obvious ‘winners’ and ‘losers’ that would arise from averaging just 2 or so numbers.

6.57 In addition, as one of the primary objectives of the TNUoS charging methodology is to be cost reflective in nature, the more averaging that takes place in coming up with a ‘generic’ number the less cost reflective the resultant TNUoS tariff will be. This trade off between cost reflectivity and stability occurs throughout the charging methodology.

6.58 The Workgroup put together a summary table of the pros and cons of having a generic vs. more specific expansion factor, from the perspective of some members, for island transmission connections. This is set out in Table 9, below.

Pros and Cons of Original proposal and Potential Options for Islands Expansion Factor		
Expansion Factor Potential Alternatives	Pros	Cons
Original proposal – Project specific (actual cost of the transmission project is used as basis for EF).	<ul style="list-style-type: none"> <li>Fully cost reflective.</li> <li>Stable once set.</li> <li>Could only benefit from potential drop in price of transmission asset when EF updated for</li> </ul>	<ul style="list-style-type: none"> <li>No opportunity to average costs across all Users as in the wider transmission network.</li> <li>All costs included in the locational signal</li> </ul>

	new projects	<ul style="list-style-type: none"> <li>• Cannot know TNUoS until very close to the time of build.</li> </ul>
i) Generic – e.g. based on and linked to onshore 132kV underground cable or other.	<ul style="list-style-type: none"> <li>• Tariffs predictable ahead of transmission project-specific costs.</li> </ul>	<ul style="list-style-type: none"> <li>• Does not reflect unit costs of transmission assets used.</li> <li>• Less cost reflective than specific (i.e. Original).</li> <li>• Could be based on generic HVDC costs.</li> </ul>
ii) Generic across relevant technologies e.g. one for island AC and one generic for DC.	<ul style="list-style-type: none"> <li>• More cost reflective than generic (i).</li> <li>• Tariffs more predictable than Original ahead of transmission project specific costs.</li> </ul>	<ul style="list-style-type: none"> <li>• Less cost reflective than specific (i.e. Original).</li> <li>• Equivalent to treatment in onshore wider and local. if also differentiates across voltage types</li> </ul>
iii) Island or Island Group specific – but not transmission project specific; i.e. actual cost of cables to the Islands aggregated or averaged over all projects and islands in the 'group'. or certain cost elements specifically removed.	<ul style="list-style-type: none"> <li>• More cost reflective than generic (i) and (ii)</li> <li>• Allows island-specific factors to be incorporated for potential alternatives</li> <li>• For second and subsequent transmission cables – more chance of predicting TNUoS.</li> </ul>	<ul style="list-style-type: none"> <li>• Less cost reflective than specific (i.e. Original).</li> <li>• Limited opportunity to average-out a very high single transmission asset cost.</li> <li>• Generators on first cable cannot know TNUoS until very close to the time of transmission build.</li> <li>• Some Islands or projects could subsidise others.</li> </ul>

**Table 9 – Pros and Cons of a generic and specific expansion factor**

**c) i) Across all islands regardless of technology**

6.59 The Workgroup discussed the possibility of calculating a single generic expansion factor for all island transmission connections.

6.60 It was recognised by the Workgroup that the planned transmission connections to Scottish islands are to be comprised of AC and HVDC technology of different voltages and capacities. As such, the unit cost of each transmission circuit is likely to vary considerably across each connection.

6.61 The majority of the Workgroup believed that any advantages in simplicity and predictability of TNUoS tariffs by use of a generic factor was outweighed by the significant lack of cost reflectivity associated with such an approach.

6.62 Other members in the Workgroup felt that a generic factor would be appropriate on the basis that the reduction in cost reflectivity is outweighed by the benefits of predictability for generation projects still under development.

**c) ii) One generic expansion factor for AC, and one for DC**

6.63 The Workgroup considered that using one generic factor for AC transmission connections to the islands and a separate one for DC island links would be more cost reflective and has the potential to be slightly less stable than a single generic factor for all island transmission connections.



6.64 Given the significant unit cost differences of the proposed island transmission connections the Workgroup felt that a single generic factor may be difficult to justify in comparison to the rest of the TNUoS charging methodology. However, breaking this out into an AC and DC factor might be easier to justify against the primary (cost reflectivity, effective competition) and secondary (predictability, transparency, stability, etc.) objectives of the TNUoS charging methodology.

**c) iii) Island (i.e. not connection) or Island Group specific**

6.65 The Workgroup discussed a third potential option, which would calculate expansion factors on an island or island group (i.e. the three Scottish island groups of (i) the Western Isles (ii) Orkney and (iii) Shetland), rather than on a transmission circuit specific basis.

6.66 This particular approach would only alter TNUoS tariffs compared to the Original proposal where more than one transmission connection was established between a particular island, or group of islands, and the rest of the transmission network.

6.67 An additional benefit highlighted for this approach was that of enhanced predictability and stability of TNUoS tariffs.

6.68 One member of the Workgroup considered that one of the benefits of such an approach would be that it would allow other aspects of costs, such as savings in diesel fuel running costs, to be incorporated into the expansion factor calculation.

6.69 The Workgroup debated whether such costs were relevant in the context of a TNUoS charging methodology which sought to signal incremental costs of investment in transmission network capacity. The Workgroup concluded that diesel running costs were not relevant to the calculation of the (transmission network) expansion factor and that these costs were already subsidised through (i) demand TNUoS charges and (ii) the “Assistance for Areas with High Distribution Costs” scheme where SHEPD is subsidised with respect to these diesel running costs.

6.70 The Workgroup recognised that further detailed development would be required for such an approach (e.g. how would islands be grouped) if it were to be considered as a potential option.

**d) Whether, for islands classed as ‘wider’, the global locational security factor should be used without further modification or whether any lack of redundancy should be reflected in the expansion factor calculation**

6.71 As set out in Section 5, “Summary of Workgroup Discussions on HVDC”, above, the prevailing security factor for the wider transmission network is 1.8 and is based on an average from a number of studies conducted by NGET to account for future transmission network developments. The security factor is reviewed for each Transmission Price Control Review period and fixed for the duration.

- 6.72 The 1.8 security factor is calculated on a nodal basis and averaged using a least squares fit method to derive a transmission system wide figure, which ultimately is multiplied times the zonal locational tariff before application of the residual element in order to arrive at the TNUoS tariffs paid by generators. Currently this factor is applied to all MITS (i.e. wider) nodes on the transmission network.
- 6.73 The Workgroup discussed the fact that a straight extrapolation of the current charging methodology would lead to island nodes that are classed as wider also having TNUoS tariffs multiplied by 1.8. This was also a topic of some debate in the Project TransmiT SCR Technical Working Group, at which time it was concluded that charging island Users that had a transmission circuit with a significant proportion of no redundancy a TNUoS tariff multiplied fully by the 1.8 security factor (as applied, to mainland connections, where such redundancy did exist) would not be cost reflective.
- 6.74 Therefore, the Original proposal would adjust the length of any portion of an Island link with no redundancy in the Transport model to compensate by multiplying its actual length by  $1/(\text{Locational Security Factor})$ . The result would be that when the TNUoS tariff was later multiplied by the locational (MITS) security factor (currently 1.8) this would cancel out and only be reflected as a single transmission circuit in the TNUoS tariff; i.e. it would result in an island security factor of 1.0, rather than 1.8.
- 6.75 Discussion in the Project TransmiT SCR Technical Working Group also considered that the transmission access rights of Users on islands who were not charged the full (MITS) locational security factor (of 1.8) should be commensurate with this lower (1.0) level of redundancy, such that generation Users would not be eligible for CUSC compensation for loss of the single transmission circuit element.
- 6.76 The Workgroup investigated alternatives to this approach, as set out below.

**d) i) Apply 1.8 in all cases**

- 6.77 Based on the lengthy debates in the Project TransmiT SCR Technical Working Group on this option and further discussion within the CMP213 Workgroup, the Workgroup agreed that an application of the 1.8 security factor to radial transmission circuits with large sections of no redundancy would not be cost reflective and that a more appropriate security factor should apply.
- 6.78 Hence, if islands were to be classed as 'wider' for TNUoS charging purposes, the Workgroup agreed that the application of 1.8 in all cases would not be appropriate and no potential alternatives were being considered in this area.

**d) ii) Apply a factor between 1.0 and 1.8 in all cases**

6.79 The approach to local circuits onshore is that the security factor applied is either 1.0 or 1.8, depending on the number of circuits making up the connection (i.e. 1 circuit = 1.0 and 2 circuits = 1.8). With the introduction of the offshore regulatory regime and associated offshore charging arrangements, the concept of partial redundancy was introduced. These allowed security factors of between 1.0 and 1.8 to be applied based on both the number and capacity of circuits.

6.80 Whilst the Workgroup discussed the concept of partial redundancy, as applied to offshore TNUoS charging, and a number supported its application to islands on the basis that it was accurate and cost reflective. Others felt that the proposed island transmission connections would not be part of the offshore regime and that it may therefore be difficult to justify different treatment to onshore.

6.81 Nevertheless there was support for this approach in the Workgroup.

**Q11: Do you believe that the Workgroup has considered all relevant options and potential alternatives for how the global locational security factor could be applied to island connections with little or no redundancy? If not, what other options would you like the Workgroup to consider and why?**

**e) Whether the expansion factor calculation for radial island links comprising HVDC technology should be the same as that for HVDC links that parallel the AC network**

6.82 The Original proposal would calculate the expansion factor for HVDC island transmission links in the same manner as for those that parallel the AC transmission network.

6.83 As part of the Original proposal all converter station costs are included in the calculation of the HVDC transmission circuit expansion factor.

6.84 The Workgroup investigated a potential alternative to this approach, as set out below.

**e) i) Yes, for all aspects of the methodology**

6.85 The Workgroup considered whether this would be the case for all the aspects of the HVDC TNUoS charging as discussed in Section 5, above.

6.86 The Workgroup agreed that, due to the radial nature of the proposed island HVDC transmission links, the calculation of impedance for these links as is necessary when they parallel the AC transmission network was not required.

6.87 In terms of the calculation of the expansion factor for HVDC transmission links the Workgroup considered complete removal and partial removal of the converter station costs from the expansion factor calculation as well as treating HVDC as onshore in Section 5.

- 6.88 The justification for complete removal of the converter station costs was on the basis that these elements constitute a fixed cost and hence somehow have a negative effect on cost reflectivity. Whilst this was disputed by some of the Workgroup, this justification would also apply to island HVDC links and therefore for this potential alternative the calculation should remain the same.
- 6.89 The interaction and potential read across to offshore transmission circuits where HVDC converter costs are included in the expansion factor calculation was noted by the Workgroup. Some believed that this inconsistency was not acceptable and that converter station costs would also have to be removed from the offshore TNUoS calculation in this case.
- 6.90 Some in the Workgroup also noted that, unlike offshore transmission circuits, the island links did include demand Users and, furthermore, islands are not considered to be offshore as they are part of the (onshore) TO's Transmission Licence area (and are not part of an OFTO's Transmission Licence area). These members believed that these reasons alone were sufficient to warrant a different treatment of HVDC converter station costs when calculating TNUoS between islands and offshore.
- 6.91 As set out above, in Section 5, the Workgroup also identified 3 possible alternatives for the removal of a portion of the converter station costs from the expansion factor calculation:
- iii) Remove a percentage of, the costs based on those elements of the converter station that are similar to elements of the (onshore) AC transmission network that are currently not included in the locational signal (such as substation equipment); and/or
  - iv) Remove a portion of the costs based on the similarity between the power flow redirecting capability of HVDC converter stations and that of Quadrature Boosters (QBs) that are currently not included in the locational signal
  - v) Remove a portion of costs based on the benefit to the transmission network arising from the operation of HVDC technology. This is particularly relevant to voltage source converters (VSC), which will be used for island links, which can be beneficial to system performance and can provide overall a more effective solution than traditional HVAC.
- 6.92 For the first option devised for incorporating HVDC circuits that parallel the AC network, the Workgroup noted that this justification would also apply for radial island HVDC transmission circuits. However, as with the potential alternative removing all converter station costs from the expansion factor calculation, some in the Workgroup believed that the logic for applying this option could also be read across to the existing TNUoS charging methodology with respect to offshore (OFTO) transmission.
- 6.93 Nevertheless, some of the Workgroup believe that offshore should not be used as a precedent to determine the charging structure for island links. Whilst there are some similarities there are also important commercial and technical differences between the two types of connection:

- Specific commercial arrangements have been put in place to help facilitate the development of offshore wind technology, including levels of policy support and the OFTO arrangements in respect of connections. Offshore connections tend to be radial links to individual generator stations.
- Island links will be part of the onshore TO's Transmission Licence area and are not part of an OFTO's Transmission Licence. The island links will connect multiple generator stations covering different technologies. The island links will also serve to benefit the islands themselves improving the quality and security of supplies in these remote areas, providing capacity to facilitate demand side growth, and relieving reliance on local carbon standby generation. The links to certain islands will also relieve congestion on other sections of the transmission network.

6.94 The second option devised for incorporating HVDC circuits that parallel the AC network for removal of a portion of the converter station costs is associated with the power flow re-directing capability of HVDC transmission links and their similarity to Quadrature Boosters (QBs) in this respect. As such, some in the Workgroup believed that the radial nature of the island HVDC transmission links precluded this option from applying to the expansion factor calculation for island links comprised of HVDC transmission technology.

6.95 The third option is to recognise the benefits arising from the VSC converter technology, which is based on transistor valves which are much more controllable than conventional thyristor based current source converters (CSC). In the correct circumstances, installation of HVDC VSCs links can be beneficial to overall transmission system performance.

6.96 VSC technology can rapidly control both active and reactive power independently of one another. Reactive power can also be controlled at each terminal independent of the DC transmission voltage. VSC can also permit black start where the converter station can be used to bring parts of the transmission network back online following outages. The dynamic support of the AC voltage at each converter terminal improves the voltage stability and can increase the transfer capability of the connected AC transmission systems.

6.97 In the case of island transmission links, HVDC based on VSC technology can provide a better solution than traditional HVAC, taking into account technical capability, cost and environmental impact.

6.98 Further work is being undertaken by some Workgroup members to reflect how this could be translated into TNUoS, either through a new potential alternative, or through current alternatives to remove all, or a portion of, the converter station costs from the expansion factor calculation

6.99 Hence the Workgroup agreed that the aspects of the modification proposal for incorporating HVDC circuits that parallel the AC network should also apply to island transmission connections comprised of HVDC technology and that some of the options discussed for calculation of the expansion factor could also apply to island connections (although these could be

limited due to their radial nature). Some Workgroup members believed all options could apply including removal of all, or all options for removal of a portion of, the converter costs.

**Q12: Do you believe that the Workgroup has sufficiently considered the options and potential alternatives for how the expansion factor (i.e. unit cost) for sub-sea cables and/or radial HVDC circuits forming part of an island connection should be calculated for inclusion in the TNUoS charging calculation? If not, please provide suggestions with an associated justification.**

**f) Whether an anticipatory application of the MITS definition to islands is appropriate and how this could be done.**

6.100 Currently a node on the transmission network is classed as MITS for the charging year in question based solely on the network configuration in place at the time TNUoS charges are set.

6.101 As set out in paragraph 6.42, all Workgroup members appreciated the fact that a cost reflective island TNUoS tariff should be similar whether the island transmission node is classed as local or wider for charging purposes, but also noted the interaction with the sharing aspect of the Original proposal where the application of a sharing factor may differ between local and wider.

6.102 The Original proposal would utilise the existing local/wider definition and only apply one treatment or another when the relevant criteria are met and not in advance as would be the case if applied in an anticipatory fashion.

6.103 If an anticipatory approach were to be used the Workgroup understood this to mean, for the purposes of their deliberations, that the existing definition of a MITS substation would be applied (in advance of it actually occurring) to an island transmission link (for the purposes of TNUoS charging) where it was reasonably 'anticipated', by the SO, that such a MITS substation would exist at some point in the future. The timeframe as to how far in advance the SO should consider when looking to 'anticipate' the establishment of the MITS substation onto a particular island was debated by the Workgroup.

6.104 There were was a cross section of views on whether an anticipatory application of the MITS definition was appropriate and, if so, how this could be achieved.

6.105 The Workgroup agreed that the relevance of an anticipatory application of the MITS substation definition to the islands is material because the sharing factor under the Original proposal is applied to island nodes classed as MITS.

6.106 The Workgroup had concerns in this area, which are set out in Section 4 above.

6.107 This was considered in the potential alternatives, set out below.

6.108 The Workgroup noted that the potential alternatives in this area interacted heavily with those discussed under sharing where application of sharing to local transmission circuits, including on an anticipatory basis, was considered.

**f) i) Yes, just for islands**

6.109 As set out in paragraph 6.42, all Workgroup members appreciated the fact that a cost reflective island TNUoS tariff should be similar whether the island transmission node was classed as local or wider for charging purposes, but also noted the interaction with the sharing aspect of the Original proposal where the application of a sharing factor may differ between local and wider.

6.110 Some members of the Workgroup, therefore did not see any justification for an anticipatory application of the MITS substation definition to anywhere on the transmission network; be that onshore, on the islands or offshore. Nevertheless, others in the Workgroup believed that an anticipatory application of the MITS substation definition may be justified in some cases.

6.111 Nevertheless, some in the Workgroup considered that, should such an anticipatory application only apply to island transmission connections that this would be discriminatory in nature and would need to be applied across the transmission network as a result.

**f) ii) Yes, for all areas**

6.112 Whilst some in the Workgroup did not see any justification for an anticipatory application of the MITS substation definition to any part on the transmission network, others did believe that it may be justified.

6.113 As a result, these members of the Workgroup are developing an option for island charging that would include this approach.

**Q13: Do you consider that the Workgroup has adequately considered all relevant options and alternatives for an anticipatory application of the MITS definition to island nodes? If not, please provide suggestions with an associated justification.**

**Q14: Do you consider that the Workgroup has adequately set out and considered all relevant options and potential alternatives on the “island connection” aspect of this modification proposal? If not, what other options would you like the Workgroup to consider and why?**

**Q15: What are your overall views on how best to include island connections comprising sub-sea cable and/or HVDC technology, such as those proposed in Scotland, into the TNUoS charging methodology?**

## Annex 7 – Project TransmiT Background

### *Project TransmiT*

- 7.1 Project TransmiT was Ofgem's independent and open review of transmission charging and associated connection arrangements. The stated aim of Project TransmiT was to ensure that arrangements are in place to facilitate the timely move to a low carbon energy sector whilst continuing to provide safe, secure, high quality network services at value for money to existing and future consumers.
- 7.2 Ofgem launched a Call for Evidence<sup>17</sup> on 22 September 2010, inviting views on the scope of and priorities for the Project TransmiT review and called for evidence from generators, shippers, suppliers, network companies, consumers and their representatives, the sustainable development community and other interested parties. Ofgem anticipated, at that time, coming to a conclusion in the summer of 2011.
- 7.3 The review initially incorporated charging and connections arrangements for electricity and gas as well as consideration for Carbon Capture and Storage.
- 7.4 In their scoping document<sup>18</sup> of 25 January 2011 Ofgem clarified the scope of Project TransmiT. After considering responses to the Call for Evidence and views expressed at a stakeholder event, electricity connection issues and electricity transmission charging arose as the immediate priority.
- 7.5 In parallel, Ofgem commissioned a series of reports from consultants and academics to gather evidence focused on the electricity transmission charging regime, with consideration for interactions with the gas regime and consistency of key principles. These reports were published on the Ofgem Project TransmiT web forum<sup>19</sup> in May 2011.
- 7.6 Also in May 2011, Ofgem published an open letter<sup>20</sup> setting out their approach to work on electricity charging under Project TransmiT. In this letter Ofgem set out that the charging work would focus specifically on charging arrangements that seek to recover the costs of providing electricity transmission assets; i.e. Transmission Network Use of System (TNUoS) Charging.
- 7.7 In addition the aforementioned May 2011 open letter set out the view that this work should be progressed through a Significant Code Review (SCR) and that the approach was consistent with the original scope of Project TransmiT, which was seeking to address issues that are an immediate priority, and should enable any appropriate changes to be introduced in the short term. Ofgem noted they hoped to come to a conclusion in late summer 2011 and that, if appropriate, the aim would be to implement any change to TNUoS in time for the following charging year; i.e. April 2012. However, they recognised that this was an ambitious and challenging timetable and therefore did not rule out the possibility of implementing appropriate changes at a later date. Ofgem subsequently confirmed that changes, where appropriate, would be implemented after April 2012 to allow for further analysis<sup>21</sup>.

<sup>17</sup> <http://www.ofgem.gov.uk/Pages/MoreInformation.aspx?docid=1&refer=Networks/Trans/PT>

<sup>18</sup> [http://www.ofgem.gov.uk/Networks/Trans/PT/Documents1/110125\\_TransmiT\\_Scope\\_Letter\\_Final.pdf](http://www.ofgem.gov.uk/Networks/Trans/PT/Documents1/110125_TransmiT_Scope_Letter_Final.pdf)

<sup>19</sup> <http://www.ofgem.gov.uk/Networks/Trans/PT/WF/Pages/WebForum.aspx>

<sup>20</sup> [http://www.ofgem.gov.uk/Networks/Trans/PT/Documents1/110527\\_TransmiT\\_charging\\_letter.pdf](http://www.ofgem.gov.uk/Networks/Trans/PT/Documents1/110527_TransmiT_charging_letter.pdf)

<sup>21</sup> [http://www.ofgem.gov.uk/Networks/Trans/PT/Documents1/110909\\_TransmiT\\_charging\\_SCR\\_update.pdf](http://www.ofgem.gov.uk/Networks/Trans/PT/Documents1/110909_TransmiT_charging_SCR_update.pdf)



## Significant Code Review (SCR) Technical Working Group (the “Working Group”)

- 7.8 Following a consultation in July 2011, Ofgem announced their intention to launch an SCR<sup>22</sup> on electricity transmission charging issues under Project TransmiT and to conclude by December 2011. The launch statement set out the timetable and next steps for the SCR, making clear that collaborative and constructive input from industry would be essential to timely delivery of any appropriate changes. In its open letter of September 2011 Ofgem indicated that the timetable would be extended to March 2012.
- 7.9 The scope of the SCR was to develop and assess a range of charging options that focus on TNUoS charging alone and therefore excluded options that imply wider changes (i.e. those that would, to varying degrees, impact the current GB electricity trading arrangements). This range is illustrated in Figure A4.1, below.



**Figure A7.1 - Range of Charging Options**

- 7.10 The scope of the Project TransmiT SCR also excluded any changes to the charges that recover the cost of system operation (i.e. Balancing Services Use of System (BSUoS) charges) and charges that recover the cost of connection (connection charges) were also excluded from the scope of the Project TransmiT SCR.
- 7.11 Currently TNUoS charges are calculated by National Grid as National Electricity Transmission System Operator (NETSO) in accordance with the GB Use of System Charging Methodology<sup>23</sup>. Changes to the methodology are subject to the Connection and Use of System Code (CUSC) governance process<sup>24</sup>.
- 7.12 In accordance with National Grid’s Transmission Licence Condition C5, TNUoS charges are currently calculated (and changes assessed) in accordance with the relevant objectives, which state that these charges should (paraphrased for convenience):
- Facilitate effective competition in the generation and supply of electricity;
  - Reflect, as far as reasonably practicable, the costs incurred by transmission licensees in their transmission businesses;
  - Properly take account of the developments in transmission licensees’ transmission businesses.
- 7.13 In addition to the relevant charging objectives above, the Transmission Licence (Standard Licence Condition C7) also prohibits National Grid from discriminating against any User or class of Users unless such different

<sup>22</sup> [http://www.ofgem.gov.uk/Networks/Trans/PT/Documents/1/110707\\_Final%20launch%20SCR%20statement.pdf](http://www.ofgem.gov.uk/Networks/Trans/PT/Documents/1/110707_Final%20launch%20SCR%20statement.pdf)

<sup>23</sup> Section 14 of the Connection and Use of System Code, [http://www.nationalgrid.com/NR/rdonlyres/8FFA9408-9DC7-44C2-AF68-93E684A176D8/47549/CUSC\\_Section\\_14combinedmasterclean5July11\\_FINAL.pdf](http://www.nationalgrid.com/NR/rdonlyres/8FFA9408-9DC7-44C2-AF68-93E684A176D8/47549/CUSC_Section_14combinedmasterclean5July11_FINAL.pdf)

<sup>24</sup> Section 8 of the Connection and Use of System Code, [http://www.nationalgrid.com/NR/rdonlyres/8B81E9A0-F1B1-47B7-906D-41DA0DB69167/45131/CUSC\\_Section\\_8\\_v19\\_CAP179\\_WGAA2\\_31Jan11.pdf](http://www.nationalgrid.com/NR/rdonlyres/8B81E9A0-F1B1-47B7-906D-41DA0DB69167/45131/CUSC_Section_8_v19_CAP179_WGAA2_31Jan11.pdf)

treatment reasonably reflects differences in the costs of providing a service.

- 7.14 The basis for the current charging methodology is the Investment Cost Related Pricing (ICRP) approach, which calculates TNUoS tariffs that vary according to the incremental cost of supplying transmission network capacity at different locations across GB. The principle behind this approach is one of providing economic signals that allow transmission users to factor their impact on the transmission network into siting locational decisions and hence provide an overall economic generation and transmission system for end consumers.
- 7.15 As part of the SCR launch, Ofgem set out to establish a Technical Working Group in order to develop the technical detail of two alternative approaches to TNUoS charging. These approaches, a 'Postage Stamp' model and an 'Improved ICRP' model, were to be assessed alongside the existing 'Status Quo' ICRP model in an impact assessment by Ofgem's appointed economic consultants, Redpoint Consulting Limited. Ofgem also indicated that connection charging arrangements, embedded generation and the small generator discount (Standard Licence Condition C13) were out of scope of the SCR.
- 7.16 The Technical Working Group, comprised of fifteen representatives covering a broad range of stakeholder interests, met on a fortnightly basis between July and September 2011 in order to discuss and develop the aforementioned models to be taken forward for economic analysis. The deliberations of the Technical Working Group focused around six broad themes, categorised by Ofgem as follows:

Theme
1. Reflecting characteristics of transmission users
2. Geographical/topological differentiation of costs
3. Treatment of security provision
4. Reflecting new transmission technology
5. Unit cost of transmission capacity
6. G:D split

**Table A7.1 – Themes of the deliberations of the Technical Working Group**

- 7.17 The recommendations of the Technical Working Group for each of the six themes under the three charging models that were under consideration are set out below.
- 7.18 For an extension of the Status Quo model out to the end of the modelling time horizon, 2030, the following recommendations were made by the Technical Working Group:

Status Quo (ICRP extended to 2030)	
Theme	Outcome
1	<ul style="list-style-type: none"> <li>no change</li> </ul>
2	<ul style="list-style-type: none"> <li>no change</li> </ul>
3	<ul style="list-style-type: none"> <li>no change</li> <li>noted that some island connections could be classed as wider for charging purposes and would therefore have a security factor of 1.8</li> </ul>
4	<ul style="list-style-type: none"> <li>model HVDC links that parallel the onshore network as an equivalent AC circuit by:               <ol style="list-style-type: none"> <li>determining impedance from an HVDC power flow calculated as the</li> </ol> </li> </ul>

	<p>average of a ratio of total network boundary rating versus HVDC link rating for all boundaries that the link crosses</p> <p>ii) No consensus on calculating expansion factor for the HVDC link; choice of either:</p> <p>a) excluding converter costs or</p> <p>b) including all costs</p>
5	<ul style="list-style-type: none"> <li>no change</li> </ul>
6	<ul style="list-style-type: none"> <li>move from a G/D revenue collection split of 27/73 to 15/85 from 2015</li> </ul>

**Table A7.2 –Technical Working Group recommendations for Status Quo model**

7.19 The economic modelling of the Status Quo was undertaken, by Redpoint Consulting Limited, on a charging approach consistent with the Technical Working Group’s recommendations, set out above. Where there was no consensus, on the costs that should be incorporated into the HVDC expansion factor calculation, Ofgem decided to undertake the modelling including all costs.

7.20 The Technical Working Group’s recommendations for the Improved ICRP model were as follows:

Improved ICRP	
Theme	Outcome
1	<ul style="list-style-type: none"> <li>Dual background approach to the Transport Model used in calculating locational differentials (Peak Security and Year Round backgrounds)</li> <li>Background scaling factors for plant types consistent with NETS SQSS proposals under GSR009</li> <li>The use of a two part tariff commensurate with the dual backgrounds</li> <li>No consensus on plant contributing to tariff elements; choice of: <ul style="list-style-type: none"> <li>i) Intermittent plant only contributes to Year Round element; or</li> <li>ii) All plant contribute to both Peak Security and Year Round element</li> </ul> </li> <li>No consensus on tariff calculation for Year Round element; choice of: <ul style="list-style-type: none"> <li>i) TEC only</li> <li>ii) TEC x specific historic load factor</li> <li>iii) TEC x generic load factor for plant type</li> <li>iv) TEC x specific forecast load factor (with reconciliation)</li> <li>v) TEC x ex-post MWh</li> </ul> </li> </ul>
2	<ul style="list-style-type: none"> <li>no change to zoning criteria or local/wider boundary</li> </ul>
3	<ul style="list-style-type: none"> <li>no change</li> <li>for island connections that would be classed as wider for charging purposes and that have significant sections of single circuit (i.e. islands with single circuit sub-sea connections) the expansion factor for this section would be calculated by dividing the unit cost by 1.8</li> </ul>
4	<ul style="list-style-type: none"> <li>focus on HVDC links only</li> <li>model HVDC links that parallel the onshore network as an equivalent AC circuit by: <ul style="list-style-type: none"> <li>i) Determining impedance from an HVDC power flow calculated as the average of a ratio of total network boundary rating versus HVDC link rating for all boundaries that the link crosses</li> <li>ii) No consensus on calculating expansion factor for the HVDC link; choice of either: <ul style="list-style-type: none"> <li>a) excluding converter costs or</li> <li>b) including all costs</li> </ul> </li> </ul> </li> </ul>
5	<ul style="list-style-type: none"> <li>no change</li> </ul>

6	<ul style="list-style-type: none"> <li>• move from a G/D revenue collection split of 27/73 to 15/85 from 2015</li> </ul>
---	--------------------------------------------------------------------------------------------------------------------------

**Table A7.3 – Technical Working Groups recommendations for ICRP model.**

- 7.21 In addition to the areas where the Technical Working Group did achieve consensus, there were a few areas under Themes 1 and 4 where Ofgem had to make a decision on how they would be modelled by Redpoint Consulting Limited. These were as follows:
- 7.22 Theme 1 – Intermittent plant would contribute to the Year Round element of the tariff only and the tariff calculation would include a generation plant specific historic load factor.
- 7.23 Theme 4 – When calculating the expansion factor for HVDC links all asset costs would be included.
- 7.24 The Technical Working Group’s recommendations for the Postage Stamp (a.k.a. ‘Socialised’) model were as follows:

Postage Stamp	
Theme	Outcome
1	<ul style="list-style-type: none"> <li>• no consensus on reflecting user characteristics; choice of allocating charges based on:               <ol style="list-style-type: none"> <li>MW or</li> <li>MWh</li> </ol> </li> </ul>
2	<ul style="list-style-type: none"> <li>• no consensus on differentiation of costs; choice of:               <ol style="list-style-type: none"> <li>maintain existing local/wider boundary</li> <li>remove local/wider boundary and socialise all costs</li> <li>continue to calculate an ICRP based demand charge</li> <li>charge demand on the same basis as generation (i.e. socialised)</li> </ol> </li> </ul>
3	<ul style="list-style-type: none"> <li>• not relevant for wider tariffs</li> <li>• no change for local if maintaining local/wider boundary</li> </ul>
4	<ul style="list-style-type: none"> <li>• not relevant for a postage stamp model</li> </ul>
5	<ul style="list-style-type: none"> <li>• no change for local if maintaining local/wider boundary</li> </ul>
6	<ul style="list-style-type: none"> <li>• move from a G/D revenue collection split of 27/73 to 15/85 from 2015</li> </ul>

**Table A7.4 – Technical Working Groups recommendations for the Postage Stamp model.**

- 7.25 Under the Postage Stamp model there was a lack of consensus under Theme 1 and Theme 2. Here Ofgem decided that the following would be taken forward for economic modelling:
- 7.26 Theme 1 – Postage Stamp charges were to be calculated on a MWh basis
- 7.27 Theme 2 – Remove the local/wider boundary and socialise all costs; charge demand on the same basis as generation (i.e. socialised)
- 7.28 In addition to model development, the Technical Working Group was also given the opportunity to comment on the input assumptions to the economic modelling exercise being undertaken in parallel by Redpoint Consulting Limited.
- 7.29 A record of the SCR Technical Working Group’s deliberations and recommendations to Ofgem on the form of the alternative approaches under consideration (i.e. Postage Stamp and Improved ICRP) is available in the form of the Technical Working Group’s initial report<sup>25</sup> published on

<sup>25</sup> <http://www.ofgem.gov.uk/Networks/Trans/PT/WF/Documents1/TransmiT%20WG%20Initial%20Report.pdf>

the 6<sup>th</sup> of October 2011. In addition, the comments and feedback from the Technical Working Group on the various inputs and outputs of the economic modelling exercise is logged in an November 2011 addendum to the initial report<sup>26</sup>.

### ***Economic Analysis and SCR Conclusions***

- 7.30 Redpoint Consulting Limited as commissioned by Ofgem to provide a quantitative assessment of how the different charging options might impact on the objectives of Project TransmiT, as set out above.
- 7.31 The analytical approach taken by Redpoint in this modelling assessed the impact of the transmission charging options on investment in generation and transmission. Transmission charges will influence the decisions of generators regarding where to locate their plant, and which plant to retire. This in turn has an impact on transmission charges; as well affecting the level of constraint costs which will drive future decisions on when and where to reinforce the transmission network. These reinforcements then feed into transmission charges which then also influence generators' decisions.
- 7.32 To undertake the analysis a modelling framework was developed by Redpoint that incorporated modules for transmission charging, system despatch, market pricing, constraint forecasting, and generation and transmission investment decision making within GB. This was done with input from National Grid Electricity Transmission and Ofgem, as well as with feedback from the aforementioned Technical Working Group. A full report of the modelling approach, assumptions and results is available on Ofgem's website<sup>27</sup>.
- 7.33 Utilising the outcome of the Redpoint economic analysis, Ofgem published their assessment<sup>28</sup> of the options for change to TNUoS charges on the 20<sup>th</sup> of December 2011. This assessment covered the three main options set out above in addition to two policy variants (an Improved ICRP model that excludes converter station costs from HVDC and a Postage Stamp variant that retains the local tariff for generators).
- 7.34 The assessment was carried out against the three broad aims of Project TransmiT:
- i) deployment of low carbon generation across Great Britain (GB) and impact on achieving the UK Government's Renewable Energy Strategy target of 30% of generation from renewable sources by 2020 and reduced carbon intensity by 2030.;
  - ii) quality and security of supply across GB; and
  - iii) overall cost of the transmission system as a whole and customer bill impacts.
- 7.35 Ofgem noted that the charging options modelled by Redpoint resulted in very different patterns of TNUoS charges across generators, but that each was consistent with meeting the UK Government's 2020 renewable target and carbon intensity goals with no material differences in the implications for security of supply. They noted that the key differences between the options were the impacts on power sector costs and consumer bills.

---

<sup>26</sup> [http://www.ofgem.gov.uk/Networks/Trans/PT/WF/Documents1/TransmiT%20WG%20Addendum%20to%20Initial%20Report\\_final.pdf](http://www.ofgem.gov.uk/Networks/Trans/PT/WF/Documents1/TransmiT%20WG%20Addendum%20to%20Initial%20Report_final.pdf)

<sup>27</sup> <http://www.ofgem.gov.uk/Networks/Trans/PT/Documents1/Modelling%20the%20impact%20of%20transmission%20charging%20options.pdf>

<sup>28</sup> <http://www.ofgem.gov.uk/Networks/Trans/PT/Documents1/Project%20TransmiT%20Dec11.pdf>

- 7.36 Based on the evidence and their assessment of it, Ofgem consulted on ruling out socialised TNUoS charging (a Postage Stamp approach) as an option primarily due to the disproportionate costs and associated impacts on consumer bills associated with such an approach.
- 7.37 Subsequently, in their Significant Code Review conclusions document<sup>29</sup> published on the 4<sup>th</sup> of May 2012, Ofgem confirmed that a socialised approach to TNUoS charging should not be progressed and reaffirmed the principle of cost reflectivity in transmission charging. Whilst it was considered that the choice between Improved ICRP and maintaining the Status Quo was not clear cut, Ofgem remained of the view that an improved form of ICRP was the best way forward.
- 7.38 In their conclusions Ofgem noted that only one form of Improved ICRP was modelled by Redpoint and that they expected the approach could be improved further and that industry was best placed to further progress the work and consider alternatives that best deliver the objectives of Project TransmiT.
- 7.39 As such, Ofgem set out to direct National Grid Electricity Transmission to raise an amendment proposal to the Connection and Use of System Code (CUSC) to ensure that the TNUoS methodology:
- i) Better reflects the costs imposed by different types of generators on the electricity transmission network (a.k.a. network **sharing**);
  - ii) Takes account of the development of **HVDC links** that will run parallel to the onshore transmission network; and
  - iii) Takes into account the potential **island links**, such as those that are currently being considered for Scottish islands.
- 7.40 On the 25<sup>th</sup> of May 2012, Ofgem directed NGET<sup>30</sup> to raise a modification proposal to the CUSC.

### **SCR Direction**

- 7.41 The terms of the SCR Direction set out the specific issues that NGET's Proposal to modify the Use of System Charging Methodology should consider and address under each of the three aforementioned areas.

### Sharing

- 7.42 For reflecting the costs imposed by different types of generations the Direction obliged NGET to include proposals suggestions for modifying TNUoS:
- i) so that generator charges are calculated using a dual background approach, by reference to the impact of different types of generation located at different points on the network on the incremental costs of transmission infrastructure required to secure demand at the system peak (the peak security condition), and the incremental costs of transmission infrastructure investment associated with efficient year round operation of the transmission system (the year round condition) in a manner consistent with the SQSS;
  - ii) so that the peak condition is calculated by reference to the generation background scaling factors used in the derivation of the Security Planned Transfer condition under Appendix C of the NETS SQSS;

---

<sup>29</sup> <http://www.ofgem.gov.uk/Networks/Trans/PT/Documents1/TransmiT%20SCR%20conclusion%20document.pdf>

<sup>30</sup> <http://www.ofgem.gov.uk/Networks/Trans/PT/Documents1/Final%20direction%2025%20May%202012.pdf>



- iii) taking into consideration whether a factor of zero or some other value should apply to intermittent generation technology types for the purposes of calculating the peak security element of the charge;
- iv) taking into consideration how best the year round element of the tariff might best be structured and levied to more accurately reflect the incremental costs of transmission infrastructure investment from a particular generator on the costs of efficient year round operation of the transmission system (as informed by analysis of the relative costs and benefits of infrastructure investment against operational expenditure); and
- v) taking into consideration how the peak security and year round elements should be applied geographically, particularly having regard to those zones that are, or which may become, dominated by one type of generation technology.

#### Parallel HVDC Links

- 7.43 For taking account of the HVDC links that parallel the AC network, the Direction obliged NGET to include proposals suggestions for modifying TNUoS:
- i) so that where account is taken of the impedance from an HVDC power flow, it is calculated as the average of a ratio of total network boundary rating versus HVDC link rating for all boundaries that the link crosses; and
  - ii) taking into account which costs should be incorporated into the expansion factor calculation for an HVDC link.

#### Scottish Island Links

- 7.44 For appropriately taking account of Scottish Island links that are currently being considered, the Direction obliged NGET to include proposals suggestions for modifying TNUoS:
- i) taking into consideration whether islands classed as 'wider' for charging purposes should have a two part tariff as determined by the sharing element of the proposal;
  - ii) taking into consideration whether islands classed as 'local' for charging purposes should have tariffs consistent with the current methodology for local circuit and local substation tariffs;
  - iii) taking into consider whether, for islands classed as 'wider', the global locational security factor should be used without further modification or whether any lack of redundancy should be reflected in the expansion factor calculation;
  - iv) taking into consideration whether the expansion factor calculation for radial island links comprising HVDC technology should be the same as that for HVDC links that parallel the AC network; and
  - v) taking into consideration whether an anticipatory application of the MITS definition to islands is appropriate and how this could be done.
- 7.45 The CMP213 Original Proposal, addressing the three areas and associated issues required by the Direction (as set out above), was submitted to the CUSC Modifications Panel for their consideration on 29<sup>th</sup> June 2012. The Panel set up a Workgroup to develop and assess the proposed modification and provided Terms of Reference for the Workgroup ([Annex 1](#)).

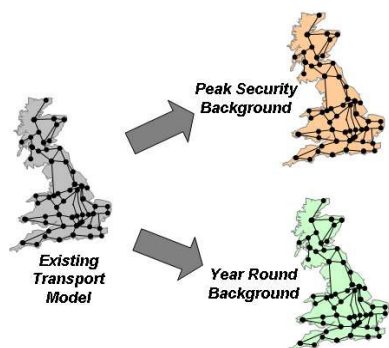
## Annex 8 – Detail of Original Proposal

- 8.1 The following Annex sets out further detail of the Original proposal to address the capacity sharing defect as set out in the modification proposal document.
- 8.2 The proposal makes a number of suggested incremental improvements to the existing Investment Cost Related Pricing (ICRP) methodology used to calculate users' TNUoS charges, as directed in the Authority's Significant Code Review Direction<sup>31</sup>. These incremental improvements can be broken down into; (1) Transport model changes, and (2) Tariff model changes.

### 1) Proposed Changes to the Transport Model

- 8.3 The locational element of the wider TNUoS tariff is calculated through consideration of the relative impact of an additional MW, applied on a nodal basis, within a DC load flow. This is done by first calculating the total network requirements required to accommodate the existing generation and demand at peak followed by the addition of an incremental MW of generation at each node in turn whilst at the same time removing a MW from the centre of the transmission network. This process establishes the nodal incremental network requirements. Currently, the setting of this DC load flow is based on a peak background, with all contracted generation uniformly scaled to match peak demand. In addition, each incremental MW applied is treated equally (i.e. it does not distinguish between generation plant type).

### The Dual Background Approach



- 8.4 Under this proposal, an additional “Year Round” background would be used alongside “Peak Security” considerations, to represent future transmission system development requirements. This Year Round background would group generation into types based on their technology and perceived future operating regimes, and then either flat or variably scale their aggregated

capacity to meet demand in a manner consistent with that outlined in the NETS SQSS, as amended by GSR00932. The level of scaling is shown in Table 1, below, with flat scaling in black, and variable scaling in grey. It should be noted that the Peak Security background sets intermittent generators and interconnectors to zero; i.e. it assumes no contribution from energy sources that cannot be relied upon by the system operator to supply energy at times of peak demand. The scaling factors given in Table 1 are a result of the detailed cost-benefit analysis work undertaken by the NETS SQSS review group as part of GSR009 to represent transmission network investment requirements for year round conditions in a single snapshot. It is proposed that the scaling factors given in Table 1 are reviewed in line with changes to the NETS SQSS. This approach of linking

<sup>31</sup> <http://www.ofgem.gov.uk/NETWORKS/TRANS/PT/Documents1/Final%20direction%2025%20May%202012.pdf>

<sup>32</sup> NETS SQSS Review of Required Boundary Transfer Capability with Significant Volumes of Intermittent Generation – GSR009 Consultation Document v1.0 11 June 2010; <http://www.nationalgrid.com/NR/rdonlyres/E22B1547-D4CC-4F88-AEEF-C76305718C25/41720/GSR009SQSSConsultation.pdf>



to the NETS SQSS is consistent with the existing link between TNUoS charging and the security standards set out in Section 14 of the CUSC.

Generator Type	TEC in Transport Model	Current Methodology	Peak Security Background	Year Round Background
Intermittent	5,460	65.5%	0%	70%
Nuclear & CCS	10,753	65.5%	72.5%	85%
Interconnectors	3,268	65.5%	0%	100%
Hydro	635	65.5%	72.5%	66%
Pumped Storage	2,744	65.5%	72.5%	50%
Peaking	5,025	65.5%	72.5%	0%
Other (Conv.)	61,185	65.5%	72.5%	66%

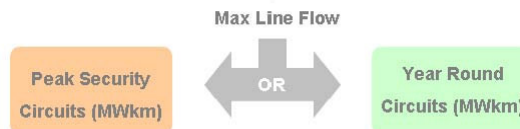
*(source 2011/12 Transport Model)*

**Table A8.1 – Example dual background generation scaling factors**

- 8.5 In the above table, peaking plant is defined as oil and OCGT technologies and Other (Conv.) represents all remaining conventional plant not explicitly scaled. In the event that a power station is made up of more than one technology type, the type of the higher Transmission Entry Capacity (TEC) would apply.
- 8.6 Utilising the Transport Model from 2011/12 as an example, generation would be scaled using the factors set out in Table A5.1, above, to create two balanced DC load flow models. Combined these models would represent the total network requirements for existing generation and demand, as the single background flows do in the existing approach. It should be noted that, consistent with the current DC load flow model, no circuit ratings would be considered, and no level of redundancy would be assessed at this stage.

**Allocating Incremental Network Requirements**

8.7 Flows on individual transmission circuits in these two models would subsequently be compared. As part of the original modification proposal, the background giving rise to the higher flow on a circuit would be considered to be the ‘triggering criterion’ for future investment. Triggering criteria for all circuits in the model would then be ascertained and recorded; i.e. circuits will be tagged as either Peak Security or Year Round. In the rare event that both triggering criteria give rise to identical circuit flow the Peak Security background would be taken as the triggering criterion. This reflects the order of priority given to these two backgrounds when considering transmission investment requirements.



- 8.8 As outlined above, the current ICRP methodology uses an incremental MW applied to a DC load flow at each node in turn (and removed at the reference node), in order to establish the effect of that additional MW on the transmission system as a whole. Under the proposed methodology, this assessment would be carried out at each node in turn for both Peak Security and Year Round backgrounds.
- 8.9 Currently a single reference node is selected. This selection is arbitrary as, due to the re-referencing process, only the relative locational charges are of relevance. However, due to the use of two background criteria in the Transport Model, the re-referencing process would require minor modifications. In order to simplify this revised re-referencing process as much as possible, it is proposed to use a distributed reference node rather than a single reference node. This would effectively split the incremental

1MW removed at the reference node from a single point to proportions on each demand node in the Transport Model. The proportion allocated to a given node would be based on the background nodal demand in the model. For example, with a GB demand of 60GW in the Transport Model a node with a demand of 600MW would contain 1% of the distributed reference node (i.e. 0.01MW).

8.10 On a transmission node by node (i.e. substation by substation) basis, the impact of the incremental MW (i.e. the net change in power flow) would need to be recorded for each circuit's triggering criterion. Therefore, an incremental MWkm would need to be established for each node and attributed to the appropriate circuit triggering criterion; i.e. Peak Security or Year Round. This process results in a set of Peak Security MWkm and Year Round MWkm which combined amount to approximately the same level of total incremental MWkm as the existing ICRP approach. For the 2011/12 Transport and Tariff model, net Peak Security MWkm represent 13.5% of the total network incremental MWkm.

8.11 An overview of the proposed process is given below in Figure A8.1.

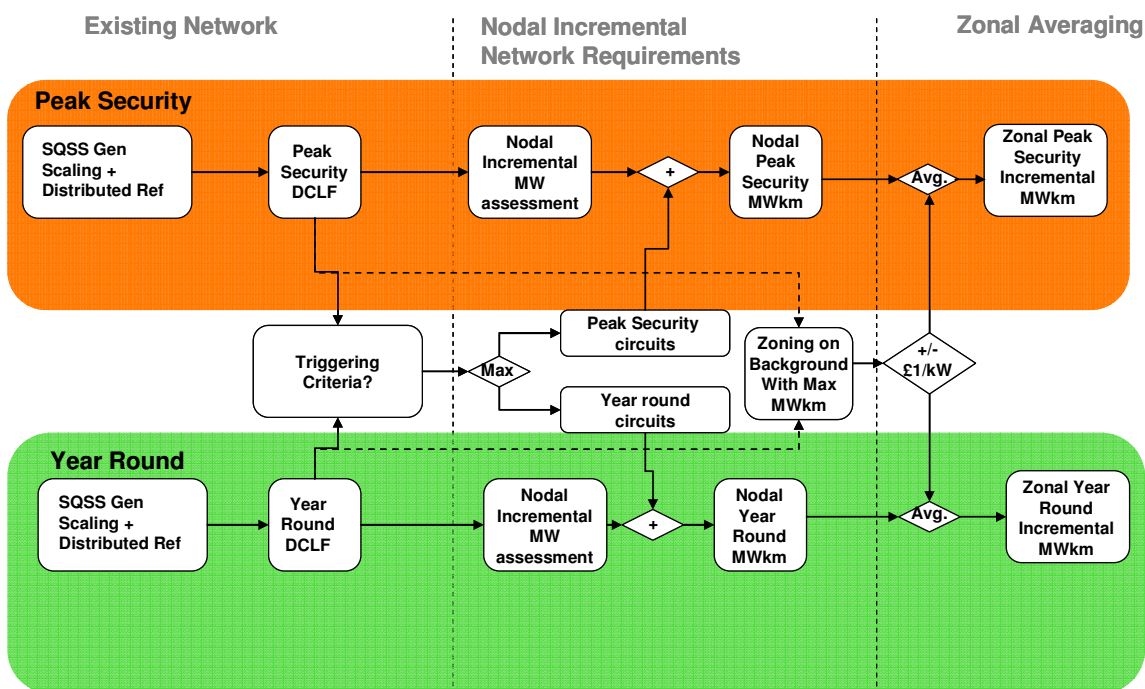


Figure A8.1 – Illustrative Dual Background Transport Model Logic

8.12 Using the expansion constant (£/MWkm) data from the Tariff Model, the nodal incremental MWkm are subsequently averaged into zones.

Generation Zoning Criteria

8.13 The current methodology for setting generation TNUoS tariff zones requires that these zones should be electrically and geographically proximate and contain relevant nodes whose wider incremental costs are all within +/-£1.00/kW across the zone (i.e. a £2.00/kW spread). Under this proposal it is recommended that zoning assessment is undertaken in exactly the same manner as now, utilising the background with the most MWkm (i.e. the Year Round background) and that it continues to be undertaken such that wider incremental costs (i.e. marginal kilometres) are within +/-£1.00/kW (i.e. +/-50km with EC=£10/MWkm and SF=1.8). All marginal kilometres from the Year Round background will be considered to ensure a full set of background conditions is considered. Unless there are exceptional circumstances, generation charging zones are normally fixed for the duration of each Transmission Price Control Review.

## 2) Proposed Changes to the Tariff Model

- 8.14 As in the current version of the Transport and Tariff Model, the zonal incremental MWkm are passed from the Transport Model into the Tariff Model in order to calculate the locational differentials in the tariff. In the case of this sharing strawman two sets of MWkm are passed into the Tariff Model representing both the Peak Security and Year Round backgrounds as set out above.
- 8.15 This proposal intends that the zonal incremental MWkm for Peak Security and Year Round backgrounds be converted into tariffs, which would ultimately lead to the creation of two wider locational tariff components in addition to the residual. Therefore, under this proposal, a generator's wider TNUoS tariff would be comprised of the following three components;
- i) Peak Security,
  - ii) Year Round,
  - iii) Residual
- 8.16 The original proposal assumes that this sharing of capacity only occurs by generators on the wider transmission network. Therefore, a generator's local substation and local circuit tariff and demand tariffs would not generally be affected by the proposed changes.

### **Generation Local Tariffs**

- 8.17 Local tariffs can consist of a local substation tariff and a local circuit tariff. National Grid's proposal will not to alter the local substation tariff calculation, and therefore will have no impact on local substation charges.
- 8.18 The boundary between wider and local TNUoS generation charges is defined in section 14 of the CUSC through the charging definition of a MITS node, with generators being a liable for a local circuit charge representative of the local marginal km on transmission circuits connecting it to the nearest MITS node.
- 8.19 The Original proposal seeks to alter the charging definition of MITS node to include all radial transmission circuits as local circuits. This would provide for an appropriate treatment of wider sharing following Workgroup concerns, and also ensure consistency of approach for island connections with other radial transmission circuits.
- 8.20 The proposed revised charging definition of a MITS node would be;
- Grid Supply Point connections with 2 or more transmission circuits connecting at the site; or
  - connections with more than 4 transmission circuits connecting at the site.
- Other than where export from a Power Station to the main National Electricity Transmission System is dependent on a single transmission circuit.
- 8.21 The Original proposal accepts that there may be counter correlation of generation outputs on such local circuits, and that a Transmission Owner may account for this in the design of a local transmission circuit by building less transmission capacity. This is achieved through the introduction of a Counter Correlation Factor (CCF) which is derived from the formula below;

$$CCF = \frac{D_{\min} + T_{cap}}{G_{cap}}$$

Where;  $D_{\min}$  = minimum annual net demand (MW) supplied via that circuit in the absence of that generation using the circuit

$T_{cap}$  = transmission capacity built (MVA)

$G_{cap}$  = aggregated TEC of generation using that circuit

- 8.22 The CCF would be used as a multiplier to the local circuit charge for generators for the relevant transmission circuit within the local circuit charge. The CCF would be capped at 1.0.
- 8.23 Due to the categorisation of circuits as either Peak Security or Year Round in the Transport Model, there can be an indirect impact on local circuit tariffs in instances where local circuits are not purely radial in nature. It is proposed that all local circuits will have a Year Round triggering criterion, so as to avoid any perverse incentives in the choice of level of security for design variations on local circuits.
- 8.24 There would be no impact on offshore local tariffs.

### ***Demand Tariffs***

- 8.25 As the incremental impact of demand at a node is calculated as the equal and opposite of generation, demand tariffs are also consequentially calculated using the Peak Security and Year Round backgrounds as outlined above. Demand tariffs, although also split into Peak Security and Year Round components in order to complete the overall tariff calculation, would remain largely unaffected as both these components along with the residual are all charged on the same basis. The reason chargeable capacity for the Peak Security and Year Round elements of the demand tariff remain the same, unlike those for generation, is that the very nature of demand is different within the commercial arrangements. Unlike individual generating units connected directly to the transmission network, each having explicit firm access rights and specific measurable characteristics, demand is amalgamated to Grid Supply Point Groups with implicit access rights resulting in its homogeneous characteristics.
- 8.26 Hence, setting out each individual demand tariff component times the chargeable capacity would result in the same charge as combining the tariff components and subsequently multiplying by chargeable capacity. As such, combining the tariff components to achieve one £/kW tariff maintains simplicity in this area. This is not possible for generation tariffs as the chargeable capacity is necessarily different for each component.

### **Calculating Wider Locational Tariffs**

- 8.27 The following section provides an overview of the Tariff Model process and describes the proposed approach to each of the wider locational tariff components for generation in greater detail.
- 8.28 It is proposed that locational tariffs are derived, as per the existing transmission charging methodology, from the nodal marginal km output of the Transport Model, and the associated zoning exercise. However, as there are two sets of generation MWkm created in the Transport Model corresponding to the Peak Security and Year Round criteria there would

ultimately be two wider locational tariff components for generation (as described above).

8.29 Conversion from zonal incremental MWkm to unadjusted tariffs follows the existing process through multiplication by the expansion constant and locational security factor. The subsequent re-referencing process maintains a 27% of revenue from generation and 73% of revenue from demand split on both the Peak Security and Year Round components separately. This individual re-referencing is necessary as, whilst both these wider locational tariff components are charged based on a generator's TEC (i.e. MW capacity), the actual application for specific users will depend on that user's characteristics and is different for both components. This process is illustrated, below, in Figure A8.2.

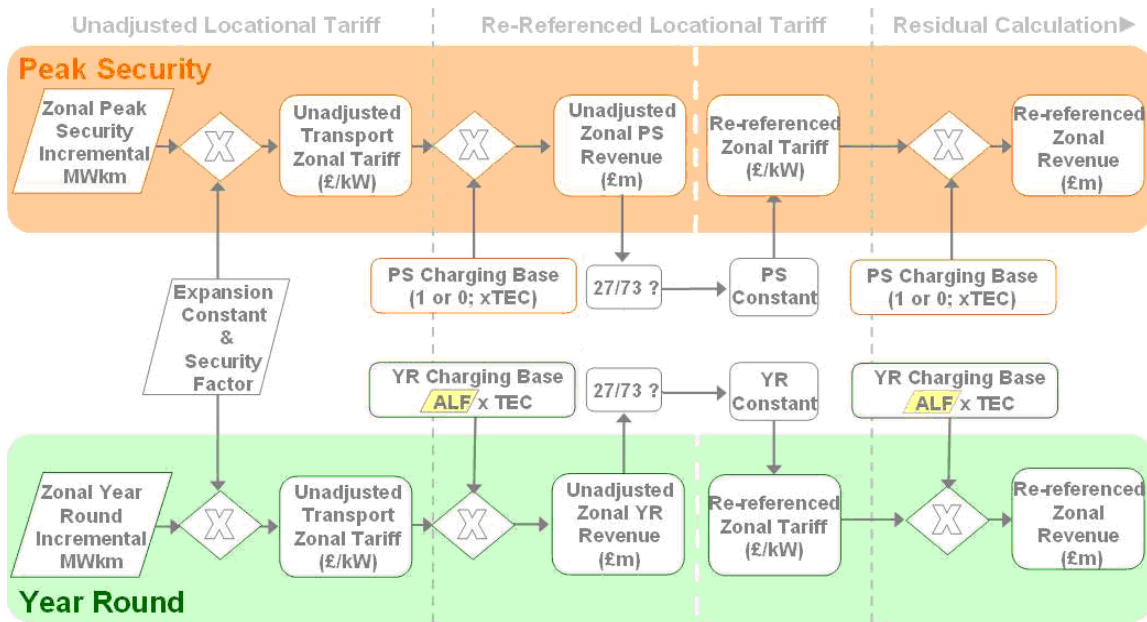


Figure A8.2 – Illustrative Tariff Model Logic: Part 1

8.30 Finally, the re-referenced zonal tariff components are used to calculate the proportion of Maximum Allowed Revenue (MAR) that remains to be collected from the wider tariff for both generation and demand. This is done through the calculation of a residual component for each. The remainder of the process set out in Figure A8.2 for generation tariffs is illustrated in Figure A8.3, below.

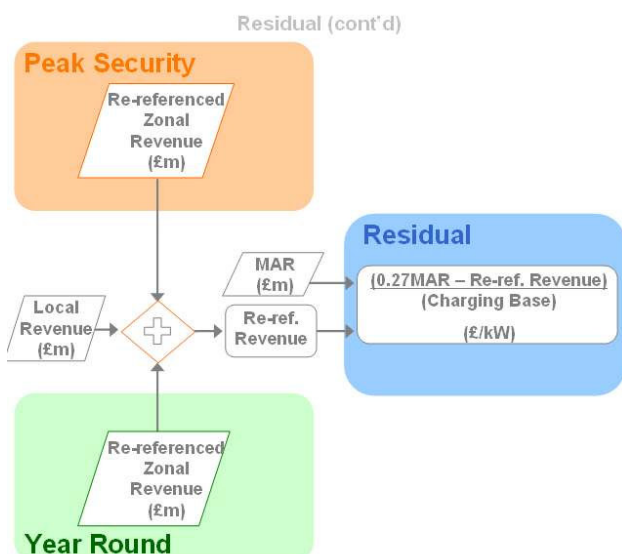


Figure A8.3 – Illustrative Tariff Model Logic: Part 2

**Peak Security Component**

- 8.31 It is proposed that the Peak Security tariff component is only levied on those generators that have a high probability of operating at significant volumes during peak demand periods, consistent with the Security and Quality of Supply Standard (SQSS). As a result of changes to the SQSS through GSR-009, transmission network development for Peak Security requirements is triggered by such generation and hence it is proposed that it is appropriate that this component of the wider locational tariff be directed towards this generation. As noted above, for the generation background in a 2011/12 model, the net Peak Security MWkm represents 13.5% of the total incremental MWkm.
- 8.32 The revenue from a specific generator due to the Peak Security locational tariff is equal to that component of the tariff multiplied by the forecast generation capacity. This also needs to be multiplied by the appropriate Peak Security flag. The Peak Security (PS) flags indicate whether a generation type contributes to the need for transmission network investment at peak demand conditions. As such, they are consistent with the background generation scaling used in the Peak Security Transport Model assessment (see Table A8.1 above) and the SQSS. These flags are given below in Table A8.2.

Generation Type	PS Flag
Intermittent	0
Other	1

**Table A8.2 – Peak Security Flags**

- 8.33 The revenue recovery from the Peak Security component for a given generator is calculated as;

$$UZRR_{PS} = G_{TEC} \times F_{PS} \times UZT_{PS}$$

Where;

$UZRR_{PS}$  = Unadjusted Zonal Revenue Recovery from Peak Security component

$G_{TEC}$  = Forecast generation capacity

$F_{PS}$  = Peak Security flag appropriate to that generator type

$UZT_{PS}$  = Unadjusted Zonal Peak Security Tariff (£/kW)

### **Year Round Component**

- 8.34 National Grid's analysis of the relationship between load factor and incremental transmission constraint costs has indicated a broadly linear relationship largely independent of generation technology (although it is noted that this can be further refined to account for other factors and that this is reflected in some of the potential alternatives developed by the Workgroup). It is therefore proposed that a generator's specific output over an extended period of time is a reasonable reflection of the assumption used in transmission network planning timescales and thus the transmission investment it triggers. It follows that the Year Round tariff component for a generation user could be based on the specific output of that generator over time.
- 8.35 In order to maintain a simple and transparent approach, it is proposed that historic generation annual load factors (ALF) be used as scaling factors which more accurately represent the impact of an incremental MW of a given generation type to the need for network investment in under the Year Round background.

- 8.36 The ALF is taken to be indicative of assumptions made about a generator's operating regime in transmission planning timescales, and therefore its effect on transmission investment required for year round operation of the system. As such it is not intended to be an accurate reflection of a generator's actual output over a particular twelve month charging period. Whilst several potential options exist for the calculation of the ALF based on forecast or historical load factor, this proposal puts forward a fixed, historical based approach that precludes the need for an end of year reconciliation. The benefits of this fixed approach are added certainty and stability as a result of increased predictability of tariffs and accuracy of within year revenue collection. In addition, of all the alternatives considered, this approach is deemed most representative of assumptions made in transmission network planning timescales.

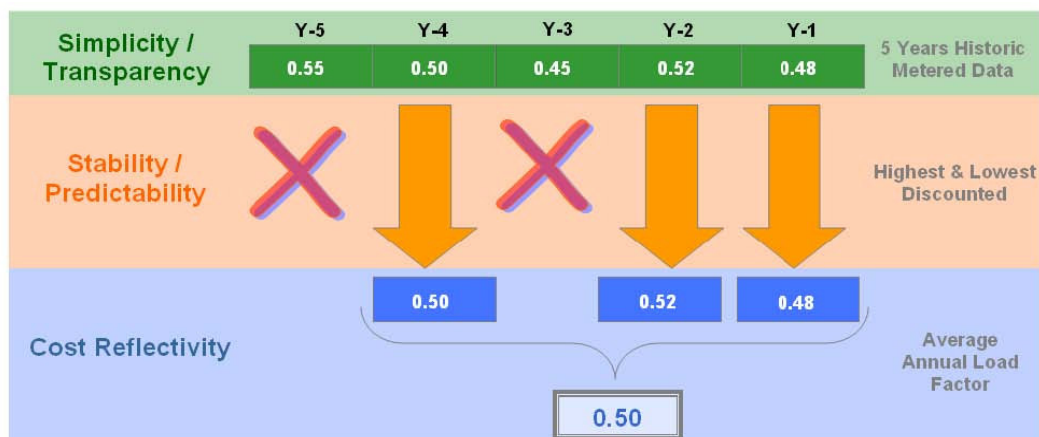
#### Calculation of User Specific ALF

- 8.37 Historic annual load factors would be calculated (for each power station) for each of the last five complete financial years (years -5 to -1) (with the highest and lowest load factors removed) using the formula below;

$$ALF = \frac{MWh \text{ - output}}{TEC \times 8760}$$

- 8.38 The TEC figure used in each calculation would be the highest TEC applicable to that power station for that financial year. The MWh output figure would be derived from the maximum of FPN or actual metered output in each Settlement Period (i.e. published historic user data). The benefit of FPN data is that it better represents a generator's intended system usage as it accounts for some SO constraint actions taken to manage the system. However, it should be noted that longer timescale SO actions would not be captured. The use of FPN data may also require the development of a new process to obtain validated historic FPN data, as this data is not currently used for settlement purposes for all users.
- 8.39 Once all five historic load factor figures have been calculated they would be compared, and the highest and lowest figures are discarded. The discarding of these outermost figures ensures that the final ALF is representative of an indicative operating regime for a particular generator as would have been assumed when planning network investment, and has not been influenced by atypical behaviours. Such behaviours can range from unseasonal weather conditions through to response to System Operator instructions. In addition, such an approach increases the stability of charges year on year.
- 8.40 The ALF, to be used for transmission charging purposes, is calculated as the average of the remaining three historic load factor figures. The process, with example figures, is illustrated in Figure A8.4, below.





**Figure A8.4 – Proposed Calculation of Annual Load Factor (ALF)**

- 8.41 In the event that only four years of complete metered data are available for a generator then the higher three years load factor would be used in the calculation of ALF. In the event that only three years of complete metering data are available then these three years would be used.
- 8.42 Due to the aggregation of metered data for dispersed generation (e.g. cascade hydro schemes), where a single generator BMU consists of geographically separated power stations, the annual load factor would be calculated based on the total output of the BMU and the overall TEC of the BMU.
- 8.43 In the event that there are not three full years of a generator’s output available, missing historical information would be replaced by generic data for that generator type to ensure three years of information are available for the user.

Derivation of Generic Generator Data

- 8.44 Generic data would be derived from the average annual output of all GB generation of a particular fuel type over the last five years, using an identical methodology to that used for the user specific calculation. The illustrative fuel type categories and data are listed in Table A8.3, below;

Fuel Type	Generic Load Factor
Biomass	N/A
Coal	43%
Gas	57%
Hydro	12%
Nuclear	60%
Oil	2%
Pumped Storage	15%
Wind	16%

**Table A8.3 – Fuel Type Categories to be used to derive generic load factor**

- 8.45 For new and emerging technologies, where insufficient data is present to allow a generic load factor to be developed from historic information, a generic load factor could be produced by National Grid using an agreed forecast modelling tool. For new generation connecting mid-year, a prorated ALF would be derived using the figures in Table A8.3. When used for this purpose, it is assumed that the output of the generator is apportioned evenly across a twelve month period.
- 8.46 Generic load factors would be reviewed annually in the period November – December (i.e. at the same time as user specific ALFs) and would be published, in a form similar to Table A8.3 above, within the Statement of Use of System Charges (the Charging Statement). ALF forecasts would be

provided to all generation users at the same time as draft TNUoS tariffs are published.

- 8.47 The revenue recovery from the Peak Security component for a given generator is calculated as;

$$UZRR_{YR} = G_{TEC} \times ALF_{gen} \times UZT_{YR}$$

Where;

$UZRR_{YR}$	= Unadjusted Zonal Revenue Recovery from Year Round component
$G_{TEC}$	= Forecast generation capacity
$ALF$	= Annual Load Factor specific to that generator (as set out above)
$UZT_{YR}$	= Unadjusted Zonal Year Round Tariff (£/kW)

Re-referencing of Unadjusted Transport Zonal Tariffs

- 8.48 Presently, for both generation and demand users, zonal marginal km (ZMkm) are multiplied by the expansion constant and the global security factor (SF) to give an unadjusted zonal transport tariff. These unadjusted tariffs are multiplied by the expected total metered triad demand and total generation TEC capacity (MW) to calculate the initial revenue recovery. These initial revenue recoveries are then corrected to obtain a 27:73 split in revenue collection between generation and demand respectively. This is achieved through the calculation of a single constant, C, which is then added to the total zonal marginal km for generation and demand as below;

$$\sum_{Gi=1}^n [(ZMkm_{Gi} + C) \times EC \times SF \times G_{Gi}] = CTRR_G$$

$$\sum_{Di=1}^{14} [(ZMkm_{Di} + C) \times EC \times SF \times D_{Di}] = CTRR_D$$

Where EC = expansion constant  
 LSF = locational security factor  
 G = generation within [a] [each] zone  
 D = demand within [a] [each] zone  
 CTTR = 'generation / demand split' corrected transport revenue recovery

- 8.49 In order to ensure the aforementioned calculation remains robust in a methodology with two different locational elements and a residual component of the tariff, each with different charging bases, a distributed reference node is utilised. This ensures that the tariff is reference node<sup>33</sup> invariant and that revenue recovery is not transferred between tariff components. In addition it is proposed that each locational revenue component would not be re-referenced and the proportion of revenue collected from each tariff element arising from the Transport model would be maintained. The combination of a distributed reference node and two locational tariff elements that are not referenced ensures that the locational signal remains robust, whilst leaving the residual element of the tariff to ensure a correct G:D split in revenue recovery.

Relevant Chargeable Capacities for Generator Charge Calculations

- 8.50 It is proposed that there is no change to the existing definitions of chargeable capacity. Hence, the chargeable capacity for power stations with positive wider generation tariffs will be the highest TEC (MW) applicable to that power station for that Financial Year. The chargeable capacity for power stations with negative wider generation tariffs would

<sup>33</sup> The reference node is required to ensure balancing of the incremental MW DC load flow analysis in the Transport model.

continue to be the average of the capped metered volumes during three settlement periods of the highest and next highest metered volumes which are separated from each other by at least 10 Clear Days, between November and February of the relevant Financial Year inclusive. These settlement periods do not have to coincide with the demand Triad.

The Residual Component of the Tariff

8.51 As with the existing process there is still a requirement for a residual charge in order to ensure the necessary revenue recovery. Assuming that the revenue to be collected from generation users is 27% of the Maximum Allowed Revenue, the required revenue to be recovered from the generation residual charge can be calculated as;

$$R_{RG} = 0.27MAR - R_{LS} - R_{LC} - R_{PSG} - R_{YRG}$$

Where;

- $R_{RG}$  = required revenue from generation residual charge
- MAR = Maximum Allowed Revenue
- $R_{LS}$  = revenue from local substation charges
- $R_{LC}$  = revenue from local circuit charges
- $R_{PSG}$  = revenue from Peak Security locational charges
- $R_{YRG}$  = revenue from Year Round locational charges

8.52 The £/kW generation residual component of the tariff can then be calculated from the division of this required revenue by the chargeable generation capacity of connected generation. This process is illustrated in Figure A8.2, above.

**Final Generation Tariff**

8.53 Ultimately, each generator will be liable for the tariff components illustrated in Figure A8.5, below. These tariff components will be levied on the relevant chargeable capacities as outlined above.

**Conventional Tariff =**



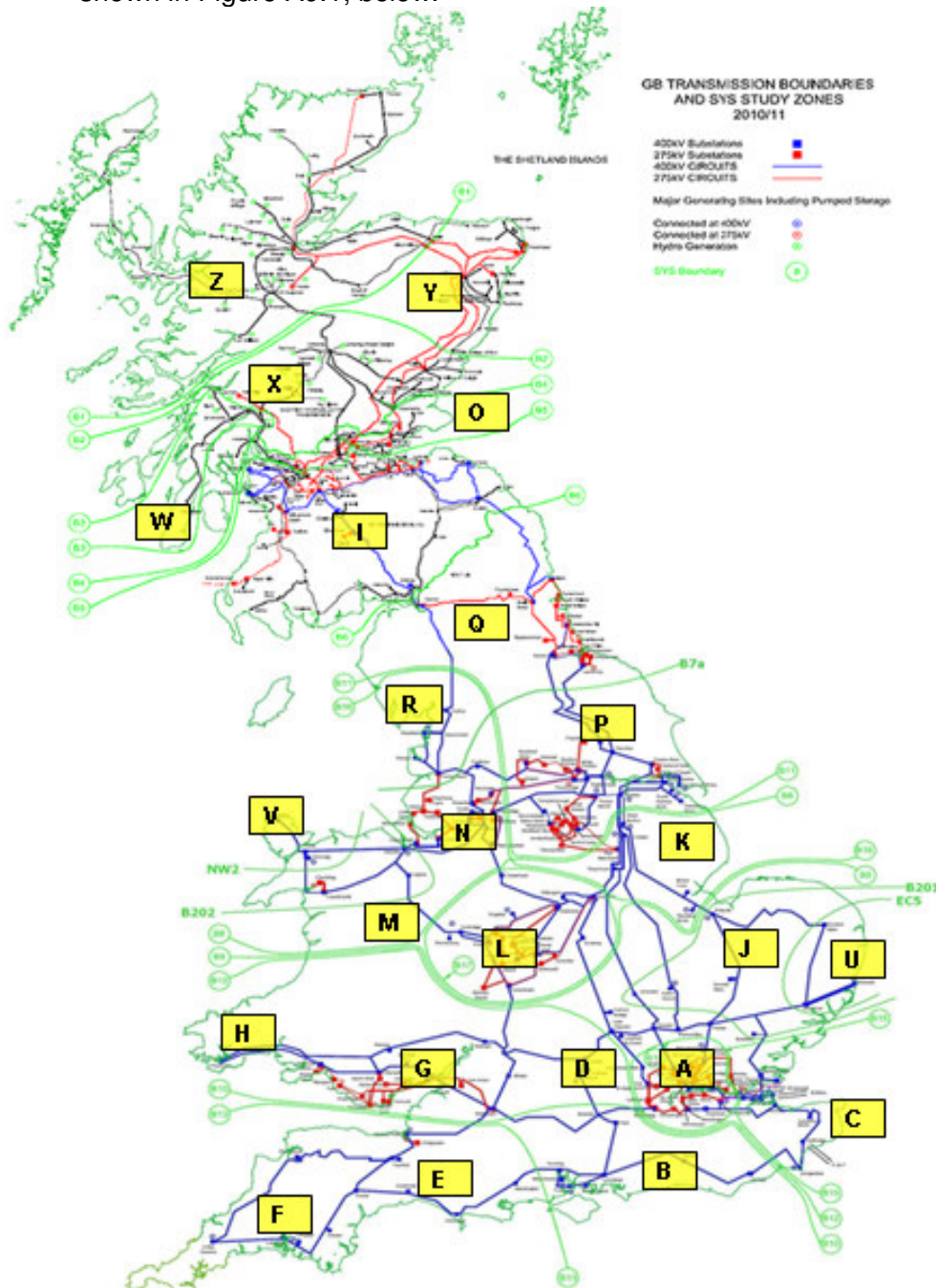
**Intermittent Tariff =**



**Figure A8.5 – Final Proposed Tariff Components**

- 9.1 The graphs that follow represent analysis undertaken using the interface for the Electricity Scenario Illustrator (ELSI) model created for the CMP213 process. ELSI is a Microsoft Excel based model, created by National Grid, which does not require any additional plug-ins or software to operate. It is a simple representation of the Great Britain electricity market, which performs an optimum economic dispatch and re-dispatch of generation to meet demand and rectify transmission network constraints in the most cost effective manner. It was initially devised as part of the RIIO Transmission Price Control Review process to demonstrate to network users the consequences of National Grid's transmission investment plans.
- 9.2 The interface developed for CMP213 utilises the ELSI functionality to explore the relationship between generation annual load factor and annual incremental impact on transmission system constraint costs, which is the basis of the Original proposal, for different generation technology types and location. This interface was developed specifically for the Project TransmiT and CMP213 process to promote transparency and to allow stakeholders to conduct their own analysis of this relationship.
- 9.3 The generation annual load factors and constraint costs are obtained by:
- i) Calculating annual GB wide constraint costs for a given scenario of transmission network capability, generation capacity and demand;
  - ii) Incrementing the capacity of a generation technology, in a given SYS zone and re-calculating the impact on annual GB constraint costs. The difference between (ii) and (i) is the incremental impact on constraint costs; and
  - iii) Calculating the annual load factor of the zonal generation technology using the unconstrained dispatch (equivalent to Final Physical Notifications)
- 9.4 The incremental impact on constraint costs against the annual load factor of each generation type per SYS network zone is then presented in the form of a graph. User defined data sets and results can be saved for future reference.
- 9.5 The numerous generators, grid supply points, substations and circuits that comprise the GB electricity transmission system are represented in the ELSI model by dividing the transmission network into a series of zones separated by transmission boundaries. Within each SYS zone, the total level of generation and demand is modelled such that each zone will contain (i) a total installed capacity of generation (GW) of various fuel types (nuclear, CCGT, onshore wind, etc.) and (ii) a percentage of overall GB demand. As generation rarely equals demand in a given zone a level of connectivity is required to allow the transmission system to balance overall (i.e. total GB generation = total GB demand). The boundaries, which represent the actual transmission circuits facilitating this

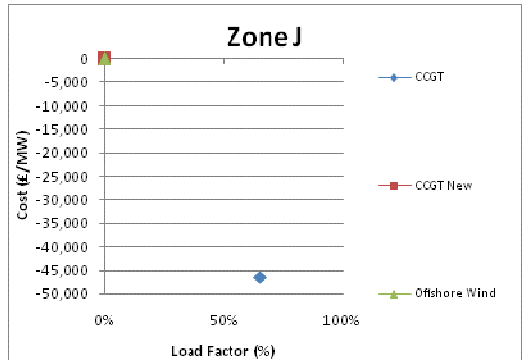
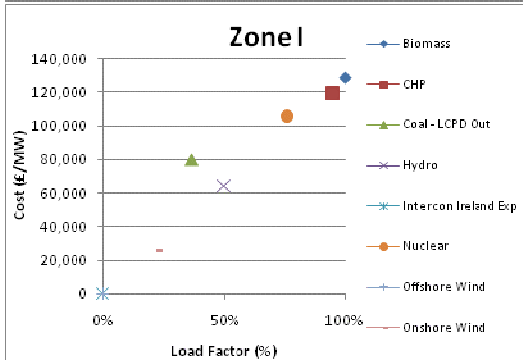
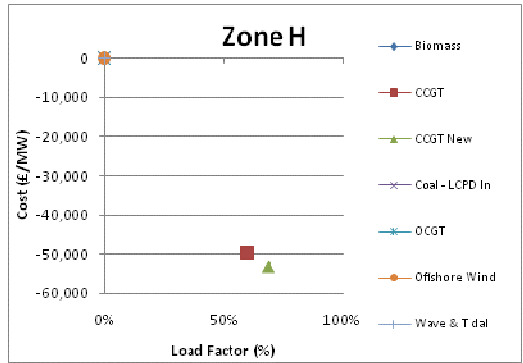
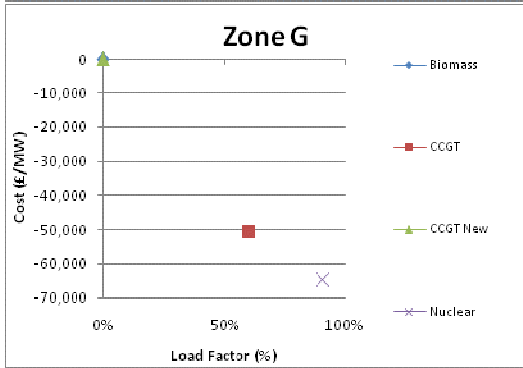
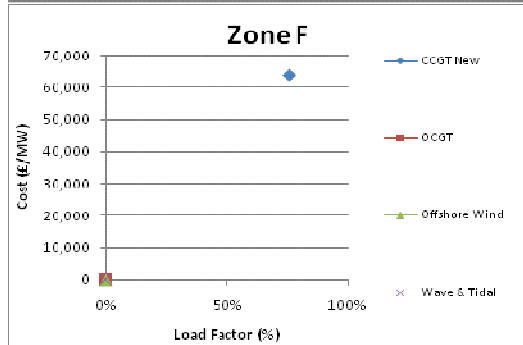
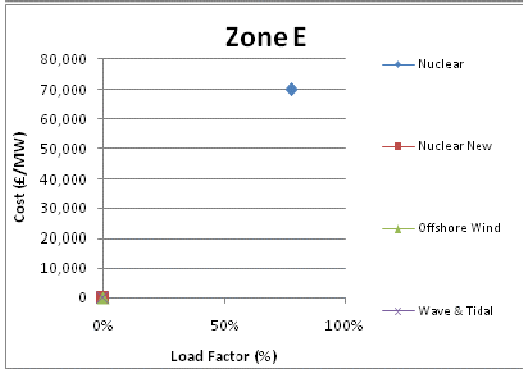
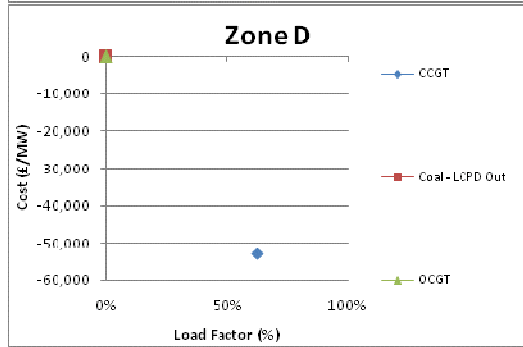
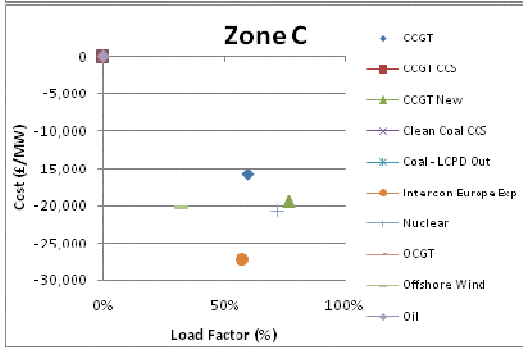
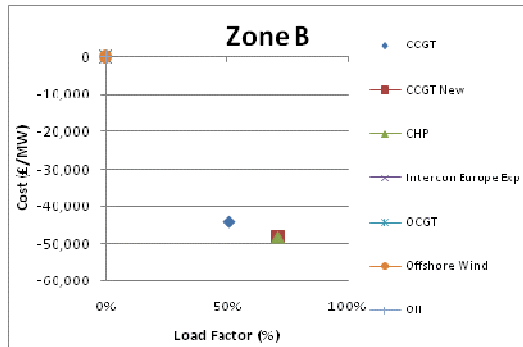
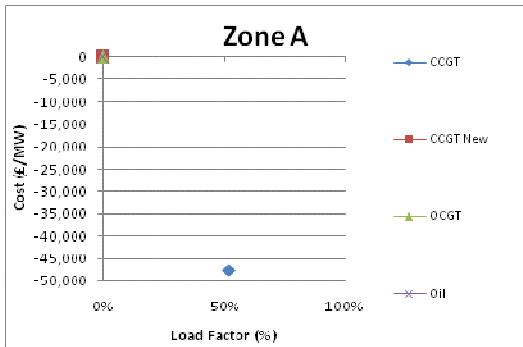
connectivity, have a maximum capability (expressed in GW) that restricts the amount of power which can be transferred across them. A map of the geographical location of the actual zones used within the ELSI model is shown in Figure A9.1, below.

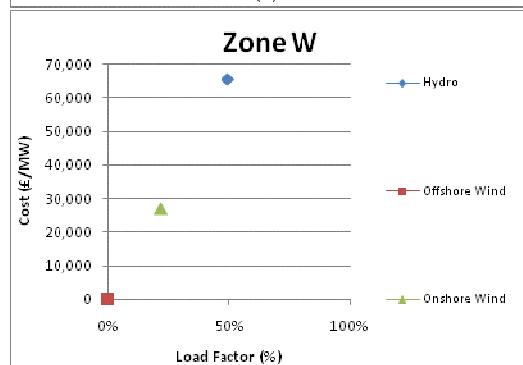
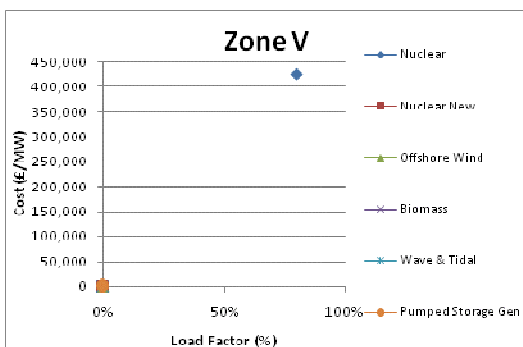
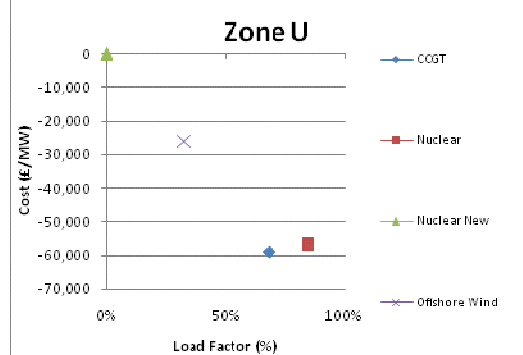
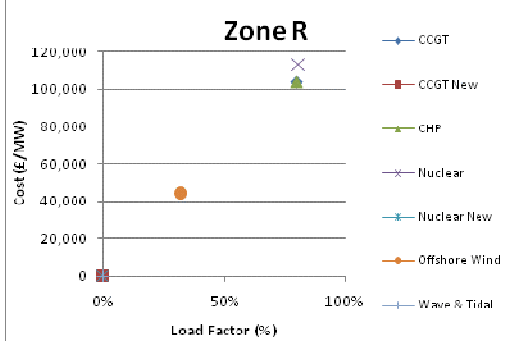
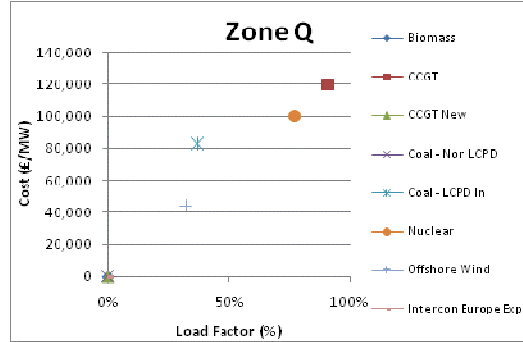
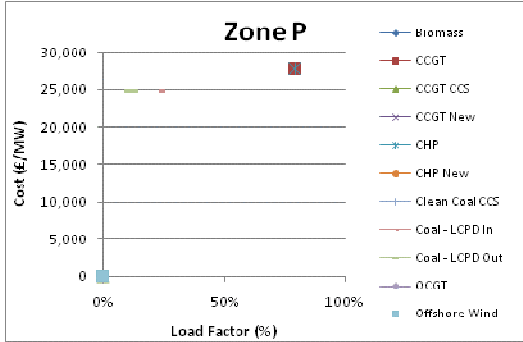
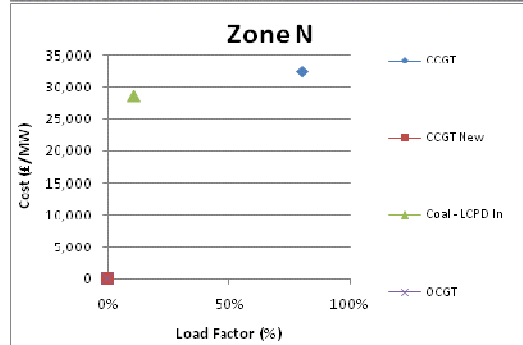
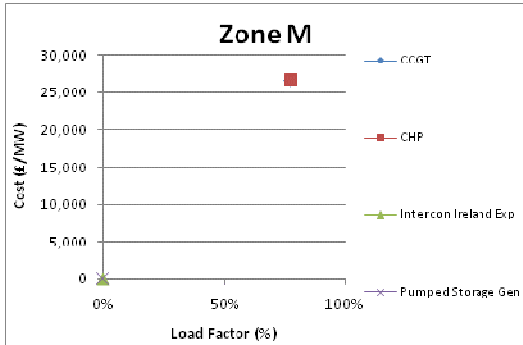
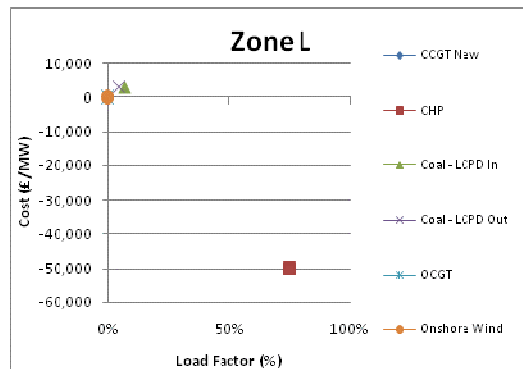
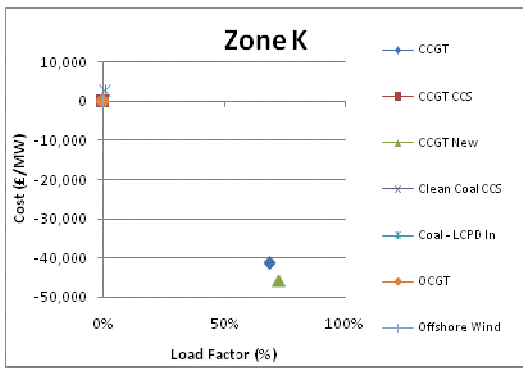


**Figure A9.1 – Geographical Map of ELSI Zones**

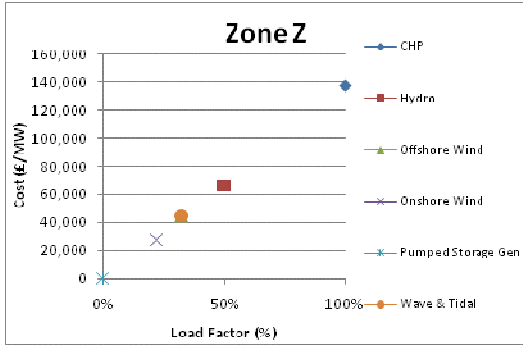
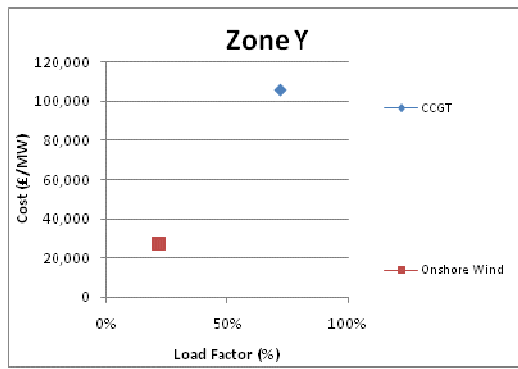
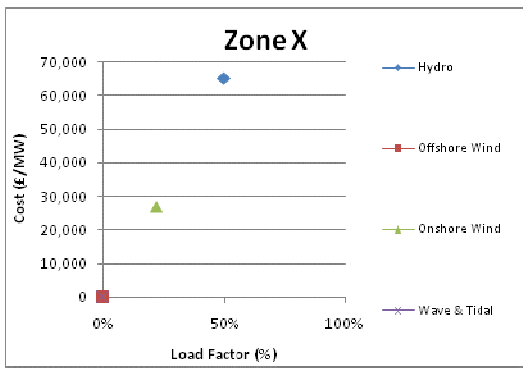
9.6 The following analysis was undertaken on a 2011/12 generation and demand background within the ELSI market model. As the Original proposal would utilise the relationship between transmission network long run costs (i.e. network costs) and short run costs (i.e. re-dispatch costs), which occurs when the transmission network is planned to its optimum capacity the analysis was undertaken on a transmission network that is as far as possible sized optimally. Whilst the assumption of optimum transmission network boundary capability may not represent reality (due to historic network build, the lumpy nature of transmission investment and the effect of connect and manage) this approach is consistent with the existing ICRP assumption that does not account for spare capacity or under capacity in the transmission network.

# Analysis of Annual Load Factor vs. Annual Incremental Costs Using ELSI









## Annex 10 – ALF and Changes to Plant Running Profiles

- 10.1 Members of the CMP213 Workgroup have raised concerns over the “backwards looking” nature of the proposed sharing factor for generation – i.e. Annual Load Factor (ALF) – approach set out in the Original proposal. The ALF methodology approach takes a generator’s load factor for each of the last five (charging) years, removes the two extreme values (i.e. highest and lowest) and then calculates a mean average of the three remaining values. The resulting figure is then used as part of the calculation to determine the given generator’s transmission TNUoS charge for the following charging year.
- 10.2 A key concern is that the proposed ALF methodology approach does not take account of situations where a generating plant is subject to a change in its role in the wholesale electricity market. There are two high-level types of change in a generating plant’s role:
- Periodic step changes:
    - These changes may occur on a regular (e.g. change in season) or irregular (external influence) basis;
    - Regular changes are more likely to “average out” (charging) year to (charging) year, meaning the generator would only be subject to short-term gains and losses; and
    - Irregular changes are less likely to average out and could be unidirectional;
  - One-off step changes:
    - These changes will tend to have a unidirectional effect on a plant’s load factor that will not change in the foreseeable future;
    - The event may be predictable, such as the date that a new regulation comes into force or a fuel supply contract ends; and
    - It could also be unpredictable, such as a catastrophic plant failure.
- 10.3 The remainder of this Annex considers a number of scenarios where such issues may arise. The points raised are not intended to compare the ALF methodology approach against the charging principles in place today. The intention of the discussion was in this Annex is to highlight, and spark record the debate within the CMP213 Workgroup on a number of scenarios where the ALF methodology approach may be considered less reflective of how generation Users contribute to the creation of constraints on the transmission system. This allowed the Workgroup to determine which scenarios are considered desirable and which scenarios are considered anomalies and thereby require mitigation.

### Change to input costs

#### Market prices (e.g. fuel switching and carbon price)

##### *Description*

- 10.4 The cost of generation depends upon a number of variable input prices, such as fuel costs, the cost of carbon, SO<sub>x</sub> and NO<sub>x</sub> permitting, etc. These input prices are variable due to their value being set by market forces (supply and demand). As different generating plant types have different fuel and emission permitting requirements, their relative positioning in the merit order will “switch” over time. An example often quoted is fuel switching between gas and coal fired generators.

##### *Concern*

- 10.5 As ALF will “lag” behind (charging) year-on-year changes in a generating plant load factor, it may take a number of years (with CMP213) for transmission TNUoS charging to catch up (if at all) with actual within-year running profiles of that plant. This effect may average out where fuel switching occurs on a regular and steady basis. However, should there be a dominant fuel type over prolonged periods with only occasional fuel switching over short periods of time (e.g. fuel supply issues over a winter period), then such single-year occurrences may be overlooked by the ALF methodology approach.

#### End of long-term fuel supply contracts and PPAs

##### *Description*

- 10.6 Long-term fuel contracts may provide generators with a level of protection against the volatility of fuel prices. The cost of purchasing fuel may be based on a discounted reference price or linked to a basket of indices. Over time, the cost of the contract holder’s fuel may diverge and converge with market prices, providing them with an advantage (or disadvantage) against those that are price takers in their respective fuel market. Some fuel supply contracts may also contain “take or pay” provisions, meaning that generators must take delivery of a certain volume of fuel, regardless of the price. The generator must decide which action provides the best financial outcome: sell the fuel or produce power, potentially at a cost to the business.
- 10.7 PPAs provide longer-term certainty to power producers that there will be an off-take of the power they produce. Such contracts may guarantee a minimum number of running hours or capacity usage. An example of the latter is where a generator has CHP capability and is contracted to deliver a rate of heat to an adjacent industrial application.

##### *Concern*

- 10.8 If such contracts end and are not replaced, the generating plant will be forced to trade on a merchant basis. Depending upon where the generating plant sits in the merit order (prior to and after the contract ends), there could be a significant disparity between a generator’s transmission TNUoS charge and its use of the transmission system. Whilst the ALF methodology approach will catch up over time, the generator’s TNUoS charges may not average out due to the generating plant never returning to higher, prolonged annual load factors.

#### **Plant lifecycle**

##### Lifecycle transition

##### *Description*

- 10.9 Advances in generation technology (leading to higher fuel efficiencies) mean that generators of the same asset class will have different merit order positions. The majority of plant can expect its position in the merit order to change over time (i.e. over its lifecycle). This change is generally unidirectional, until such time as investment is made in the generating plant to reverse or slow the trend.

##### *Concern*

- 10.10 Historically, movement from a high merit position to an out-of-merit position has been gradual over the period of the generating plant’s lifecycle.

However, movements between different points in the scale could occur as step changes,; i.e. the annual load factor of a mid-merit CCGT could be considerably different to a low-merit CCGT. The timing of movements in the merit order position will depend upon the level of generation investment across the system,; i.e. investment in both the same and different technology classes,; and will be outside the control of a given generator.

## Commissioning

### *Description*

10.11 Commissioning generation plant will have no historic data to feed into the ALF calculation. The Proposer has made provisions for commissioning plant under the ALF approach. Such plant will be provided with a generic annual load factor that is representative of its type of generation.

### *Concern*

10.12 The trend over recent years suggests that commissioning new plant rarely goes smoothly. The Workgroup should considered whether an annual load factor that is representative of “proven” plant (or proven technologies, as further advancements are made) is an appropriate proxy for new plant (or new technologies) in the early days of generation.

## Upgrade / conversion

### *Description*

10.13 The upgrading (e.g. installation of new, more efficient equipment on an existing plant) and converting (e.g. change of fuel mix with modifications to existing plant infrastructure) of generating plant may lead generators to temporarily reduce their load factor (e.g. unit by unit modification) or close plant whilst work is completed.

### *Concern*

10.14 Short-term, one-off plant (or unit) closures may not be effectively captured by the ALF approach. If the reduction in generation occurs over multiple charging years, then the effect on ALF could be expected to average out. This is due to the calculation lagging behind, meaning the generator is expected to be assigned an ALF greater than the output when the generating plant first reduces load / switches off, then be assigned an ALF lower than the output for a period following the completion of the work.

10.15 An anomaly occurs where the work is completed over the course of a single charging year. In this situation, the charging year in which the generator contributes less to the exacerbation of transmission constraints is removed from the ALF calculation (i.e. via the removal of the extreme data points over the five year ALF period). This is a similar situation to a single charging year fuel switching (highlighted above).

10.16 However, an additional question for consideration is whether the generating plant can be considered to be the same technology following the upgrade or conversion. For example, does the plant move from being a low-merit generator to a mid-merit generator? Will the plant be expected to operate in the same manner as it did previously, i.e. is the five year historic data for the plant still relevant, or should it be treated similar to a newly commissioning plant?

## Replanting

### *Description*

10.17 Replanting could be considered to be a more substantive change to generating plant than an upgrade or conversion. It may involve the installation of a new technology as a replacement to the old plant. As a result it may also involve a significant change to the generator's connection agreement and a possible need to re-issue TEC to the new station.

#### *Concern*

10.18 Presumably, regardless of whether the generator continued to hold TEC (or not) from the point that the old equipment is decommissioned, through to the point that the new equipment is commissioned, the resulting plant would be treated as a newly commissioned plant.

### **Policy changes**

#### LCPD / IED Running Hours

##### *Description*

10.19 Environmental legislation, such as the LCPD and IED, may accelerate a generating plant's lifecycle due to the imposition of a restriction on running hours over a number of years. Whilst the LCPD and IED arrangements do not change a given generator's position in the merit order (i.e. it does not have an effect on the efficiency of the plant), it may cause the generator to operate differently. The generator's decision will depend upon a number of factors, including market conditions, maintenance requirements, regulatory outlook, etc.

10.20 For example, a generator may wish to use its legislatively limited running hours when it is able to capture higher market prices, such as in the winter peak. In contrast, a generator may decide to utilise their hours over a shorter period of time in order to avoid maintenance costs.

#### *Concern*

10.21 The key issue is where a generator feels compelled to make a step-change in their behaviour. As with the lifecycle scenario, this change is likely to be unidirectional, therefore the effect of the ALF approach on the generators TNUoS charge will not average out over a number of years.

### **Other**

#### Catastrophic plant failure

##### *Description*

10.22 In this scenario, a generator may have a significant failure of equipment that may take all, or a proportion, of its plant offline. For example, a generator permanently loses one of its two units due to a fire.

#### *Concern*

10.23 As with previous scenarios above, the generator could shift from a high annual load factor across both units (e.g. 75% across plant) to a high annual load factor across one unit (e.g. 37.5% across plant). Presumably, transmission TNUoS charging (and the annual load factor profiling) for the damaged unit would continue until such time that as the associated TEC can be released or the ALF approach averages out the step change (whichever occurs first).

## Mothballing of plant

### *Description*

10.24 Mothballed generating plant will be taken offline semi-permanently, although maintained to ensure it is still capable of being brought back to service. It is likely that the plant will be kept in a condition that means it cannot be brought back to service at short notice. The owner of the plant may continue to hold TEC throughout the period that the generating plant is mothballed, although the introduction of Connect and Manage may allow the generator the option of releasing TEC and reapplying when market conditions are more favourable.

### *Concern*

10.25 Would it be possible for a generating plant to be mothballed for a period of time, continue to pay transmission TNUoS charges for the TEC held, but then return for a winter with a (relatively) high annual load factor for which it pays a substantially reduced transmission TNUoS charge? How would such generating plant be treated if it were to relinquish its TEC and then reapply for it at a later date (effectively “re”-commissioning)?

10.26 How would infrequently run OCGT be charged TNUoS under CMP213? In a scenario with high-wind deployment and an (EMR) capacity mechanism, such generating plant may sit unused for long periods of time, but have occasional winters with high usage (for a short period of the charging year).

## Annex 11 – Comparison of Tariff Volatility

11.1 To assess the potential impact that the CMP213 Original proposal may have on volatility of future TNUoS charges and compare with the potential impact of volatility under the current methodology, generation tariffs were calculated using both the existing and the Original proposal TNUoS charging methodologies. The analysis concentrates on two areas: analysis of historical charging years: 2009/10 to 2012/13 and future charging years: 2013/14 and 2015/16.

### 1. Historical year's analysis

11.2 Data starting from charging year 2009/10 was chosen because this was the first year that local transmission tariffs were introduced to the TNUoS charging methodology. Input assumptions were unchanged from the values used in the final transport and tariff models for those years.

11.3 Figures A11.1 and A11.2 below show illustrative TNUoS tariffs derived using the original proposal methodology for a conventional generator with 70% annual load factor and an intermittent generator with 30% annual load factor respectively. Good correlation can be seen in most years with some deviation in charging year 2012/13. This effect is caused by a reduction of 500 MW of TEC in zone 7 which resulted in the re-allocation of some circuits from the Year Round to the Peak Security background. This effect is not seen by the intermittent generator, which is not exposed to the Peak Security element of the TNUoS tariff with the Original proposal.

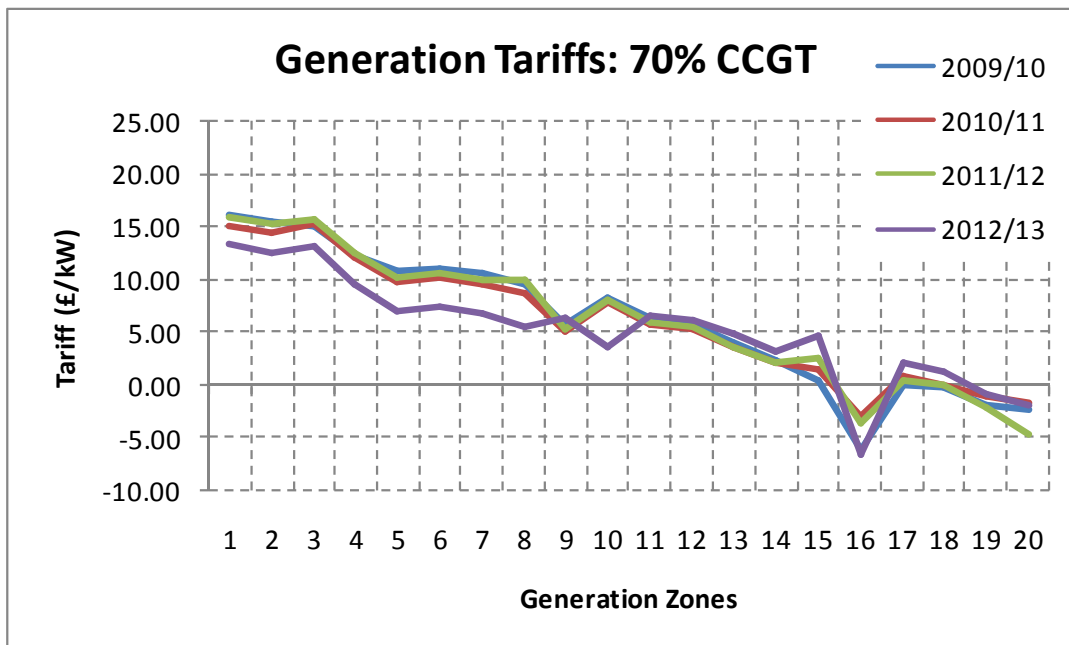
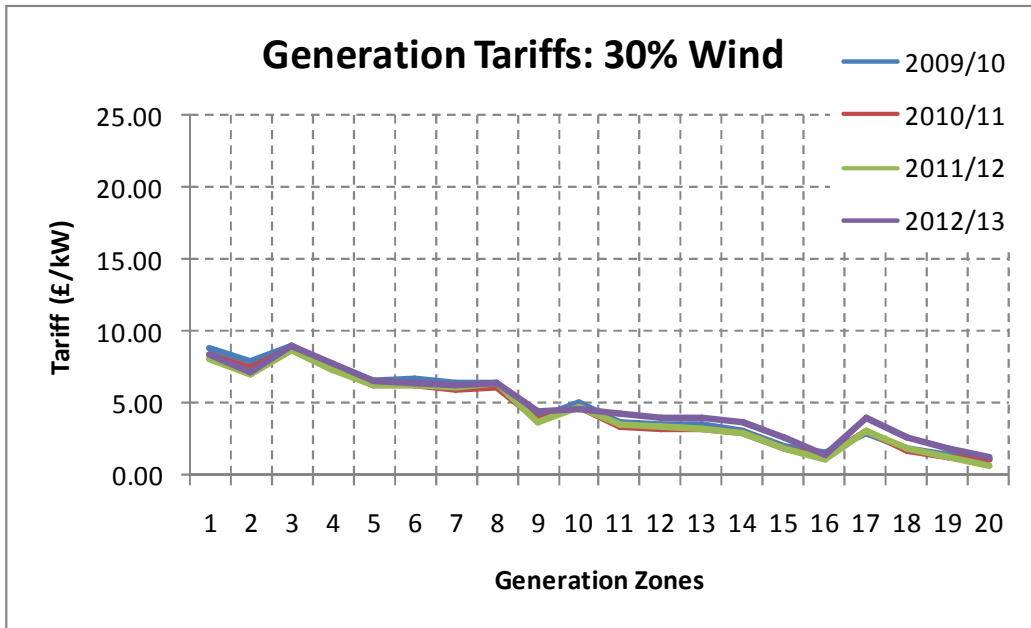


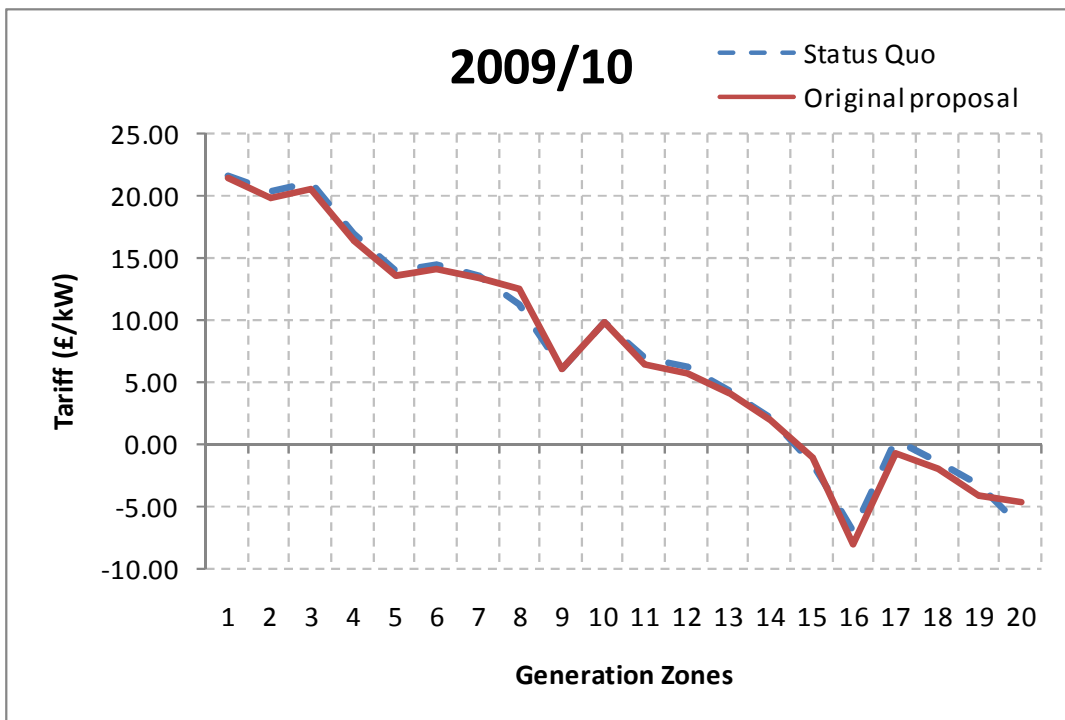
Figure A11.1 - Original proposal tariffs: Conventional Generation (70% Annual Load Factor)





**Figure A11.2 - Original proposal tariffs: Intermittent Generation (30% Annual Load Factor)**

11.4 Figures A11.3 to A11.6 show the existing methodology (i.e. Status Quo) and the Original proposal generation tariffs where both (Year Round and Peak Security) elements have been combined to aid comparison.



**Figure A11.3 - Status Quo and Original proposal 2009/10 tariffs**

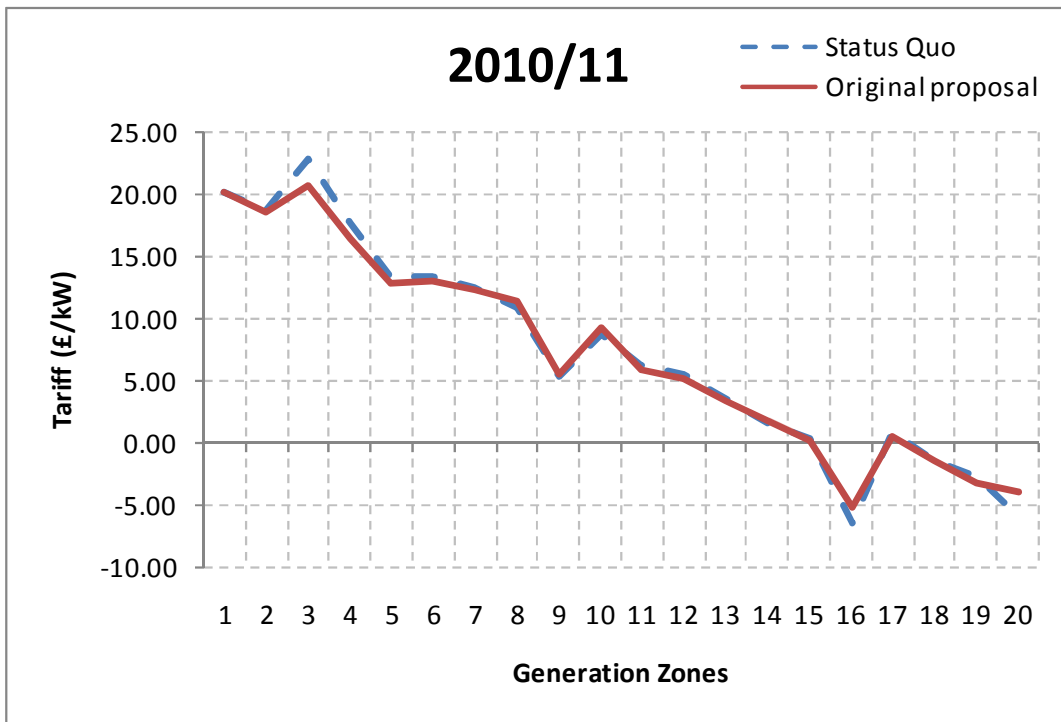


Figure A11.4 - Status Quo and Original proposal 2010/11 tariffs

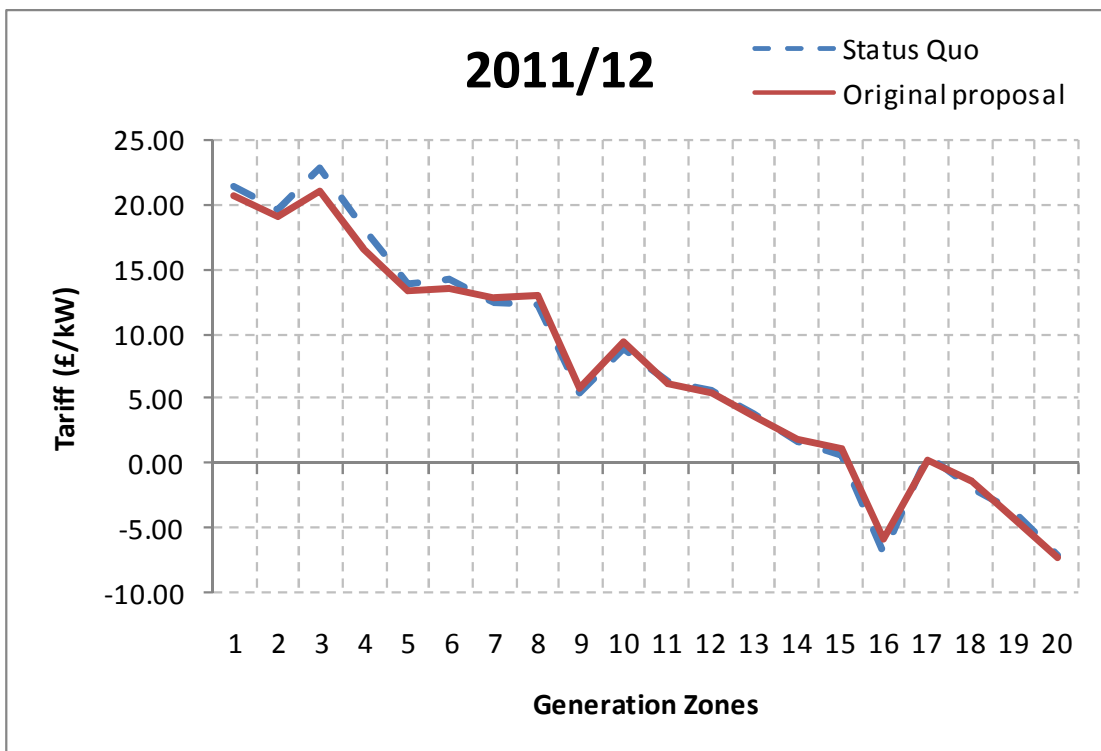


Figure A11.5 - Status Quo and Original proposal 2011/12 tariffs

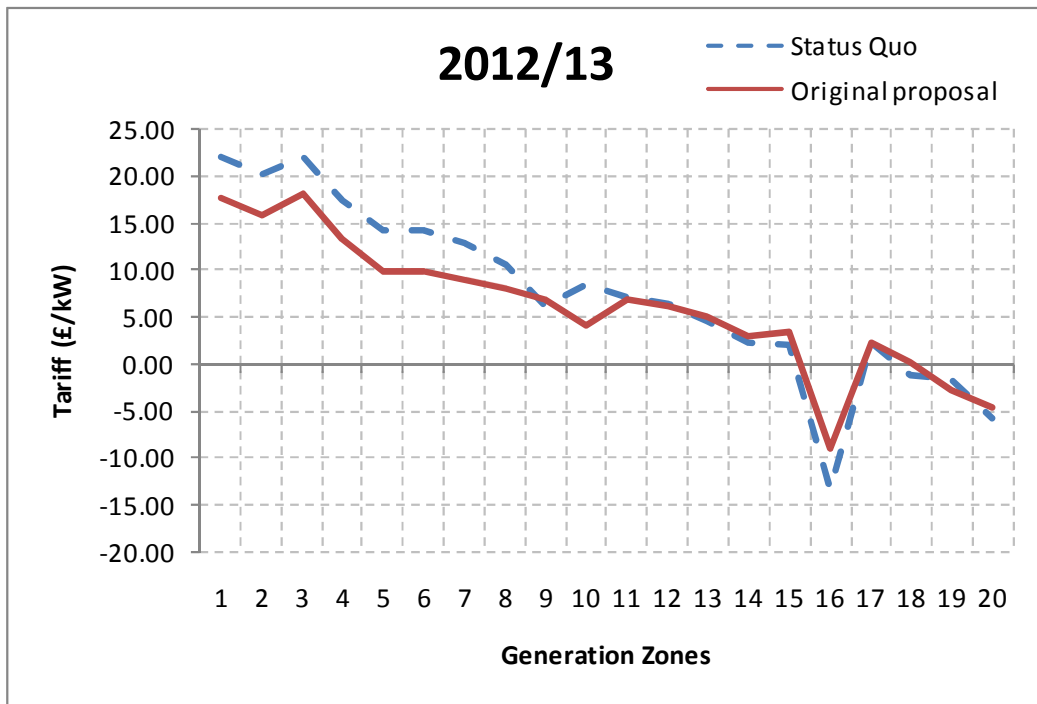


Figure A11.6 - Status Quo and Original proposal 2012/13 tariffs

11.5 Figures A11.7 through A11.10 illustrate the year on year differentials in generation tariffs for existing methodology (i.e. Status Quo) and the Original proposal.

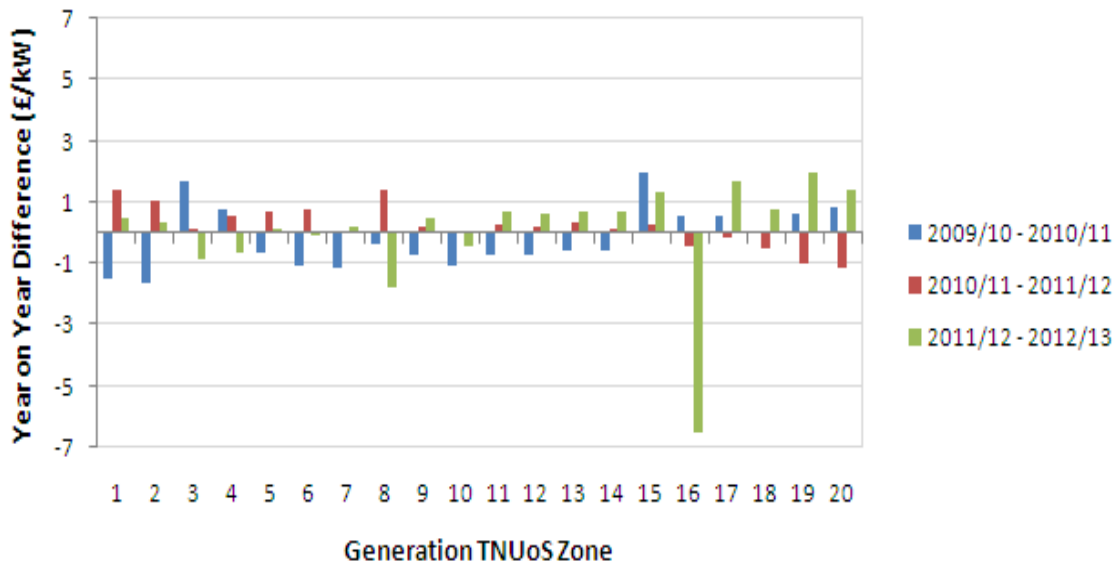
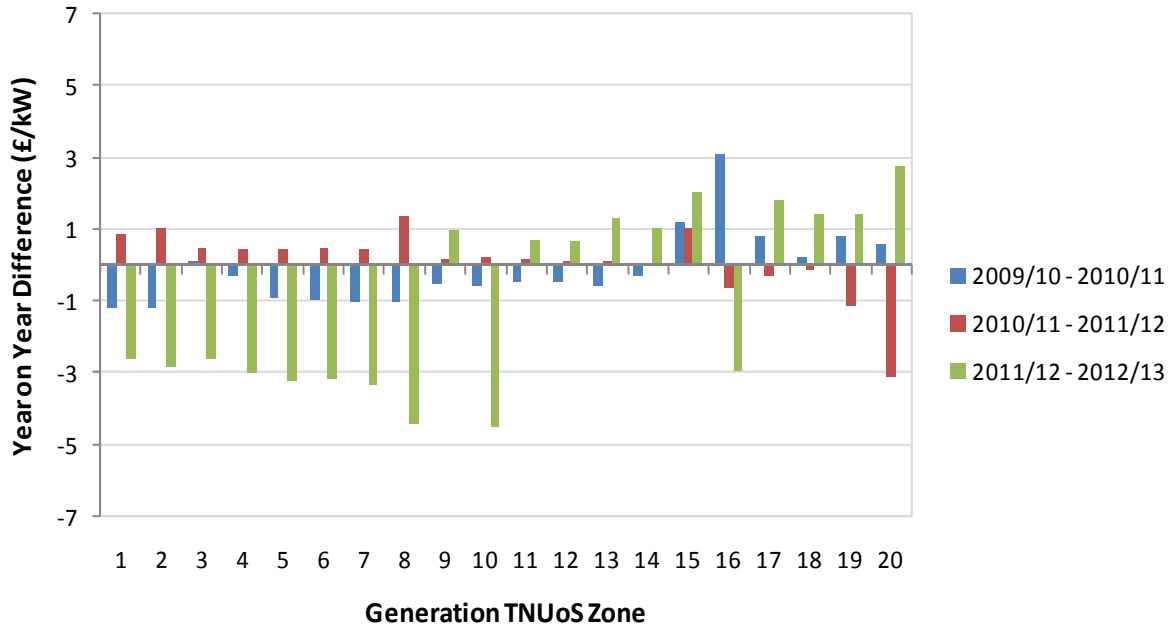
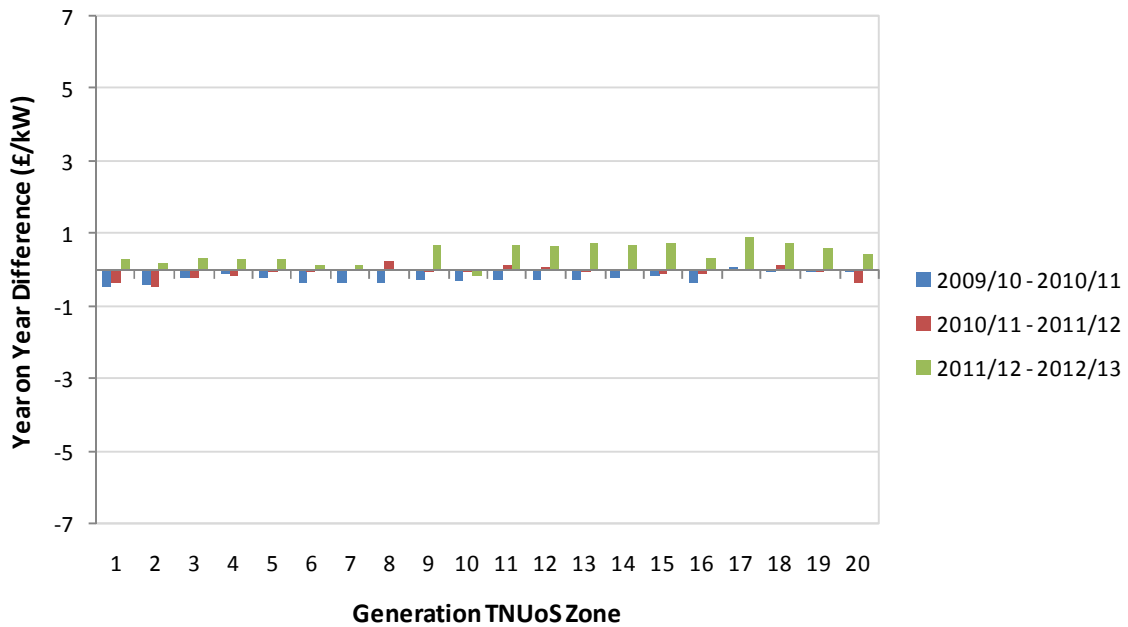


Figure A11.7 - Status Quo Year on Year Tariff Differentials



**Figure A11.8 – Original proposal Year on Year Tariff Differentials (70% CCGT)**



**Figure A11.9 - Original proposal Year on Year Tariff Differentials (30% Wind)**

## 2. Future year's analysis

11.6 National Grid's Gone Green, Slow Progression and Accelerated Growth generation scenarios were chosen as the main source of generation and demand data. Charging years 2013/14 and 2015/16 were chosen as they were deemed to be a good representation of the future in the short term.

11.7 To understand the effect of changes in the generation background, the following assumptions were made across all models to ensure consistency of analysis:

- a) Charging year 2011/12 values for the total transmission owner's allowed revenue (£m 1,724.28), local circuit, substation and offshore local asset charge revenues were kept constant;
- b) National Grid's 2011 Seven Year Statement<sup>34</sup> transmission network reinforcements were included in this work with the exception of the Western HVDC link in charging year 2015/16;
- c) The expansion constant and circuit length expansion factors were kept unchanged as per the values in the 2011/12 period shown in Table A11.1;

<b>Expansion Constant (£/MWkm)</b>	<b>11.142856</b>
------------------------------------	------------------

<b>Expansion factors</b>	<b>NGC</b>	<b>SPT</b>	<b>SHETL</b>
<b>400kV cable factor</b>	22.390	22.390	22.390
<b>275kV cable factor</b>	22.394	22.394	22.394
<b>132kV cable factor</b>	30.220	30.220	27.790
<b>400kV overhead line factor</b>	1.000	1.000	1.000
<b>275kV overhead line factor</b>	1.137	1.137	1.137
<b>132kV overhead line factor</b>	2.796	2.796	2.238

**Table A11.1 - 2011/12 Expansion Constant and Factors**

- d) Generation annual load factors (ALF) for use in the Original proposal final tariff calculation (charging years 2013/14 and 2015/16) were obtained as follows:

Using the Electricity Scenario Illustrator (ELSI) model, generation annual load factors were obtained for charging years 2011/12, 2013/14 and 2015/16 for each specific generation technology across all three generation scenarios. These load factors were then grouped by generation plant type in order to obtain average load factors across the country and percentages of increase/decrease were then

<sup>34</sup> [National Grid: 2011 National Electricity Transmission System \(NETS\) Seven Year Statement](#)

derived between charging years: 2011/12 - 2013/14 and 2013/14 – 2015/16.

As no major increases or decreases were observed on intermittent generation load factors, it was decided that charging year 2011/12 historic figures were to be maintained in future charging years for purpose of final tariff calculations used in this Annex.

For conventional plant the resulting percentages from the above exercise were then used as a proxy for increasing/decreasing the original charging year 2011/12 historic load factors to bring these up to their correspondent charging year value; and

- e) As a minimum of 5 charging years were needed to calculate the generation Annual Load Factor as per the Original proposal, the average load factors between 2011/12 - 2013/14 and 2013/14 - 2015/16 were used for charging years 2012/14 and 2014/15 accordingly.

11.8 For the purpose of this analysis TNUoS tariffs differentials between charging year 2011/12 – 2013/14 and 2013/14 and 2015/12 for intermittent generation with 30% annual load factors and conventional generation with 40% and 70% annual load factors were plotted against tariff differentials for the current methodology. These differentials are shown in figures 10 and 15 using Gone Green, Slow Progression and Accelerated Growth scenarios. It can be observed that the Original proposal does not appear to increase volatility. This effect was attributed to the use of the generation ALF approach.

11.9 For intermittent generation, the differential remained in the range between +1 and -1 £/kW for all 20 generation TNUoS charging zones. For conventional generation of similar annual load factor the differential spanned a slightly higher range due to its exposure to the Peak Security background introduced with the Original proposal.

11.10 In Figure A11.10, under the existing methodology (i.e. Status Quo), the largest values of differential correspond to TNUoS charging zones 3, 8, 11 and 16. The value in TNUoS zone 3 is the result of commissioning the Beaulieu – Denny transmission circuits. An increase in generation causes the increase in the TNUoS zone 8 tariff, whilst a decrease in generation causes a reduction in the TNUoS zone 11 tariff. Additional generation in the north of the country reverses the change in power flows on London cables affecting Zone 16 - Central London.

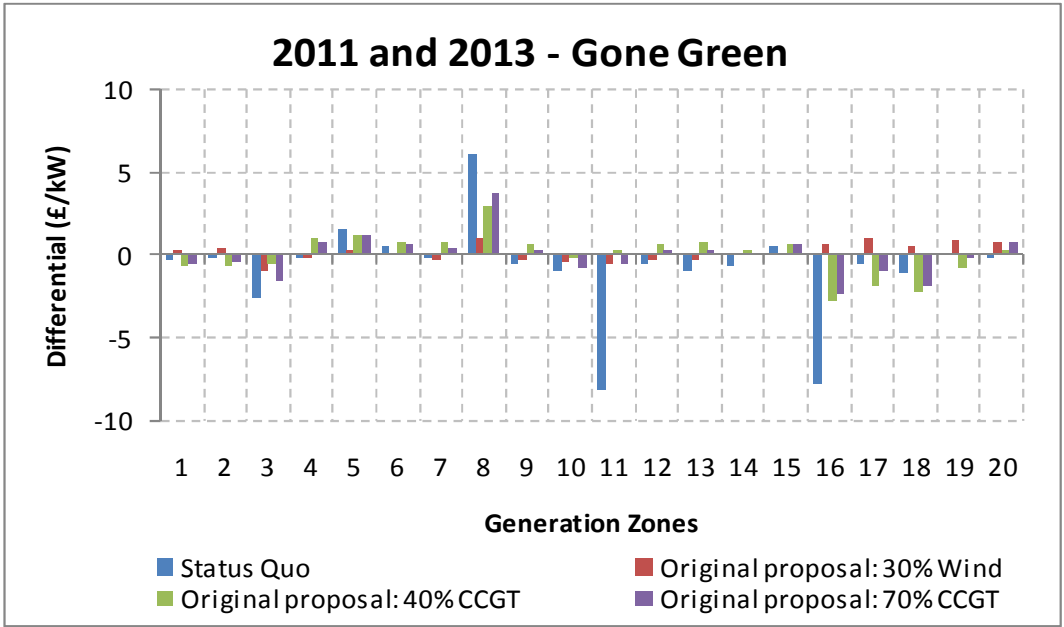


Figure A11.10 – Tariff Differentials between years 2011 and 2013

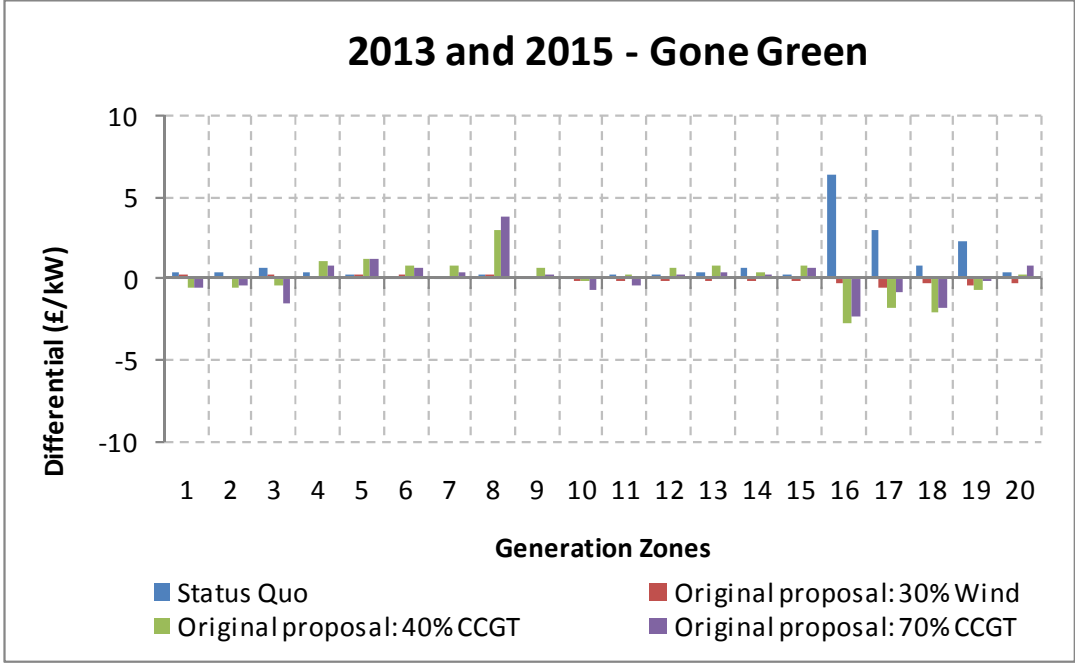
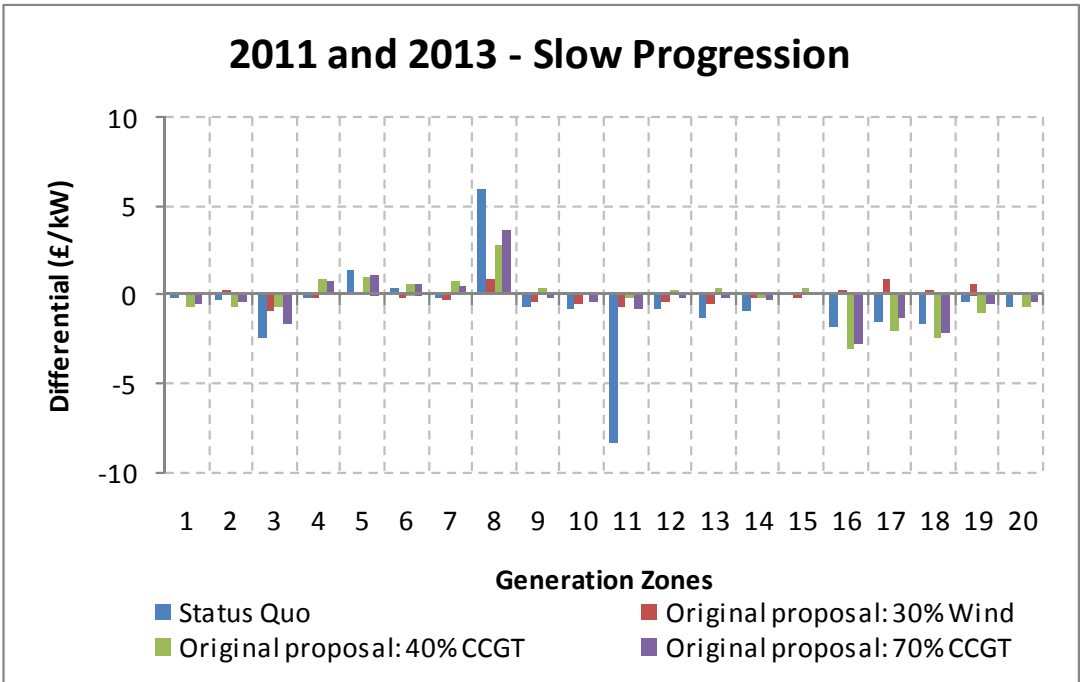
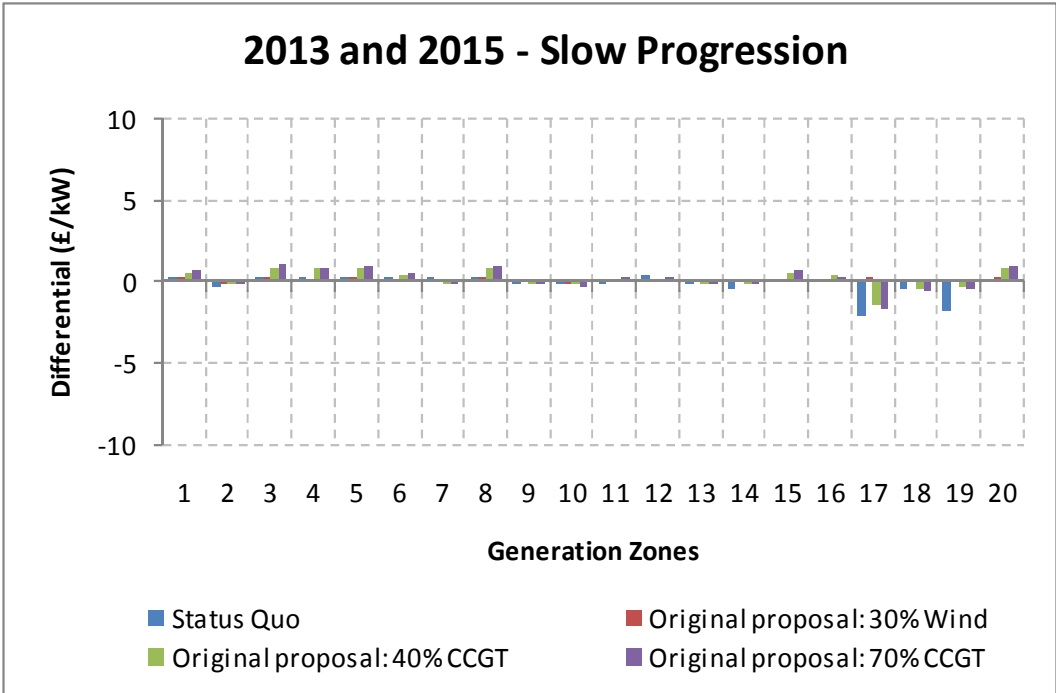


Figure A11.11 – Tariff Differentials between years 2013 and 2015

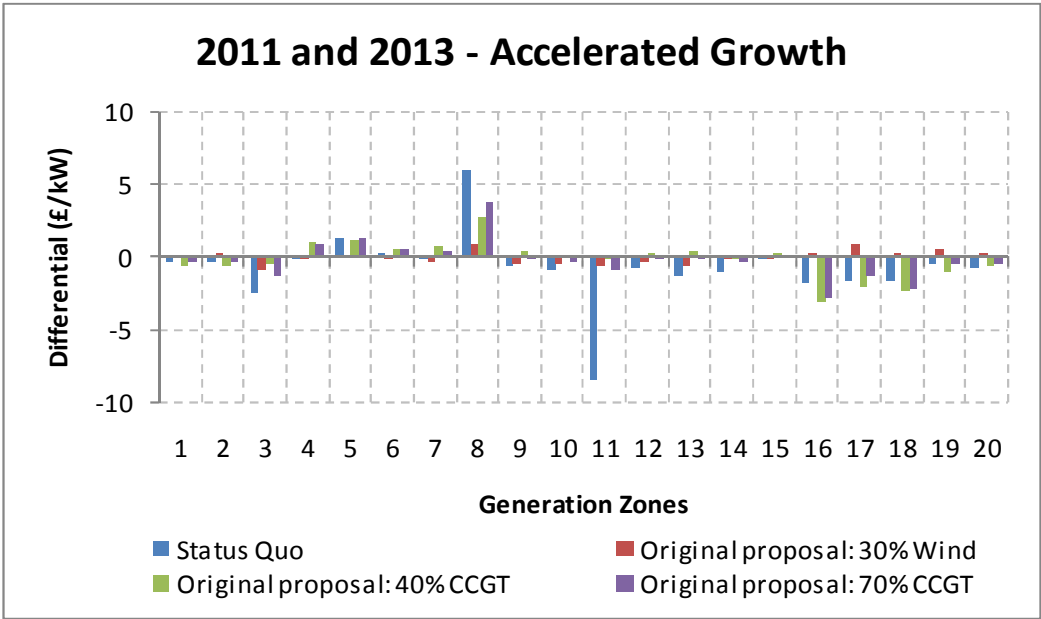


**Figure A11.12 – Tariff Differentials between years 2011 and 2013**

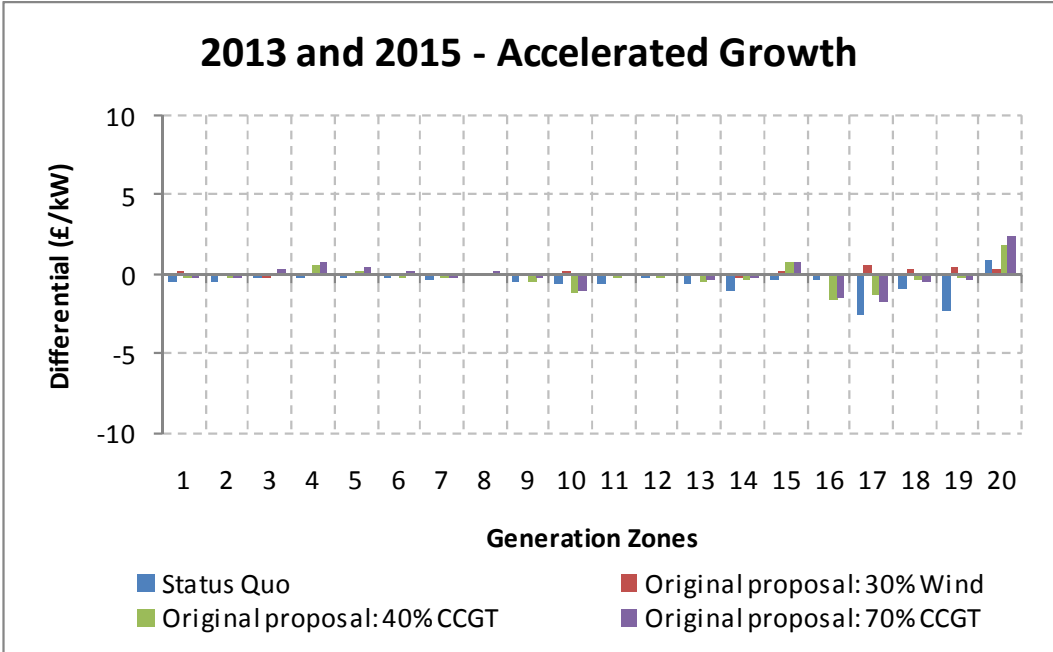


**Figure A11.13 – Tariff Differentials between years 2013 and 2015**





**Figure A11.14 – Tariff Differentials between years 2011 and 2013**



**Figure A11.15 – Tariff Differentials between years 2013 and 2015**

## Annex 12 – Annual Load Factor Under the Original

- 12.1 Under the CMP213 Original proposal, it is proposed to calculate an generation Annual Load Factor (ALF) in the TNUoS charging methodology calculation. Generation TNUoS charges are required to reflect the cost of transmission to allow generators to internalise the cost of using the transmission system when they are deciding where to site or when to close plant.
- 12.2 The Workgroup has some concerns over how closely generation ALF calculated on historic data, as per the Original proposal, would be to the actual annual load factor of a generator in a given TNUoS charging year. This was investigated, below.

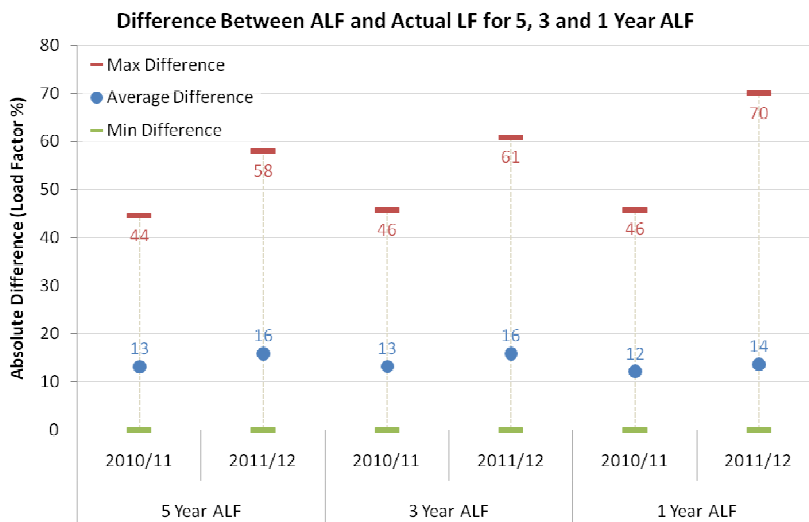
### Assumptions:

- Charging years 2010/11 and 2011/12 years were investigated;
- Actual generation annual load factor =  $\frac{\text{Metered Output of Generator (MWh)}}{\text{TEC (MW)} \times 8760 \text{ (h)}}$
- 5 Year generation ALF = previous 5 charging years actual generation annual load factor, remove largest and smallest values and average the remaining 3 charging years;
- 3 Year generation ALF = average of previous 3 charging years actual generation annual load factor; and
- 1 Year generation ALF = previous charging year actual generation annual load factor.

### Analysis of results

- 12.3 The results of the analysis are shown in Figures A12.1 to A12.12 below. From Figure A12.1 the following observations can be made:

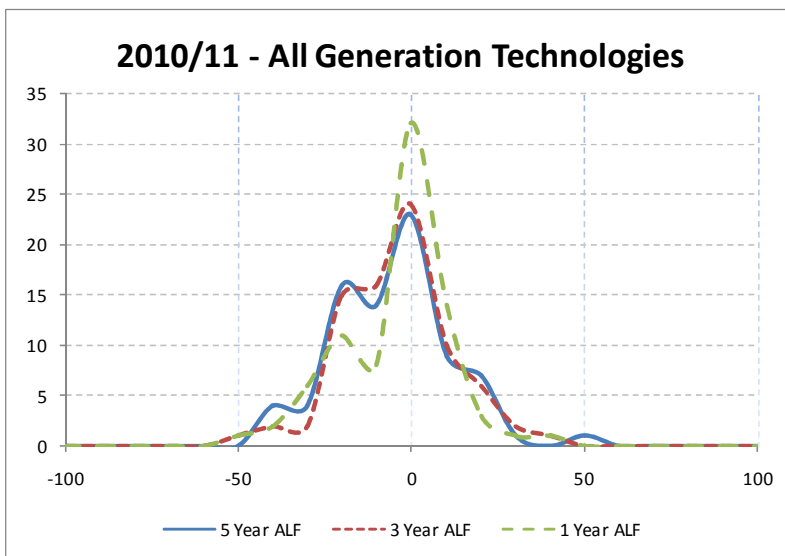
- Average of differences across generators are quite similar; and
- Charging year 2011/12 seems to show an increase in volatility for individual generation plant due to greater maximum difference between ALF and actual



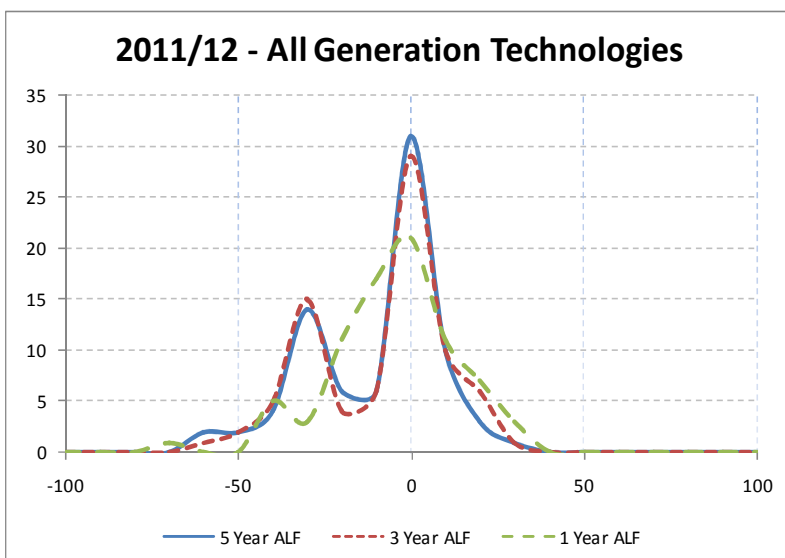
**Figure A12.1 – Differentials between Annual Load Factor and Actual Load Factor**

12.4 Figures A12.2 to A12.11 show distribution curves for all combined generation technologies and specific types. The total number of generation units sampled was 78 as specified in the table below.

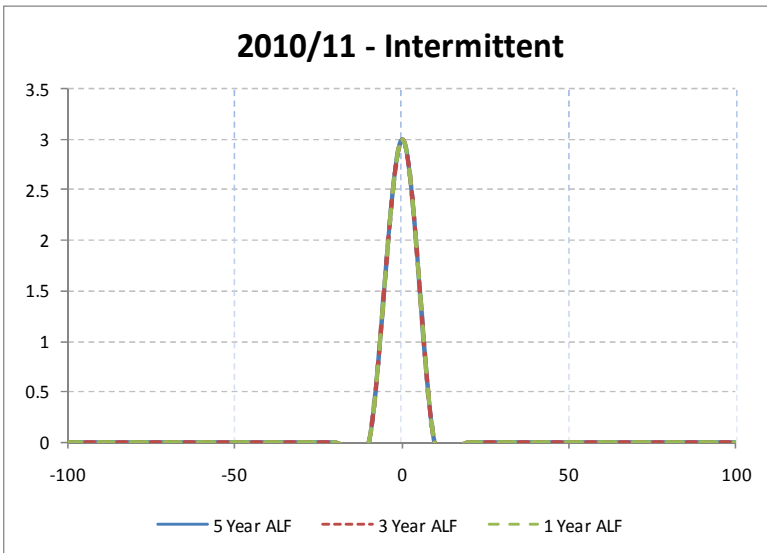
Generation technology	Sample size
Intermittent	3
Nuclear and CCS	11
Hydro	6
Other conventional	58
<b>Total</b>	<b>78</b>



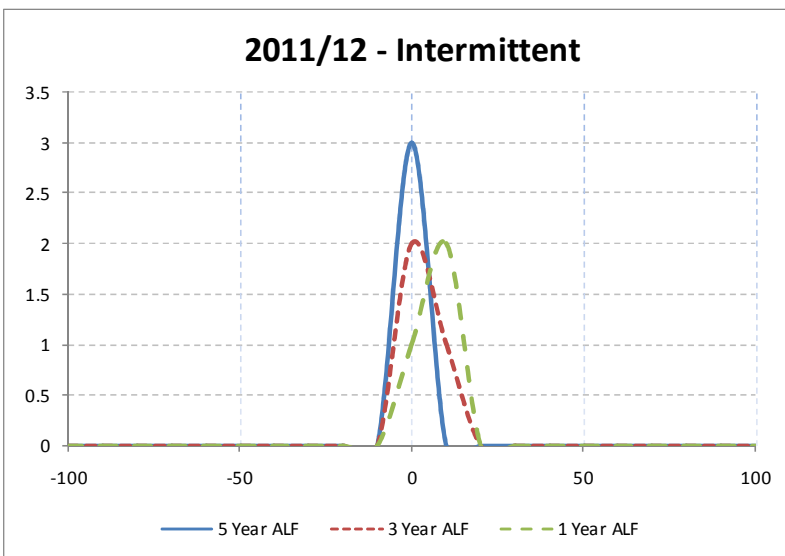
**Figure A12.2 - Distribution curves for all types of generation technology**



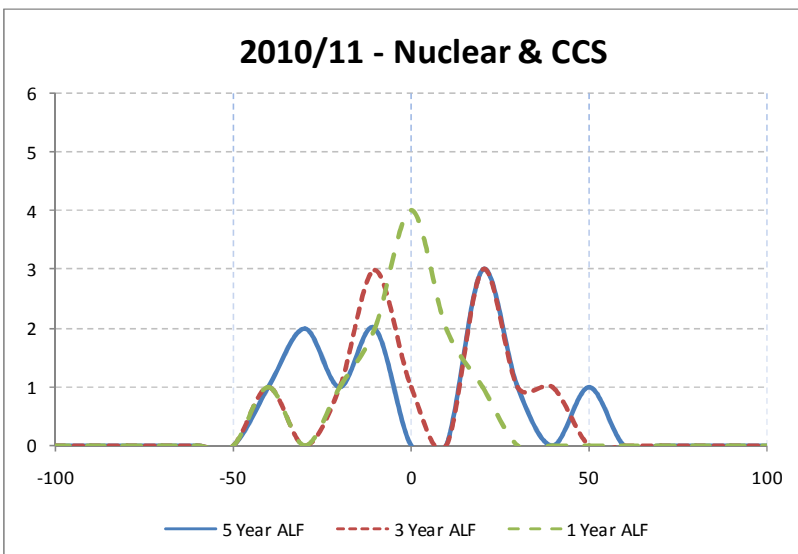
**Figure A12.3 - Distribution curves for all types of generation technology**



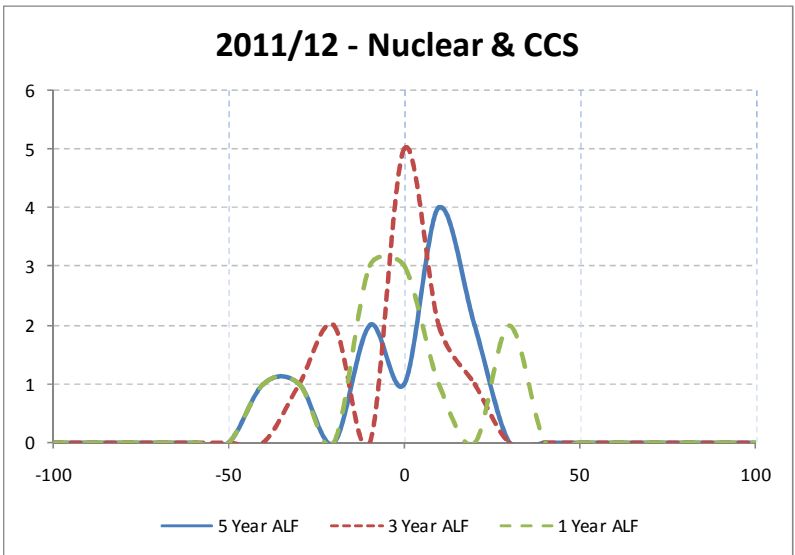
**Figure A12.4 – 2010/11 Distribution curves for intermittent technology**



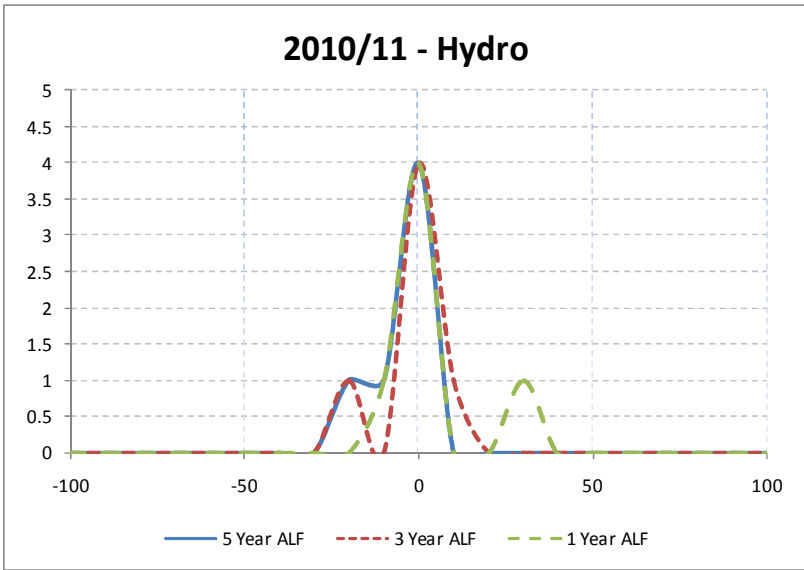
**Figure A12.5 – 2011/12 Distribution curves for Intermittent technology**



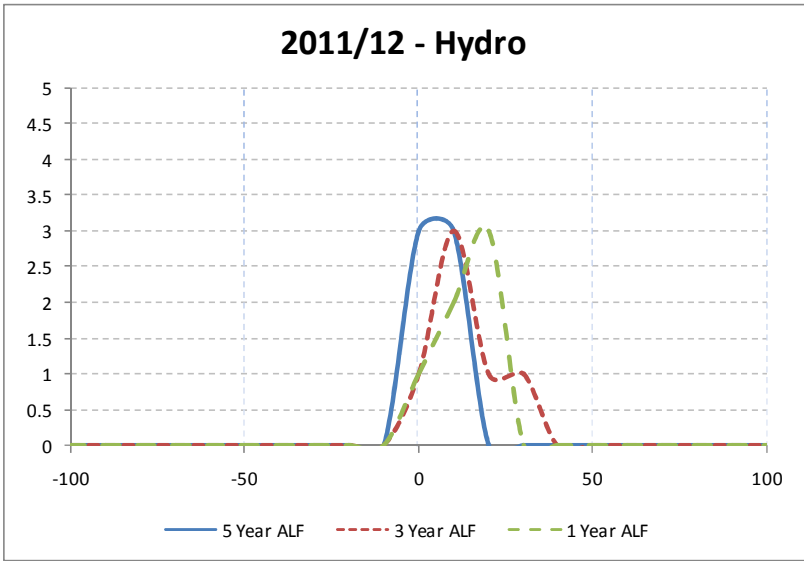
**Figure A12.6 – 2010/11 Distribution curves for Nuclear and CCS technology**



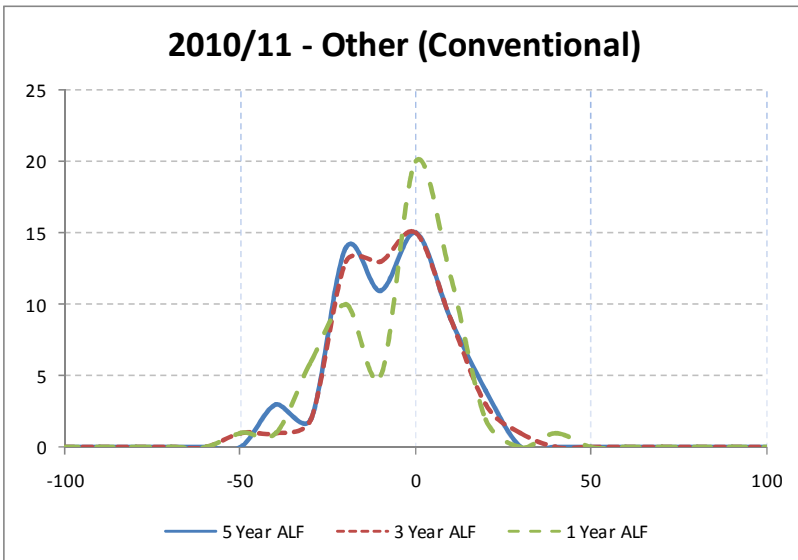
**Figure A12.7 – 2011/12 Distribution curve for Nuclear and CCS technology**



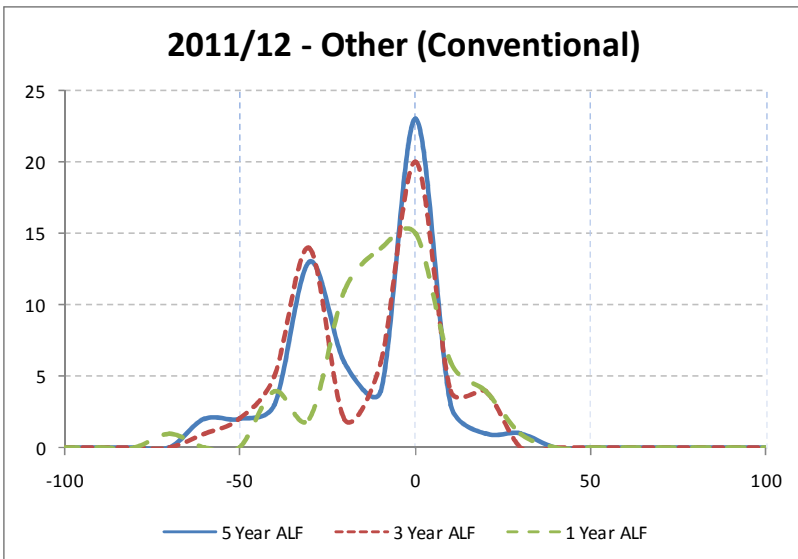
**Figure A12.8 – 2010/11 Distribution curves for Hydro generation**



**Figure A12.9 – 2011/12 Distribution curves for Hydro generation**



**Figure A12.10 – 2010/11 Distribution curves for other conventional plant**



**Figure A12.11 – 2011/12 Distribution curves for other conventional plant**



# Year-round System Congestion Costs - Key Drivers and Key Driving Conditions

A report to Centrica and RWE

Professor Furong Li  
Jiangtao Li  
Professor David Tolley

January 2013

## **Executive Summary**

### ***Project scope and approach***

Centrica and RWE have commissioned the University of Bath to undertake a review of two aspects of the proposals advanced in the CMP213 Working Group consultation of 7<sup>th</sup> December 2012. These relate to that part of the CMP213 proposals intended to improve the incremental cost signal in the ICRP methodology. Specifically, the University of Bath has been asked to address:

- The use of a generator annual load factor as a proxy for the causation of constraint costs; and
- The use of a dual background for devising the locational signal in TNUoS charges.

In order to address these points the University of Bath has undertaken a series of high-level studies based on a representation of the GB transmission system so as to test the basis for the CMP213 proposals. These studies focus on the key driving factors which determine year-round congestion costs. The studies attempt to answer three fundamental questions that underpin the network sharing concept.

- i) Is it appropriate to assume that load factors can be used to represent a generation technology?
- ii) Is it appropriate to assume a linear relationship between load factors and congestion costs, so that load factor can be used as a proxy for year-round congestion costs?
- iii) Can a dual background realistically reflect the congestion conditions and thus its costs throughout the year?

### ***Conclusions***

The University of Bath supports the industry's effort to enhance the TNUoS charging methodology such that it can recognise the impact of differing generation technologies on incremental transmission network cost/congestion cost, particularly in the light of the rising volume of intermittent renewable generation across the system. However, we have serious misgivings over the direction that 'network sharing' takes in the original CMP213 proposals. We believe the approach proposed could seriously compromise the objectives of project TransMIT which are to *"to facilitate the timely move to a low carbon energy sector whilst continuing to provide safe, secure, high quality network services at value for money to existing and future consumers"*.

#### ***i) Load factor analysis***



Our work demonstrates that a generator's load factor is not a fixed parameter, but a highly complex parameter that is shaped by network location, network characteristics (in terms of length, capacity, utilisation, congestion across each interconnected boundaries), characteristics of generation (such as generation mix, efficiency, controllability, cost curves and output variability), characteristics of demand (such as demand duration curves, and demand profiles), the direction and utilisation of interconnectors, as well as market fundamentals. This is an important result because CMP213 uses a fixed load factor assumption to differentiate generation technologies as a key initial input to deriving charges. These are borrowed from the SQSS and then used to allocate circuits as falling into 'year-round' or 'peak' categories.

Our study shows that for the same generation technology but with different efficiencies (price), location, and boundary congestion levels, generators will have very different load factors. Our example shows that an increase in boundary capacity leads to less congestion resulting in lower cost generation being able to transfer more power thus increasing its load factor, whilst the load factor of the more expensive generation reduces. In the simplified network chosen for the study, when the transmission transfer capacity was increased by 25%, the load factor of the cheaper generator increased from 60% to 65%, while the more expensive generator load factor fell from 12% to 5%. The consultation document also observed that as the penetration of intermittent generation increases, the output of conventional generation will change and evolve with it over time.

Annual load factor for a generation technology is a variable that is shaped by differing generator and demand parameters, and features of the transmission system. It is thus inappropriate to use the same load factor for a generation technology regardless of its locations, efficiencies and market behaviour.

*ii) The relationship between load factor and year-round congestion costs*

When investigating the possible relationships between year-round congestion cost and annual load factor, we have illustrated how a change in wind penetration level, transmission capacity and generation price characteristics might impact load factor and congestion costs. Our studies demonstrated that under different network, generation and demand conditions the relationship between congestion costs and load factor can vary significantly. The relationship most certainly can not be assumed to be linear.

**It is thus impossible to infer that by assuming linearity between load factor and constraint costs the charging methodology will be enhanced; unless account is also taken of other factors such as location, efficiency, market conditions, and critically, the network transfer capability.**

*iii) The dual background approach*

To examine the validity of introducing a dual background approach into charging as proposed by CMP213, we have developed the concept of a congestion duration curve that charts the variation in the magnitude of congestion costs throughout the

year. The objective has been to investigate how congestion cost varies in strength and duration, over time and between locations.

Our study is of a system that comprises a representation of the B6 and B15 boundaries; the two GB boundaries with the heaviest congestions. The congestion duration curve in Figure 1 below shows that congestion arises in varying degrees, over different time periods. Table 1 shows that congestion cost is not only linked to the magnitude of congestion, but critically to time, duration and location.

Part 1 of the curve indicates a period of extremely high congestion where costs are in excess of £44k per settlement period. Although of considerable magnitude this high level of cost is incurred for only 23 settlement periods out of a total of 17,520 in the year. The proportion of the total annual congestion cost in this period is thus relatively small (1.1%), and can for all practical purposes be ignored when approximating the year-round congestion cost.

Part 3 of the curve represents the largest share of the year-round congestion costs but still only accounts for 5,427 settlement periods or 31% of the year. The issue in relation to the CMP213 proposals is that in the original proposals the annual load factor is averaged over the course of the year and consequently its use as a proxy for congestion could severely underestimate the congestion costs over the critical congestion periods; and thus significantly dilute the efficacy of the economic signals.

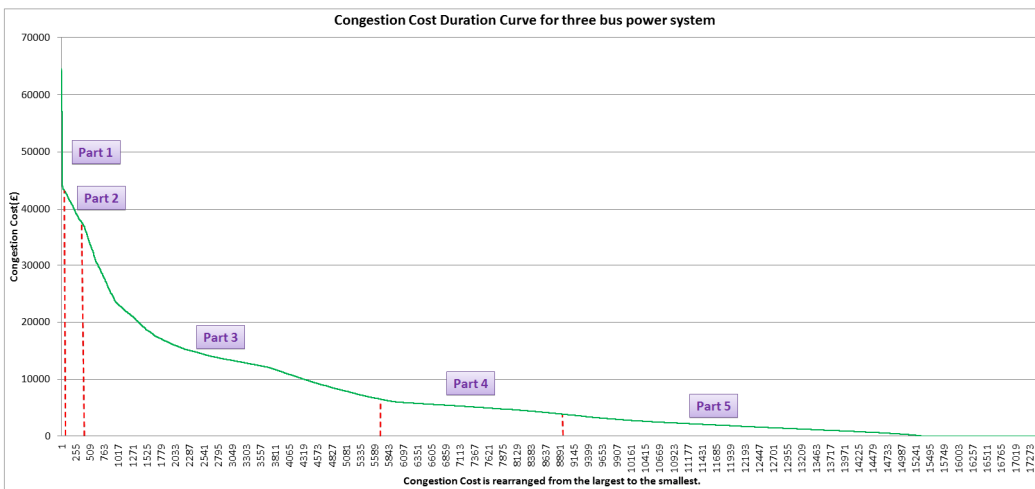


Figure 1: Congestion duration curve.

Table 1: Congestion cost between B6 and B15 for parts of congestion duration curve

	Number of settlement periods	B6 Congestion Cost £M	B15 Congestion Cost £M	Total Congestion Cost £M	Congestion share between different the 5 parts	Proportion of B6 in Total Congestion Cost	Proportion of B15 in Total Congestion Cost
Part 1	23	1.3	0	1,3	1.06%	100.00%	0.00%
Part	394	12.0	3.8	15.8	12.87%	75.75%	24.25%

2							
Part 3	5427	67.4	11.3	78.7	63.91%	85.63%	14.37%
Part 4	3042	4.8	10.7	15.5	12.57%	31.44%	68.56%
Part 5	8634	10.9	0.9	11.8	9.58%	92.71%	7.29%
Total	17520	96.5	26.6	123.1	100.0%	78.38%	21.62%

We have also investigated the most significant periods that contribute to the majority of year-round congestion costs, and how the congestion cost is shared between B6 and B15 boundaries. Our study shows that the periods covering parts 2, 3, and 4 of the congestion duration curve shown in Figure 1 account for 94% of system congestion. It is these periods that should be adopted as background scenarios for deriving the year-round congestion costs since they display both high magnitude and/or long duration.

The study also indicates that congestion costs not only vary over time and duration (different backgrounds), but also vary significantly between boundaries. The B6 boundary is responsible for over 80% of all system congestion, but this congestion does not occur with the same degree or at the same time across as across the B15 boundary. In fact the B6 and B15 boundaries are only congested simultaneously for 14% of the year. Furthermore congestion across B6, when it occurs is significantly higher than across B15. This suggests that congestion cost is sensitive not only to time and duration, but more significantly to the location of the boundary.

These differences of congestion in terms of magnitude, time and location are not reflected in the proposals for an improved ICRP. Employing load factor as a surrogate for the cause of congestion smears the consequence for one boundary across all boundaries and throughout the year. The use of annual load factors in a year-round scenario to reflect year-round congestion costs essentially assumes that all boundaries have the same level of congestion throughout the year. It cannot provide an appropriate economic message for reducing congestion, and it certainly will not reflect the costs of congestion in accordance with SLC 5.5b

## **Summary of Key Findings**

- Annual load factor of a generation technology is not a fixed parameter but a variable that changes with generation, network and market conditions. It is thus inappropriate to use it as an input for a generation technology regardless of its location, efficiencies and market behaviour.
- The relationship between load factor and congestion cost most certainly can not be assumed to be linear. Load factor is a measure of an average output of a generation technology over the year; whilst congestion cost is sensitive to time (backgrounds), duration elements and boundary locations. The relationship between load factor and congestion cost varies greatly with transmission transfer capabilities, demand profiles and generation mixes, efficiency, controllability and their locations in the system.
- It is not appropriate to infer that by assuming linearity between load factor and constraint costs the charging methodology will be enhanced; unless it is further amended to take account of other factors, such as location, efficiency, market conditions and critically, network transfer capability.
- Even for a simple representation of the GB transmission system it is necessary to recognise at least five different congestion periods that will reflect the incidence of year round congestion. Within each period there are considerable differences in the timing and sharing of network congestion costs between the two most heavily congested boundaries.
- The single “year-round” condition is flawed in that it does not reflect the difference in magnitude, duration and location of the congestion. Instead the scenario proposed will represent an extremely high congestion condition that lasts for a very limited duration, and contributes little towards overall system congestion costs.
- Employing load factor as a surrogate for the cause of congestion smears the consequence for one boundary across all boundaries and throughout the year, by assuming that all boundaries have the same level of congestion at all times in the year. It cannot provide the necessary economic message for reducing congestion, and it certainly will not reflect the costs of congestion as required by the Licence Conditions.
- Our view is that a consequence of adopting the current CMP 213 proposals for an improved ICRP methodology will be to increase congestion costs, which would be perverse given the objectives of project TransmiT . Our conclusion is that employing only two backgrounds would fail to create even the crudest representation of system performance and costs.

## **Recommendations**

- **Targeting TNUoS charges and credits in periods and locations where generator output contributes to, or relieves congestion would be an improvement to the existing ICRP methodology. However, this implies a time of use and congestion location feature in TNUoS charges rather than it being linked to generator annual load factors.**

- **A TNUoS methodology that related charges to times and boundaries where congestion was most severe would be a significant improvement to the existing methodology. This could be achieved by introducing a time of use element (congestion factor) to the existing peak security based TNUoS charges. The present year-round scenario would be expanded to become a number of scenarios that are directly linked to congestion times and boundaries.**
- **If multiple scenarios with their respective time periods and duration are too complicated, then the existing ICRP methodology should be retained on grounds of simplicity rather than diluting and distorting its pricing incentives. Creating a dual background would be a retrograde step in the reflection of costs, and the provision of useful economic signals for transmission and generation investment.**

## 1. Introduction and Background

### 1.1. Study remit

Centrica and RWE have commissioned the University of Bath to undertake a critique of two aspects of the proposals advanced in the CMP213 Working Group consultation of 7<sup>th</sup> December 2012. These relate to that part of the CMP213 proposals intended to improve the incremental cost signal in the ICRP methodology. Specifically The University of Bath has been asked to address:

- The use of a generator annual load factor as a proxy for the causation of constraint costs; and
- The use of a dual background for devising the locational signal in TNUoS charges.

It has also been suggested that the conclusions should opine on whether a single background would better meet the required charging objectives, instead of the dual background proposed for the Improved ICRP proposals.

### 1.2. Charging principles

When assessing the merits of any future charging methodology it is useful to consider the relevant licence conditions. Standard Licence Condition SLC.5.2 requires that NGET “*make such modifications of the use of system charging methodology as may be requisite for the purpose of better achieving the relevant objectives*”. The relevant objectives are described in SLC 5.5 and oblige NGET to ensure:

- (a) *that compliance with the use of system charging methodology facilitates effective competition in the generation and supply of electricity and (so far as is consistent therewith) facilitates competition in the sale, distribution and purchase of electricity;*
- (b) *that compliance with the use of system charging methodology results in charges which reflect, as far as is reasonably practicable, the costs incurred by transmission licensees in their transmission businesses and which are compatible with standard condition C26 (Requirements of a connect and manage connection); and*
- (c) *that, so far as is consistent with sub-paragraphs (a) and (b), the use of system charging methodology, as far as is reasonably practicable, properly takes account of the developments in transmission licensees' transmission businesses*

NGET recovers its costs through TNUoS and BSUoS charges. TNUoS charges recover the revenues permitted under NGET’s price control set by the Authority. TNUoS is currently based on the extant ICRP methodology that produces an economic signal for the location of generation and demand.

BSUoS recovers the costs of securing the system. It mainly comprises the costs of providing reserve in its various forms and the costs of resolving system constraints. The costs recovered by BSUoS have proved extremely volatile and difficult to predict, especially in the short term. BSUoS is levied equally on both

generation and supply (in respect of demand) on an ex-post half-hourly basis. Socialising these costs between all parties is a political rather than an economic decision but it sits uneasily with the idea of incorporating constraint cost considerations into TNUoS charges.

### 1.3. Transmission congestion

The implementation of BETTA on 1<sup>st</sup> April 2005 increased sharply the costs of resolving constraints as is apparent from the following table:

Table 2: Change in constraint costs following BETTA implementation

£ million	2004/05	2005/06	2006/07
England & Wales	15.1	19.6	20.3
Cheviot (B6) boundary	0	31.6	20.3
Within Scotland	0	28.5	43.9
GB Total	15.1	79.7	93.2

During 2008 NGET provided Ofgem with its forecast of total system constraint costs in 2008/09 and 2009/10. This forecast suggested that costs would increase in these years to £238 million and £262 million respectively, of which around £210 million would be due to actions in the more northern parts of the GB system in each year.

Faced with this escalation Ofgem published (17<sup>th</sup> February 2009) an open letter expressing concern at NGET's substantially increasing forecast. The letter also noted the constraint costs that had been incurred since BETTA implementation. The data appears to be on a slightly different basis to that in the previous table but shows the same pattern in the two years post BETTA.

Table 3: Trends in constraint costs taken from Ofgem 17 February 2009 letter

£ million	2005/06	2006/07	2007/08
Arising from Scottish actions	70.0	80.0	42.0
Total GB constraint costs	84.0	108.0	70.0

The letter suggested a number of actions that NGET could take. These included:

- i Actions to reduce the volume of constraints
- ii Reductions in the price paid to resolve constraints
- iii Reviewing whether the charging mechanisms are "*equitable and appropriate*"

In view of increasing intermittent renewable generation, NGET raised a modification to the Security and Quality of Supply Standards (SQSS) that aimed to differentiate between conventional and intermittent generation when determining the system capacity needed to securely transfer power between zones. GSR009 proposed a "dual criteria" approach when planning reinforcement of the transmission network that would take account of both demand security and economic efficiency. The proposal was approved by Ofgem on 1<sup>st</sup> November 2011.

#### **1.4. Significant Code Review**

On 7<sup>th</sup> July 2011 the Authority announced that it would conduct a Significant Code Review under SLC 10 of the transmission licence with the objective of implementing the conclusions from its Project TransmiT. Project TransmiT was an open review of the transmission charging and connection arrangements in order to facilitate a smooth transition to a low carbon energy sector. The results of the SCR were published on the 4<sup>th</sup> May 2012. These noted (in paragraph 5.8) that:

*“The use of a load flow model is robust if the incremental flows identified closely correlate with the resultant costs. The impact of this would be to promote more efficient decision making by parties... If, however, the relationship between costs and charges is more complex, then the retention of the existing ICRP methodology could have the effect of blunting the signals relating to the need for incremental requirements ... and therefore the underlying costs of providing transmission capacity for different users at different locations”*

In the conclusions to the SCR Ofgem went on to direct (paragraph 5.9) that NGET:

*“Develop an improved form of ICRP that recognises the dual background approach of the recently modified NETS SQSS”.*

Ofgem’s direction to NGET has introduced an unfortunate confusion that is repeated in the CMP213 proposals. GSR009 requires a “dual criteria” approach when assessing the transmission system capacity that should be provided. The first criterion, the ***demand security criterion***, requires the provision of sufficient capacity such that peak demands can be met without intermittent generation. This effectively carried forward the previous basis for the NETS SQSS. The second criterion, an ***economy criterion***, requires that sufficient transmission system capacity be provided to accommodate all types of generation in order to meet varying levels of demand efficiently. This part of the approach uses a generic Cost Benefit Analysis (CBA) to create an economically efficient balance between the costs of constraints, and the costs of transmission reinforcements.

The intention behind this “dual criteria” approach is clear. The deterministic peak load flow scenario would be overlaid by an economic assessment as to whether it would be more efficient to constrain intermittent generation off and other generation on, or provide additional transmission capacity in the event that the intermittent generation produced output at times of system peak. The Ofgem direction corrupts this starting point by requiring that NGET’s modification should be based on a “dual background”. CMP213 carries forward this confusion by promoting a peak and year round background as the basis for two separate charges, together with the allocation of circuits to one background or the other.

#### **1.5. CMP213 objectives**

Accordingly on 20<sup>th</sup> June 2012 NGET raised CMP213 with the objectives of:

- i Recognising the network capacity sharing by generators in the Investment Cost Related Pricing (ICRP) TNUoS charge calculation;



- ii Introducing an approach for including HVDC links that parallel the onshore AC network into the charging methodology;
- iii Introducing an approach for including Island links in the charging methodology.

This report addresses two of the issues relevant to the first of the stated objectives for the original CMP213 proposal, and which are raised in the CUSC Modification Working Group consultation of 7<sup>th</sup> December 2012. These are:

- i The use of generator load factor as a proxy for determining the costs of constraints on the transmission system; and
- ii The use of a dual as opposed to single background as the basis for deriving TNUoS charges for generation.

## **2 Load Factor as a proxy for determining constraint costs**

### ***2.1 Introducing the study***

The CMP213 proposal adopts the approach that generator load factor can be used as a proxy for the incidence of constraint costs that would accompany an incremental MW at each node in a charging zone. The assumption is based on the empirical results from the use of the ELSI model which simulates the impact of various scenarios that could accompany future planning backgrounds for the system. The results from these studies have led to the conclusion that the relationship between congestion cost and generator load factor is linear. The methodology proposed for an improved ICRP (IIRCP) therefore asserts that generators with high load factors will contribute more to system congestion regardless of their location and time of generation; and thus should pay a greater proportion of use of system charges.

However, as the Consultation document notes, generator annual load factor is not a cost driver but merely the symptom of the relative economics of each generator *“including its availability, fuel cost, efficiency, CO<sub>2</sub> prices, and subsidies such as ROCs”* (consultation document paragraph 4.21). Furthermore the apparent empirical relationship becomes even less linear where there is a predominance of intermittent generation, which is precisely where the ICRP methodology needs to be most effective if it is to replace the current methodology.

Consequently our inclination is to share much of the disquiet that has been raised by many of the working group at this suggestion. The purpose of the study that is described below is to investigate whether the relationship between congestion cost and load factor is indeed linear.

### ***2.2 The study framework***

In this study three factors are chosen for the purpose of investigating their impact on the year-round congestion costs and generator load factor. These were chosen on the basis that they are the factors that are mostly likely to change in the near and medium term. These are the wind penetration level, transmission capacity, and the demand load factor, representing the factors that. The impact of each factor on congestion costs and generator load factor is examined by varying the values of the three factors.

The test system used for this study is illustrated in Figure 2. It is intended as a much simplified representation of the GB transmission system. Bus 1 and bus 2 represent two areas with different generation and load capacities. Area 1, which contains bus 1, has a high installed generation capacity but a low demand. Conversely area 2, which is linked to bus 2 has low generation and high demand. There are three generators in the system, two of which, generator 1 and 2, are thermal generators, and the third is a wind generator. Generators 1 and 3 are connected to bus 1, and are for most of the time behind a transmission constraint. Generator 2, which is the more expensive thermal generator, is connected to bus 2, it is required when there is insufficient generation at bus 1 to meet demand, or the transmission circuit is congested. The parameters for the generator capacities,

transmission capacity and peak demand of the test system are given in Table 4. The output assumed for wind generation and demand are taken from actual historical data.

Figure 1: Two-bus test system

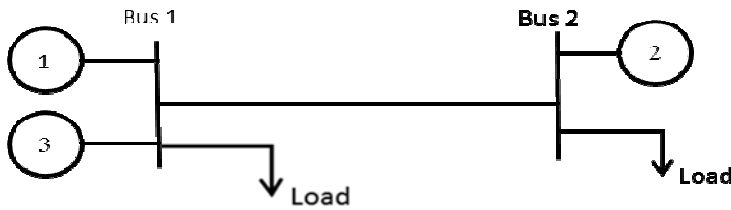


Figure 2: Two-bus test system

Table 4: Two-bus test system parameters

Bus 1					Transmission Capacity	Bus 2				
Thermal Generation		Wind Generation		Load		Thermal Generation		Wind Generation		Load
Price	Capacity	Price	Capacity		30	Price	Capacity	Price	Capacity	
Low	150	0.01	50			100	High	50	-	-

The principal assumptions for the model are:

- Thermal generation will be available whenever it is required subject to its rated capacity, which is given in MW in the table;
- Wind generation output is derived directly from the Met office wind speed data for 2011;
- Generator prices are such that generators connected at bus 1 will be despatched first to meet demand, with any resultant congestion being in the direction from bus 1 to bus 2;
- The branch between bus 1 and bus 2 represents the transmission network and is taken to have an appropriate impedance;
- A transmission constraint arises when the transmission capacity limits the power transfer from bus 1 to bus 2;
- Transmission losses and voltages are not considered in the study;
- The demand profile is taken from historical data for the GB power system in 2011;
- Demand profiles for loads at each bus are the same, which implies that the peak demand at bus 1 will be simultaneous with the peak at bus 2.

The simulation is made using Matpower with a DC optimal power flow. Generator offer and bid prices are set equal to their marginal generation cost

The constraint costs are simulated through two successive economic dispatches for each of the 17,520 settlement periods over the course of a year. The first

economic dispatch is executed without consideration of the transmission capacity which represents the final physical position notified prior to gate closure. However, if the transmission capacity is exceeded then the generation is re-dispatched by reducing the output of the cheaper generation at bus 1, and increasing the output of the expensive generation at bus 2 until the overloading condition is resolved, i.e. Bid off generation at its marginal price in Bus1, and Offer On generation at Bus 2 at the SRMC. The congestion cost is defined as the cost of resolving the system constraints. Note that no premium is applied to bids and offers in this study, the constraint costs would be higher if these were included.

The model is then used to explore how wind penetration, transmission capacity, and demand load factor will impact the costs of resolving system congestion and be reflected in generator out-turn annual load factor.

### 2.3 Wind penetration impact on congestion cost & load factor

In order to examine the impact of the wind penetration level, the proportion of wind in the generation mix expressed on a per unit basis is varied between 0.05 to 0.71 times the wind capacity (50MW) of generator 3, whilst the installed capacities of the other generation technologies remains unchanged.

Figure 3 illustrates how the congestion cost changes as the wind penetration level increases from 2.5MW to 35.5MW. Initially the congestion cost increases as the transmission constraint is sustained over a longer period. Eventually the output from the wind generator cannot be transferred to the load centre, and at this point it is necessary to curtail the wind output and the constraint cost begins to decrease (in this study it is assumed that there is no cost to curtail wind, if a premium for Bids for the wind generation is used, then the constraint cost will rise when the curtailment of wind starts).

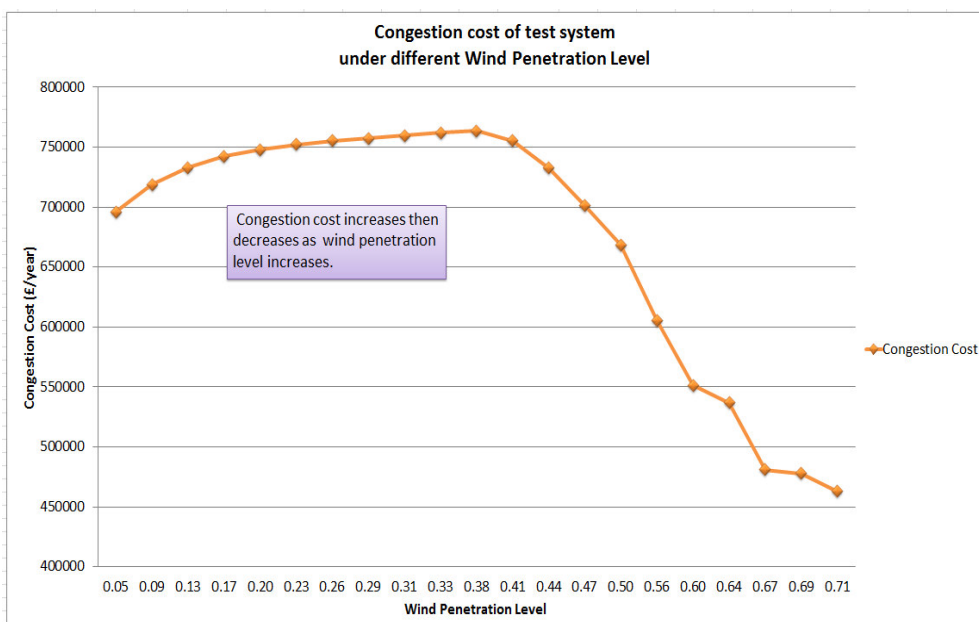


Figure 3: Congestion cost of test system under different wind penetration level.

Figure 4 then depicts the accompanying change in generator load factor with increasing wind generator penetration. The load factor of wind generation (green points in Figure 4) remains constant (at 0.33) until the total congestion cost hits the maximum value corresponding with the 0.38 wind penetration level. Before the maximum congestion is reached the cheaper thermal generation at bus 1 is dominant in determining the transmission capacity utilisation with wind generation replacing the cheaper thermal generation as the wind penetration level increases. The price difference between wind generation and expensive thermal generation drives a higher congestion cost. After the critical peak congestion point the load factor of wind generation starts to decrease, and the wind generation becomes a dominant factor in congestion alongside the cheaper thermal generator.

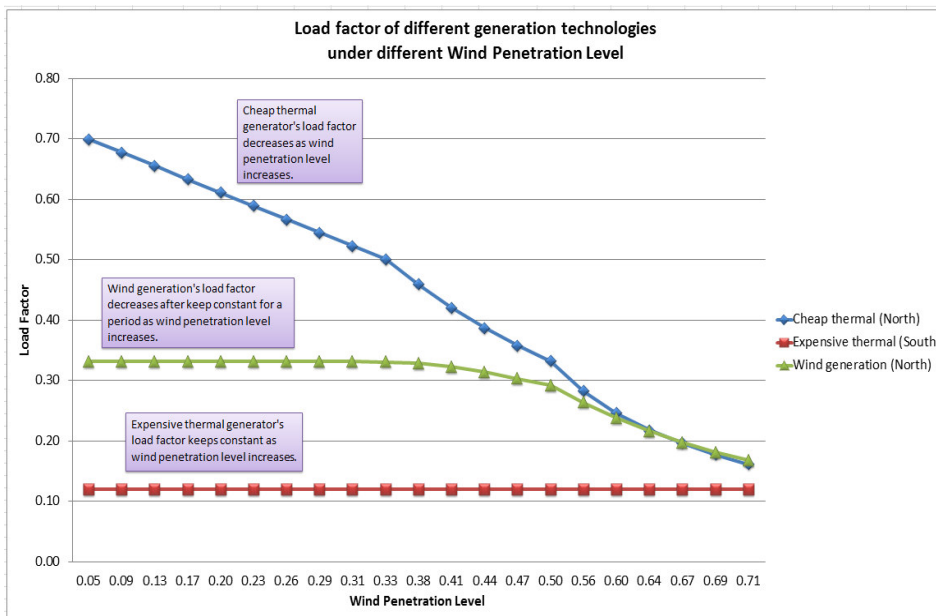


Figure 4: Generator load factors at varying levels of wind penetration

The load factor of the cheaper thermal generation (blue points in Figure 4) also decreases with the increase in wind penetration. As the transmission capacity must be shared between wind and cheap thermal generation it is inevitable that an increase in wind generation capacity will lead to a reduction in the output of the cheaper thermal generation.

The load factor of the expensive thermal generator (red points in Figure 4) remains constant since when demand exceeds the transmission capacity the excess of the demand above the transmission capacity must be met by the more expensive thermal generation.

Figure 5 combines figures 3 and 4 and shows the relationship between the congestion cost and load factor as the wind penetration level increases, which is depicted as a series of points which follow the direction of the arrow. As the wind penetration level increases, the relationship between congestion costs and load factor varies significantly for different generation technologies; the direction of change is shown by the three lines following the direction of arrow.

Before the wind penetration reaches 0.38, the congestion cost rises with decreasing load factors for both of the two generators (wind and low cost thermal)

that are behind the constraint. Beyond a 0.38 penetration when wind curtailment starts to be exercised, the congestion cost decreases with decreasing load factors for the two generators behind the constraint. The expensive generator displays a very different picture. Its load factor remains constant as the congestion cost decreases.

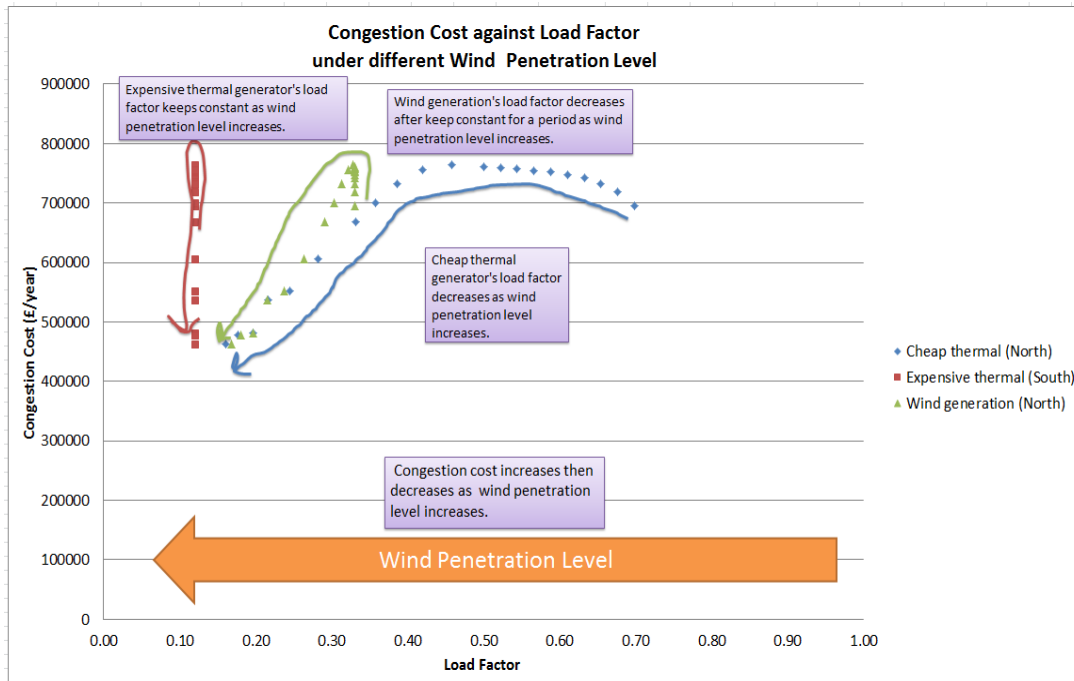


Figure 5: Congestion cost and load factor at different wind penetration levels.

The study emphasises that the load factors of thermal generators will depend upon their location relative to a transmission constraint. The expensive thermal generator that is in front of the transmission constraint has a load factor that is almost constant as the wind penetration changes. The cheaper thermal generation that is behind the transmission constraint has a load factor that decreases as the wind penetration increases and it shares the same transfer capability with the wind generation. The relationship between the expensive thermal generator load factor and the congestion cost is constant, but the relationship between cheaper thermal generator load factor and congestion cost shows a two part curve divided at the point of the peak congestion cost when wind penetration hits 0.38.

The load factor of wind generation depends on both its relative location to a network constraint and its penetration level. Before its penetration hits 0.38 and no generation curtailment is required, load factor is a constant driven by the availability of its natural resource. However, beyond the 0.38 penetration level as wind generation curtailment becomes necessary its load factor reduces as a result of the network constraints.

It is thus starkly apparent that **the relationship between load factor and congestion cost under different wind penetration level is far from linear.** One generation technology can significantly influence the load factor of another generation technology. Generalising the results from this study makes it apparent that **this relationship will vary significantly for generators of different types, locations, prices and the associated low carbon background.**

## 2.4 The impact of transmission capacity on congestion and load factor

The impact of the available transmission capacity on the year-round congestion cost and generator load factor was investigated by varying the transmission capacity in 5 MW steps from 100 MW to 150 MW. Figure 6 shows how congestion cost decreased as the transmission capacity increased. Figure 7 then tracks the change in the load factor for each generation technology.

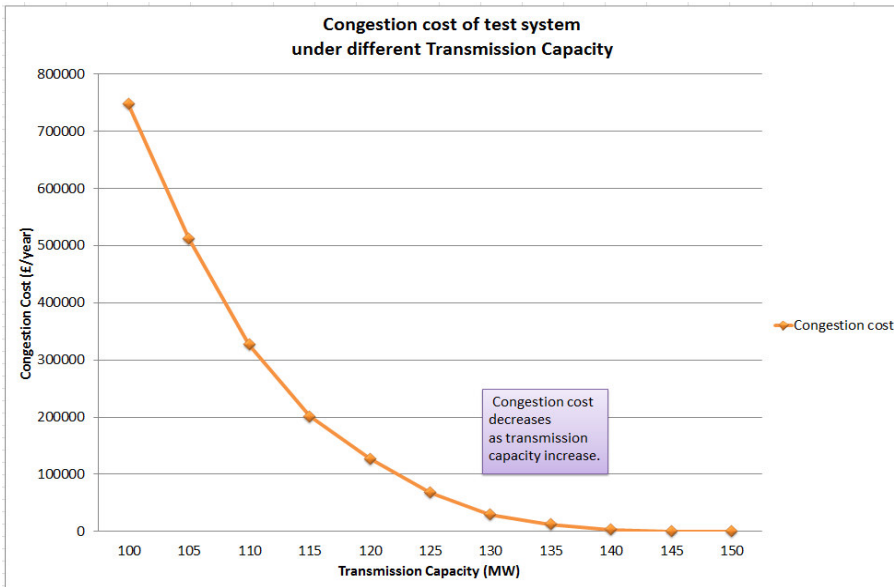


Figure 6: Congestion cost for increasing transmission capacity

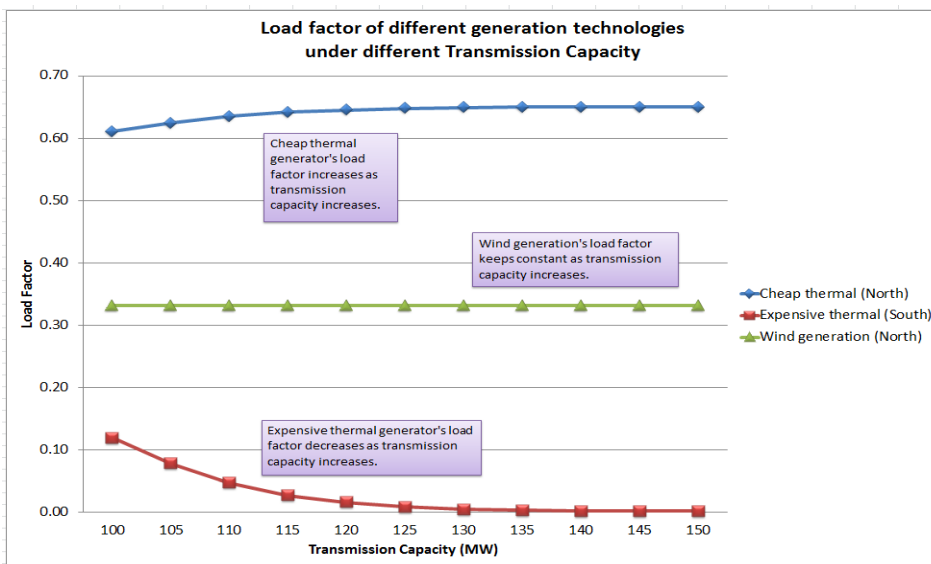


Figure 7: Load factor of generation technologies at different transmission capacity.

As transmission capacity increases the load factor of the cheaper thermal generation (blue points in Figure 7) also rises as it is able to produce more output without being constrained. Conversely the load factor of the expensive thermal generation (red points) reduces. The load factor of wind generation (green points in figure 7) remains constant with the increase in the transmission capacity reflecting the priority for its despatch. This result confirms the view that the annual load factor of individual generators is an output parameter that depends on the

generator's price structure, its location, and the value of the transfer capacity between areas.

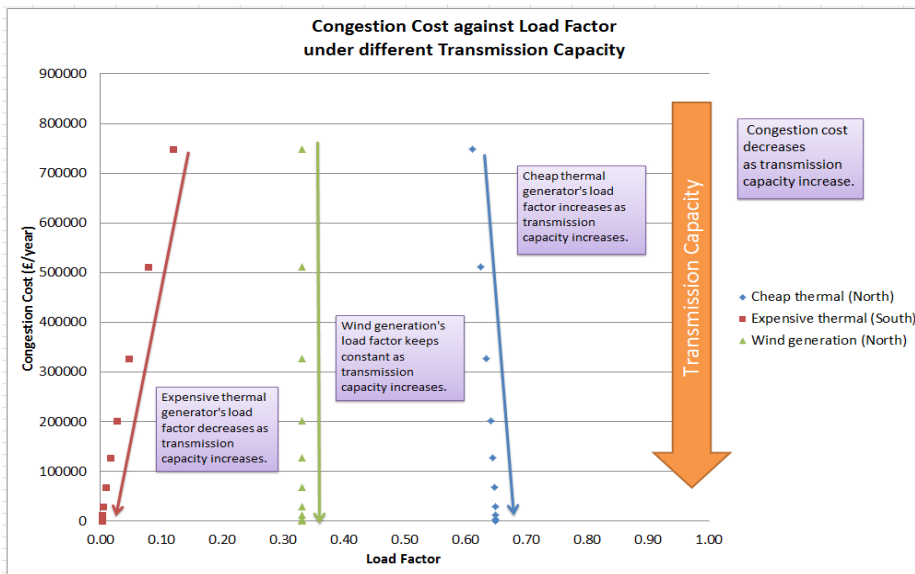


Figure 8: Congestion cost and load factor for different transmission capacities

Figure 8 provides a scatter plot of the congestion cost for each generation technology against load factor. The trajectory for each technology shows the variation with increasing transmission capacity. Each generator technology shows a linear relationship between load factor and transmission capacity although **whether the correlation is positive or negative now depends on the location of the technology in relation to the constraint. Utilising load factor as a measure of congestion cost without recognising the location of a network constraint would clearly be a flawed assumption.**

### 2.5 The impact of demand load factor on congestion cost & load factor

The effect of demand load factor on the congestion cost and generator load factor is explored by varying the demand load factor between 0.63 to 0.70 times the peak demand in incremental steps of 0.01. For example this might result from an increased demand side response. In the model it is implemented by reducing the level of peak demand whilst retaining a constant level of annual consumption, thus effectively representing load shifting between time periods.

Figure 9 shows how the congestion costs increase as the demand load factor increases. Figure 10 then depicts how the load factors of the different generation technologies change as the demand load factor increases, and Figure 11 illustrates the relationship between congestion cost and generator technology load factor for changing demand load factor.



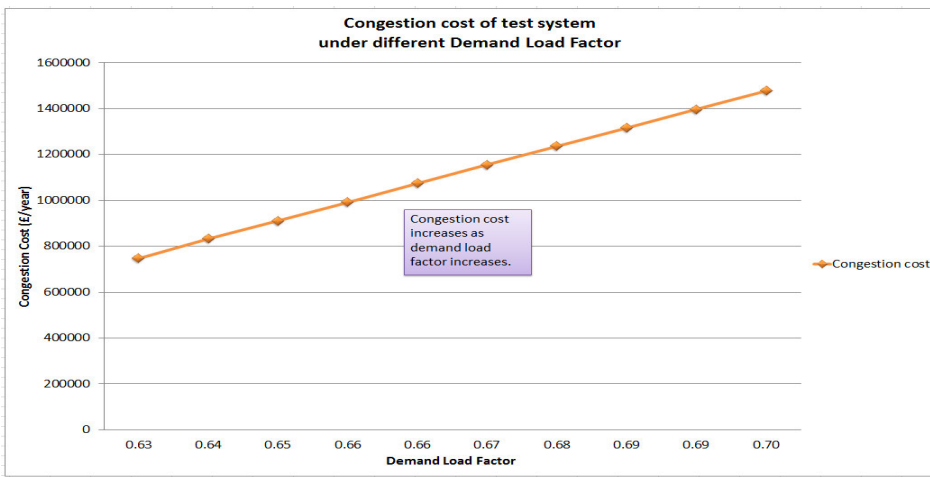


Figure 9: Change in congestion cost for increasing demand load factor.

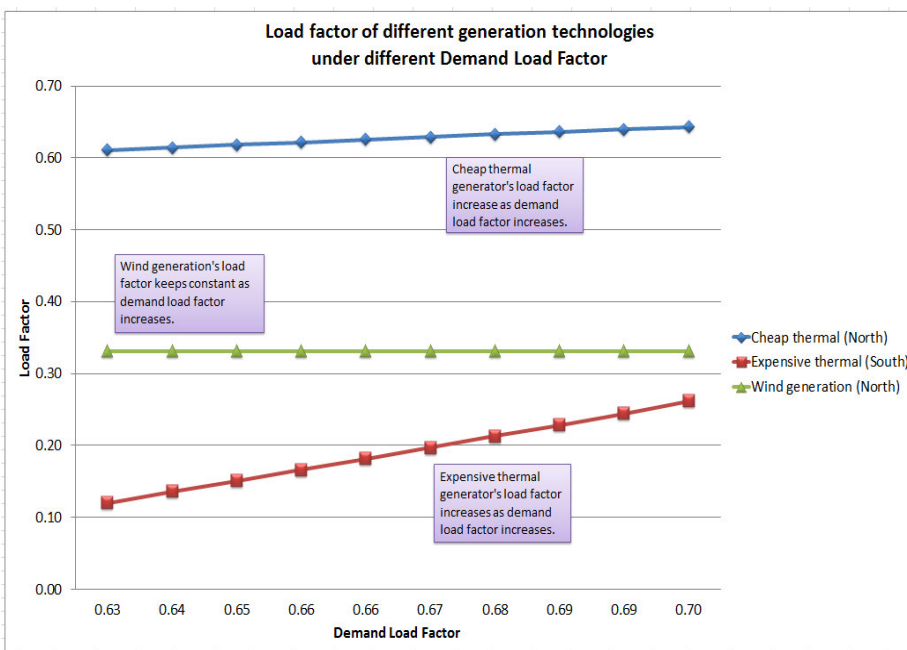
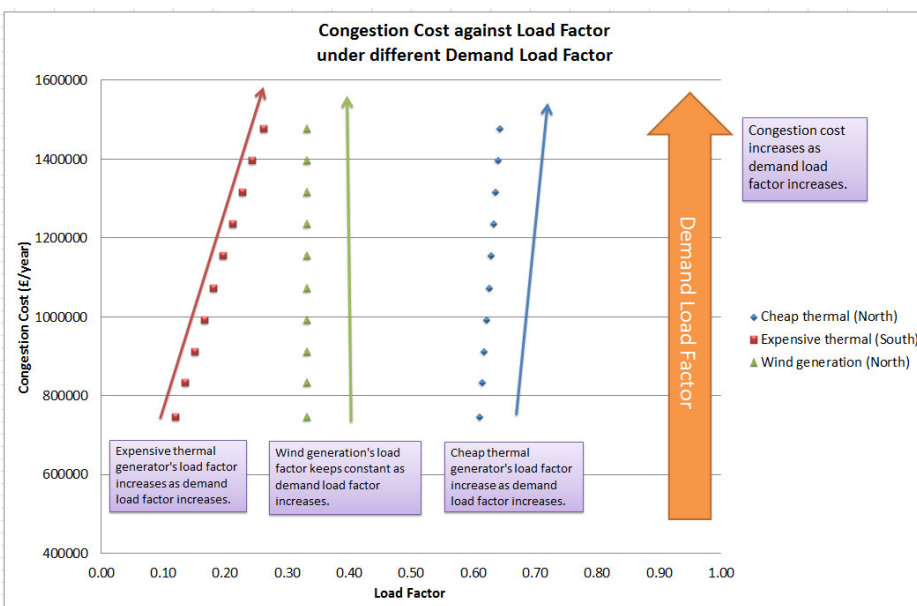


Figure 10: Generator technology load factors for increasing demand load factor



*Figure 11: Congestion cost and generator load factor under different demand load factors.*

In this simple 2 busbar system the relationship for each generator technology between congestion cost and generator load factor with a changing demand load factor is linear. Both the low cost thermal generation at bus 1, and the expensive thermal generation at bus 2 (respectively the blue and red points in Figures 10 and 11) show an increasing congestion cost with load factor. This is because as more electricity per peak MW is required as demand load factor increases, the additional electricity has to be met by the thermal generation.

For wind generation (green points in Figures 10 and 11), the installed capacity of wind generation and wind characteristics are fixed, and wind is dispatched as long as it is available. Thus the wind generator load factor is not affected by a changing demand load factor.

## **2.6 Conclusions**

**These studies have illustrated that the load factor of a single generation technology is not uniform across the system but will be shaped by different generator and demand parameters, and features of the transmission system.**

The costs of congestion and generator load factors are the results of these varying combinations. For generation there are a variety of technologies, production prices, generation capacities, and locations. For the transmission network there are differing transmission transfer capacities, impedances and lengths. For demand there are varying load profiles and durations, and the timing of peak demands as subsequently reflected in the demand load factor.

**All these features will combine to impact congestion costs and generator load factor in different ways.** Whilst based on a relatively simple representation of the GB system our studies have demonstrated that under different network, generation and demand conditions the relationship between congestion costs and load factor will vary significantly. **The relationship most certainly can not be assumed to be linear.**

Instead system congestion tends to be directional with the majority of its associated cost incurred across the B6 boundary and within Scotland, as evidenced by the figures reported by NGET. **Employing load factor as a surrogate for the cause of this congestion would smear the consequence for what is a highly localised problem across all boundaries and throughout the year. It cannot provide the necessary economic message for reducing congestion, and it certainly would not reflect the costs of congestion as required by SLC 5.5(b).**

**Southern based controllable CCGT generation would be under rewarded on the basis of its annual average load factor even though it was contributing fully to the relief of system congestion.** A more economically efficient arrangement would be one that targeted TNUoS charges and credits to **periods** and **locations** where generator output either **compounded** or **alleviated** congestion. However, this implies a time of use feature in TNUoS charges rather

than linking congestion costs with generator class load factors within the methodology.

### **3. Dual versus single background for deriving TNUoS charges**

#### ***3.1. Introducing the study***

An important feature in the CMP213 proposals for an improved ICRP (IICRP) methodology is the introduction of dual backgrounds that reflect the trade-off between network investment and constraint costs which is now recognised in the SQSS. In the methodology that has been advanced through the working group, a Peak Security background is intended to reflect the capacity required to meet the peak demand, whilst the Year Round background is intended to reflect the year round congestion costs in the system.

As we have noted in the introductory section of this report we are concerned that NGET has been instructed to reflect the dual criteria that are now embodied in the SQSS as dual backgrounds in the charging methodology.

#### ***3.2. Study framework***

For the purpose of this study a three bus network has been devised to represent the GB transmission system. Its principal features include the B6 and B15 transmission boundaries that are the most heavily congested of all system boundaries. The study derives a congestion cost duration curve for the system that indicates the degree and duration of the congestion over the 17,520 settlement periods. The study explores the characteristics of the various segments of this curve in detail, and quantifies the share of B6 and B15 congestions in each segment of the curve, and the times when the congestion is mostly likely to occur. For the year round background to create a reasonable surrogate on which to reflect the costs of the system it would be necessary for both boundaries to display a similar representation of the costs of congestion across the year. In fact the outputs from the study clearly indicate that congestion at different boundaries of the transmission network differ hugely in their magnitude, timing, and duration.

The three bus model developed for this study is shown in Figure 12. It represents the GB transmission network as three zones separated by the B6 and B15 boundaries, which together account for more than 80% of all system congestion costs. It thus provides an approximation of the year-round congestion costs in the GB power system. The two boundaries divide GB into three areas; Scotland, England & Wales (excluding Zone 15), and Zone 15.



- The proportion of each generator technology in the total generation capacity is retained with no new capacity contemplated for any generation technology
- Wind generation output follows the historical wind speed data recorded in 2011 by the Meteorological Office
- Interconnector behaviour is simulated as generation and demand as the GB system demand changes. When demand is high (over 80% of peak), the interconnectors are deemed to be unavailable on the basis that other systems will also be experiencing high demand. When the demand is modest from 50% to 80% of peak, the interconnectors operate at their rated capacity as a generator. When the demand is below 50% of peak, the interconnectors are recognised as demand representing the exporting of power at this time
- Maximum transfer capacities for the B6 and B15 boundaries are taken as 2,800 MW and 6,400 MW respectively in accordance with their performance in 2011
- Transmission losses are ignored
- System peak demand of 58,130MW is split across the three zones with Scotland accounting for 5,697 MW, E&W for 50,416 MW, and Zone15 for 2,017 MW
- The demand profile is taken from the GB historical data for 2011 provided on the NGET website, although the same profile is assumed for each zone
- Electricity prices for each generation technology use the typical values in the ELSI excel document, with prices in Scotland and Zone 15 set lower than prices in England & Wales
- The congestion direction on B6 is from Scotland to England & Wales, and on B15 from Zone 15 to England & Wales.

The same methodology as employed for the two busbar model is followed. At times when only B6 is congested the corresponding congestion cost is allocated to B6; similarly with B15. When Both B6 and B15 are congested, the relevant power flows are used to allocate the congestion cost between B6 and B15.

### ***3.3. Congestion cost duration curve***

Figure 13 is the congestion cost duration curve derived from the analysis. It is constructed by rearranging the congestion cost observed in each settlement period from the highest to the lowest. Extremely high congestion costs only occur for a very small duration (about 12 hours), after which the congestion cost in each settlement period declines exponentially to zero.

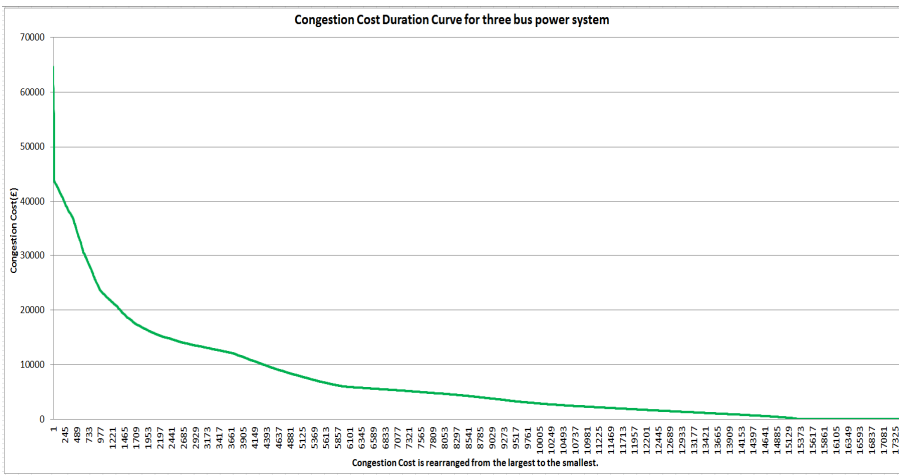


Figure 13: Congestion cost duration curve for three bus power system

The congestion duration curve can be divided into five parts representing a five piece-wise linear curve, as shown in Figure 14. The boundaries between each part are not absolute. For example some settlement periods in part 3 have the same congestion circumstances as in parts 2 and 4. The various parts are characterised by:

- Part 1 covers settlement periods when extremely high congestion costs occur. The range of congestion cost in this period is from £75,000 to £44,000 per settlement period. In these settlement periods, only the B6 boundary is congested
- Part 2 encompasses most settlement periods when both B6 and B15 are congested. The range of congestion cost is from £44,000 to £36,000
- Part 3 includes settlement periods when both boundaries are congested, or when either boundary is individually congested. The range of congestion cost in these periods is from £36,000 to £4,000.
- Part 4 includes mainly settlement periods when B15 is congested, and some when B6 is congested. The range of congestion cost is from £4,000 to £3,000.
- Part 5 includes most settlement periods when B6 is slightly congested.
- Beyond Part 5 there is no congestion for a little over 12% of the year.

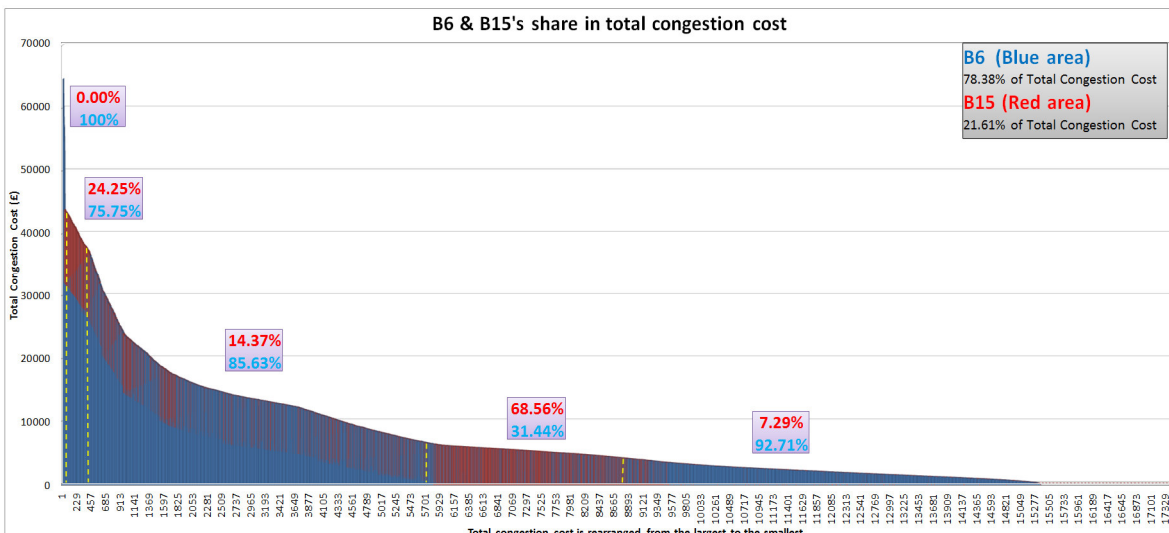


Figure 14: B6 and B15 share in total congestion cost

Table 6: Congestion between B6 and B15 under different part of congestion duration curve

	Number of settlement periods	B6 Congestion Cost £M	B15 Congestion Cost £M	Total Congestion Cost £M	Congestion share between different parts	Proportion of B6 in TCC	Proportion of B15 in TCC
Part 1	23	1.3	0	1,3	1.06%	100.00%	0.00%
Part 2	394	12.0	3.8	15.8	12.87%	75.75%	24.25%
Part 3	5427	67.4	11.3	78.7	63.91%	85.63%	14.37%
Part 4	3042	4.8	10.7	15.5	12.57%	31.44%	68.56%
Part 5	8634	10.9	0.9	11.8	9.58%	92.71%	7.29%
Total	17520	96.5	26.6	123.1	100%	78.38%	21.62%

The above table shows the share of congestion cost between B6 and B15 as determined from the areas under different parts of the congestion duration curve. The overall annual congestion cost described by the model is £123 million.

- In part 1 B6 contributes to all congested periods whilst B15 is not congested
- In part 2 when both B6 and B15 are congested their congestion cost shares are different. B6 contributes 75.8% of the congestion cost whereas B15 contributes only 24.2%.
- In part 3 B6 contributes to 85.6%, while B15 contributes 14.4%.
- In part 4 when B15 contributes to most of the congestion, the position is reversed with B15 accounting for 68.6% of the total whilst B6 accounts for only 31.4%.
- In part 5 when B6 is slightly congested in most of settlement periods, B6 become dominated again at 92.7% of the total.
- Overall the B6 boundary incurs 78.4% of the total congestion cost, and B15 21.6%.

The different parts of the congestion cost duration curve reflect different congestion scenarios. Under different scenarios, the role of the same generator may change. A generator which contributes to congestion within one scenario may help eliminate congestion in another scenario. Even for the simple three bus representation of the GB transmission system it is necessary to have at least five different congestion periods to reflect the various aspects of year round congestion. The inevitable conclusion is that employing only two backgrounds is



wholly inadequate in producing even the crudest representation of system performance and costs.

### 3.4. The nature of boundary congestion

The following figures explore the intensity, location and timing of congestion costs as derived from the 3-bus model. The first figure is a plot of congestion cost for each settlement period from 1st Jan 2011 to 31st Dec 2011, and the second indicates the same picture but as a scatter diagram to separate the various points. A colour code is used to distinguish periods when only the B6 boundary is congested (blue points) from times when only the B15 boundary is congested (red points) and times when both boundaries are congested (green points). In general the congestion across the B6 boundary is significantly higher than across the B15 boundary. These diagrams illustrate that congestion is not uniform across the system.

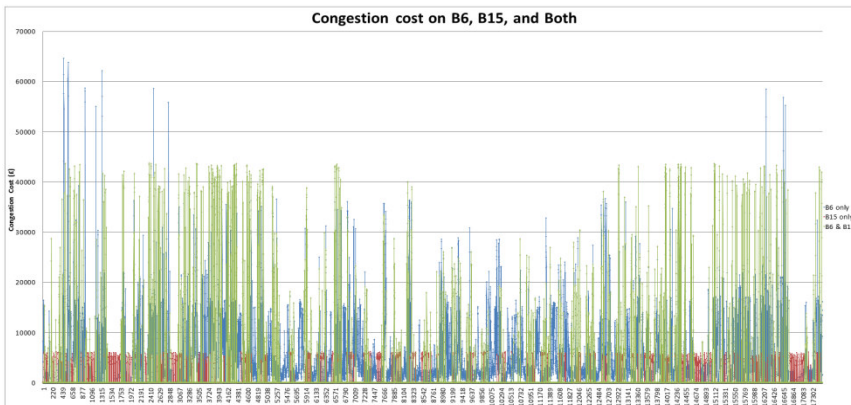


Figure 15: Year round congestion cost over the system

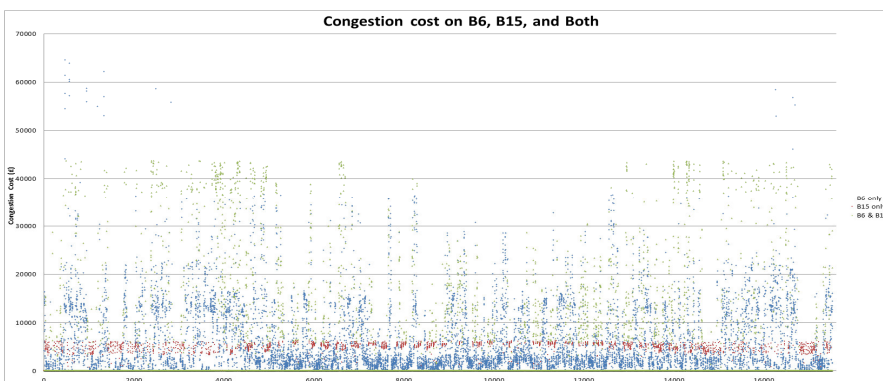


Figure 16: Scatter plot of year round congestion

The following three figures further illustrate the diversity in the timing of the congestion periods during calendar 2011 by indicating the times of congestion at the B6 boundary, the B15 boundary, and when both boundaries are congested.

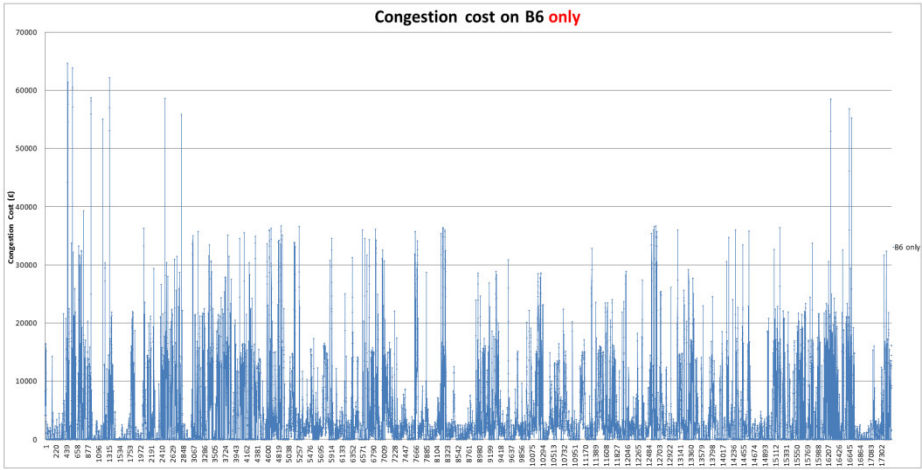


Figure 17: Year round congestion on B6 only

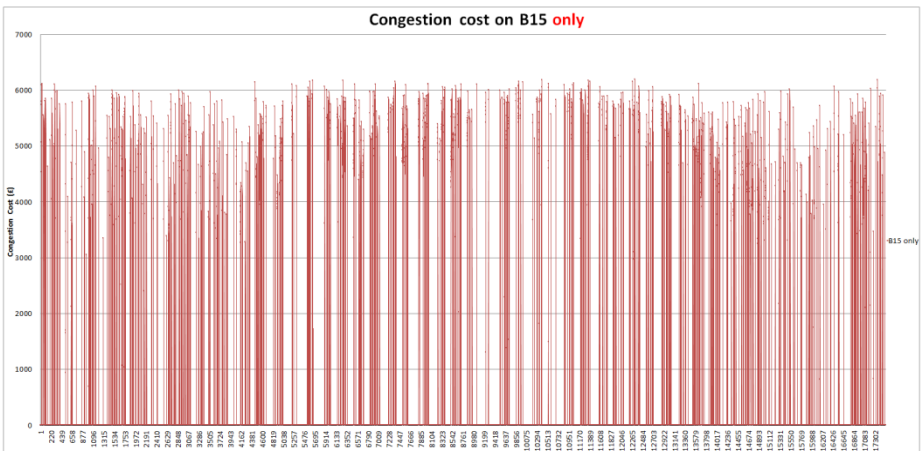


Figure 18: Year round congestion on B15 only

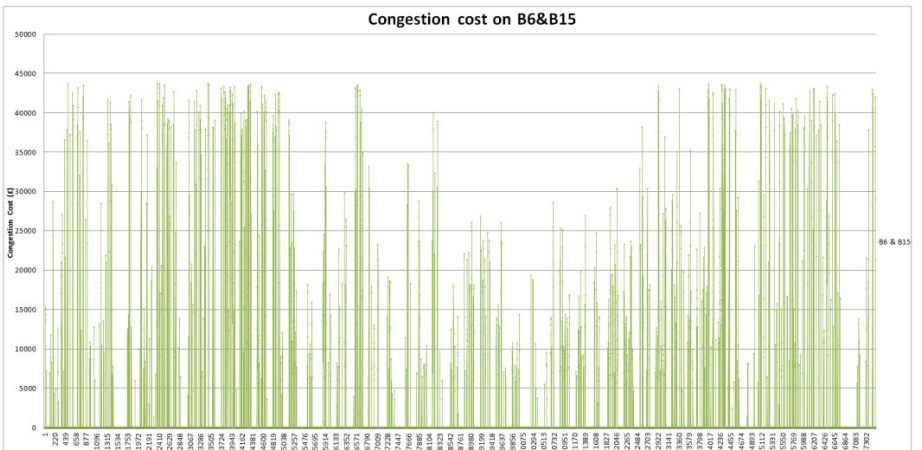


Figure 19: Year round congestion of B6 & B15 together

The proportion of time the boundaries are congested, either singly or together are tabulated below. The probability that congestion will occur on a 3-bus representation of the GB system is 87.8%, although the B6 boundary is responsible for more than 80% of this figure.

Table 7: Proportion of time each boundary is congested

Congestion situation	Number of settlement periods	Proportion in all settlement periods	Proportion in congested settlement periods
System	15,379	87.8%	100.0%
B6 Only	11,018	62.9%	71.6%
B15 Only	2229	12.7%	14.5%
B6 & B15	2132	12.2%	13.9%

### 3.5. The timing of congestion

The next five figures explore the frequency and time of day when congestion is arising at each boundary, or combination of boundaries, for each part of the congestion cost duration curve shown in Figure 1.



Figure 20: Part 1 - Frequency and timing of congested settlement periods

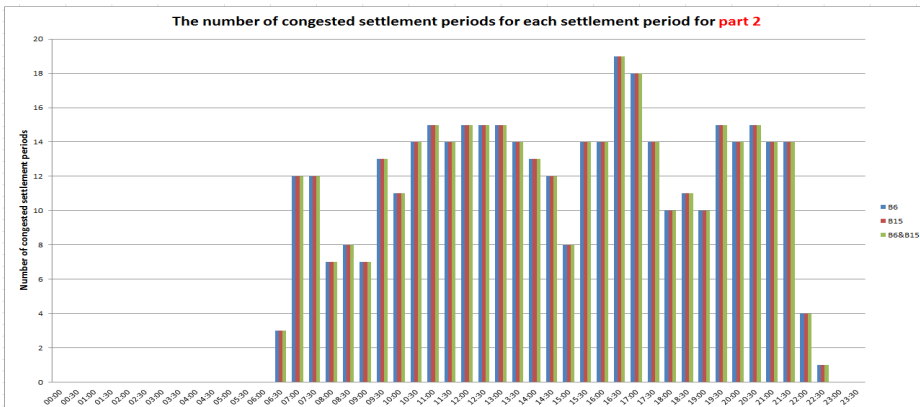


Figure 21: Part 2 - Frequency and timing of congested settlement periods



Figure 22: Part 3 - Frequency and timing of congested settlement periods

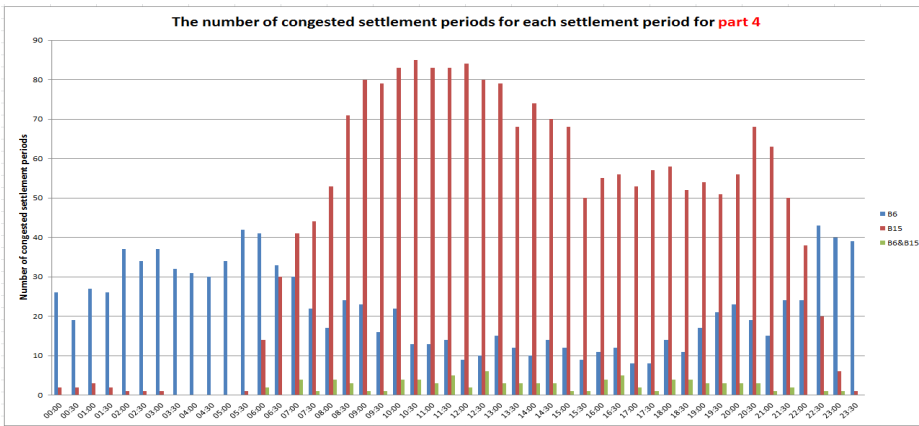


Figure 23: Part 4 - Frequency and timing of congested settlement periods



Figure 24: Part 5 - Frequency and timing of congested settlement periods

Part 1 of the congestion cost duration curve demonstrates exceptionally high levels of cost but these are focussed into the six settlement periods around the system peak. They are associated exclusively with the B6 boundary.

In part 2 of the congestion curve, when both boundaries are congested the timing of the congestion becomes more diffuse but is still associated with the day time and evening hours.

Over part 3 of the curve the frequency of congestion on the B6 boundary tends to appear like the typical daily load curve, whereas the B15 boundary is only congested during daytime and evening hours as it was in part 2. When B15 is congested then B6 is generally congested also. The B15 congestion may be affected by the interconnector assumption which is assumed to be exporting power when demand is high.

During part 4 of the curve the B15 boundary shows the same pattern of congestion as for part 3 but the B6 boundary becomes congested mainly during off-peak hours. The incidence when both boundaries are simultaneously congested becomes relatively small.

Finally in part 5 of the curve the congestion of the B15 boundary falls away. The predominance of congestion across the B6 boundary now migrates to the off peak settlement periods.

### **3.6. Conclusions**

In this section, we have illustrated that year-round congestion costs is not uniform across the system but varies significantly in magnitude, time and boundary location. These differences in congestion magnitude, time, and location are not reflected in the CMP213 proposals. Rather, the use of a single year-round scenario at the time of peak generation outputs and annual load factor to reflect year-round congestion costs essentially assumes that all boundaries have the same level of congestion throughout the year. Employing load factor as a surrogate for the cause of congestion would smear the consequence for one boundary across all boundaries and in all time periods. It cannot provide the necessary economic message for reducing congestion, and it certainly will not reflect the costs of congestion in accordance with SLC 5.5. The inevitable consequence of adopting the IICRP proposals is a further increase in congestion cost, which is in direct opposition to the purpose of project Transmit.

An arrangement that could target TNUoS charges and credits in periods and locations where generator output either contributes to, or relieves congestion would be a constructive approach. However, this implies a time of use feature in TNUoS charges that is developed against multiple backgrounds rather than simplistically linking it to generator annual load factors.

However if multiple background with their respective time periods and duration are judged to be too complicated then the existing IICRP method should be retained for the sake of ease of understanding rather than further dilute the economic signal. This would be a better solution that would accord with the principles of cost reflection, rather than creating a dual background which would be a retrograde step in the reflection of costs and the provision of useful economic signals.

## Annex 14 – Papers presented to Workgroup in support of potential alternatives

The following papers were presented to the workgroup in support of potential alternatives. They are as follows;

- 14.1 Generic sharing factor
- 14.2 Hybrid ALF
- 14.3 Remove 100% of the converter costs from the expansion factor
- 14.4 Use of generic percentages for the exclusion of the HVDC converter station costs
- 14.5 Removing specific AC equivalent costs
- 14.6 HVDC –The Benefits of Voltage Source Converters (VSC)
- 14.7 Pseudo AC approach
- 14.8 Treatment of HVDC bootstrap costs as onshore AC transmission technology cost when calculating the expansion factor
- 14.9 Setting expansion factors at T-4
- 14.10 Briefing Note for 7th August 2012 meeting on HVDC removal of convertor station costs

## 14.1 Generic sharing factor

### *Description of the original sharing factor*

The Original proposal is for the Year Round element of the TNUoS tariff to be scaled by a generator specific sharing factor, based on the annual load factor (ALF) of the specific generator. The approach calculates this generator specific ALF by using the last five years' load factors for the individual power station concerned and calculates an average of the middle three values (i.e. ignore the highest and lowest values). The proposer believes this approach is required to better reflect the impact that generators with different plant characteristics have on the incremental cost of transmission network capacity.

### *Concern with original sharing factor approach*

We have been undertaking analysis to understand how the use of the proposed ALF methodology will affect the pricing decisions of generators, particularly short run decisions. Under the current ICRP methodology the quantity that a generator produces will not affect its transmission charge (at least not directly). However, this is no longer the case when the proposed sharing factor is employed.

To illustrate this, we have made a number of simplifying assumptions to isolate the impact of the proposed sharing factor on future generation costs<sup>35</sup>. We consider a simplified scenario for two hypothetical generators; Generator A and Generator B. We assume the following elements are identical for Generator A and B:

- Capacity (TEC) of 2000MW
- The year round tariff is held constant year on year
- The previous five years load factors are 75% (therefore the ALF is 0.75)

The only difference between Generator A and B is that Generator A has a year round tariff of £2/KW and Generator B of £5/KW.

Now assume that in Year 1 both Generator A and B produce more power so that their load factor for Year 1 is 80%. If this increase in production represented a blip and production in Years 2 and beyond returned to a load factor of 75% there would be no effect on the Generator's Year Round charge in future years (as the 80% load factor would be removed from the sharing factor calculation as an outlier).

But, if in Year 2 the load factors for Generator A and B remained at 80% this would result in a higher ALF and thus a higher Year Round charge. However, the increased charge would not materialise until Year 4 but would remain for a further three years (assuming both Generator A and B revert to a load factor of 75% after Year 2 and beyond). The increased charge for Generator A would equal £66,667 per year and for Generator B would equal £166,667 per year. Please note that the opposite effect would be observed if plant load factor fell. The effect is illustrated below in Tables a) and b).

---

<sup>35</sup> Note we only consider here the year round tariff element as this is the only part of the TNUoS tariff which has the sharing factor applied to it.

Table a)

Generator A	TEC = 2000M W	Year Round Tariff =£2/KW												
Year	-5	-4	-3	-2	-1	0	1	2	3	4	5	6	7	8
Load Factor	0.75	0.75	0.75	0.75	0.75	0.75	0.80	0.80	0.75	0.75	0.75	0.75	0.75	0.75
ALF							0.75	0.75	0.75	0.77	0.77	0.77	0.77	0.75
Year Round Charge							£3m	£3m	£3m	£3.07m	£3.07m	£3.07m	£3.07m	£3m

Table b)

Generator B	TEC = 2000M W	Year Round Tariff =£5/KW												
Year	-5	-4	-3	-2	-1	0	1	2	3	4	5	6	7	8
Load Factor	0.75	0.75	0.75	0.75	0.75	0.75	0.80	0.80	0.75	0.75	0.75	0.75	0.75	0.75
ALF							0.75	0.75	0.75	0.77	0.77	0.77	0.77	0.75
Year Round Charge							£7.5m	£7.5m	£7.5m	£7.7 m	£7.7m	£7.7m	£7.7m	£7.5m



As these increased costs result as a direct consequence of increasing production this represents a variable cost of generation and would need to be incorporated into a generator's Short Run Marginal Cost (SRMC). Consecutive increases in production would lead to an increase in a generator's SRMC, decreases in production a reduction in a generator's SRMC.

It is difficult to fully appreciate the materiality of this effect considering the number of simplifying assumptions made above. However, in isolation, it should be noted that the materiality of this effect increases depending on:

- The size of Year Round Tariff (large values above and below £0/KW)
- The size of the change in consecutive future load factors i.e. the bigger the fluctuation from the ALF sharing factor, the bigger the effect

In any case, despite the simplifying assumptions made above we believe the effect has been sufficiently demonstrated.

This effect is a concern for us as we do not believe that the proposed TNUoS charging methodology should affect short run pricing decisions in the wholesale market in this way. Indeed, the proposer agrees that the sharing factor used should not overly effect operational decisions.

Two potential consequences of implementing the proposed ALF sharing factor are:

- Spark and dark spreads will not be equal throughout GB which could make investment decisions more complicated
- It is likely that the marginal cost of generation will be affected although it is difficult to predict the future direction of costs

To avoid this effect, the direct link between a specific generator's production and the calculation of its transmission charge needs to be broken. One way of doing this is to implement a generic ALF (which may take many forms). The potential options are detailed in the next paragraph.

#### Generic ALF options

There are three main generic ALF options that we have considered:

1. **The background scaling factors set out in GSR-009** (updated when the NETS SQSS is updated). SQSS scaling factors can be found on page 20 of the workgroup report
2. **The generic load factors based on historic data**, put forward in the Original proposal for use when actual metered data is not available (updated at each Transmission Price Control Review). For this option generic data would be derived from the average annual output of all GB generation of a particular fuel type over the last five years, using an identical methodology to that used for the user specific calculation (ALF). An example of generic load factors produced can be found on page 172 of the workgroup report (Table A5.3)
3. Similar to Option 2 but have **broader generation type groupings**. The grouping could be:

Generation Type	Consists of
1. Conventional	Coal, Gas, Biomass, Oil
2. Weather related	Wind, Hydro
3. Pumped Storage	Pumped Storage
4. Nuclear	Nuclear

These approaches would break the link between a generator's production and transmission charge. However, the Proposer and a significant proportion of the Workgroup have articulated concerns that a Generic ALF approach would not be sufficiently cost reflective, in particular, relative to the proposed ALF approach. This concern is discussed in the next paragraph.

#### *Generic ALF and cost reflectivity*

The proposer believes that in order to enhance the existing distance related signal and differentiate between the incremental impact of generation with different characteristics in a simple and transparent manner, the Year Round element of the tariff should be multiplied by a sharing factor based on the annual load factor of a generator. The proposer has deemed that in order to remain cost reflective, any proposed sharing factor needs to be reflective of the implicit assumptions made when planning transmission network capacity as it is these assumptions that ultimately lead to the costs that the tariff is attempting to reflect. As such the proposer believes that the proposed ALF methodology is representative of the assumptions made by TOs when planning transmission investment. Conversely, the proposer believes that using generic sharing factors would not be sufficiently cost reflective and, in particular for the approach based on NETS SQSS scaling factors, are inappropriate for calculating an individual generator's contribution to the need for this transmission investment.

To demonstrate the point above, analysis was undertaken comparing the cost reflectivity of the proposed approach and the two potential generic approaches. This analysis is summarised on pages 64 and 65 of the workgroup report. In conclusion, whilst the use of generic, historic, load factors by generation plant type is shown to be better than the GSR-009 scaling factors, it was noted by the Workgroup that increased granularity of plant type would be required in order to achieve something that was approaching the cost reflectivity of the annual load factor based approach proposed in the Original. In effect, the proposed approach was found to be most cost reflective, the SQSS approach least cost reflective and the other generic approach somewhere in the middle. On face value, and in isolation, this opinion may be correct.

However, we believe it is important to consider how the claimed enhanced cost reflectivity of the proposed approach will be reacted to by generators to fully evaluate the merits of the proposed approach. The proposer states that the purpose of enhancing the cost reflectivity of the year round tariff is to allow individual generators to take the cost of transmission into account when making decisions about where to locate and when to close their plant. Assuming for a moment that the proposed approach is more cost reflective<sup>36</sup>, it is unclear how generators and developers will be able to internalise the cost component associated with the ALF methodology and utilise it in entry and exit decisions. We do not believe the signal that the proposer is attempting to deliver has been sufficiently well articulated. But presumably, the methodology should encourage generators to only produce an increment of power if the revenue associated with this increase is greater than the incremental cost associated with an increase in transmission cost? If this is the case the proposed ALF methodology makes this type of decision making process very complicated, not least due to the time lag effect. As such we do not believe that the assumed

---

<sup>36</sup> We do not believe this opinion is particularly conclusive however to allow the discussion to progress we assume it is valid.

enhanced cost reflectivity of the proposed ALF methodology would actually deliver tangible benefits in terms of replicating the cost optimisation process delivered by competitive markets. Indeed the proposed ALF methodology introduces new economic incentives into the wholesale market (via a generator's SRMC) which we believe are unnecessary and inappropriate.

Based on the above paragraph we consider that a generic ALF methodology has considerable benefits against the proposed ALF approach. A generic approach removes the link between production and transmission charging preventing new incentives being introduced in to the wholesale market. As a consequence the generic ALF approach would make transmission charges far more stable and thus allow users to more easily factor in these charges when taking entry and exit decisions. Moreover, the claimed benefits of the proposed approach in terms of cost reflectivity should not be expected to materialise in the form of a more efficient total system operation (generation and transmission).

Of the three generic approaches considered above, the SQSS option may be considered to be more reflective of transmission planning assumptions (although noting the Proposer's reservations), but may be considered by some to be particularly lacking cost reflectivity. The broader generation type groupings approach would most clearly break the production and charging link but also may be considered to be significantly lacking in terms of cost reflectivity. With regards to the generic historic approach, we consider this represents a good compromise solution which balances the cost reflective arguments made by some with the need to break the link between production and transmission charges. All the approaches suggested have both advantages and disadvantages.

A benefit of taking these approaches forward is that we should be able to test the hypothesis that the supposed more cost reflective ALF approach indeed has merit relative to a generic ALF approach. By modelling both approaches we would expect that if the proposed ALF approach is more cost reflective than the generic approach, this should result in a relatively smaller expenditure on transmission (both network build and congestion). This will need to be considered alongside cost changes in the wholesale market/generator costs. We do not expect that modelling a generic ALF approach will be particularly labour intensive so this testing should be possible in the current modification timescales.

### *Diversity Method 3*

On a final note, an alternative approach to dealing with the abovementioned concern with ALF would be to adopt Diversity Method 3 which removes the load factor approach. While this has not been developed to principally deal with the above issue it does have the ancillary benefit of breaking the link between generator production and transmission costs.

## 14.2 Hybrid ALF

- National Grid will calculate ALF on the basis of average of the last 5 years (intermittent) or average of last 2 years (controllable) generation by 30 September in each Charging Year
- Generator will have the option to submit their own forecast ALF by 31 October where they anticipate their load factor in the next charging year will be materially different from National Grid's forecast. National Grid will use this forecast in calculating TNUoS tariffs.
- Actual load factors will be calculated by National Grid by 31 May following the end of the charging year and compared to the generator's forecast (where submitted)
- Where the difference between actual and forecast is less than 2% (tolerance band) no further action shall be taken
- Where actual load factor exceeds the user's forecast by more than 2% the excess above 2% will be charged at 1.5 times the generator's applicable TNUoS charge
- Reconciliation payments will fall due for payment 20 Working Days after the date of invoice by National Grid
- As national Grid will have recovered its full Allowed Revenue through the actual tariffs levied during the charging year, there will be no cash-flow impact and any additional TNUoS revenue received from generators' reconciliation payments will effectively be an over-recovery.
- Any TNUoS over-recovery value will be returned to generators in proportion to their TEC value in the preceding charging year's charging model (i.e. on the same basis as the residual element of the TNUoS charge) within 90 working days of the end of the charging year.

The Workgroup Consultation document (sections 4.165 to 4.247) explores the various options for deriving an Annualised Load factor (ALF) for use in the charging methodology including a hybrid approach (s.4.211 to 4.214). This note outlines a possible process to apply such an approach above.

A backward-looking ALF calculation does not allow generators to inform National Grid of significant changes in their anticipated running regime due to circumstances which may be outwith their control such as catastrophic plant failure, or plant moving significantly out of merit due to moves in commodity prices.

While transmission investment is based upon longer term planning than year-ahead load factors, the receipt of information that a generator may change its running significantly will still be of material value to the system operator when planning system outages and when considering potential actions to mitigate constraints such as the need to enter into constraint management contracts.

Generators should be incentivised to submit an accurate estimate of ALF to ensure that the cost-reflectivity of TNUoS charges is maintained and a mechanism which recovers more than the cost had an accurate figure been originally submitted will achieve this. In the absence of a formalised overrun product as envisaged under CAP162, it is proposed to use a multiple of 1.5 times TNUoS as the charge for load factors in excess of forecast. As TNUoS tends to be higher in areas of higher constraint (reflecting the greater investment required) this will ensure an element of

cost reflectivity by charging a higher value where the generator's actions in exceeding its forecast ALF May have resulted in higher system operator costs. In areas where TNUoS tariffs are low, the impact of exceeding forecast TEC on system operator costs is likely to be correspondingly lower.

### **14.3 Remove 100% of the converter costs from the expansion factor**

- Onshore HVDC converter assets should be charged for under onshore charging methodology, and not offshore as intended by the Original Proposal.
- The full cost of the HVDC converter stations should be excluded from the expansion factor, providing a greater degree of stability and predictability to system users, and bringing charges in line with equivalent AC solutions considered.

The Workgroup has considered what proportion of HVDC converter station costs should be included in the HVDC expansion factor in the Workgroup Consultation Document (Section 5). Option (a)(i), is for the removal of all of the HVDC converter station costs on the basis that they should be treated as fixed. The locational element of ICRP charging is underpinned by a distance related methodology with fixed elements, such as transformers and compensation, being excluded from the calculation of the locational element of the tariff and instead being recovered through the residual element.

#### **1. HVDC Background**

HVDC is a new technology in UK onshore transmission and in the right application is able to offer significant benefits compared to traditional HVAC. HVDC converter stations have the same function as AC substations in that they transform power into a form suitable for long distance transmission. Two forms of HVDC conversion are available, traditional Current Source Converters (CSC) are to be used for the bootstraps, and newer Voltage Source Converters (VSC) are to be used for the island links. The converters are able to provide benefits to the networks to which they are connected. In particular VSC technology is able to provide dynamic voltage support to improve voltage and stability of the wider AC networks to which they are connected.

HVDC cables are generally much more efficient for longer distance transmissions than AC cables as AC must be rated for the capacitive charging current, in addition to active power transmission. The capacitance also causes voltage to increase along the cable length requiring mitigation through reactive compensation equipment. DC cables have no capacitive charging current so the full transmission capacity is available for active power. Ratings are therefore enhanced allowing smaller cables to be used, and losses are lower. DC circuits require only two conductors, there is no practical limit on cable length, and no intermediate reactive compensation stations would be required. As a result, DC cables can be undergrounded, or submerged, much more readily, reducing costs, consenting risk and timescales.

HVDC becomes economically attractive compared with traditional AC as the relatively high fixed costs of the HVDC converter stations are outweighed by the reduced cable and compensation requirements. It would be difficult, and costly, to provide acceptable alternative solutions for the bootstraps and island links based on AC technology, where significant technical problems would arise and significant consenting challenges would be foreseen.

## **2. Consideration of Charging**

The Original Proposal intends to treat the bootstraps and island links in the same manner as offshore, where connections generally service individual generating stations and solutions are developed and optimised by the connecting generator under OFTO arrangements. Offshore also benefits from a completely separate regulatory regime.

The bootstraps and island links are in fact extensions to the onshore transmission network, developed and optimised by the Transmission Owner in line with normal onshore network planning. Both will improve system security and will connect demand as well as multiple generators and technologies. As such any charging methodology adopted must be consistent with current onshore methodology. This is particularly important in the case of island links to ensure onshore island generators can compete on an equal footing with mainland renewable generation.

Under current onshore methodology, the costs of fixed assets such as substations and compensation equipment are recovered through the residual charge. HVDC converters are fixed assets comparable to AC substations in they transform power for long distance transmission, with the added benefit of capability to support the wider system and improved transmission capability.

## **3. TNUoS Analysis**

Two examples are considered to demonstrate why it would not be unreasonable to exclude the full converter costs from the expansion factor.

### **Example 1 – Western Bootstrap**

Whilst it is difficult to make a simple comparison between the proposed HVDC bootstrap and an equivalent traditional AC onshore solution it has been stated that, due to the number and scale of the works, the cost of onshore reinforcement would be similar to that of an offshore HVDC alternative.

We do know that the onshore solution would require significant works to a number of existing substations. It would also be likely that significant sections of the onshore route would be undergrounded limiting the overall rating, requiring additional compensation and increasing overall costs. AC cabling expansion factors exclude certain cost elements such as tunnelling, whereas the full costs of the DC cable installation would be included in the HVDC expansion factor.

Whilst additional work is required to determine an accurate comparison, it is evident that significant costs of the onshore solution would be excluded from the AC circuit expansion factor. The approximate cost of the HVDC converters is £300m of the total £1bn cost of the link. Excluding the HVDC converter costs from the bootstraps would therefore result in the order of 30% of the capital costs being removed from the HVDC circuit expansion factor. This should be quantified against the percentage of costs that would be removed from the equivalent AC onshore expansion factor, also recognising the improved visual amenity and reduced implementation timescales of the HVDC option.

### **Example 2 – Western Isles Link**

Building on the Western bootstrap example, a comparison has been undertaken of AC and HVDC solutions for the Western Isles Link. We know that SHETL considered both AC and HVDC options when developing the link, and have concluded that a 450MW HVDC link, incorporating VSC converter technology, as the optimum solution. Indeed AC solutions of the

same rating were found to be more expensive overall. For the comparison the same capital cost of £734m is assumed for both the HVDC and AC scenarios. Assumptions are also made for the apportionment of costs between the 80km subsea, 76km underground and converter/substation elements. 2013/14 TNUoS charging parameters have been used where available:

<b>HVDC Scenario</b> Capex split £200m converters (27%), £214m subsea (29%) and £320m underground (44%); annuity factor 5.81%	<b>Total TNUoS</b> <b>(Wider = £25.4/kW)</b>
<b>1 - full £734m capital costs included in expansion factor</b>	<b>120</b>
<b>2 - half convertor costs removed (£100m)</b>	<b>103</b>
<b>3 - all convertor costs removed (£200m)</b>	<b>86</b>
<b>AC Scenario</b> Capex split 35% subsea, 50% underground cables, 15% AC substation equipment; 275kV cable expansion factor = 11.45; expansion constant = 12.5; 275kV substation charge (no redundancy) = £0.097/kW; annuity factor 5.81%	<b>Total TNUoS</b> <b>(Wider = £25.4/kW)</b>
<b>1 - £734 capital costs, full subsea costs included in EF, generic factors applied for underground and substations</b>	<b>80</b>

Whilst more detail from SHE Transmission would be helpful, it would appear that removing the full cost of the HVDC converter stations would not seem unreasonable under a consistent onshore charging regime.

Consideration could also be given to capping the DC cable expansion factor at the equivalent generic AC cable expansion factor. As the capital costs of the installed DC cables will be lower than AC cables, it would seem appropriate for the locational element of the DC cable charge to be no more than that determined from the equivalent AC expansion factor.

#### **4. Conclusions**

The use of HVDC technology has been selected as the most economic and efficient solution for the bootstraps and island links. The proposed links will be developments of the onshore transmission network, as such any charging methodology adopted must be consistent with that of onshore. This is essential to ensure that onshore generators in all parts of the UK can compete on an equal footing.

It would seem appropriate for the full cost of the converters to be excluded from specific HVDC circuit expansion factors, treating the HVDC fixed assets in exactly the same way as AC fixed assets, whilst also recognising the benefits of the new HVDC technology. This would lead to more consistent charging between the two technology solutions and provide a greater degree of stability and predictability to system users.

It would seem unreasonable, and probably discriminatory, to burden onshore generators connected by HVDC circuits with a higher transmission charge as a result of employing a superior technology type on the grounds of transmission system economy, performance and environmental impact.



#### 14.4 Use of generic percentages for the exclusion of the HVDC converter station costs

- Generic percentages should be developed to improve predictability and stability
- Separate percentages should be derived for current source (CSC) and voltage source (VSC) HVDC converters to improve cost reflectivity

The Work Group has considered what proportion of HVDC converter station costs should be included in the Expansion Factor for HVDC costs in the Work Group Consultation Document (Section 5). In particular, there has been an examination of option (a) (ii), the removal of a percentage of HVDC converter station costs based on elements within the converter station which perform a similar function to elements used on the AC transmission network (Consultation Document 5.30 to 5.45).

While it is accepted that there should be specific Expansion Factors for each HVDC circuit due to their varying lengths and therefore the differing proportion of cost split between the HVDC cable and the associated converter stations, it would provide a greater degree of stability and predictability to system users if the percentage of converter station costs to be included in the expansion factor was codified in advance.

Two types of converter can be used, Current Source Converters (CSC) and Voltage Source Converters (VSC). Based upon the analysis of the 2001 Cigre paper (186) a case has been made for the exclusion of 50% of the costs of a typical converter station as these elements perform a similar function to those of AC transmission substations (sections 5.32 to 5.35 of the Workgroup report). This conclusion remains consistent with the updated 2009 Cigre paper (388) and also the 2012 PB Power Electricity Transmission Costing Study which reference the same cost breakdown.

Detailed converter cost information has also been sought from technology suppliers. However, concerns were expressed on the confidential nature of such detailed costing information. This level of detail has not been in the public domain previously as converters have been supplied under turnkey contracting arrangements as part of larger transmission projects. A leading supplier has, however, confirmed that the Cigre cost breakdown is representative of the AC/DC equipment in both CSC and VSC technologies.

A robust case does therefore exist for the exclusion of 50% of the converter station costs for both CSC and VSC technologies.

In addition, (sections 5.36 to 5.44) the case has been made for exclusion of a further 10% of CSC costs on the grounds that some of the HVDC components provide functions identical to Quadrature Boosters (QBs) on the AC system which are socialised under the current charging methodology.

To provide consistency of treatment and avoid discrimination **both** the substation and QB elements should be excluded when calculating the proportion of converter station costs included in the calculation of circuit specific HVDC expansion factors.

The recent paper entitled HVDC – The Benefits of Voltage Source Converters (VSC), submitted in response to Workgroup action 97, highlighted that VSC technology in particular is able to offer additional

system benefits, evidenced by input from SHE-Transmission and the Western Isles Link project case study. Other sources such as the PB Power paper reinforce this stating that VSC technology can offer distinct and unique advantages to the wider transmission system.

The case has been made for exclusion of a further 20% of VSC costs on the grounds that the converters provide functions identical to static compensators (STATCOMs) on the AC system which are socialised under the current charging methodology. This is based on costing information in the 2011 National Grid Offshore Development Information Statement (ODIS).

It would therefore be appropriate when developing generic percentage cost exclusions for HVDC converter stations that separate percentages are applied for CSC and VSC technologies in order to maintain cost reflectivity, as follows:

#### CSC technology

- a generic 50% is excluded in respect of substation equipment
- a further exclusion of up to 10% to account for QB functionality

#### VSC technology

- a generic 50% is excluded in respect of substation equipment
- a further exclusion of up to 20% to account for STATCOM functionality

## 14.5 Removing specific AC equivalent costs

CMP213 issue 49 explored the reasons as to why specific expansion factors are calculated for offshore transmission assets, in comparison to onshore network where they tend to be generic. These could be summarised as:

- There is insufficient information on which to create a generic forward looking factor; and
- The costs of different offshore networks are sufficiently different to justify a specific approach.

Options put forward for the removal of some or all costs of converter stations from HVDC links have focussed on generic approaches based on the limited amounts of historic actual numbers available. For instance, the approach for removal of 50% of costs is based on a single set of figures referenced in table 18 of the workgroup consultation.

In order to avoid accusations of discrimination, it is important that the methodology should be consistent in its approach unless otherwise justified. Such justification should demonstrate that circumstances are relevantly different to warrant different treatment. On a technical and financial basis, the original assumes HVDC links are similar to offshore transmission networks.

The costs of HVDC solutions are expected to be significantly different from each other and indeed are expected to utilise very different technological solutions. Also, there isn't a large amount of data available with which to create a forward looking generic factor. This implies that a specific approach should similarly be adopted for HVDC assets.

Therefore, a more appropriate approach to calculating the expansion factor for converter stations would be to remove the specific costs that would be equivalent to an AC substation on a case by case basis, rather than relying on a generic proportion. Such a calculation would be carried out at the same time as other parameters such as the expansion constant to ensure that relative costs are still reflected in the methodology.

The key benefits of this approach are that it is cost reflective and avoids concerns regarding undue discrimination.

## 14.6 HVDC –The Benefits of Voltage Source Converters (VSC)

### 1. Introduction

This paper outlines the benefits for AC networks from the operation of HVDC converters utilising VSC converter technology. The capability of VSC is summarised considering benefits for both the local and wider network. A case study for Western Isles Link is provided to outline how these benefits will apply in a real project situation.

Input has been sought from Scottish Hydro Electric (SHE) Transmission in the preparation of the benefits sections, in particular for the case study on the Western Isles Link, and technical information has been provided by ABB.

### 2. Background and Summary of Benefits

VSC based systems use insulated-gate bipolar transistor valves which are more controllable than conventional thyristor based current source converters (CSC). The VSC device is self-commutating meaning the converter is not dependent on the AC system voltage for its correct operation.

In the correct circumstances installation of HVDC VSC based links can be beneficial to overall transmission system performance, this applies to radial island links. VSC technology can rapidly control both active and reactive power independently of one another. Reactive power can also be controlled at each terminal independent of the DC transmission voltage. Self-commutation with VSC can provide black start capability, and the dynamic support of the AC voltage at each converter terminal improves the voltage stability and can increase the transfer capability of the connected AC systems. There is no restriction on minimum network short-circuit capacity meaning converters can operate in remote locations.

The benefits are outlined in more detail in Appendix 1.

### 3. Case Study - Western Isles Link

*Based on information provided by SHE Transmission.*

**Requirement:** To provide 450 MW of transmission export capacity for renewable generation in the Western Isles into the main interconnected transmission system (MITS) on the Scottish mainland.

**Solution:**

- 450MW HVDC link with converter stations on the mainland at Beauly and Gravir on the Isle of Lewis.
- The link will operate at 150kV with a modified monopole topology using multi-level VSC converters.
- The route is 156 km in length with 80km of subsea cable and 76km of land cable sections.

**Summary and benefits:**

The Western Isles possesses attractive renewable resources which have stimulated developer interest in developing generation projects. Based on formal applications, enquiries and an understanding of developer scoping activities, the potential capacity that could seek to connect is thought to be in the region of

900MW. It was decided that the HVDC should be progressed in a phased approach by installing a 450MW link first followed by a second at a later date when required.

In developing the Western Isles Link SHE Transmission assessed both HVAC and HVDC alternatives, considering available technology, cost, environmental impact and consenting risk. A 450MW HVDC link, based on VSC converter technology, provided the best overall solution when compared against a range of alternatives.

HVDC overcomes the inherent technical problems of long lengths of HVAC cable in the system enabling long distance transmission by underground cable with low losses. This has permitted the full 156 km to be installed as cable, of which 80 km is subsea and 76 km underground. The inherent reactive power capability of VSC converters will provide rapid continuous control of reactive power at both ends of the link without the need for external reactive compensation equipment.

The flexibility provided by VSC converters will provide system benefits at both Beaulieu and also on the Western Isles:

- As the transmission system develops in northern Scotland voltage support becomes a key requirement at critical points on the network. Beaulieu is a key hub on the system, particularly once the Beaulieu-Denny 400kV overhead line has been constructed. The reactive capability of the Western Isles Beaulieu converter will be used along with other reactive compensation devices in the area to maintain system voltage at optimum levels and should have a positive impact on system stability. The reactive capability of the converter will provide the system operator with more flexibility in managing voltage profiles within the surrounding network and providing a greater degree of redundancy in the provision of reactive support.
- On the Western Isles, the Graving converter will provide the necessary voltage support and dynamic stability for the large wind farms on the island. The interaction with the various renewable generators will need to be planned carefully, but overall it is expected that network security and quality of supply for the island will be improved following the installation of the Western Isles Link.
- The black start capability of VSC converters will benefit the island following outages, restoring supplies without the need to start up standby diesel generation.

#### **4. Benefits Conclusion**

VSC based HVDC technology can in the right circumstances offer significant benefits over traditional HVAC transmission. For the proposed Western Isles Link, all options were assessed taking into account technical, economic and environmental factors and a VSC based HVDC solution was concluded to offer the optimum solution.

VSC converter stations not only enable efficient long distance power transmission, but also provide very controllable reactive compensation capability which will benefit both the embedded network to which it is connected and the quality of supplies at the remote end. In some circumstances such as the Western Isles it would be very difficult, and costly, to provide an acceptable alternative solution based on HVAC technology, where significant technical problems arise and

substantial compensation equipment would be required to comply with the necessary supply standards.

Where power export levels are high and distances are long, such as island links, HVDC based on VSC converters offers best available technology. For these applications VSC HVDC performs in a more effective way than AC, with significant additional benefit to the system, and with less environmental impact.

## **5. Consideration of Charging**

The use of HVDC technology has been selected as the most economic and efficient solution for the island connections, as demonstrated by the Western Isles Link. The sophisticated controllability of the HVDC converters will bring wider benefits to the networks to which they are connected.

The island links are developments of the onshore transmission network, as such any charging methodology adopted for the island links must be consistent with onshore methodology to ensure that island generators can compete on an equal footing with mainland renewable generation.

Under current onshore methodology, the costs of fixed assets such as substations are recovered through the residual charge. This also applies to voltage compensation equipment. HVDC converters are fixed assets comparable to AC substations, the converters comprise both AC and DC equipment, with the DC capability of the VSC converter able to provide sophisticated dynamic voltage compensation. This would support the case to recover more, if not all of the converter costs through the residual.

Moreover, removing the full converter costs is likely to bring the resulting HVDC TNUoS in line with the level that would have been applied had an AC solution been implemented. Analysis is being undertaken to demonstrate this point.

### References:

1. *SHE Transmission report "Western Isles Link – The upgrade of grid access on the Western Isles", June 2012*
2. *ABB VSC technical paper "It's Time to Connect", April 2010*
3. *ABB HVDC technical paper "The ABCs of HVDC Transmission Technologies", April 2007*
4. *National Grid factsheet "High Voltage Direct Current electricity – technical information", June 2010*
5. *PB Power "Transmission Investment Project Appraisal Report", January 2010*
6. *TNEI Report "Assessment of transmission investment funding request for the Western Isles link and Lewis Infrastructure projects", November 2010*

## Appendix 1 – benefits for AC networks arising from VSC converter

### operation:

- **Independent active and reactive power control**, VSC technology allows independent and rapid control of both active and reactive power, with control of its working point almost instantaneous. This can be used to support the grid with the optimum mixture of active and reactive power, offering more control than either active or reactive power control only.
- **Active power** flow can be determined either by means of an active power order or by means of frequency control. The converter stations can be set to generate **reactive power** through an active power order, or to maintain a desired voltage level in the connected AC network. As a result, in an AC network, the voltage at a certain point can be increased or reduced through the generation or consumption of reactive power by the converter, and AC voltage can be controlled independently in each station.
- **AC network stability**, the level of controllability offered can provide potential to improve AC network stability by providing fast and accurate active control of reactive power and voltage support for the connected AC networks. VSC converters can operate down to zero power allowing the full range of reactive power to be utilised.
- **Improved system voltage**, the controllability can also be used to allow operation of the connected AC networks closer to its maximum permitted voltage to reduce the line losses in the connected network. The higher voltage level would allow more power to be transferred through the AC lines without exceeding the current limits. Transient over-voltages would be counteracted by the rapid reactive power response.
- In **remote locations**, VSC converters are able to operate without any other voltage source. The VSC converter would be able to maintain AC voltage and frequency within required limits irrespective of whether the connected AC network is sufficient for the connected load. The fast reactive power control properties of VSC converters can also be used for flicker mitigation, and eliminate selected harmonics in the AC network.
- **Short circuit power levels**, it is possible to operate at low short-circuit power levels, a key benefit for connecting large amounts of wind power to transmission networks, even at weak points in a network, and without having to improve the short-circuit ratio. This compares to AC transmission systems, which normally require a high SCR compared with the power to be entered. With more wind capacity on the system it is important that plant stays on line through system faults. To achieve this in an AC network various types of compensation would be required to preserve quality and stabilise the network. VSC does not require any additional compensation, as this is inherent in the converters, and allowing improved fault ride through capability for the connected generation.
- **Voltage compensation**, VSC converters can be operated as a STATCOM, even if the converter is not connected to the DC line, which would allow active voltage stabilisation in advance of the DC circuit being commissioned.
- **Black start capability**, VSC converters can offer black start capability. A VSC transmission system can control voltage and stabilize frequency when active power is available at the remote end. The frequency control is then not limited in the same way as a conventional power plant where, for example, thermal dynamics may limit the operation during grid restoration.
- **Reversible power flows**, continuously variable power from full power in one direction to full power in reverse is possible. This means that an active

power transfer can be quickly reversed without any change of control mode, and without any filter switching or converter blocking. The power reversal is obtained by changing the direction of the DC current and not by changing the polarity of the DC voltage as for conventional HVDC. The speed of the reversal is determined by the network, the converter could reverse to full power in milliseconds if needed. The reactive power controller operates simultaneously and independently in order to keep the ordered reactive power exchange unaffected during the power reversal.



## 14.7 Pseudo AC approach

The Original proposal states that the full costs of HVDC converter stations should be included in the circuit expansion factor for the HVDC bootstraps, and for Island connections utilising this technology. This is different from the treatment of AC substations, which are excluded from the circuit expansion factors. Several consultation responses highlighted that this classification of costs will result in significantly different TNUoS charges, which for the HVDC bootstraps means that certain generators' charges are significantly higher than if an AC solution of similar capex size could be found. These responses highlighted that it was inappropriate that the TO's technology choice should have such an effect on users' charges when the total capex of the reinforcement is similar between technologies. Similarly, the same apportioning of costs as in the original for HVDC bootstraps and Island connections already applies to offshore connections. Where offshore developers using generator build have a choice between HVDC and AC solutions, the TNUoS implications of the DC option makes it significantly less likely to be chosen, even when the total capex of the two options are similar.

As a 'pseudo-AC' approach has been proposed for the modelling treatment of the flows associated with the HVDC circuits, a consistent approach would be to also apply a pseudo-AC approach to the calculation of the expansion factor.

This alternative proposal is to treat HVDC costs in a similar manner to AC costs, by apportioning the costs associated with the technology to circuit and residual elements in the same proportion as occurs on the AC system.

**(fixed costs on AC RAV/total AC RAV) = % of HVDC costs socialised**

This is a simpler approach than the potential alternative which looks at splitting the HVDC converter station into its AC and DC elements, does not rely on potentially commercial information about the design of converter stations, can be applied consistently to bootstraps, island connections, and offshore connections, and should remain relatively stable over time.

## 14.8 Treatment of HVDC bootstrap cost as onshore AC transmission technology cost when calculating the expansion factor

This paper sets out the proposed alternative way of treating HVDC 'bootstraps' (that parallel onshore AC transmission circuits) namely to treat them in relation to the equivalent onshore 400kV AC transmission.

The attached Annex provides extracts from a number of supporting sources including:-

- i) The CMP213 Workgroup Consultation Document;
- ii) The SSE response to the CMP213 Consultation;
- iii) and iv) The Western Link website; and
- v) The CMP213 Proposal.

### Discrepancy with the Original and proposed alternative

The current status quo (or 'baseline') ICRP model combines MWkm figures with £/MW expansion factors to allocate a cost to each electrical transmission circuit. The transport methodology used by National Grid is based on:

- The use of generic transmission system investment cost information; and
- Reinforcement takes place on existing routes using the route specific technologies.

This is based on the principle that the cost of accommodating initial generation/demand is best represented as the electrically weighted average cost of expanding all the existing paths between nodes.

Inclusion of the HVDC bootstraps into this methodology is problematic for a number of reasons:

- a) It assumes that incremental capacity increases would be made to HVDC bootstraps in the same fashion as onshore pathways. This is clearly not the case as evidenced by the nature of the specific investment case made for the HVDC bootstraps.
- b) It ignores the fact that the bootstrap investment is not made on cost grounds alone and thus underplays the societal value of the bootstraps,

The consequence of including the bootstraps within the current methodology is that a significantly greater incremental cost is allocated to generation "upstream" of the bootstraps.

If the HVDC bootstrap(s) had not been put in place under the Connect & Manage regime the consequence of additional generation in the north of GB would have manifested itself in the form of expansion of the (onshore) transmission circuits connecting Scotland with England and Wales using the MWkm of those circuits and their generic cost as 400 kV or 275 kV lines (as appropriate).

This represents the counterfactual for the investment cost impact of the Western (and Eastern) HVDC bootstrap link(s).

The Western HVDC bootstrap has been sanctioned, by Ofgem, on the basis that it represents better value for GB customers than the alternative (onshore) overhead AC solution.

It is anticipated that this will also be the case with the Eastern HVDC bootstrap – on the basis that if it were not the most economic and efficient solution it would not be approved by Ofgem.

However, using an expansion factor based on HVDC bootstrap costs, would result in an elemental cost 20 or more times that of an overhead line. This is many times greater than that for the counterfactual.

Given this it does not follow that the HVDC bootstraps should be treated in the Transport model as currently proposed by CMP213.

The use of HVDC specific costs does not reflect the investment analysis by the TOs that has led to the decision by Ofgem to go ahead with the most economic and efficient solution, namely the HVDC bootstraps, compared with the (onshore) AC parallel circuit(s) and is therefore not “cost reflective”.

This proposed alternative assumes that the counterfactual is the cost of the alternative transmission investment.

Thus each HVDC bootstrap would be treated as if it were a 400kV OHL of an equivalent MWkm rating based on the equivalent capacity that had been modelled by the TO(s).

Therefore, rather than adding an HVDC element in terms of MWkm and HVDC specific expansion factor, the Transport model would, under this proposed alternative, have an HVDC proxy element added based on the equivalent (onshore) AC capacity.

An alternative option would take account of the claimed fact that the alternative onshore investment to the HVDC Bootstraps would have a higher electrical capacity. (that is in effect available “free” compared to the HVDC Bootstraps.) If it is the case that the onshore capacity is indeed higher than the expansion factor applied to the HVDC link can be scaled up taking account of the ratio of the counterfactual onshore and the HVDC link. (table follows)

At the Workgroup meetings on 5<sup>th</sup>-6<sup>th</sup> February 2013 National Grid advised the Workgroup that the equivalent capacity of the alternative (onshore) AC transmission circuit that had been modelled by the two respective TOs when considering which was the most economic and efficient solution was 3.4GW.

From the public statements of the TOs and Ofgem (see footnotes 3 & 4 in the Annex) we know that the cost of the Western HVDC (at ~£1,051M) was similar (or less) to the equivalent (onshore) AC transmission circuit(s) modelled by the TOs.

Given that the costs of both the onshore option and the offshore option are similar at ~£1,051M then the only additional variable is the equivalent capacity associated with each option.

Thus if the onshore capacity is 3.4GW and the offshore is 2.2GW we can deduce that as the onshore capacity has an expansion factor of 1.00 then

the offshore capacity would have an expansion factor of 1.55 and this can be scaled for other levels of onshore capacities.

This is illustrated in Table 1 below (table 2 provides further information on the options shown).

**Table 1**

<i>Option</i>	Onshore Capacity (GW)	Expansion Factor (bold) for HVDC capacity (2.2GW)						
A	equal	<i>1.00</i>						
B	2.2	<b>1.00</b>	<b>1.55</b>	<b>2.00</b>	<b>3.00</b>	<b>3.09</b>	<b>4.00</b>	<b>10.00</b>
C	3.4		<i>1.00</i>					
D	4.4			<i>1.00</i>				
E	6.6				<i>1.00</i>			
F	6.8					<i>1.00</i>		
G	8.8						<i>1.00</i>	
H	22.0							<i>1.00</i>

**Table 2**

<i>Option</i>	Cost	Capacity (GW)	Notes
A (&B)	~£1,051M	2.2	Capacity of the Western HVDC link
C		3.4	Onshore capacity modelled by TOs
D		4.4	Onshore twice the option A capacity
E		6.6	Onshore three times the option A capacity
F		6.8	Onshore twice the option C capacity
G		8.8	Onshore four times the option A capacity
H		22.0	Onshore ten times the option A capacity

## Annex

### (i) Extract from CMP213 Workgroup Consultation Document: pages 110-111

#### Workgroup potential alternative (a) (iii)

- 5.46 Some of the Workgroup believed that the expansion factor calculation for HVDC transmission circuits should be based on actual HVDC unit costs in order to be cost reflective.
- 5.47 One Workgroup member cited several public documents setting out the cost of the Western HVDC 'bootstrap' transmission circuit:
- 1) the joint statement from National Grid and Scottish Power in July 2012 concerning the Western HVDC 'bootstrap' and, in particular, the statement "...that the cost of onshore reinforcement would be similar to that of an offshore HVDC alternative" *[footnote 3 below]* ; and
  - 2) the joint DECC / Ofgem ENSG report 'Our Electricity Transmission Network: A Vision For 2020' (February 2012) and, in particular, that the onshore circuits "...did not represent the most economic solution. The total length of the new circuits would be in excess of 600km; this resulted in a total project cost that was higher than the undersea HVDC option." *[footnote 4 below]*
- 5.48 Some of the Workgroup believed, in the case of the Western HVDC link, that it should be treated in exactly the same way as the equivalent parallel (onshore) AC 400kV transmission circuits in the TNUoS charging methodology.
- 5.49 It was appreciated by the Workgroup that this approach would apply the existing expansion constant (i.e. an expansion factor of 1) to the HVDC transmission circuit, and that this would ultimately result in a reduction in tariffs in TNUoS zones north of the HVDC transmission circuit.
- 5.50 These Workgroup members believed that to do otherwise would be to unduly discriminate against certain Users as they would be exposed to a higher TNUoS charge, even though the actual cost and MW capacity of the two comparable links (one 400kV AC onshore / one 600kV HVDC offshore) were similar. These members considered that in addition to being discriminatory it would also not be cost reflective given that both the cost and capacity were similar, but one option (the onshore AC) would, if built, have resulted in a substantially lower TNUoS charge than the other option (subsea HVDC).
- 5.51 The Workgroup discussed the differences between a sub-sea HVDC transmission link and the alternative (onshore) 400kV AC transmission reinforcements in terms of capacity provided, costs and timescales. Not all members of the Workgroup were convinced that both cost and network capacity provided by the onshore AC and sub-sea HVDC options were comparable.

- 5.52 One significant difference identified by some Workgroup members was the significant annual constraint costs that would be incurred during the planning delays expected to occur during the building of the aforementioned onshore alternative transmission system reinforcement.
- 5.53 In particular, based on recent experience with long distance onshore 400kV overhead transmission line construction, it is generally anticipated that building an equivalent onshore transmission link could take more than 10 years, from concept to commissioning. This was likely to be halved for an equivalent HVDC transmission link, leading to a period of time where such an HVDC link provided relief, from constraint costs, compared to the equivalent onshore link. In the view of some Workgroup members this should result in a discount, on the HVDC TNUoS charge, to reflect the constraint costs saved (over the period of time in question). However, other members of the Workgroup noted that constraint costs were not charged locationally.
- 5.54 A potential alternative where a sub-sea HVDC transmission circuit is treated as if it were (onshore) 400 kV transmission technology was deemed plausible by some members of the Workgroup., but was not widely supported by Workgroup members.

**(ii) Extract from CMP213 Workgroup Consultation Response: SSE Q6 pages 7-9**

However, we believe that the Workgroup has to fully recognise that the treatment of the only HVDC link under construction (which parallels the onshore AC network) within the charging methodology should reflect the fact that as the cost of both the onshore and offshore links are similar (or less) that the eventual charges should also be similar (or less) depending on the capacity of the onshore link.

In the absence of evidence from the TOs (or Ofgem) to the contrary we believe the capacity figure for both links are similar (at ~2.2GW) and therefore the effect on TNUoS tariffs should also be similar. It would, for example, be very odd for the two TOs concerned to have modelled a significantly greater onshore capacity for the onshore link (compared with offshore) as this would seem to undermine both their public statements (and those of Ofgem / DECC).

In coming to this view we have noted, in particular, the deliberations set out in paragraphs 5.46-5.54. Given that the published cost of the Western HVDC is in the order to £1,051M<sup>37</sup> and the capacity is in the order of 2.2GW<sup>38</sup> and that, according to the two respective TOs, the cost is similar<sup>39</sup>

---

<sup>37</sup> Ofgem 27th July 2012

[http://www.ofgem.gov.uk/Networks/Trans/ElecTransPolicy/CriticalInvestments/InvestmentIncentives/Documents1/Jul12\\_WHVDC\\_decision\\_FINAL.pdf](http://www.ofgem.gov.uk/Networks/Trans/ElecTransPolicy/CriticalInvestments/InvestmentIncentives/Documents1/Jul12_WHVDC_decision_FINAL.pdf)

<sup>38</sup> Ofgem 21st May 2012

[http://www.ofgem.gov.uk/Networks/Trans/ElecTransPolicy/CriticalInvestments/InvestmentIncentives/Documents1/TII\\_May12\\_WHVDC\\_consultation.pdf](http://www.ofgem.gov.uk/Networks/Trans/ElecTransPolicy/CriticalInvestments/InvestmentIncentives/Documents1/TII_May12_WHVDC_consultation.pdf)

to the parallel (onshore) AC 400kV circuits (and according to the regulatory bodies the cost, of going offshore, is less<sup>40</sup> than onshore) we would expect the cost, in terms of TNUoS tariffs, to also be similar (or indeed, based on the regulatory analysis, less) between the offshore cable and the onshore route.

In other word, for illustration purposes only, if the effect of building the onshore capacity was £1 (in terms of TNUoS tariff increases for those Users north of the B6 boundary) then the effect of providing that capacity via the offshore Western HVDC should be similar at £1; i.e. it might, say, be £0.95p or £1.05p depending on what the actual costs (as shown in the TOs CBA provided to Ofgem) was.

---

<sup>39</sup> Joint SPTL/NGET Planning Statement Western Link (July 2012) paragraph 2.5.2.

3 Joint SPTL/NGET Planning Statement Western Link (July 2012) paragraph 2.5.2.

**“Analysis of the existing onshore system showed that the volume of additional capacity required could only be provided through the construction of new transmissions circuits and upgrading of certain existing circuits. Due to the number and scale of these works it was concluded, in this particular case, that the cost of onshore reinforcement would be similar to that of an offshore HVDC.”** *[emphasis added]*

<sup>40</sup> Joint DECC / Ofgem ENSG report ‘Our Electricity Transmission Network: A Vision For 2020’ (February 2012) [page 70]

“A number of alternative onshore solutions were considered to increase the boundary capability of the B6, B7 and B7a boundaries. These included:

**A number of projects have already been planned to ensure that the maximum capability (4.4GW) of the existing circuits can be realised. Further reinforcement would be required in the form of either two new 400kV transmission circuits: one from the West of Scotland to Lancashire and one from the East of Scotland to North East England or reconductoring existing 400KV double circuit between Harker and Strathaven and additional series compensation in these circuits to provide the necessary boundary capacity. These options were discounted for three main reasons:**

**(a) They did not represent the most economic solution. The total length of the new circuits would be in excess of 600km; this resulted in a total project cost that was higher than the undersea HVDC option.** *[emphasis added]*

(b) The construction of new onshore overhead line routes would have a greater disruption to land and higher visual impact.

**(c) The timescales required to progress a project through the planning and consents process as prescribed in Appendix F would result in higher constraint costs.**

**For these reasons it was decided not to progress with onshore AC reinforcements.”** *[emphasis added]*

This is what any neutral observer would expect – the cost of the link is similar, the capacity is similar therefore, if the TNUoS charges are to be cost reflective then they too should be similar.

However, we note that it has been difficult to source what, approximately, is the capacity of the onshore parallel AC circuits that have been modelled / assessed by the two TOs involved in this project (and by Ofgem / DECC).

Clearly with the cost being similar (according to the TOs - or less according to Ofgem / DECC) at £1,050M if, therefore, the onshore capacity modelled was twice that of the Western HVDC at, say, circa 4.4GW then, in terms of the illustrative example used here, the effect on TNUoS tariffs (for those Users north of the B6 boundary), should be twice that of the equivalent parallel onshore network; i.e. in the order of £2 for going offshore compared with £1 for the equivalent onshore.

However, if for example the effect on TNUoS tariffs (for those Users north of the B6 boundary) of going offshore was 10 or 20 times greater then this clearly implies that the parallel onshore AC circuit capacity that was modelled by the two TOs (and reviewed by Ofgem / DECC) would be 10 times; i.e. 22.2GW; or 20 times (44.4GW) greater. This is because as the cost remains similar (or less) the only other variable, in terms of cost reflectivity, is the capacity to be built.

Only in this way could it be said that the TNUoS tariffs for Users north of B6 are cost reflective, with respect to the effect of building (and charging for) the Western HVDC link.

Our understanding is that the capacity of the onshore route is neither 10 nor 20 times that of the offshore cable and therefore cannot reconcile why the offshore cable should be so much higher (in terms of TNUoS charge) than the onshore route. That being the case, we believe that this aspect needs reconsidered by the Workgroup.

### **(iii) Extract from Western Link website<sup>41</sup> as at 10<sup>th</sup> February 2013**

#### **The project**

The Western Link will bring renewable energy from Scotland to homes and businesses in England and Wales.

In the UK electricity is normally generated, transmitted, distributed and consumed as alternating current (AC). Direct current (DC) is not so widely used and to date has been applied in a small number of projects.

The Western Link will use DC technology to reinforce the existing UK transmission system and move electricity across the country in very large volumes.

In addition to installing a new high voltage connection, we need to convert the DC electricity to AC at each end of the link so that it can be used within the existing electricity transmission system. To do this we need to build a converter station at each end of the link.

**We need to transfer around 2,000MW of power across several hundred kilometres to link the transmission network in Scotland with that in England and Wales, and a subsea marine HVDC cable is the best method of doing this because: *[emphasis added]***

- **It provides the most efficient and economic solution (in many cases the use of HVDC technology is relatively expensive and not efficient) *[emphasis added]***

---

<sup>41</sup> <http://www.westernhvdclink.co.uk/the-project.aspx>



- **DC circuits can transmit power more efficiently over long distances, on fewer cables than equivalent AC circuits** [*emphasis added*]
- The use of DC transmission makes long-distance subsea cable technically possible
- Subsea cables can be installed relatively quickly, with minimal disruption to local communities

Whilst electrical power is often expected to flow from north to south, the Western Link will be bi-directional in that power can also be made to flow in the opposite direction according to future electricity supply and demand requirements

**(iv) Extract from Western Link website<sup>42</sup> as at 10<sup>th</sup> February 2013**

Q&A

Answers to some of the key questions raised over the course of the project.

Why use a high voltage direct current cable?

We need to transfer around 2,000MW of power across several hundred kilometres to link the transmission network in Scotland with that in England and Wales, and a subsea marine HVDC cable is the best method of doing this because:

- It provides the most efficient and economic solution (in many cases the use of HVDC technology is relatively expensive and not efficient)
- DC circuits can transmit power more efficiently over long distances, on fewer cables than equivalent AC circuits
- The use of DC transmission makes long-distance subsea cable technically possible
- Subsea cables can be installed relatively quickly, with minimal disruption to local communities

Why is a subsea cable the preferred option?

**We selected a subsea cable from a number of options that we considered, including overhead lines and underground cables across mainland Britain. Taking into account the overall costs, potential impacts on local communities and potential environmental effects, we believe a subsea cable is the most appropriate solution.** [*emphasis added*]

**(v) Extract from CMP213 Proposal<sup>43</sup>: page 4**

*b) Expansion Factor*

The charging methodology incorporates the unit cost of various transmission technologies by calculating the cost of a given technology relative to the cost of 400kV overhead line. This allows for the calculation of a multiplier, known as an expansion factor, which is used in the

---

<sup>42</sup> <http://www.westernhvdclink.co.uk/qanda.aspx>

<sup>43</sup>

<http://www.nationalgrid.com/uk/Electricity/Codes/systemcode/amendments/currentamendmentproposals/>

Transport model to calculate the locational signal within TNUoS charges. As HVDC technology does not currently exist in the Transport model, a method of incorporating its unit cost is also required.

This proposal would introduce a new expansion factor for each HVDC circuit depending on its voltage. In addition, as HVDC converters are an integral element of the distance related locational signal of the link, it is proposed to include the cost of these converters into the expansion factor calculation for each circuit. Currently HVDC converters can be broadly split into two different types, current source converters and voltage source converters, leading to the potential for two additional expansion factor types. Where a different approach is developed through the working group process that is reasonably considered by the proposer to better meet the miscellaneous terms set out in the Authority's direction, it shall be substituted into this proposal in accordance with the proposer's rights under clauses 8.16.10 and 8.20.23 of the CUSC. It is recognised that stand-alone alternatives may also be developed through the working group process.

## 14.9 Setting expansion factors at T-4

The Working Group has reached some consensus that parallel HVDC and island connections are, at the moment, relatively bespoke reinforcements. There is also limited historical experience from which to extrapolate costs. This makes it difficult to average costs across recent and historical projects to derive a generic expansion factor. Even if costs were estimated, there would be big winners and losers in averaging over such a wide range of asset sizes, lengths and costs

The Original proposes that expansion factors are set only when the actual costs of each link are known i.e. just before the project connects. Whilst this overcomes the need to estimate or average costs and does provide charge stability post-connection, it introduces significant pre-connection uncertainty in charges. This in turn makes it difficult to commit to a project and underwrite the grid connection, sterilising development relying on these connections. Recent experience in the Western Isles where there has been a 60% increase in estimated costs serves to emphasise this. This is particularly difficult to manage after developers have placed user commitment, secured finance and moved into the construction phase of projects.

In order to bring some stability back into asset-specific expansion factors, the proposal is to estimate and fix the expansion factor at T-4, in line with placing wider user commitment which in turn is in line with the TO's commitment to grid infrastructure. The fix would include the costs of physical assets, and factor in sharing factors and fixed cost deductions agreed elsewhere in the Modification. It would also include a proportion of the estimated installation costs.

Cost increases would be absorbed by the charging base if deemed efficient, and by the TO if deemed inefficient. Cost decreases would be shared by the charging base.

## **14.10 Briefing Note for 7<sup>th</sup> August 2012 meeting on HVDC removal of convertor station costs**

This note suggests that HVDC convertor station costs should be treated as fixed costs and recharged through the Residual element of the TNUoS tariff.

The locational element of the ICRP methodology is underpinned by a MWkm (distance related) methodology. Fixed elements such as transformers are excluded from the calculation of the locational element of the tariff and instead appear in the Residual element. HVDC convertor stations exhibit the same traits as other fixed elements of the transmission system. For example, they have broadly the same function as transformers/substations in that they effectively link different elements of the transmission system and they can provide system services (specifically reactive compensation and post-fault power flow redirection).

Including any fixed costs in the calculation of expansion factors will cause a distortion in the locational element of the tariff. This is particularly the case with HVDC cables as the convertor station costs are such a significant proportion of the cost. Including fixed costs in the calculation of the HVDC cable expansion factor will cause a distortion in the locational element of the tariff and would make it inconsistent with the existing methodology expansion factors calculations. For example, using the example in the Working Group Report and taking the cable cost as including the convertor station costs. The cost is £1bn, the capacity 2GW and the distance 370km. The cost of the convertor stations is £550m. In a distance related model, it would be expected that if the distance halved, the effective cost of the cable would reduce in proportion. However, including the convertor costs means that when the cable length is halved, the effective cost in £/MWkm in the model would increase by 55%. This cannot be a proper reflection of the locational element of the costs. That can only be reflected by excluding the costs of the convertor stations from the calculation of the cable expansion factor and allocating the convertor station costs to the Residual.

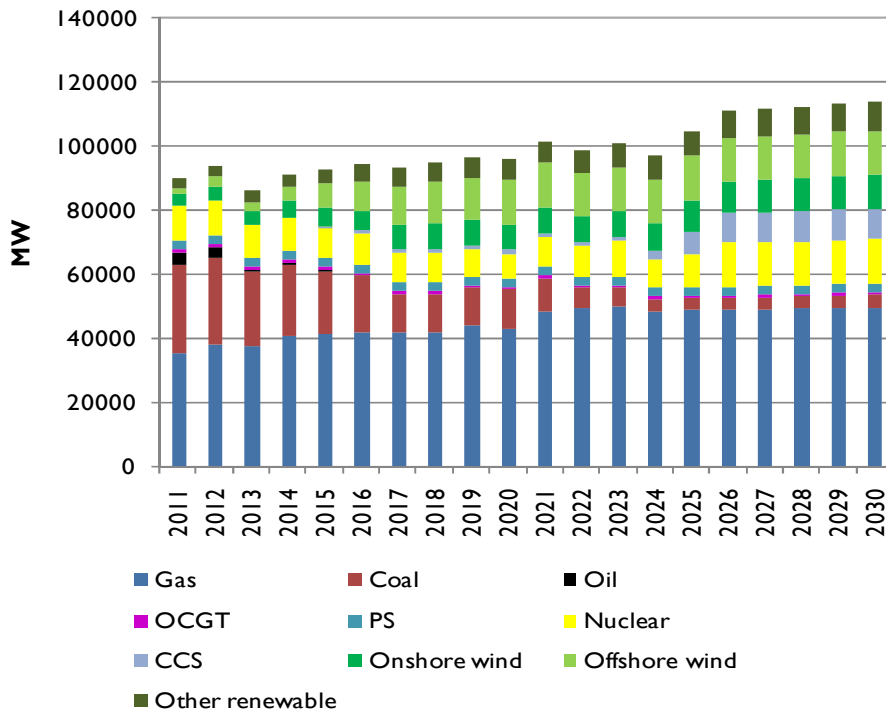
There are wider issues in relation to expansion factor calculations. Reinforcement by HVDC cables is taking place for the benefit of GB customers and generators. Using HVDC is driven by Government climate change obligations and by the difficulties in getting planning for overhead lines. However, this should not result in excessive costs being allocated to those generators on one end of the HVDC cables. In particular, it should not be for those generators to pick up the fixed costs of reinforcement through a locational tariff. Indeed, without removal of these fixed costs, the resulting TNUoS charges may prevent the investment in the very generation that the HVDC cables are intended to serve.

## Annex 15 – Impact assessment modelling results

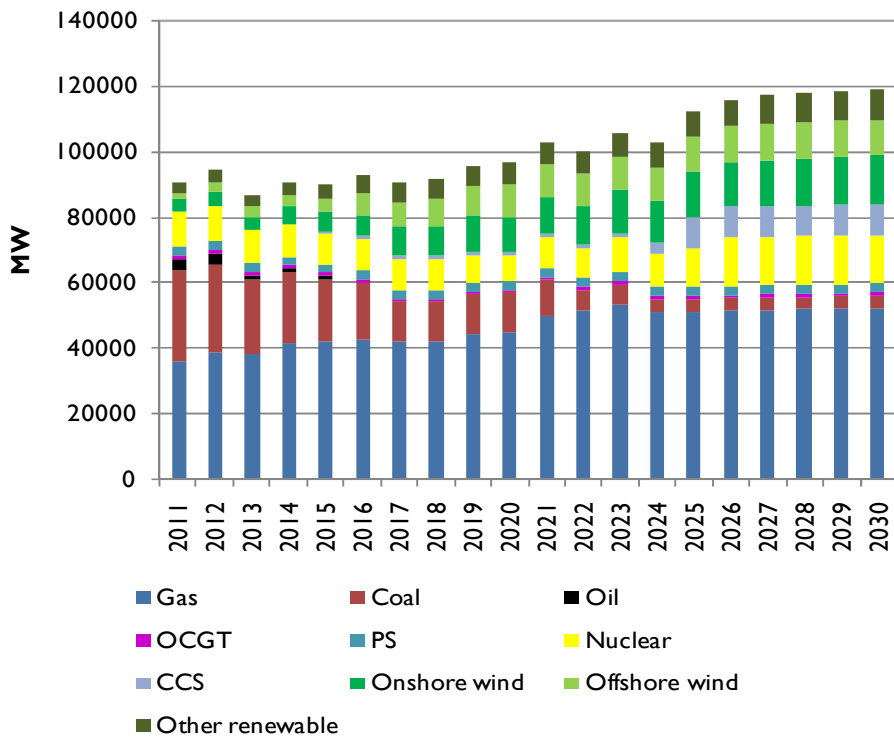
The following charts, graphs and data tables are the results of the stage 2 impact assessment modeling undertaken by National Grid, and are presented in 2012/13 prices. All results provided are illustrative only, and should be considered as guidance to future possible trends rather than absolute forecasts. Illustrative tariffs produced have differing input assumptions to those illustrative tariffs provided in Annex 11, and therefore should not be directly compared.

These results have previously been distributed to the CMP213 Workgroup to inform Workgroup voting decisions. A companion spreadsheet containing the underlying data used to produce these graphs was also circulated. If you would like a copy of this spreadsheet, please contact the code administrator at: [cusc.team@nationalgrid.com](mailto:cusc.team@nationalgrid.com)

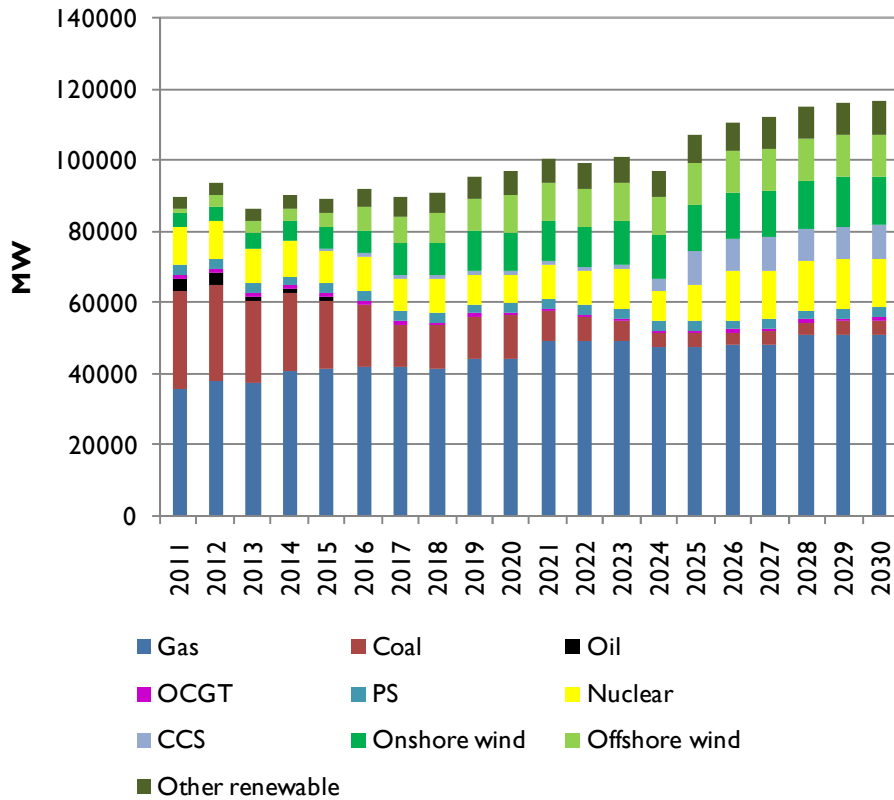
### A.15.1. Generation Mixes



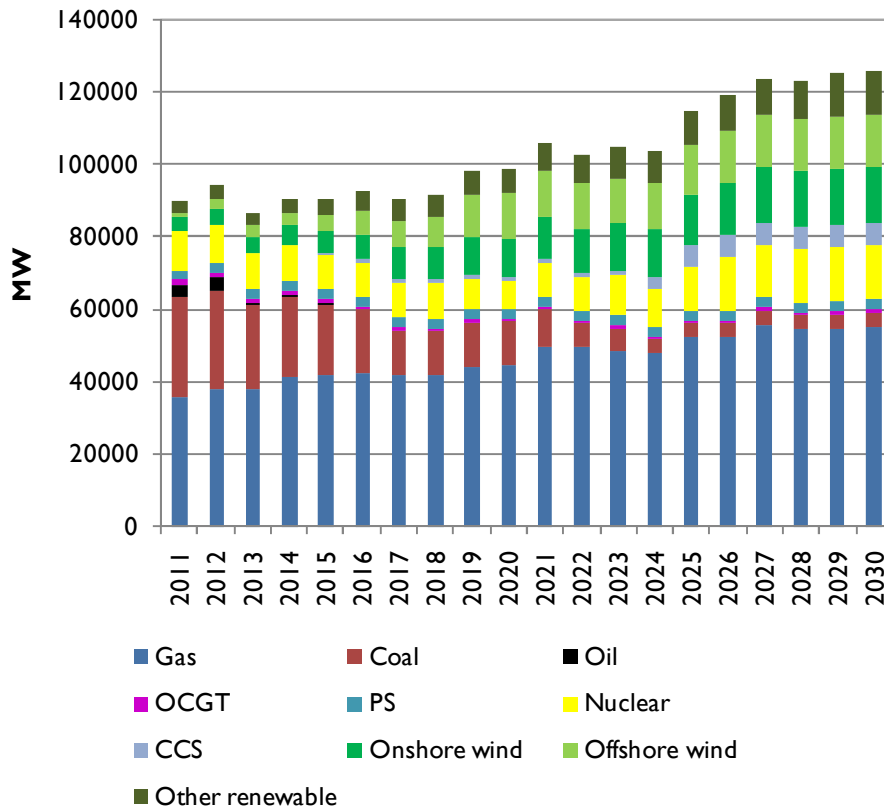
**Figure A15.1 – Generation Mix: Status Quo**



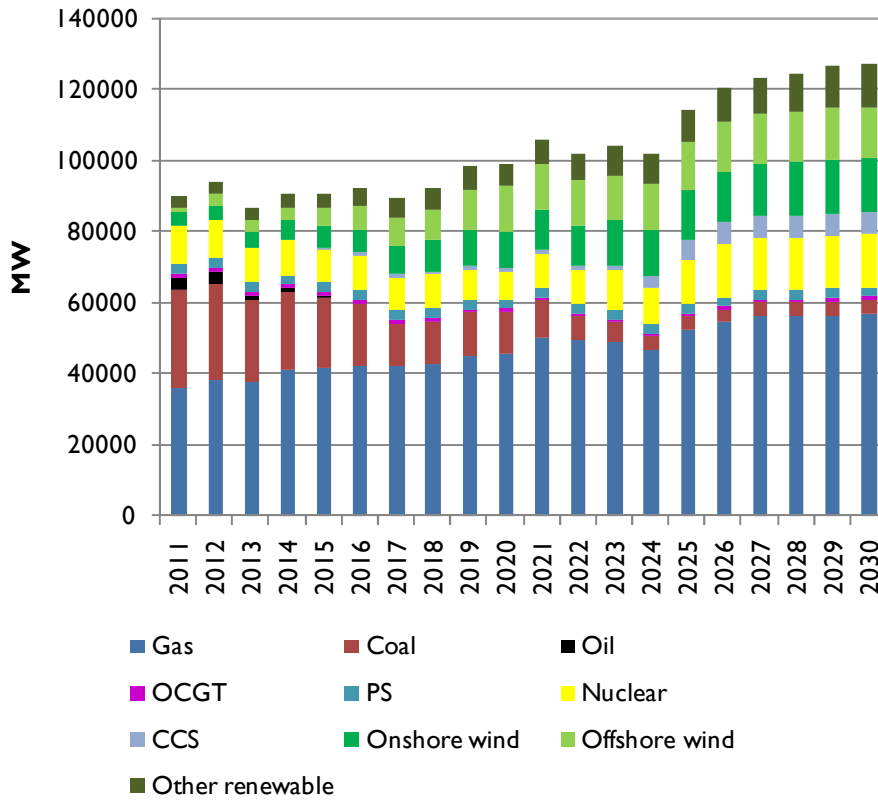
**Figure A15.2 – Generation Mix: Original**



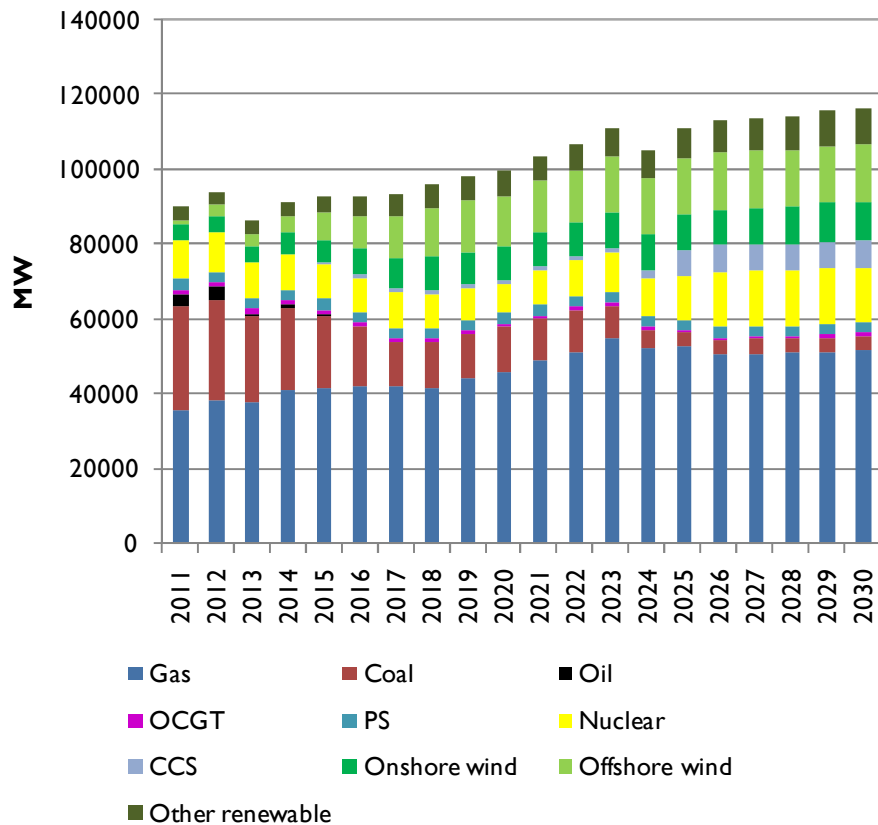
**Figure A15.3 – Generation mix: Original 50% HVDC Converters**



**Figure A15.4 – Generation mix: Diversity 1**



**Figure A15.5 – Generation mix: Diversity 2**



**Figure A15.6 – Generation mix: Diversity 3**



### A.15.2. Capacity Margins

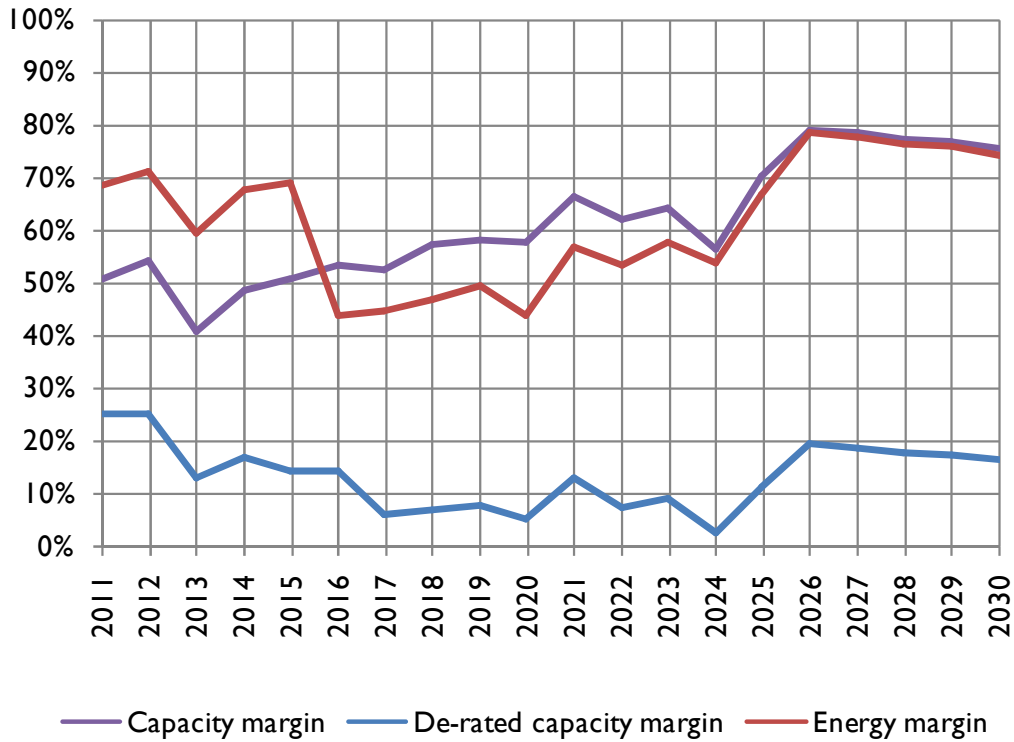


Figure A15.7 – Capacity margins: Status Quo

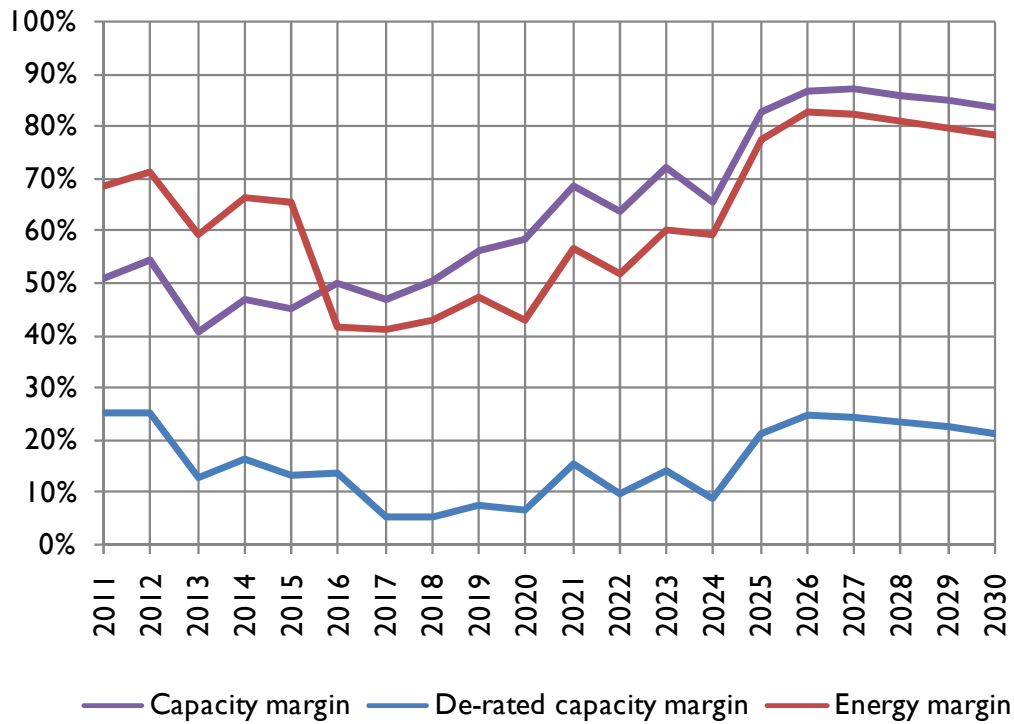
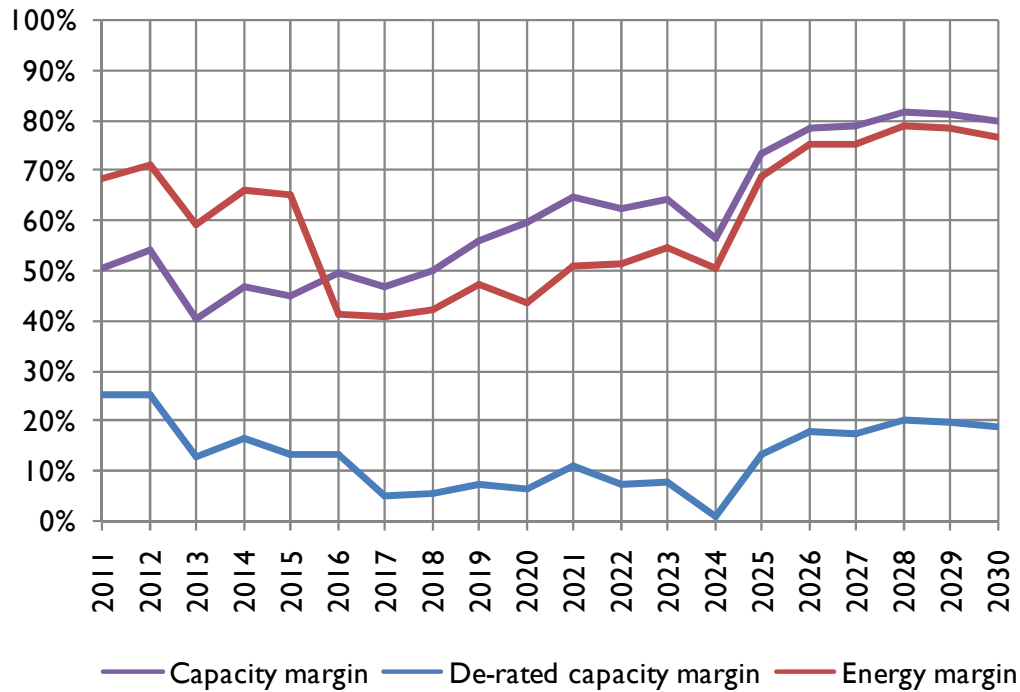
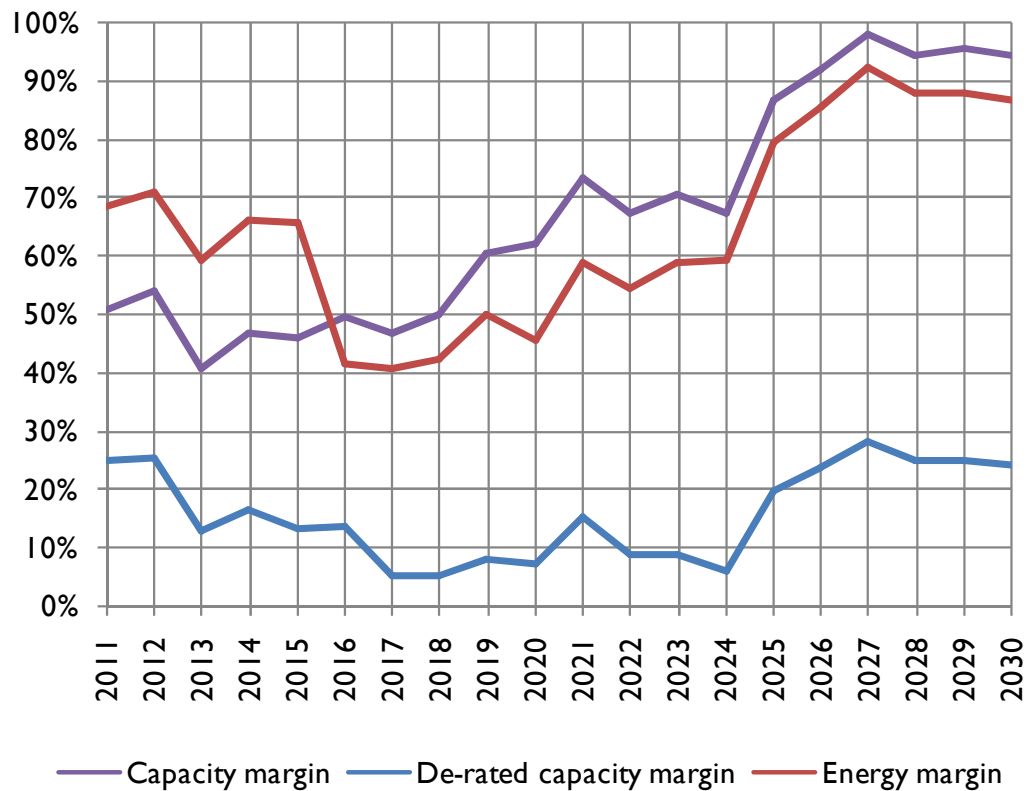


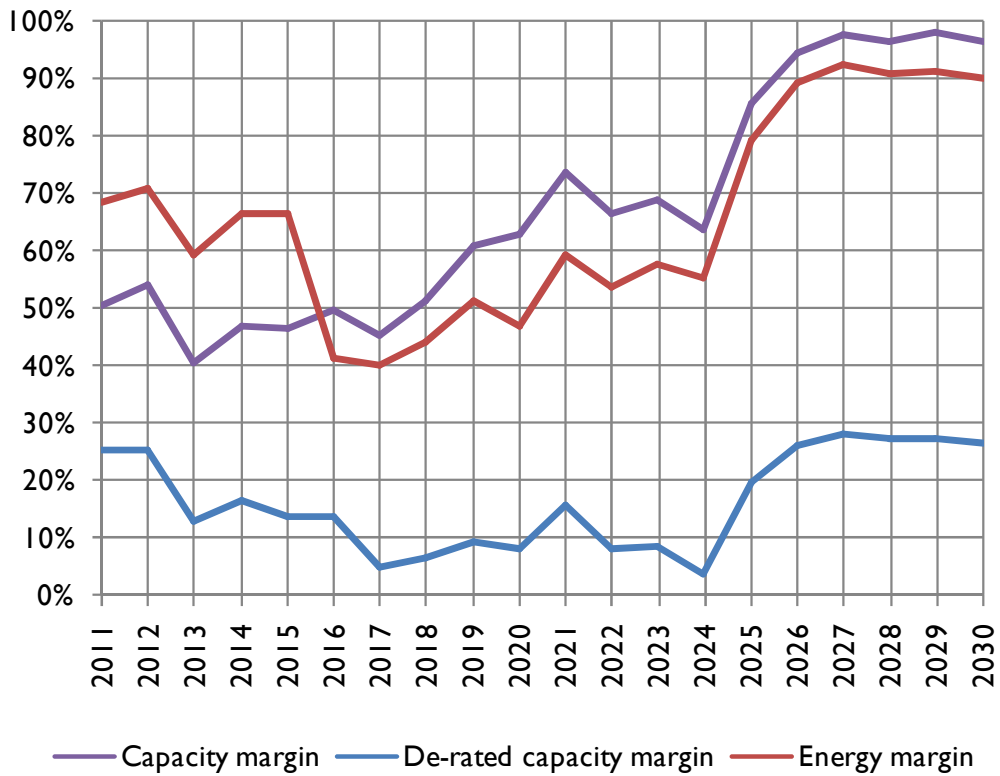
Figure A15.8 – Capacity margins: Original



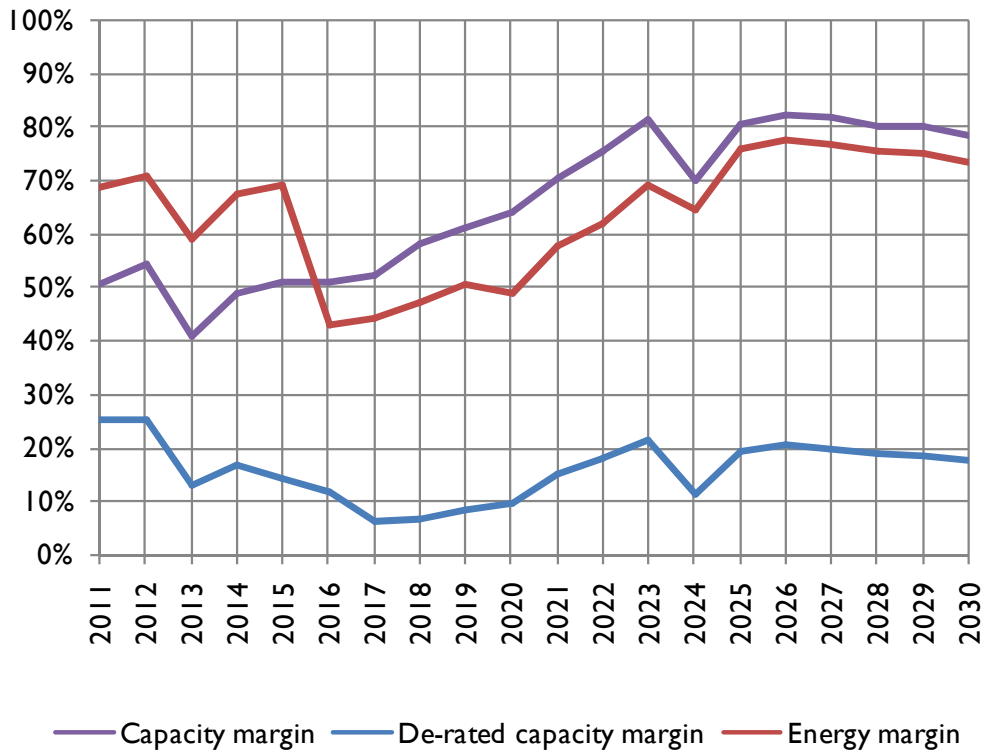
**Figure A15.9 – Capacity margins: Original 50% HVDC Converters**



**Figure A15.10 – Capacity margins: Diversity 1**

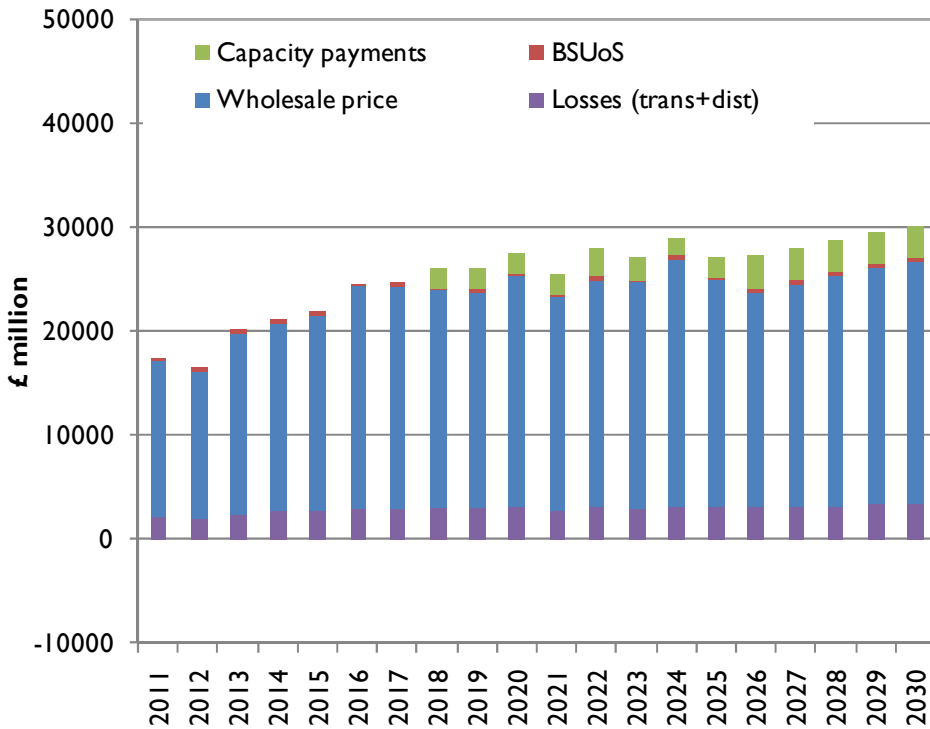


**Figure A15.11 – Capacity margins: Diversity 2**

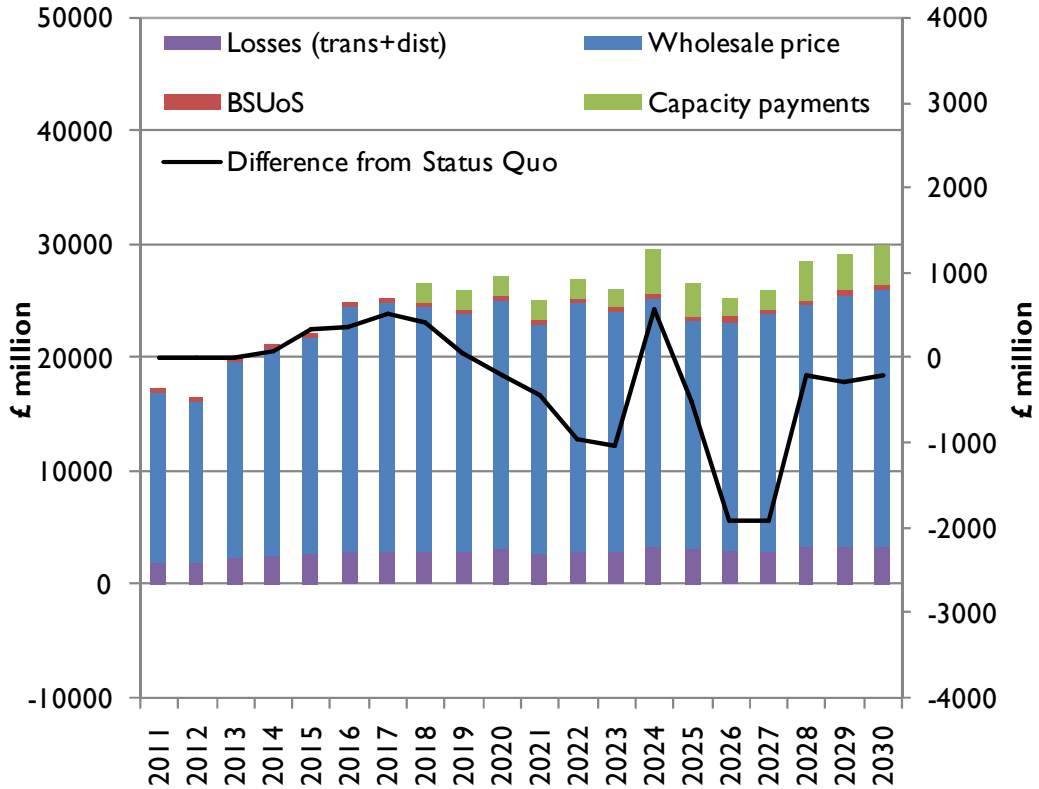


**Figure A15.12 – Capacity margins: Diversity 3**

**A.15.3. Wholesale Costs**



**Figure A15.13 – Wholesale costs: Status Quo**



**Figure A15.14 – Wholesale costs: Original**

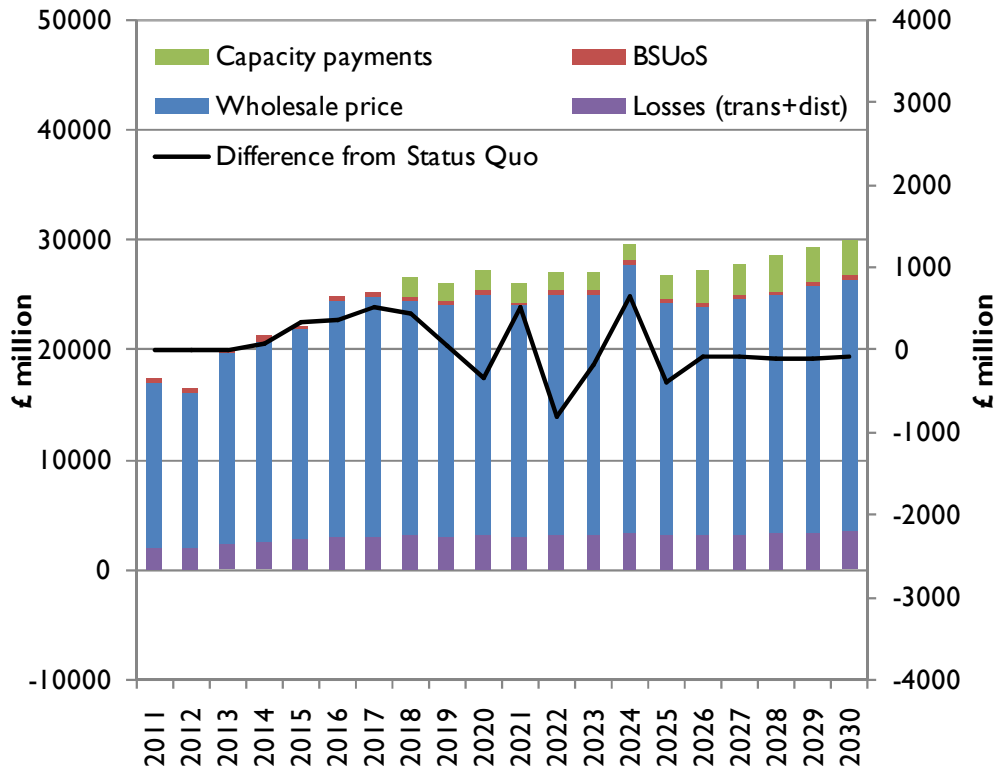


Figure A15.15 – Wholesale costs: Original 50% HVDC Converters

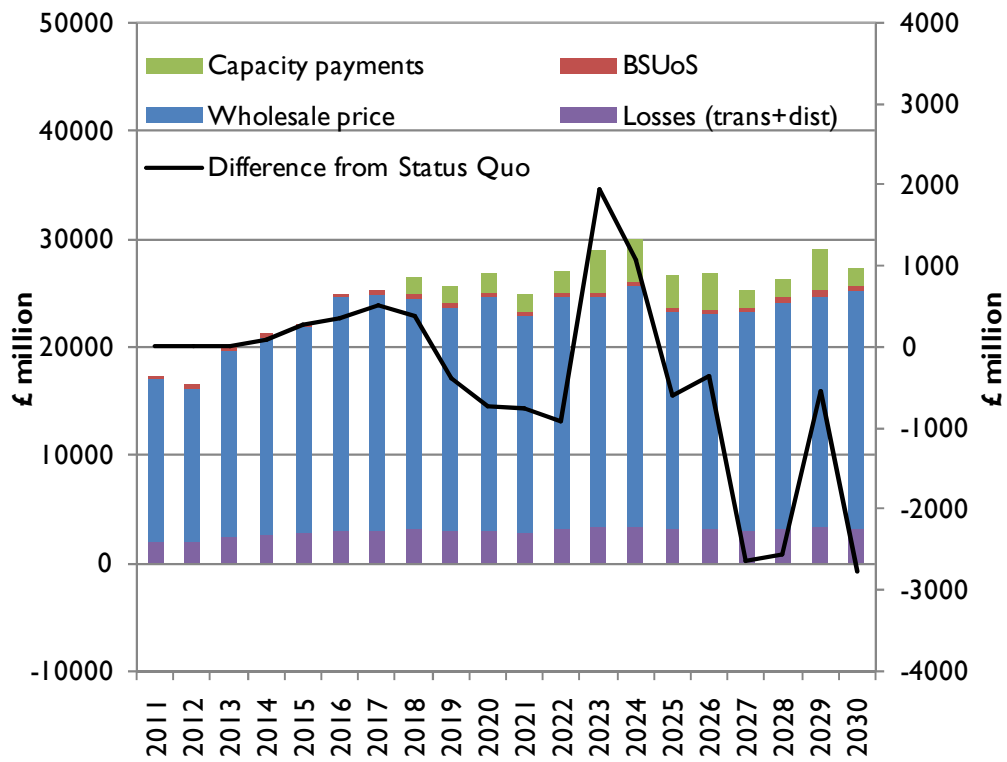


Figure A15.16 – Wholesale costs: Diversity 1

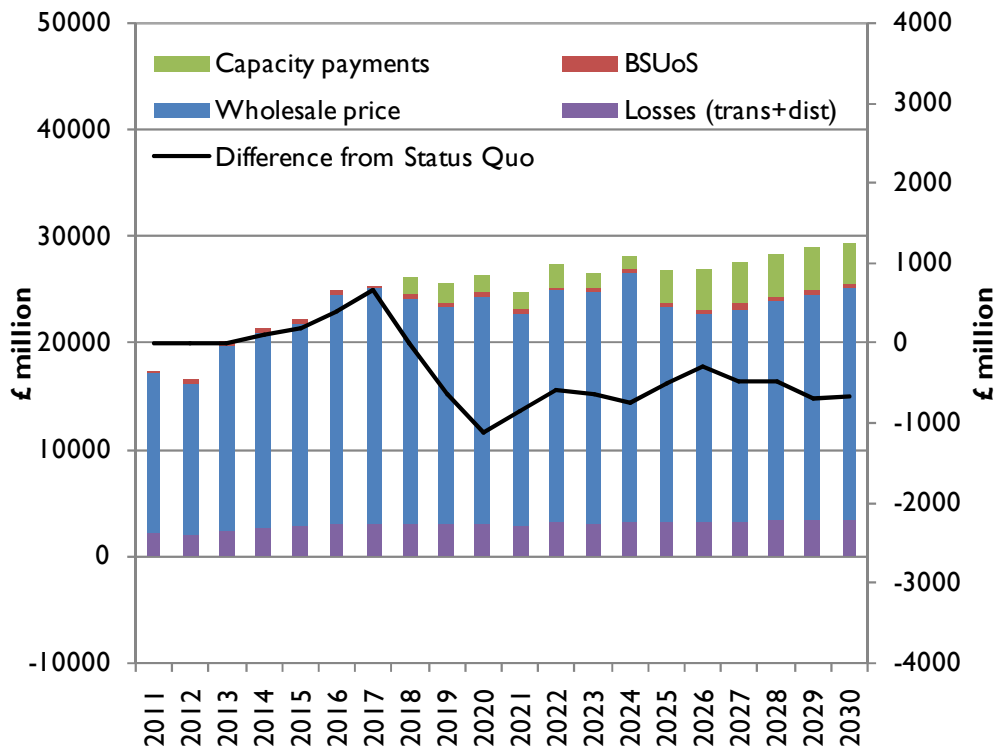


Figure A15.17 – Wholesale costs: Diversity 2

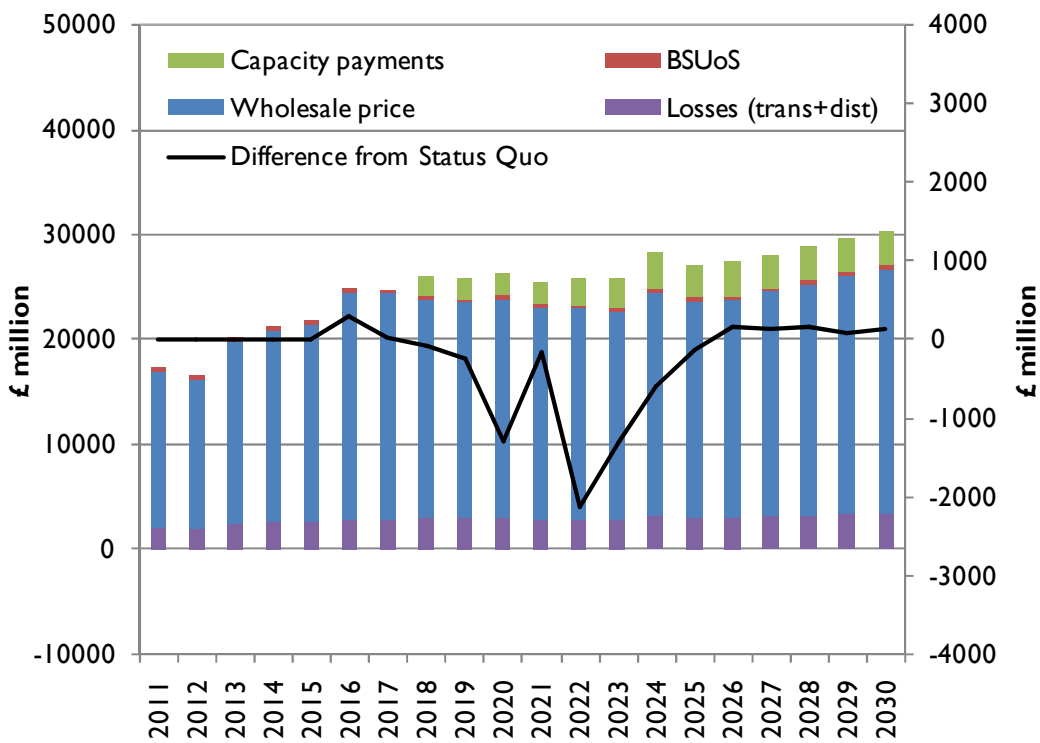
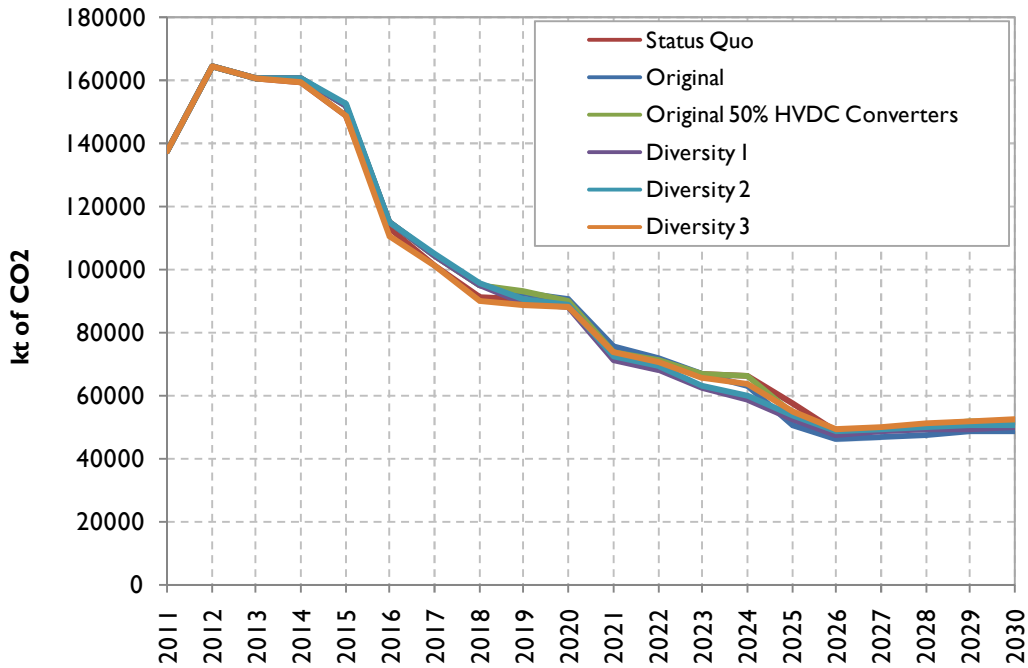
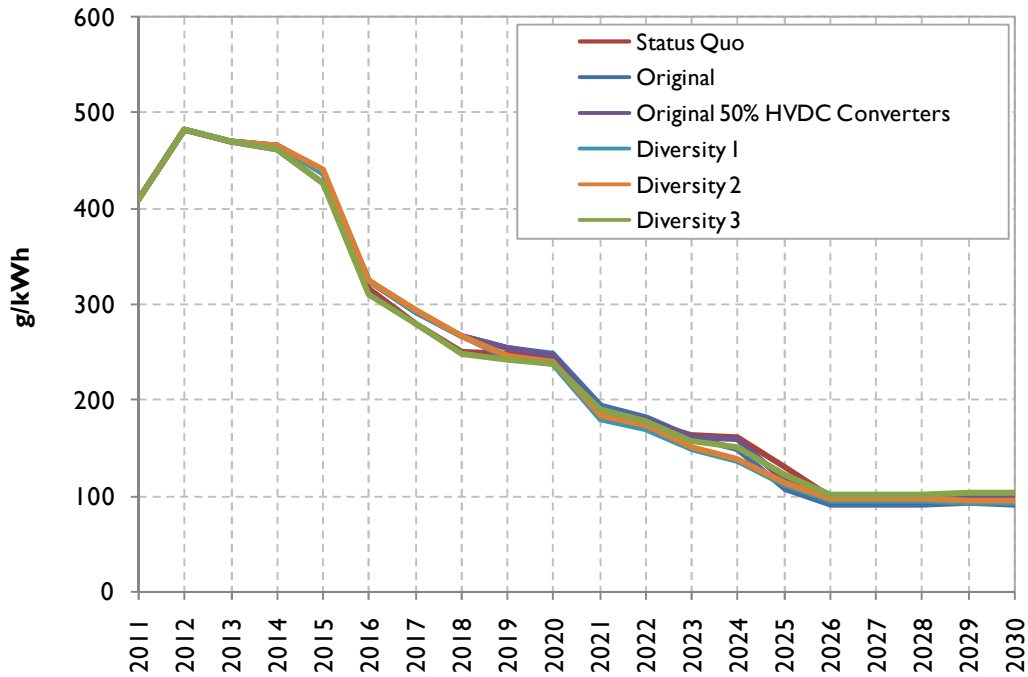


Figure A15.18 – Wholesale costs: Diversity 3

**A.15.4. Other Output Data Charts**



**Figure A15.19 – CO<sub>2</sub> Emissions**



**Figure A15.20 – Carbon Intensity**

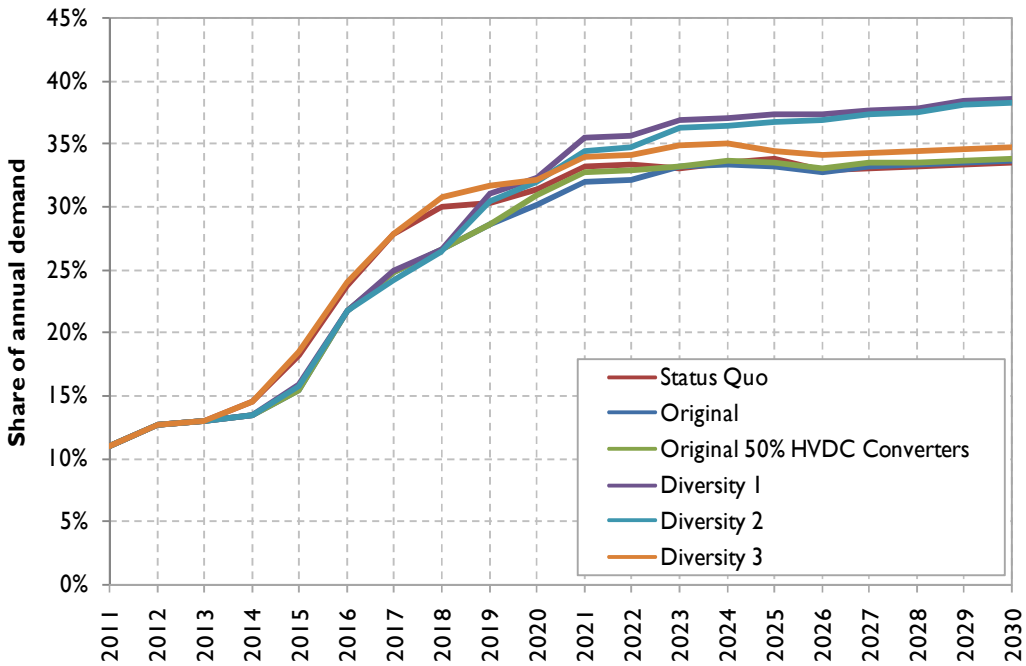


Figure A15.21 – Percentage of generation from renewable sources

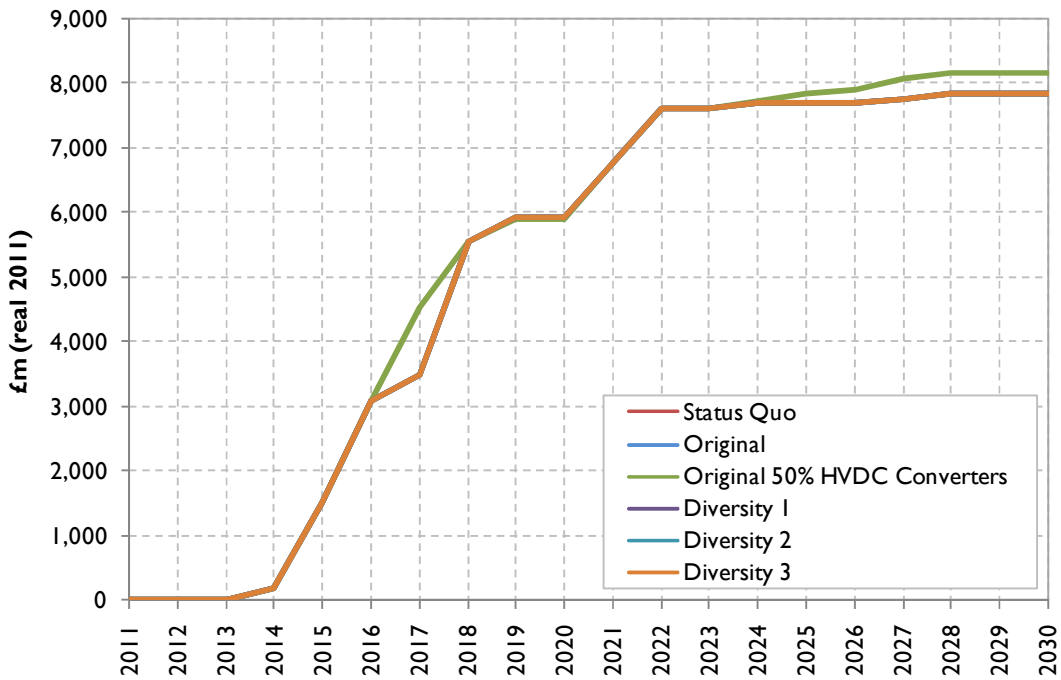


Figure A15.22 – Cost of transmission investment



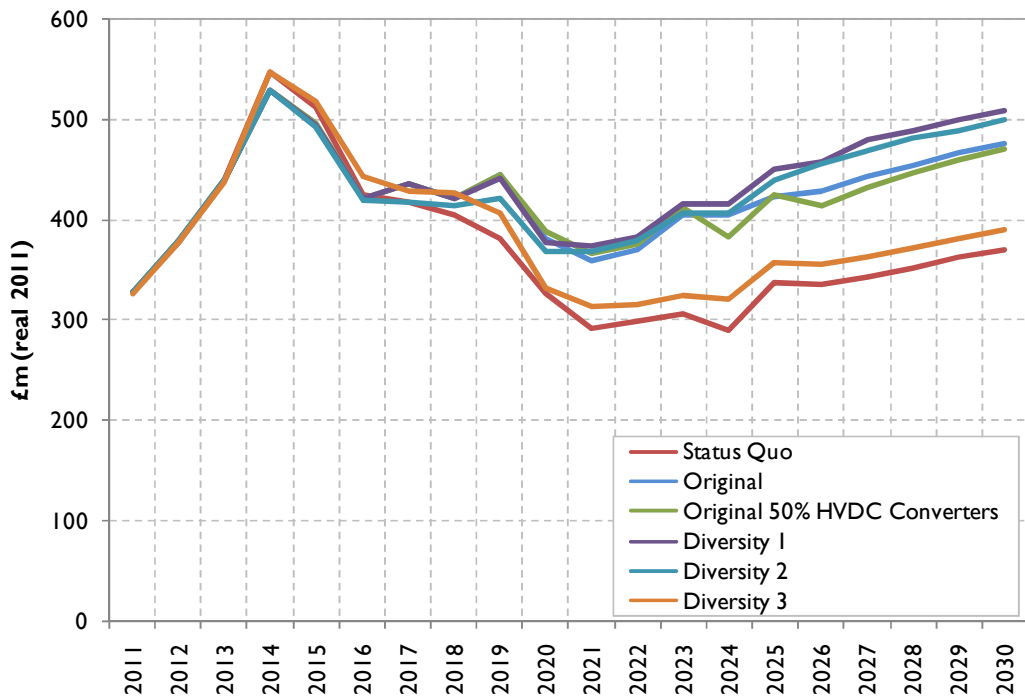


Figure A15.23 – Cost of transmission losses

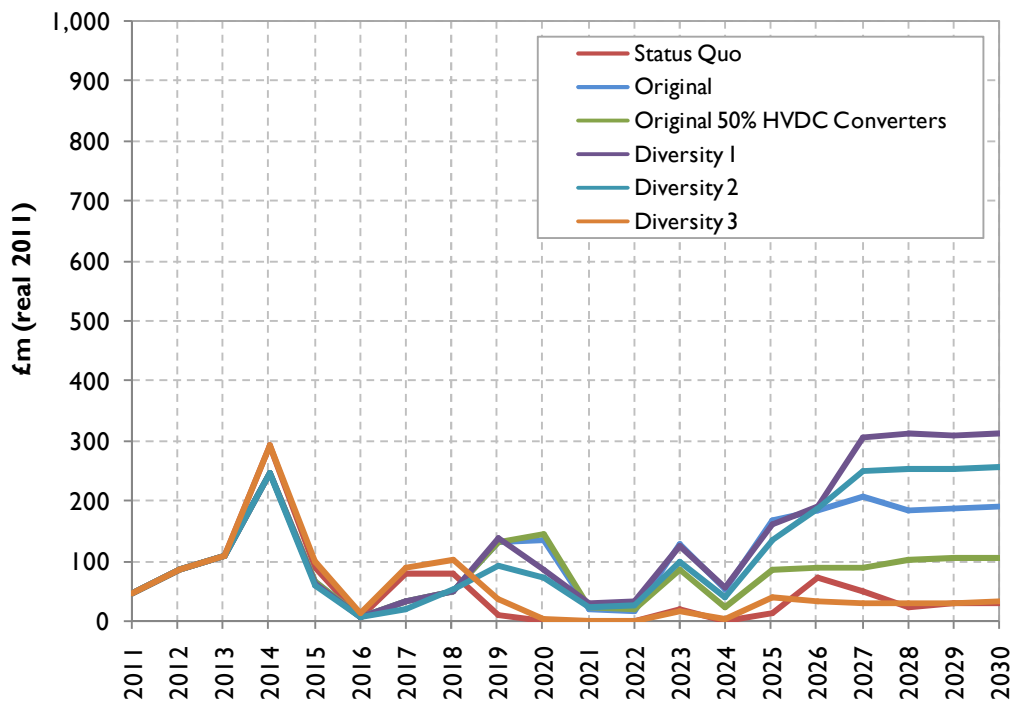
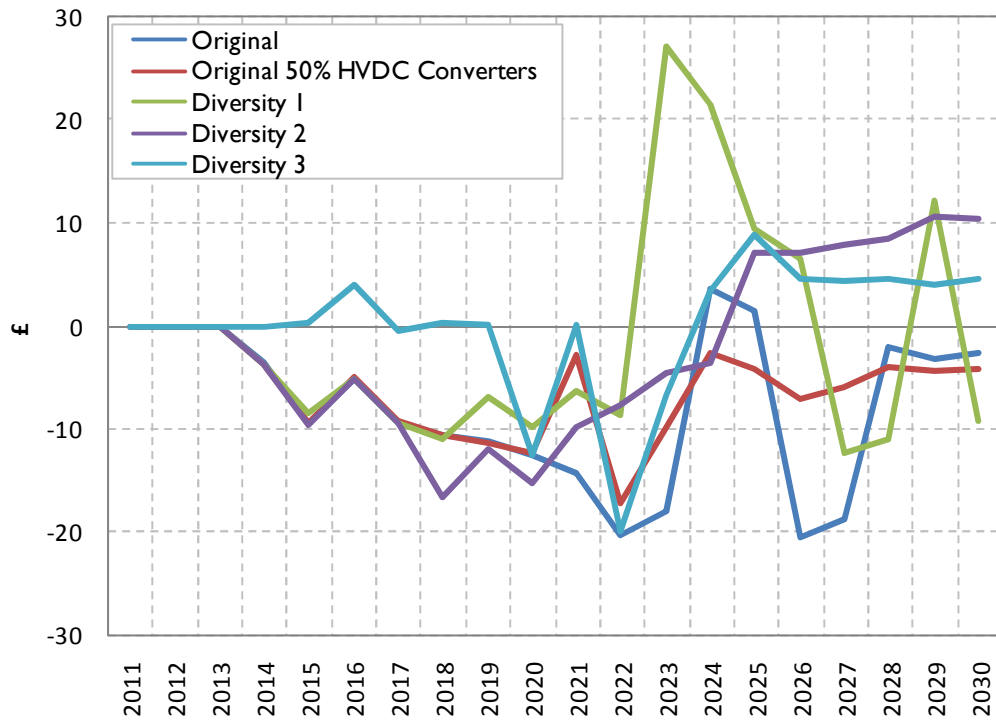


Figure A15.24 – Transmission constraint costs



**Figure A15.25 – Change in average consumer bill from status quo**

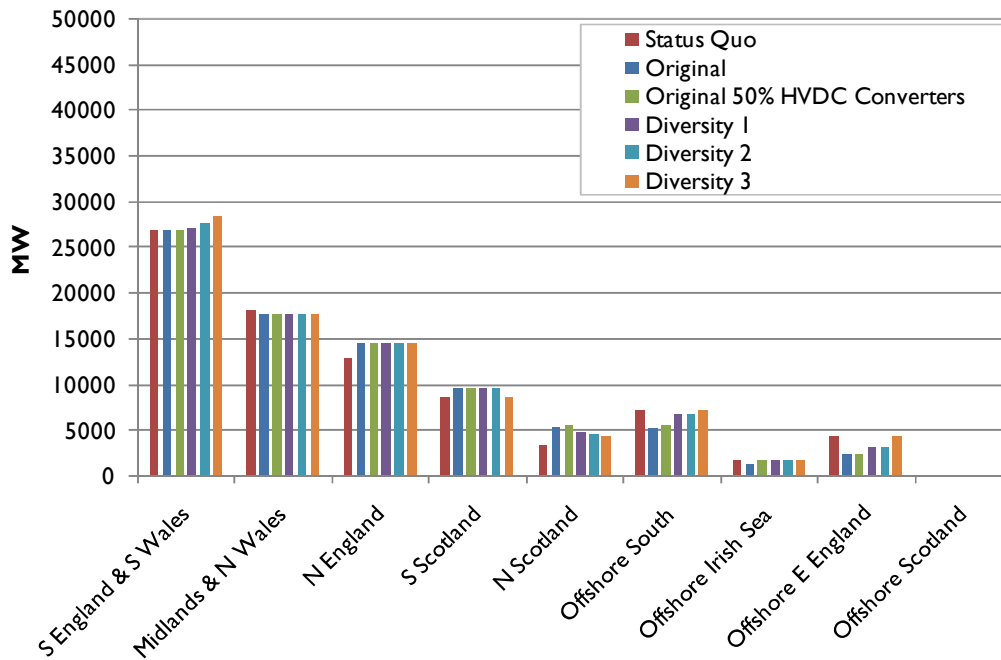


Figure A15.26 – Generation Capacity by Zone: 2020

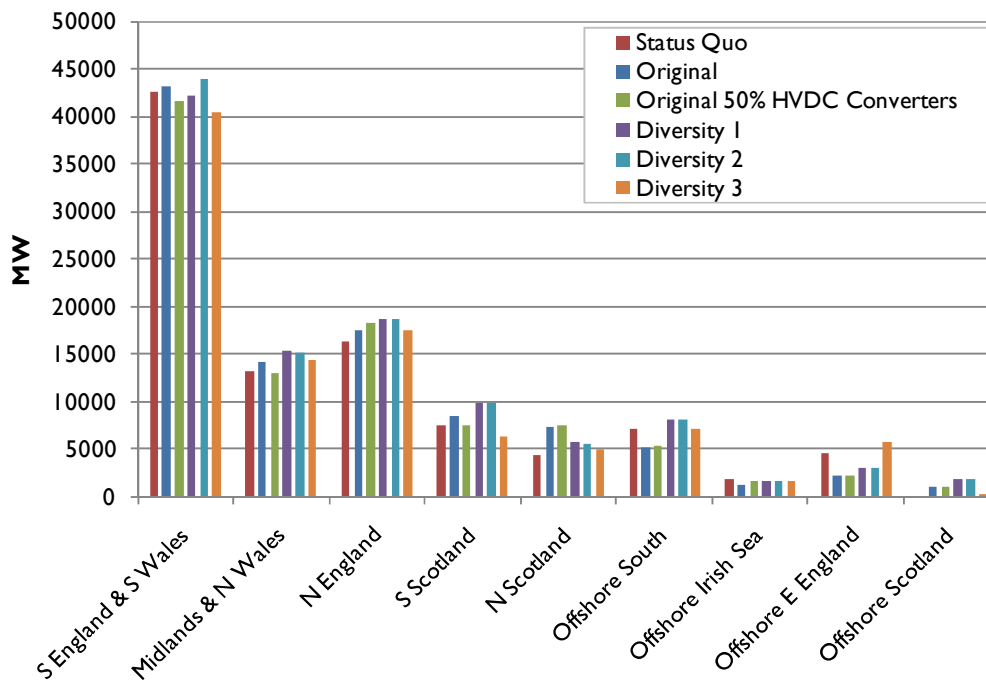


Figure A15.27 – Generation Capacity by Zone: 2030

### A.15.5. CfD Strike Prices

**Table A15.1: CfD Strike Price - Status Quo**

**Table A15.2: CfD Strike Price – Original**

(£/MWh)	2018-2020	2021-2023	2024-2026	2027-2028	2029-2030
Nuclear	104	101	96	93	92
Coal + CCS	137	137	136	136	137
CCGT + CCS	103	102	102	102	102
Onshore wind	95	93	90	89	88
Offshore wind	138	127	119	116	111
Wave	318	269	219	198	180
Tidal Stream	305	251	221	200	183
Biomass regular	119	116	114	113	113

**Table A15.3: CfD Strike Price - Original 50% HVDC Converters**

(£/MWh)	2018-2020	2021-2023	2024-2026	2027-2028	2029-2030
Nuclear	104	100	95	92	91
Coal + CCS	137	137	136	135	137
CCGT + CCS	103	102	102	102	102
Onshore wind	94	92	90	89	88
Offshore wind	136	127	119	115	111
Wave	314	269	218	198	180
Tidal Stream	302	251	221	200	183
Biomass regular	118	116	114	113	113

**Table A15.4: CfD Strike Price - Diversity 1**

(£/MWh)	2018-2020	2021-2023	2024-2026	2027-2028	2029-2030
Nuclear	104	100	95	93	92
Coal + CCS	137	137	136	136	137
CCGT + CCS	103	102	102	101	101
Onshore wind	98	97	96	95	94
Offshore wind	140	132	126	122	118
Wave	326	282	236	215	196
Tidal Stream	309	260	234	212	194
Biomass regular	121	120	120	119	119

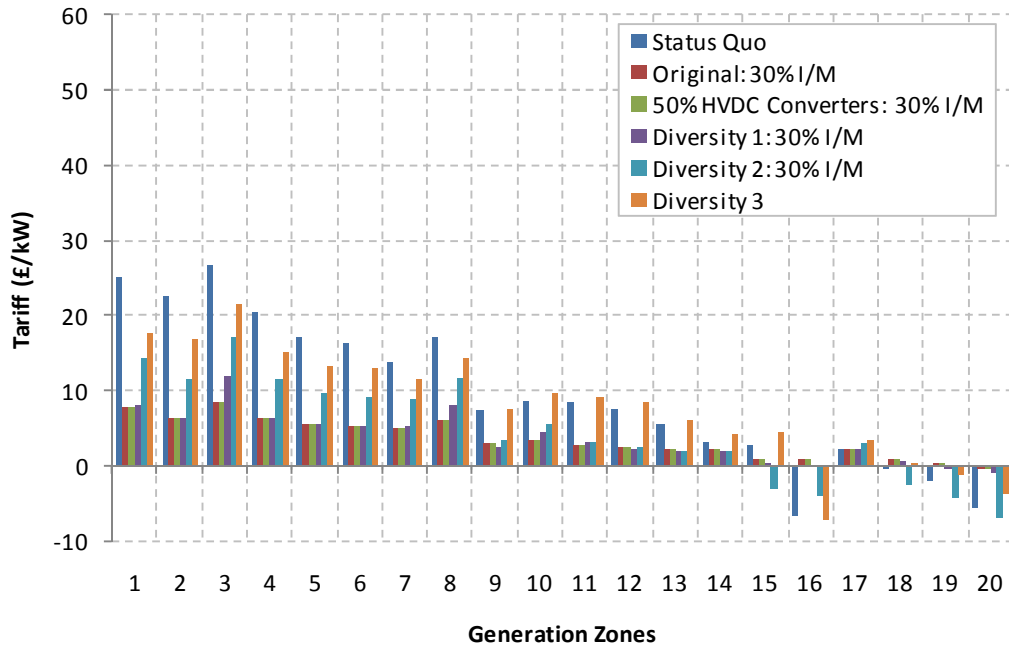
**Table A15.5: CfD Strike Price - Diversity 2**

(£/MWh)	2018-2020	2021-2023	2024-2026	2027-2028	2029-2030
Nuclear	104	100	95	93	92
Coal + CCS	137	137	136	136	137
CCGT + CCS	103	102	102	101	101
Onshore wind	98	97	97	96	95
Offshore wind	139	131	126	123	119
Wave	325	282	237	217	198
Tidal Stream	308	259	235	213	195
Biomass regular	120	120	120	120	120

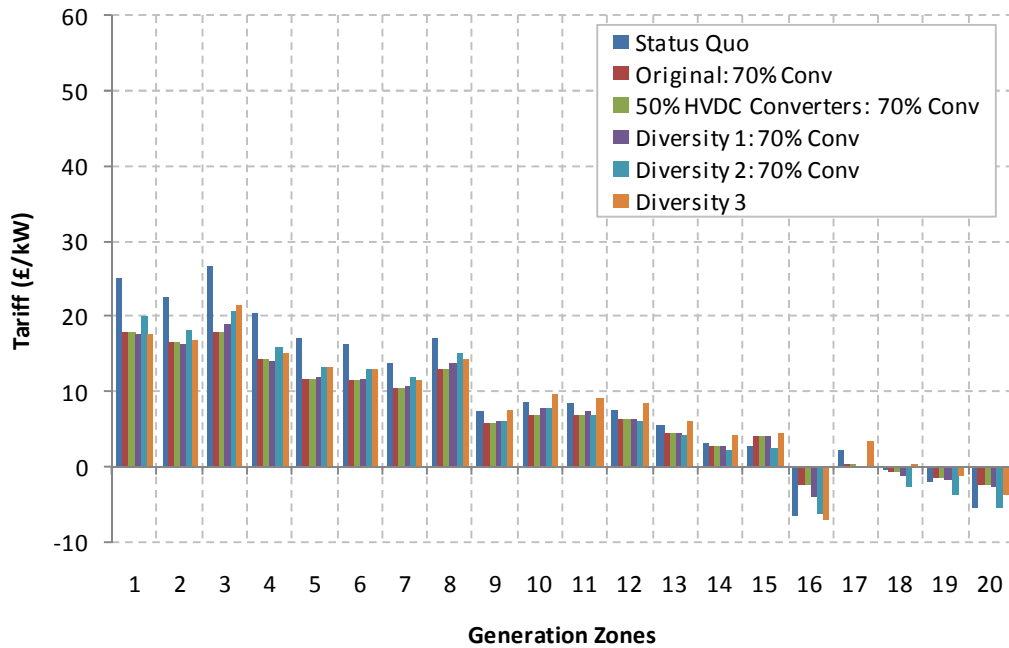
**Table A15.6: CfD Strike Price - Diversity 3**

(£/MWh)	2018-2020	2021-2023	2024-2026	2027-2028	2029-2030
Nuclear	104	101	96	94	92
Coal + CCS	138	138	137	137	138
CCGT + CCS	104	103	102	102	102
Onshore wind	97	96	95	94	93
Offshore wind	124	116	110	107	102
Wave	314	271	225	205	186
Tidal Stream	298	251	225	205	188
Biomass regular	117	116	116	115	115

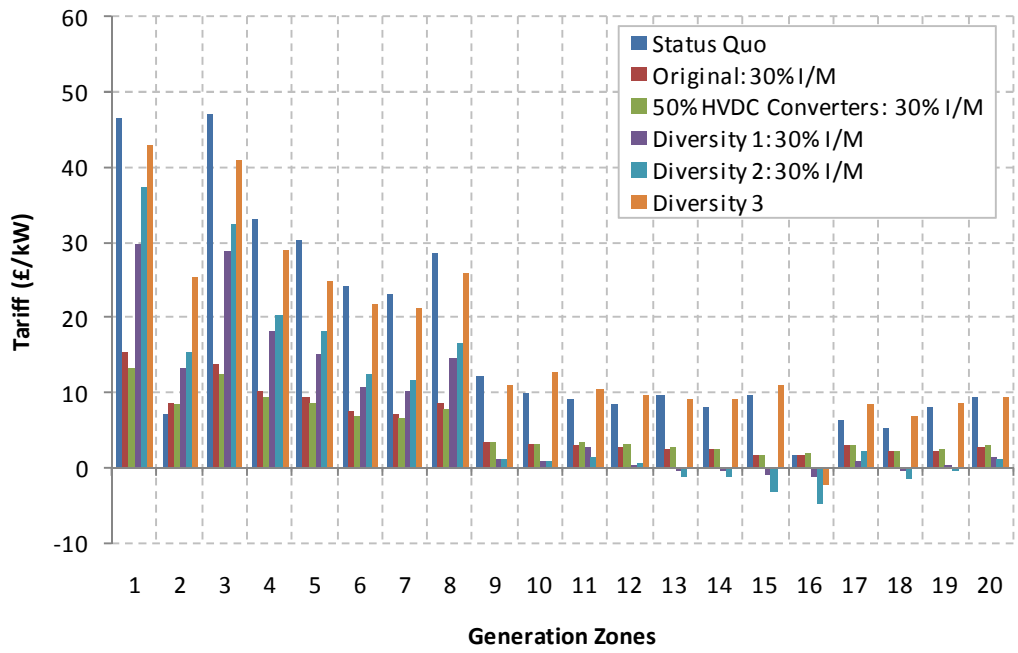
### A.15.6. Illustrative Tariffs



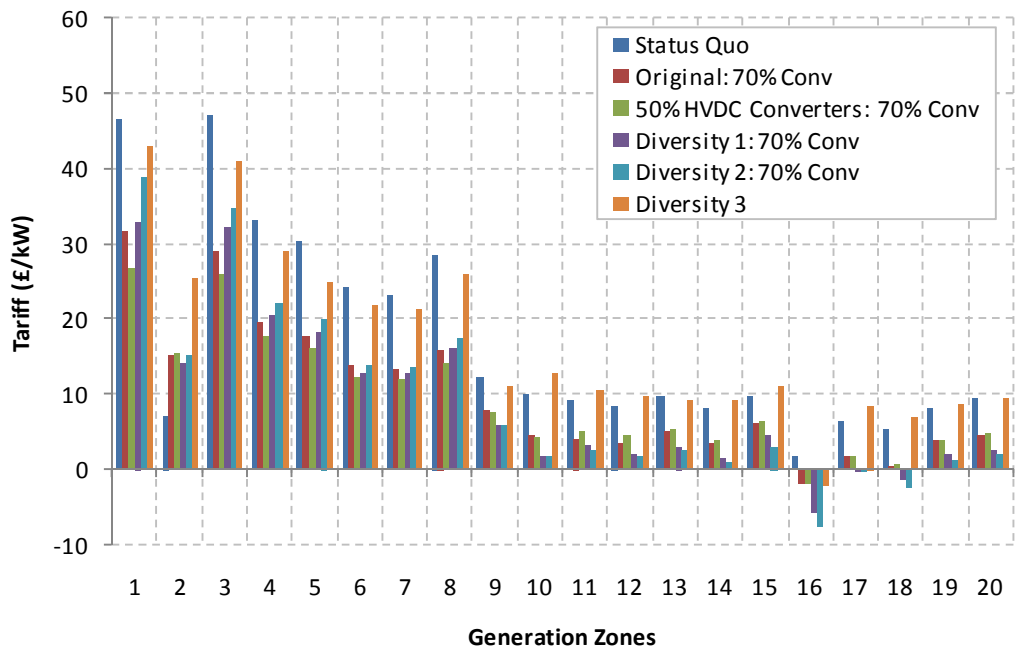
**Figure A15.28 – 2012 illustrative tariffs: Intermittent Generation (30% Annual Load Factor)**



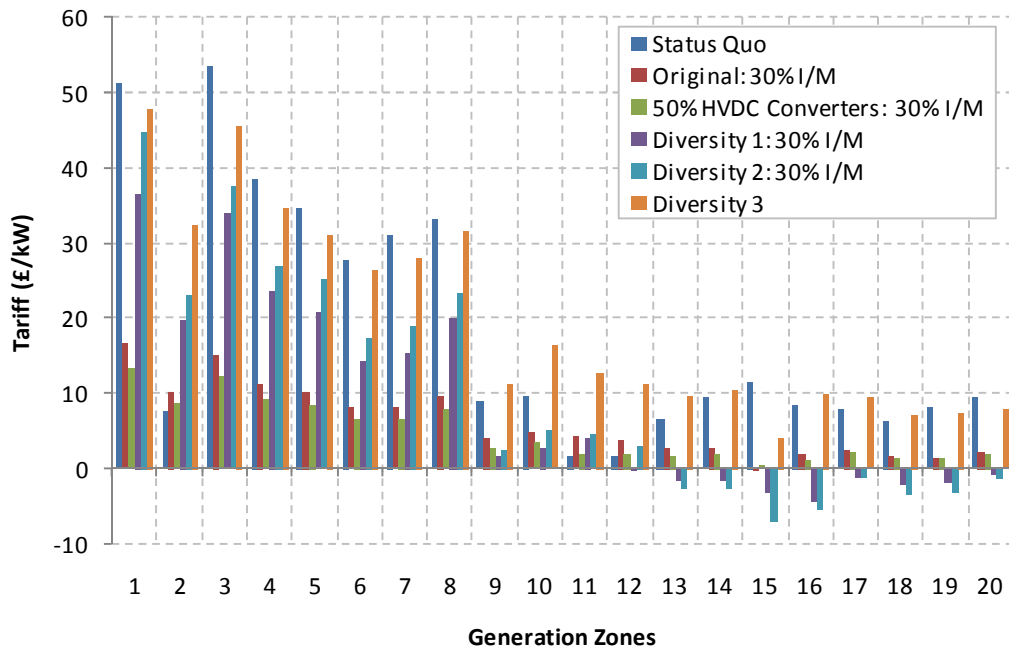
**Figure A15.29 – 2012 illustrative tariffs: Conventional Generation (70% Annual Load Factor)**



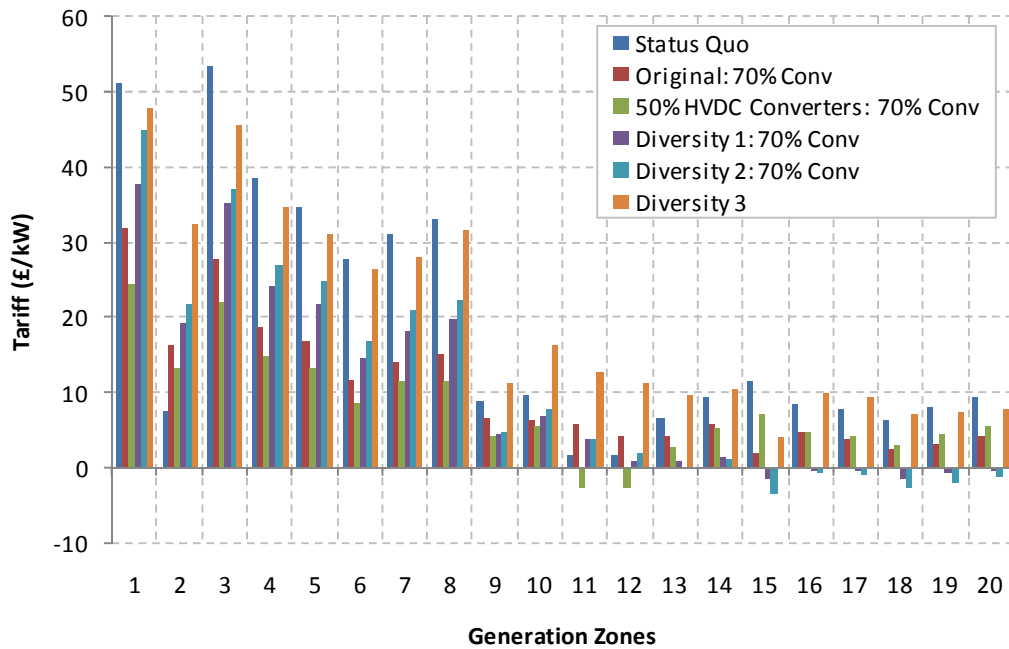
**Figure A15.30 – 2020 illustrative tariffs: Intermittent Generation (30% Annual Load Factor)**



**Figure A15.31 – 2020 illustrative tariffs: Conventional Generation (70% Annual Load Factor)**

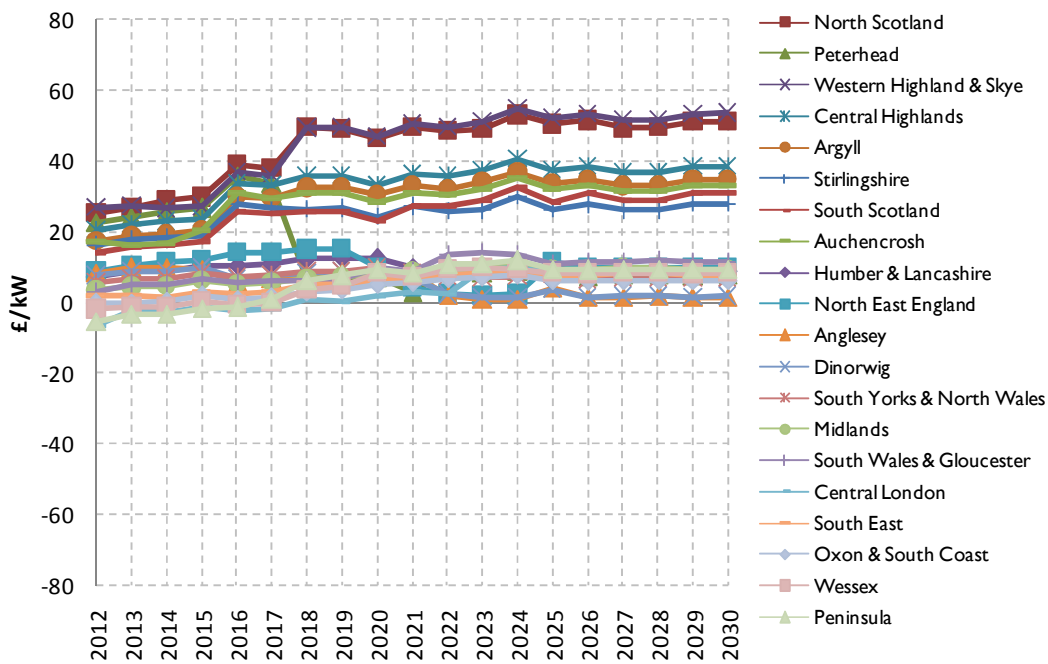


**Figure A15.32 – 2030 illustrative tariffs: Intermittent Generation (30% Annual Load Factor)**



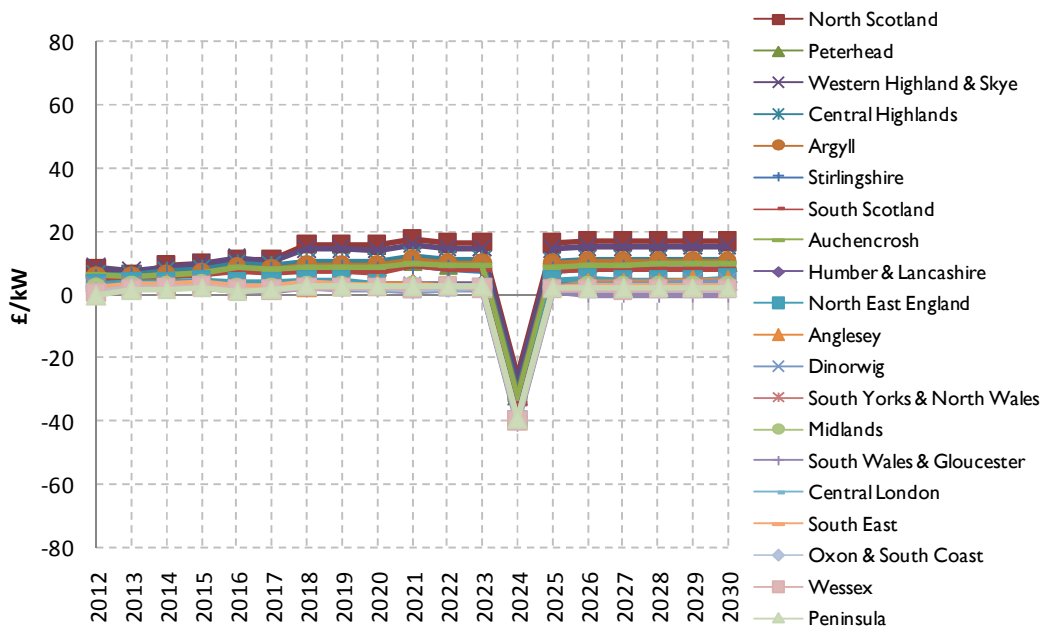
**Figure A15.33 – 2030 illustrative tariffs: Conventional Generation (70% Annual Load Factor)**





**Figure A15.34 – Illustrative wider generation tariffs by zone:  
Status Quo**

**Intermittent generation (30% Annual Load Factor)**



**Figure A15.35 – Illustrative wider generation tariffs by zone:  
Original proposal**

### Conventional generation (30% Annual Load Factor)

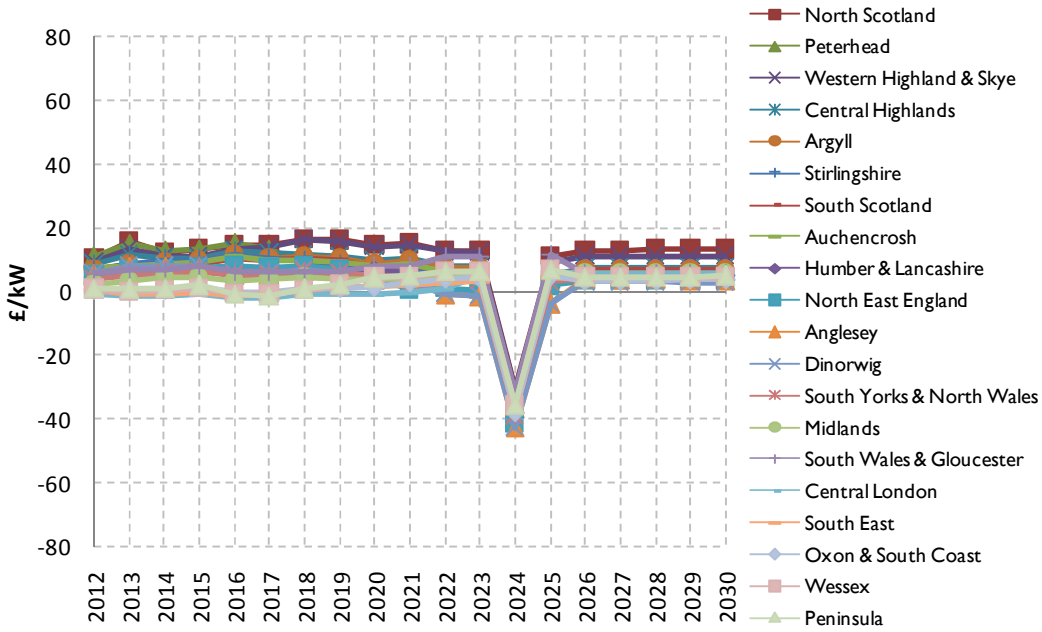


Figure A15.36 – Illustrative wider generation tariffs by zone:  
Original proposal

### Conventional generation (70% Annual Load Factor)

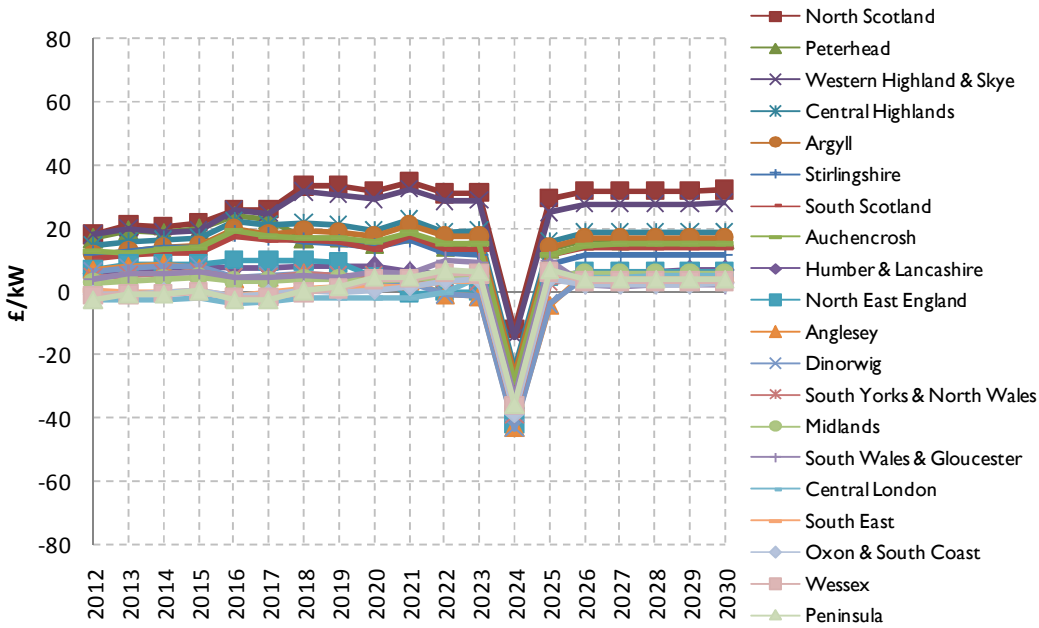
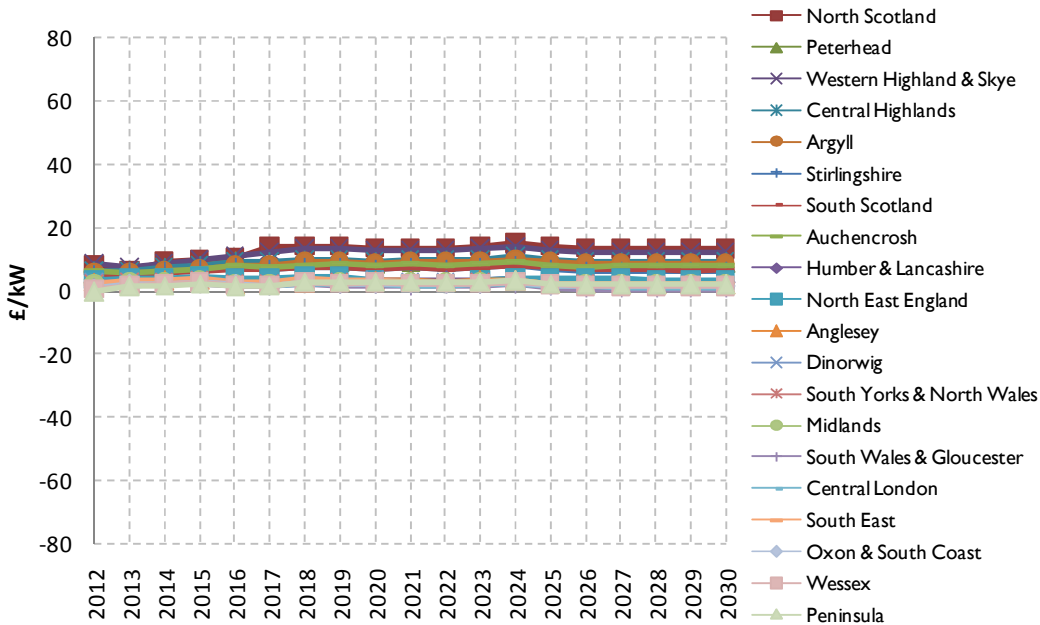


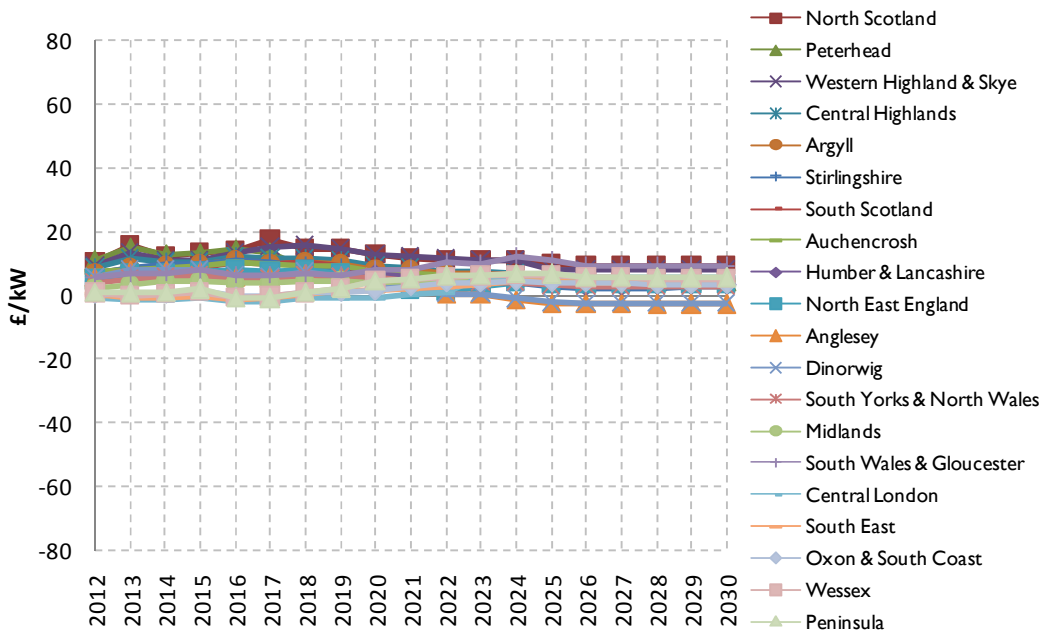
Figure A15.37 – Illustrative wider generation tariffs by zone:  
Original proposal

### Intermittent generation (30% Annual Load Factor)



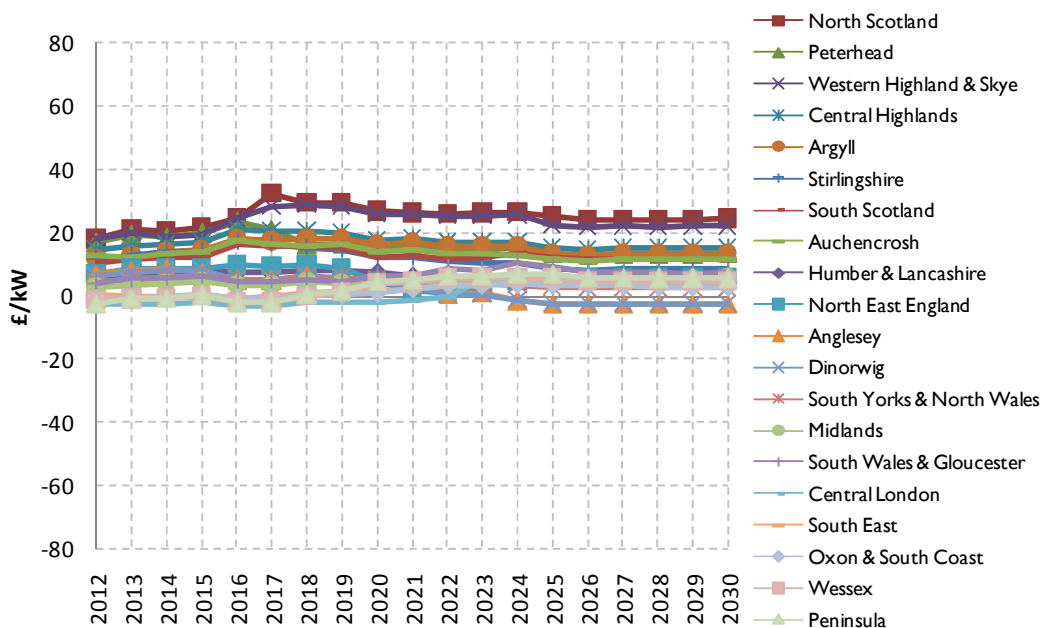
**Figure A15.38 – Illustrative wider generation tariffs by zone:  
Original 50% HVDC Converters**

### Conventional generation (30% Annual Load Factor)



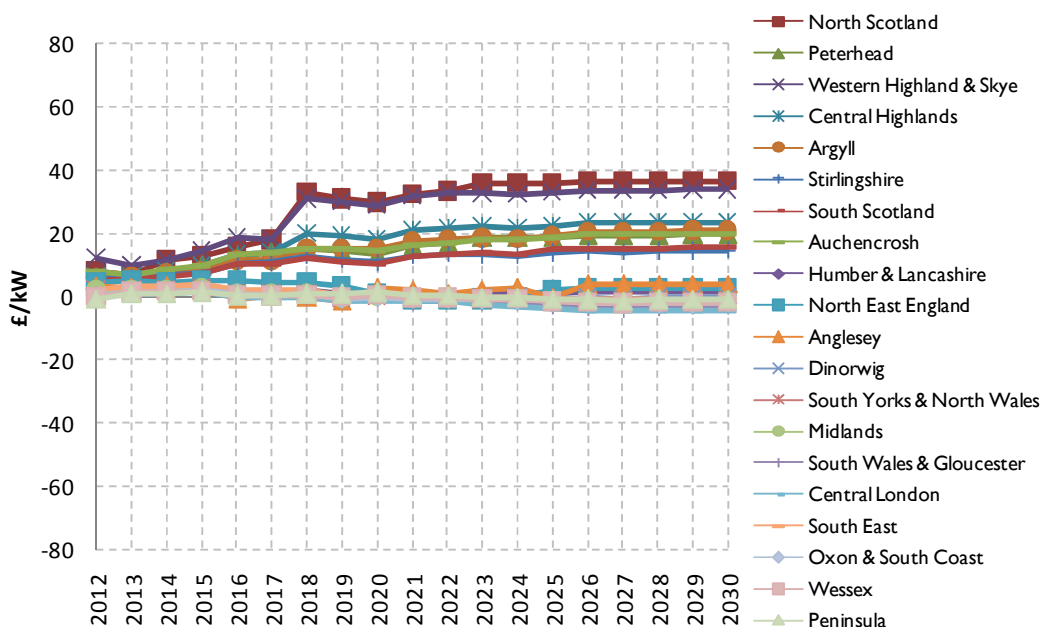
**Figure A15.39 – Illustrative wider generation tariffs by zone:  
Original 50% HVDC Converters**

### Conventional generation (70% Annual Load Factor)



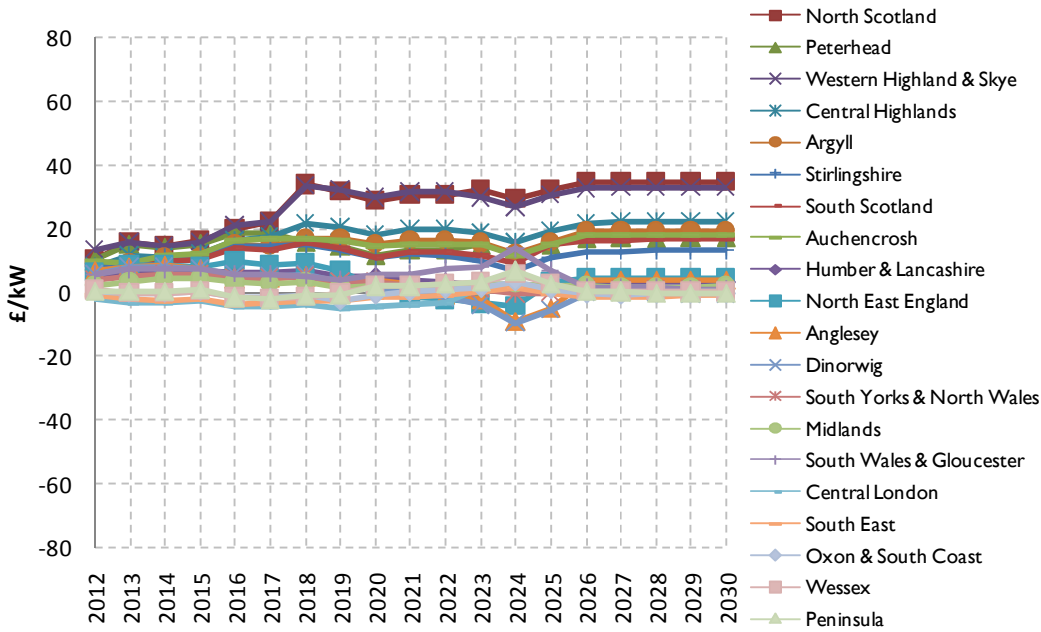
**Figure A15.40 – Illustrative wider generation tariffs by zone:  
Original 50% HVDC Converters**

### Intermittent generation (30% Annual Load Factor)



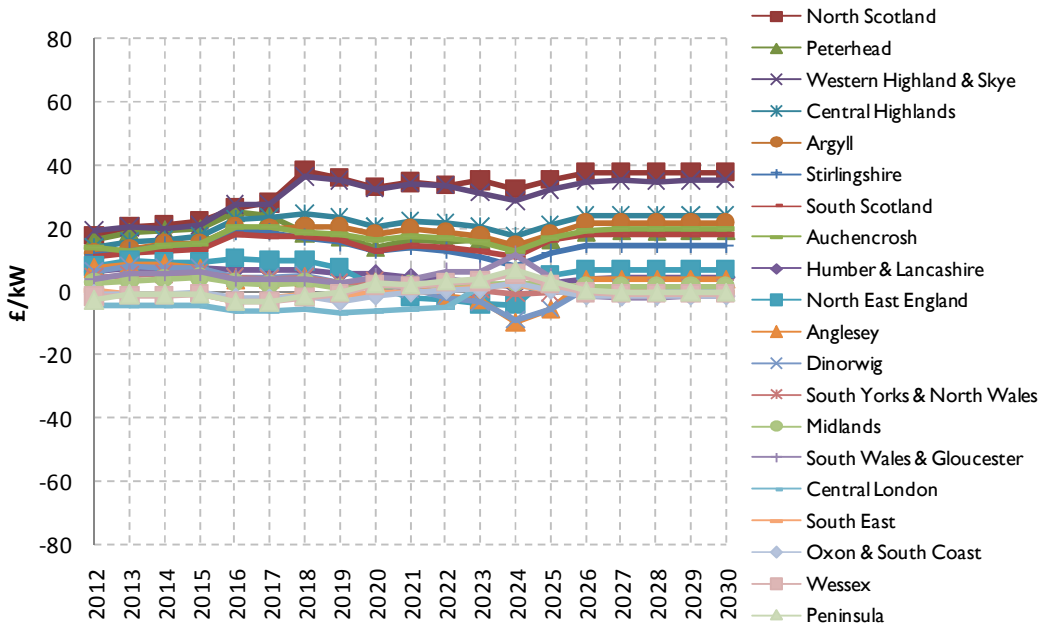
**Figure A15.41 – Illustrative wider generation tariffs by zone:  
Diversity 1**

### Conventional generation (30% Annual Load Factor)



**Figure A15.42 – Illustrative wider generation tariffs by zone:  
Diversity 1**

### Conventional generation (70% Annual Load Factor)



**Figure A15.43 – Illustrative wider generation tariffs by zone:  
Diversity 1**

### Intermittent generation (30% Annual Load Factor)

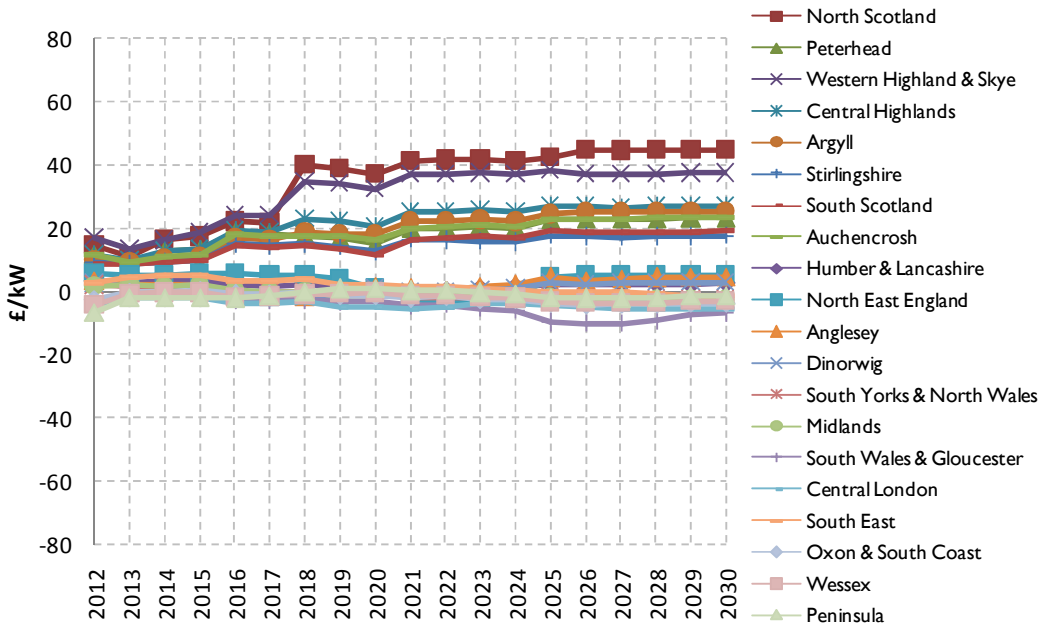


Figure A15.44 – Illustrative wider generation tariffs by zone: Diversity 2

### Conventional generation (30% Annual Load Factor)

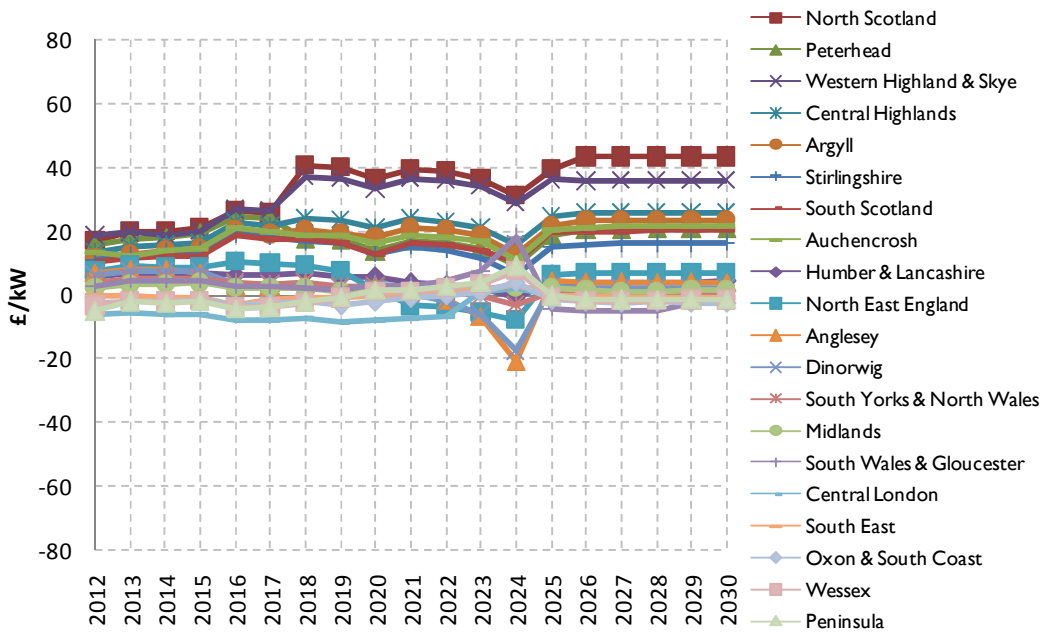
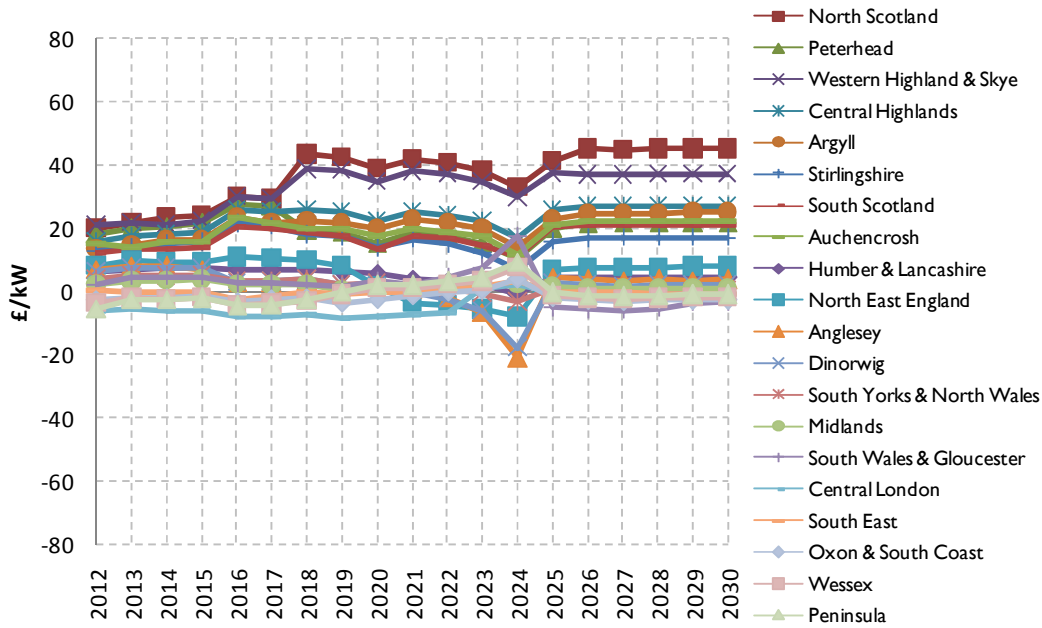
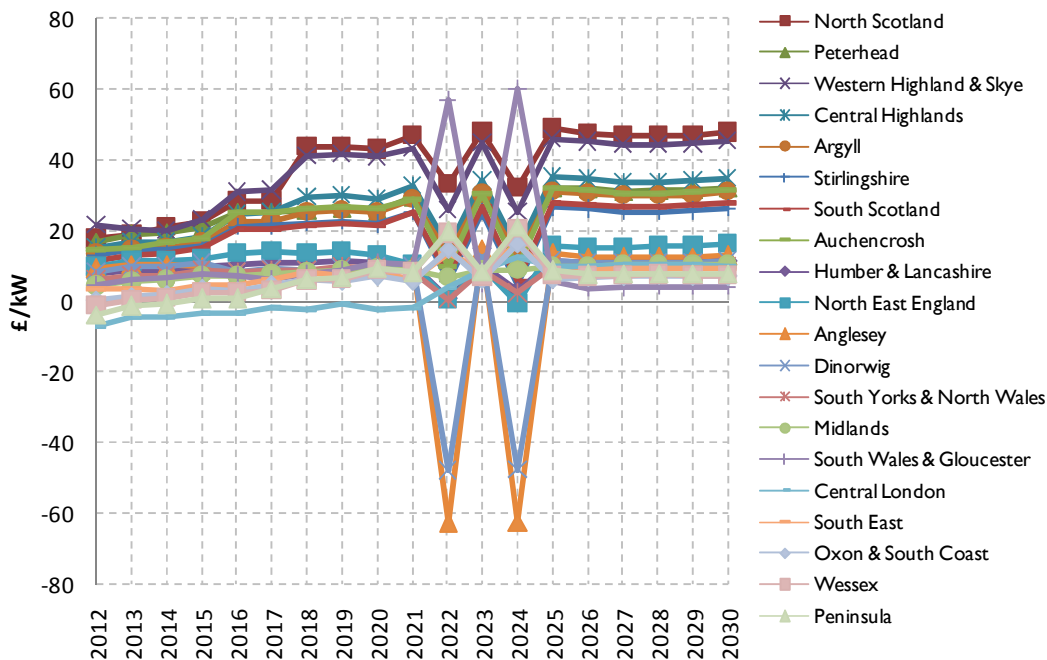


Figure A15.45 – Illustrative wider generation tariffs by zone: Diversity 2

### Conventional generation (70% Annual Load Factor)



**Figure A15.46 – Illustrative wider generation tariffs by zone:  
Diversity 2**



**Figure A15.47 – Illustrative wider generation tariffs by zone:  
Diversity 3**

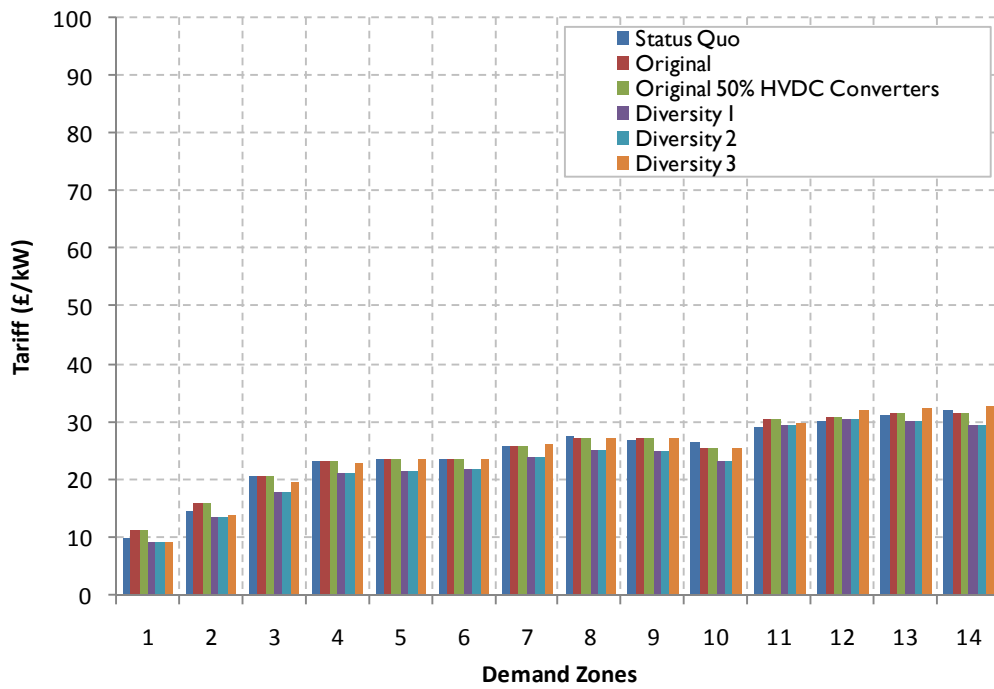


Figure A15.48 – 2012 illustrative HH Demand tariffs

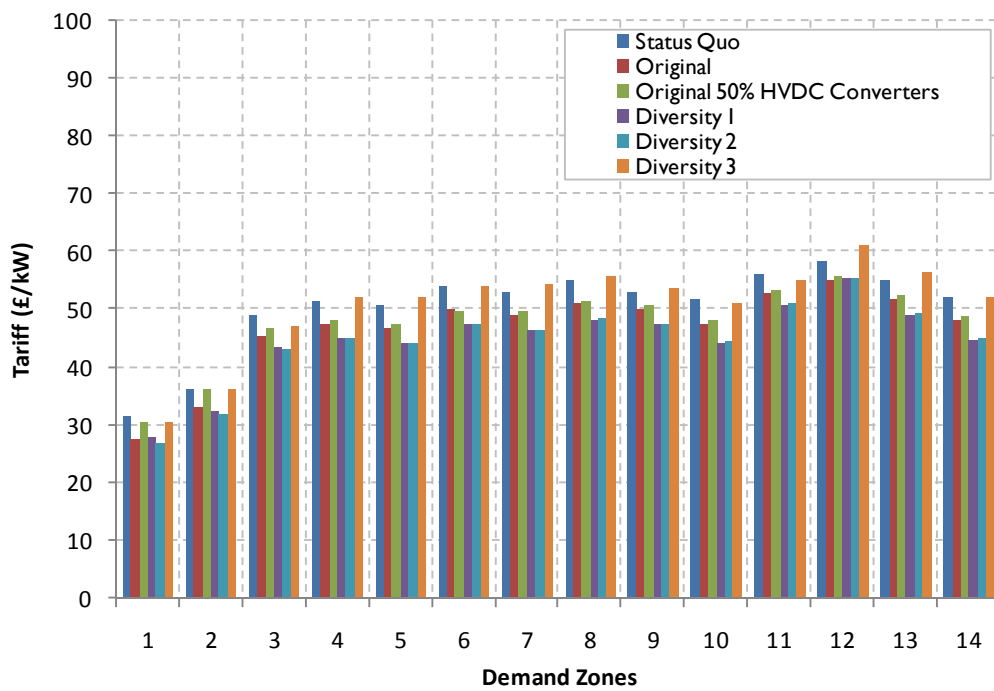


Figure A15.49 – 2020 illustrative HH Demand tariffs



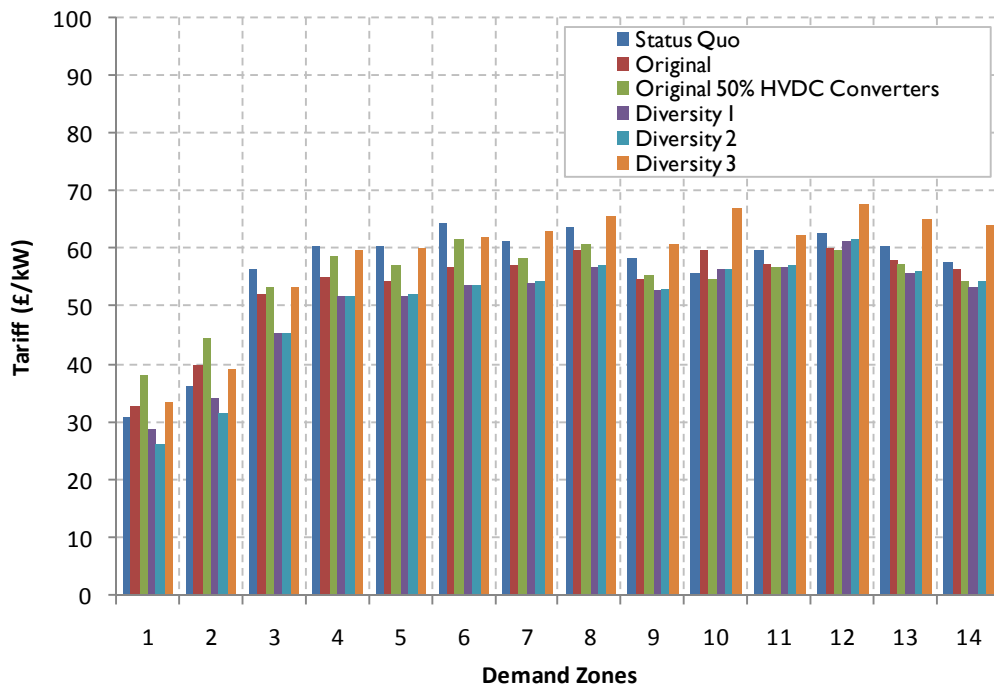


Figure A15.50 – 2030 illustrative HH Demand tariffs

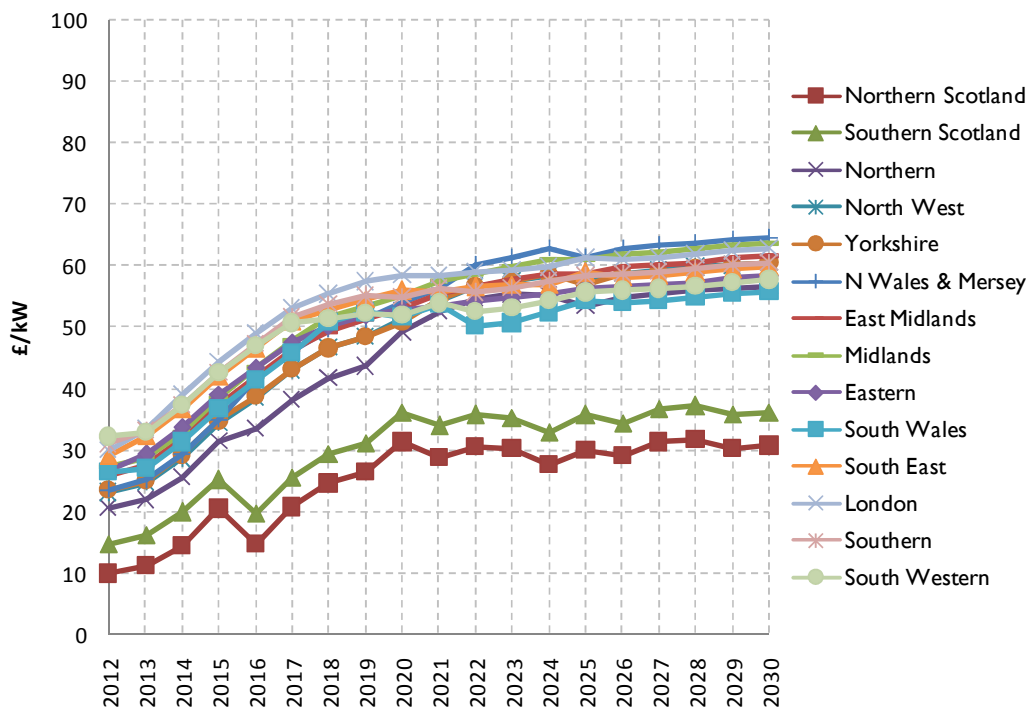
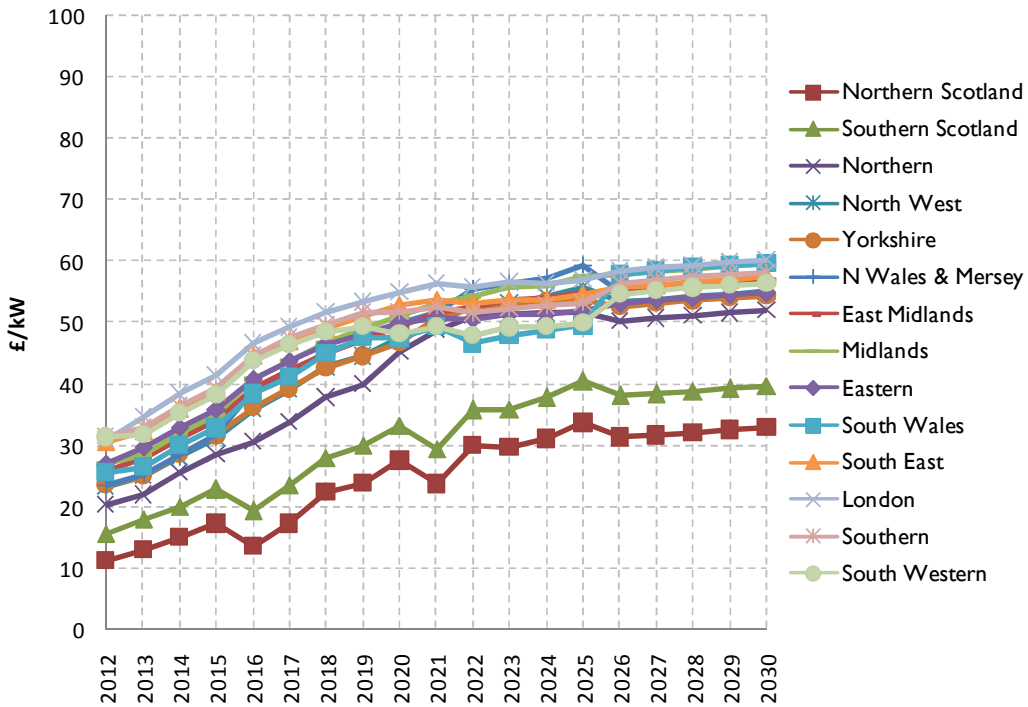
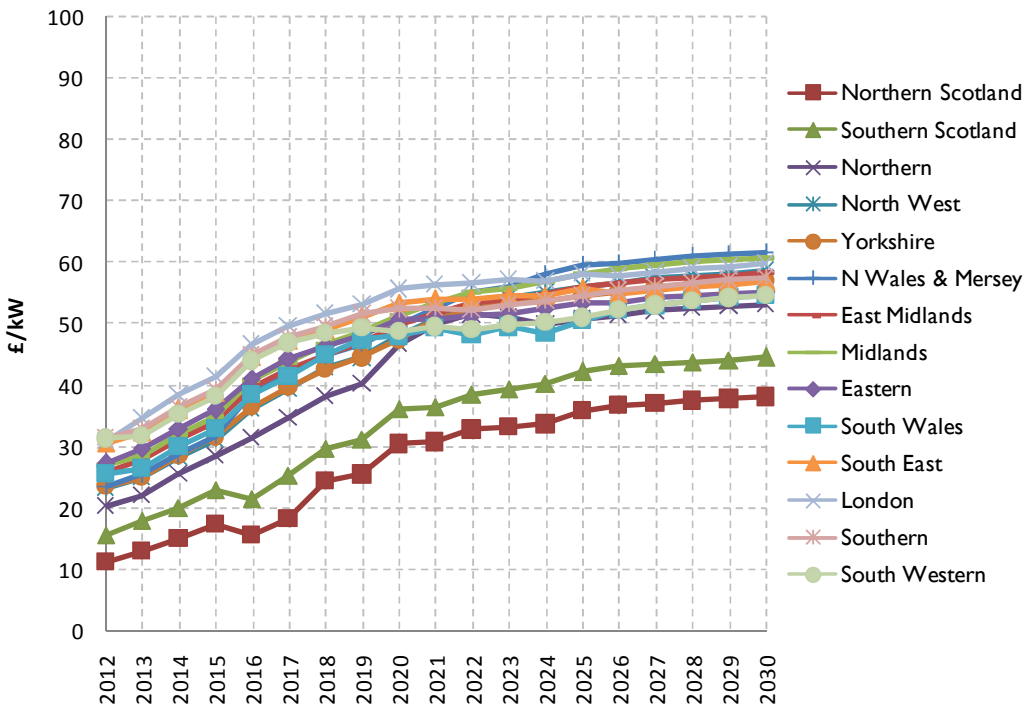


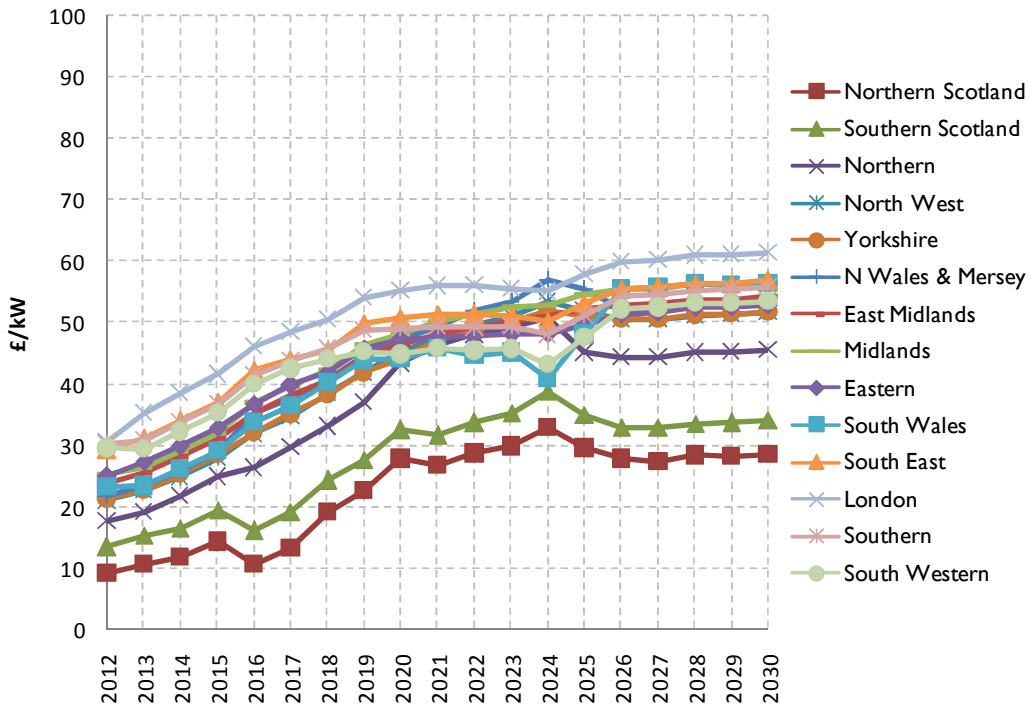
Figure A15.51 – Illustrative HH Demand tariffs by zone: Status Quo



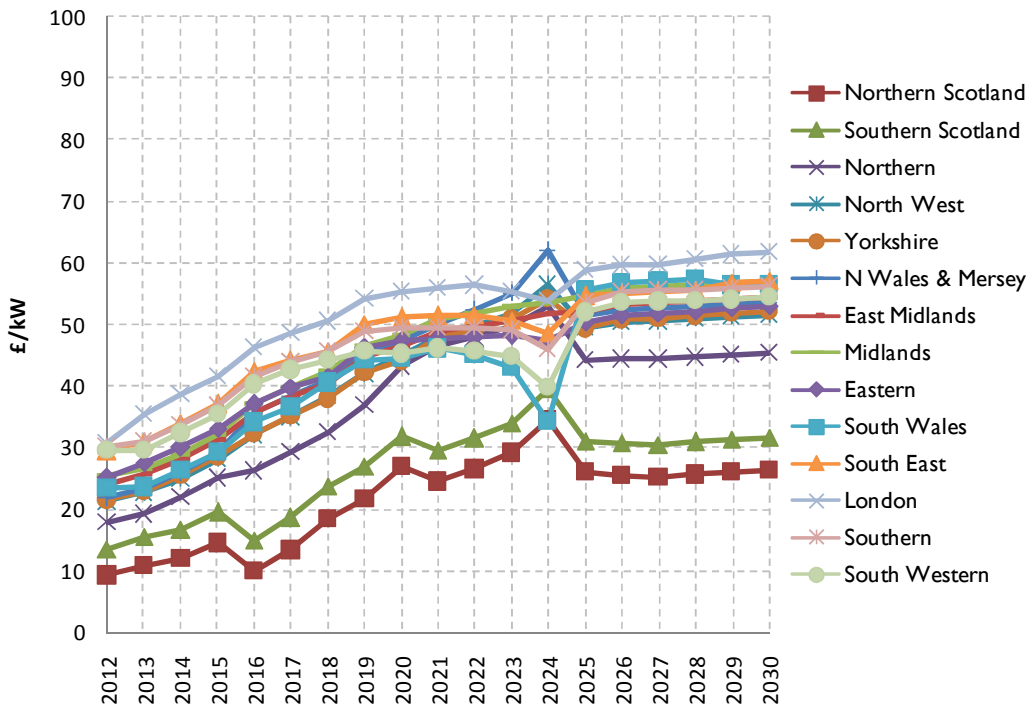
**Figure A15.52 – Illustrative HH Demand tariffs by zone:  
Original proposal**



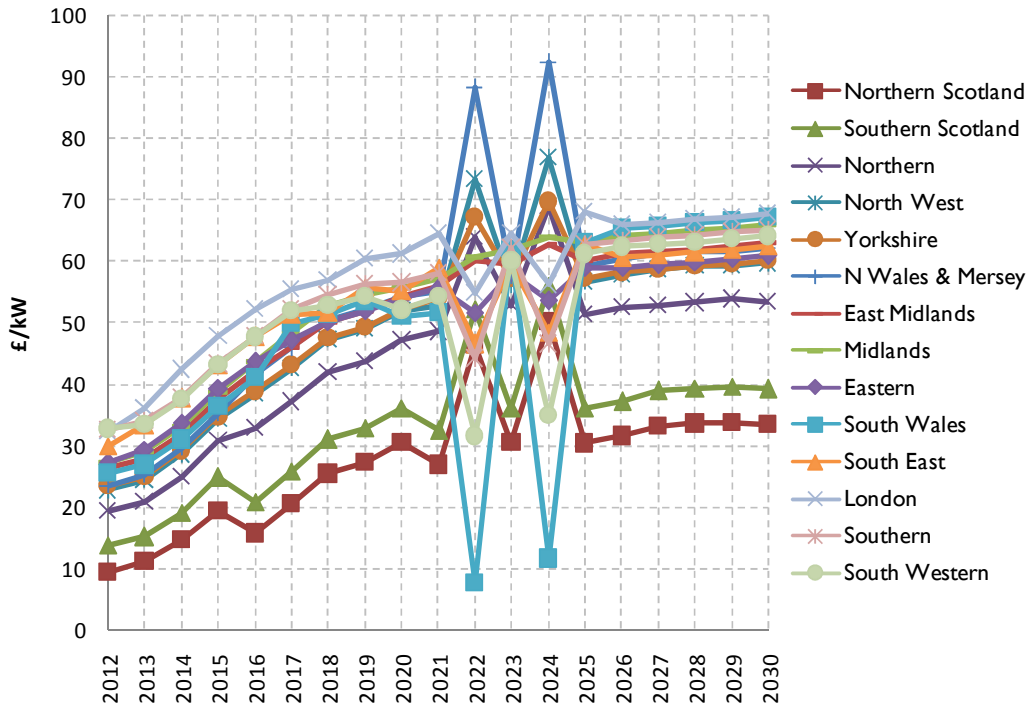
**Figure A15.53 – Illustrative HH Demand tariffs by zone:  
Original 50% HVDC Converters**



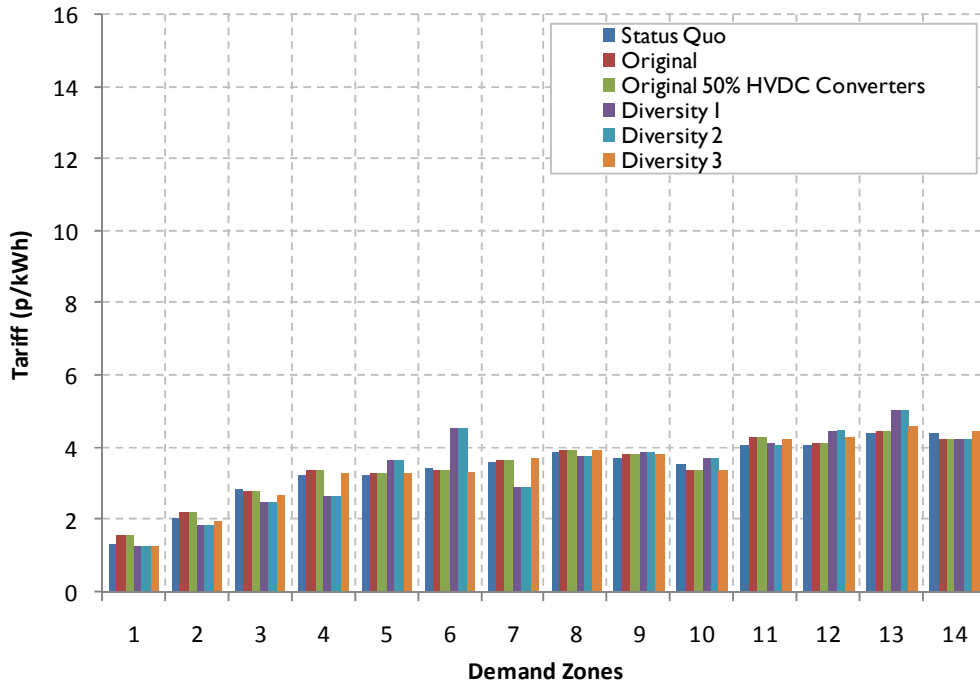
**Figure A15.54 – Illustrative HH Demand tariffs by zone:  
Diversity 1**



**Figure A15.55 – Illustrative HH Demand tariffs by zone:  
Diversity 2**



**Figure A15.56 – Illustrative HH Demand tariffs by zone:  
Diversity 3**



**Figure A15.57 – 2012 illustrative NHH Demand tariffs**

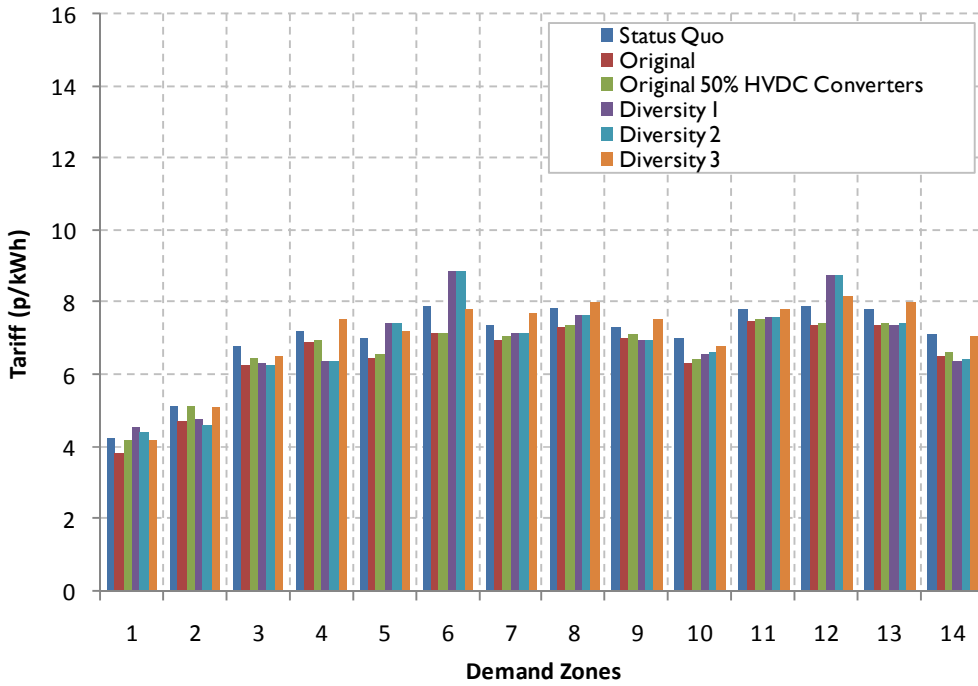


Figure A15.58 – 2020 illustrative NHH Demand tariffs

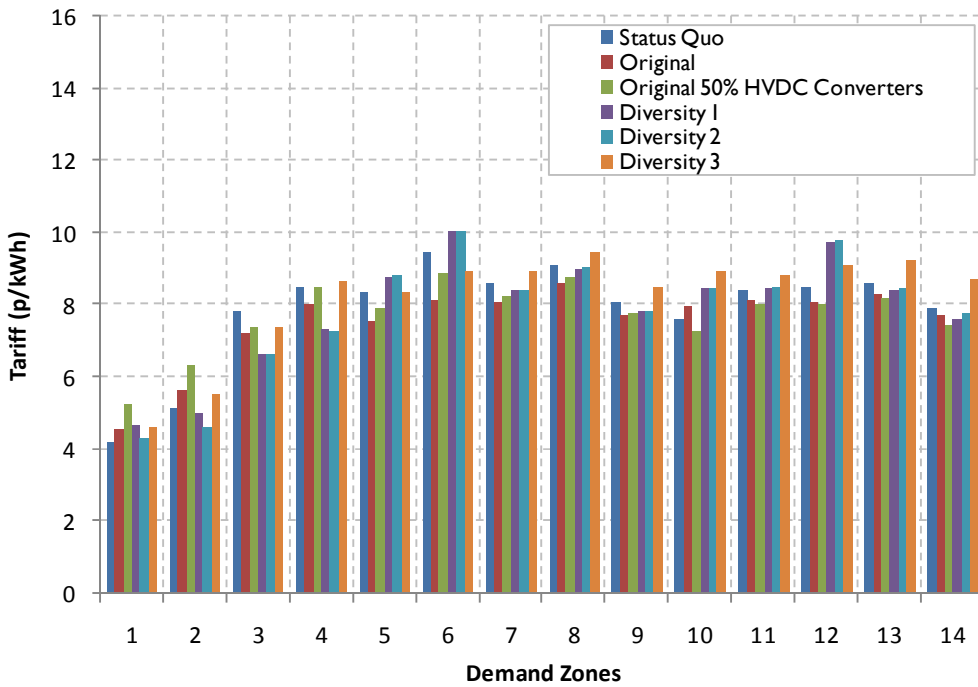
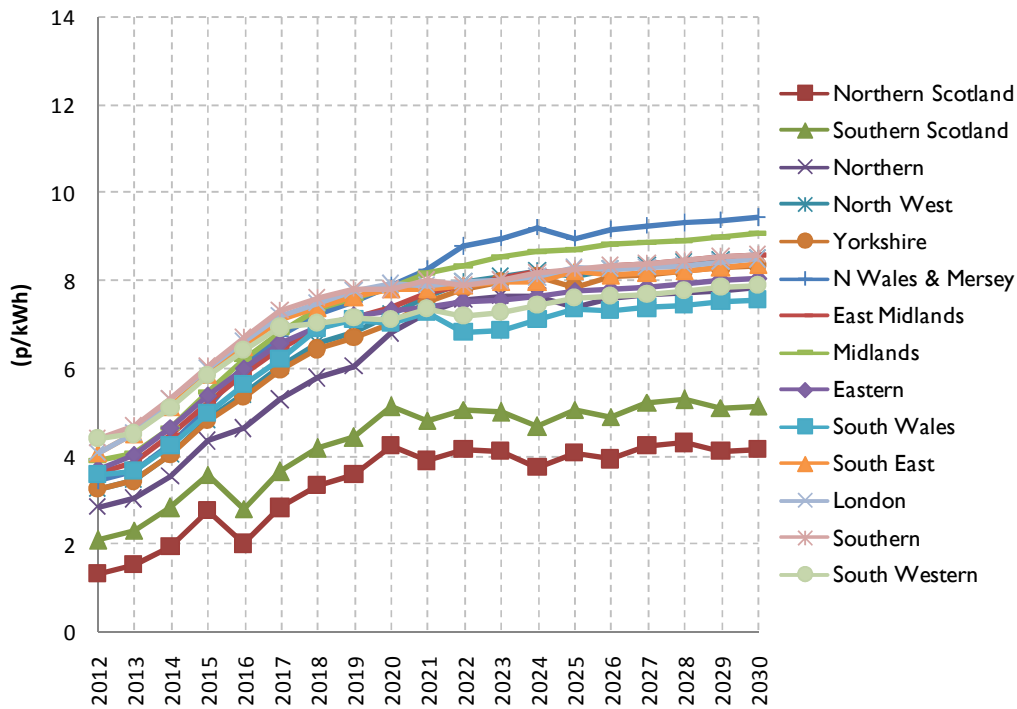
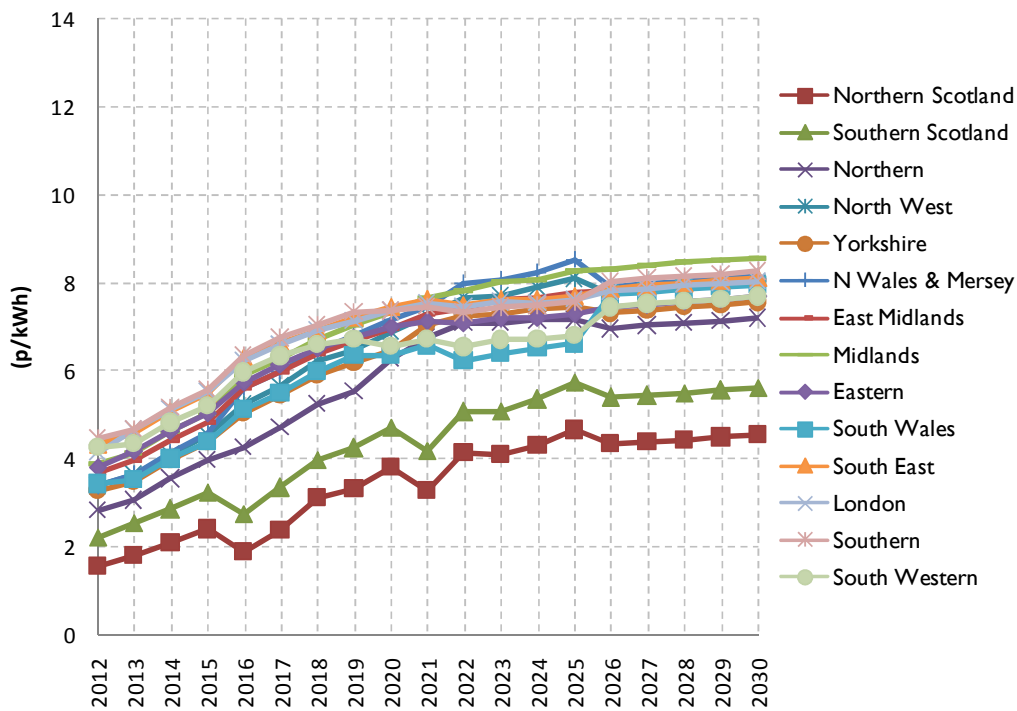


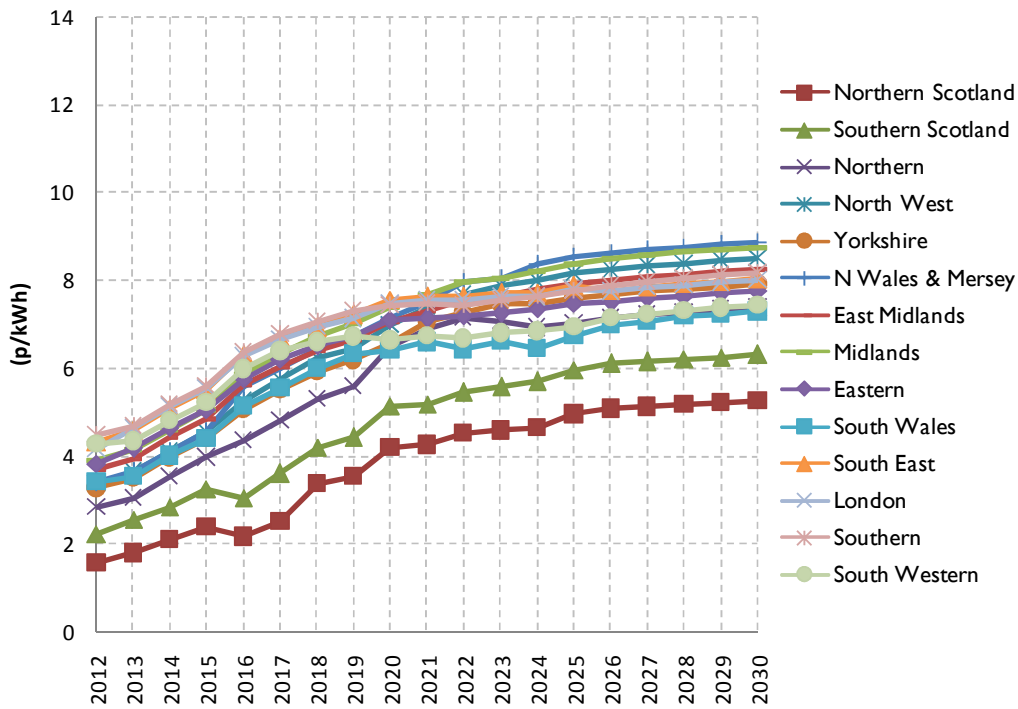
Figure A15.59 – 2030 illustrative NHH Demand tariffs



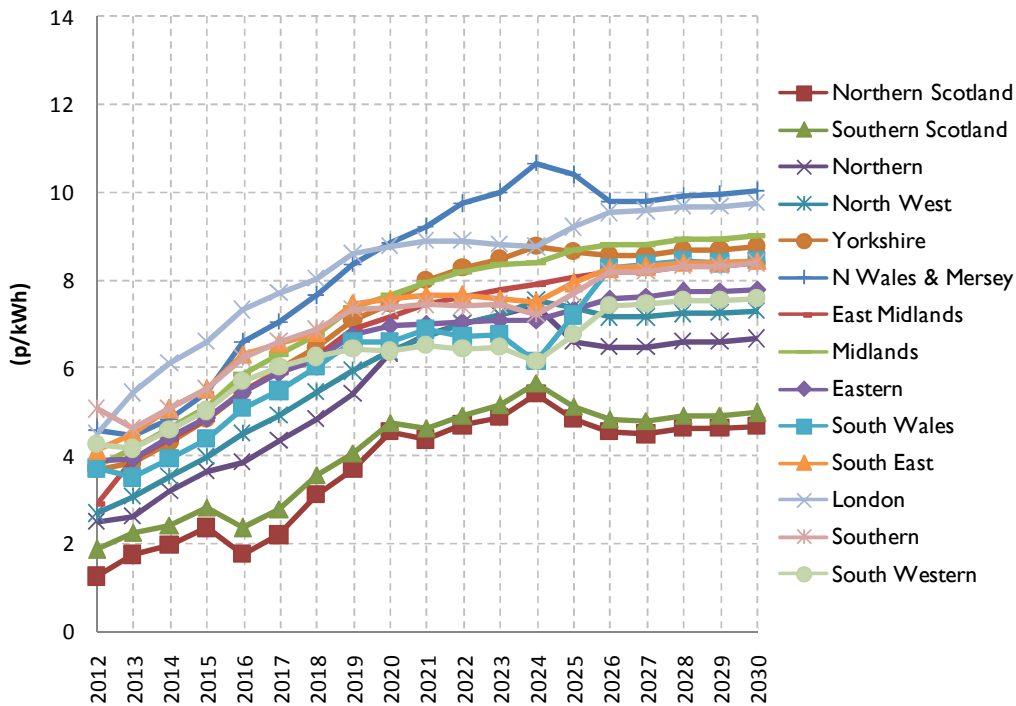
**Figure A15.60 – Illustrative NHH Demand tariffs by zone:  
Status Quo**



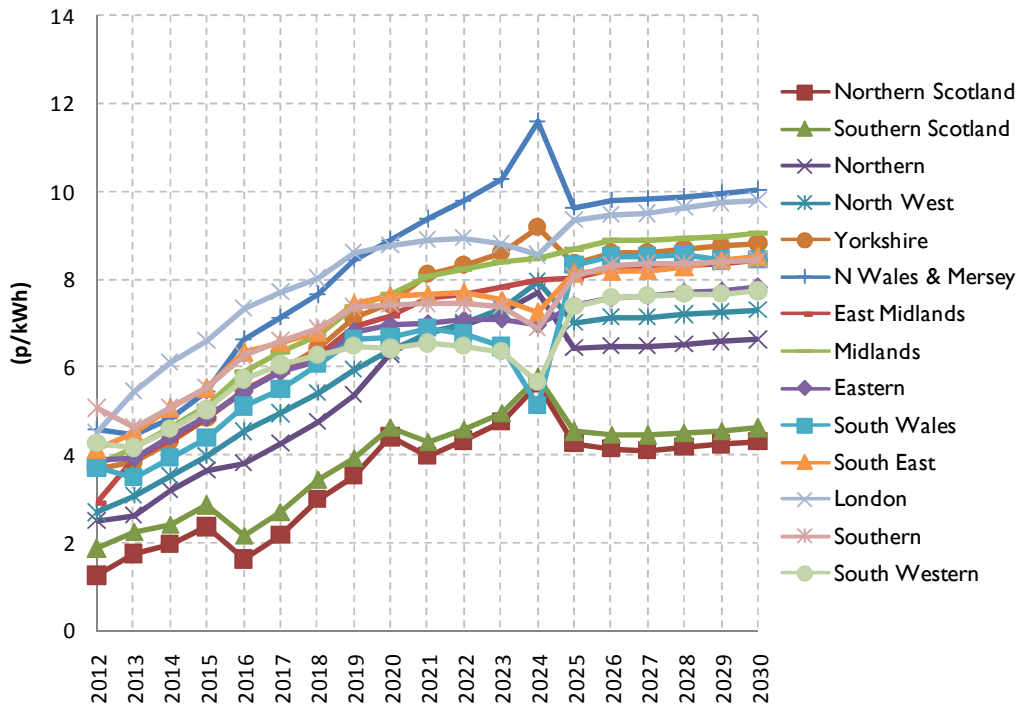
**Figure A15.61 – Illustrative NHH Demand tariffs by zone:  
Original proposal**



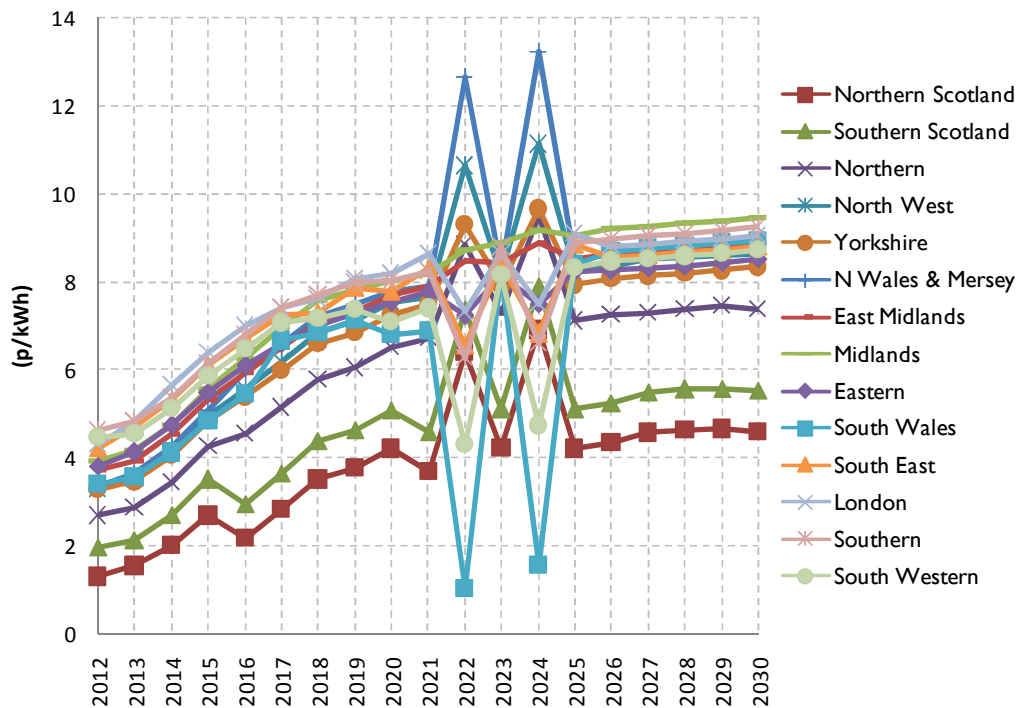
**Figure A15.62 – Illustrative NHH Demand tariffs by zone:  
Original 50% HVDC Converters**



**Figure A15.63 – Illustrative NHH Demand tariffs by zone:  
Diversity 1**



**Figure A15.64 – Illustrative NHH Demand tariffs by zone:  
Diversity 2**



**Figure A15.65 – Illustrative NHH Demand tariffs by zone:  
Diversity 3**



## Annex 16 – Results of the Workgroup vote on WACMs

The contents of this Appendix contain a summary of Workgroup voting on Workgroup Alternative CUSC Modification (WACM) proposals and include:

- Summary of views from Workgroup members regarding potential alternative elements
- Summary of voting on potential alternative elements

### Summary of views from Workgroup members regarding potential alternative elements

WG member	Sharing - Original and Diversity options	Form of Sharing – use of Annual Load Factor	HVDC & Islands	Other (general comments)
<b>Summary of potential alternative elements options</b>	<p><i>Extent of sharing</i></p> <ul style="list-style-type: none"> <li>• <i>Original (no diversity)</i></li> <li>• <i>Diversity method 1</i></li> <li>• <i>Diversity method 2</i></li> <li>• <i>Diversity method 3</i></li> </ul>	<p><i>Method of calculating ALF</i></p> <ul style="list-style-type: none"> <li>• <i>Historic ALF</i></li> <li>• <i>Hybrid ALF</i></li> </ul>	<p><i>% of Converter costs used in the Expansion Factor</i></p> <ul style="list-style-type: none"> <li>• <i>100% Convertors</i></li> <li>• <i>50% Generic (AC)</i></li> <li>• <i>40% (links) / 30% (Islands) Generic (AC &amp; QB / VSC convertors)</i></li> <li>• <i>Specific (AC)</i></li> </ul>	
<b>Andy Wainwright</b>	<ul style="list-style-type: none"> <li>• Original more simple and transparent for users.</li> <li>• Diversity 1 slightly stronger on cost reflectivity (better on CUSC objective B) but slightly worse than Original on objective A (as complexity slightly worse for competition).</li> <li>• Slight preference for Diversity 1 but that and Original balance in</li> </ul>	<ul style="list-style-type: none"> <li>• Preference for historic ALF.</li> <li>• Hybrid less cost reflective as doesn't take a long term view of load factor. Also adds complexity and therefore costs for Users and NGET (worse under CUSC objective A).</li> </ul>	<ul style="list-style-type: none"> <li>• See merit in 100%.</li> <li>• Argument for removing a proportion for consistency with onshore AC – out of these AC generic 50% best.</li> <li>• Not convinced by arguments for QB cost removal.</li> <li>• Doesn't believe enough evidence for VSC converter element.</li> <li>• Specific good idea but not</li> </ul>	

WG member	Sharing - Original and Diversity options	Form of Sharing – use of Annual Load Factor	HVDC & Islands	Other (general comments)
	terms of simplicity vs. cost reflectivity.		practical – weighed down by complexity.	
<b>Dennis Gowland</b>	<ul style="list-style-type: none"> <li>• Original more cost reflective. Imperfect but reflects a balance between cost reflectivity and simplicity. Fairer overall.</li> <li>• Out of Diversity options, 1 is preferred as allows 100% sharing as a max.</li> <li>• Not convinced by justification for 50% “cap” in diversity methods 2 &amp; 3.</li> </ul>	<ul style="list-style-type: none"> <li>• ALF relationship as proxy itself imperfect.</li> <li>• Out of 2 methods, prefers the historic ALF.</li> </ul>	<ul style="list-style-type: none"> <li>• Reduce convertor costs for AC equivalents, QBs and VSC convertors by generic percentages (40% HVDC / 30% Islands).</li> <li>• Difficult to get obtain information for specific factors therefore generic figures to be used.</li> </ul>	<ul style="list-style-type: none"> <li>• Ideally, full CBA would be used to determine charges but this is not practical.</li> </ul>
<b>Peter Waghorn</b>	<ul style="list-style-type: none"> <li>• Original useful as it introduces main concepts.</li> <li>• Diversity options preferred.</li> <li>• Diversity 3 preferred on basis it is simple, limits sharing to 50% and uses a single background (believes dual background demand security approach is inappropriate).</li> </ul>	<ul style="list-style-type: none"> <li>• ALF as proposed is not a representative proxy for network usage, future generation running and transmission network investment.</li> <li>• Out of ALF options, preference for Hybrid.</li> </ul>	<ul style="list-style-type: none"> <li>• Including 100% of costs not appropriate as this does not compare with treatment of AC assets.</li> <li>• Reduce convertor costs for AC equivalents, QBs and VSC convertors by generic percentages (40% HVDC / 30% Islands).</li> <li>• Specific cost removal not appropriate due to difficulties retrieving information.</li> </ul>	<ul style="list-style-type: none"> <li>• Major issues with all 3 elements of Original proposal – not supportive overall. On sharing, fundamentally disagrees with ALF.</li> </ul>
<b>Garth Graham</b>	<ul style="list-style-type: none"> <li>• Original best meets applicable CUSC objectives A, B and C regarding sharing, better reflecting the changes in the transmission business and facilitating competition..</li> <li>• Diversity 1 – neutral on CUSC</li> </ul>	<ul style="list-style-type: none"> <li>• Historic ALF better against CUSC objectives A and B as reflects better Users cost impacts in terms of their use of the transmission system.</li> <li>• Hybrid ALF also better (for the same reasons), but further</li> </ul>	<ul style="list-style-type: none"> <li>• 100% inappropriate as doesn't acknowledge AC equivalent benefits of convertor station costs (worse against CUSC objectives A &amp; B).</li> <li>• Reduced convertor station costs for AC equivalents, QBs and VSC</li> </ul>	

WG member	Sharing - Original and Diversity options	Form of Sharing – use of Annual Load Factor	HVDC & Islands	Other (general comments)
	<p>objective B and worse on objective A (complexity, and potential to discrimination which is detrimental to competition).</p> <ul style="list-style-type: none"> <li>Diversity 2 and 3 are worse against CUSC objectives A and B (complexity, and potential to discrimination which is detrimental to competition).</li> </ul>	<p>improvements under objective A as also has user forecast element allowing users to use their own information, which is better for competition.</p>	<p>convertors by generic percentages (40% HVDC / 30% Islands) is better against CUSC objectives A &amp; B as they reflect the AC equivalent benefits.</p>	
<b>James Anderson</b>	<ul style="list-style-type: none"> <li>Original goes some way to reflect use of system and assumptions made under GSR009.</li> <li>On balance prefers Original in terms of simplicity.</li> <li>Diversity 1 better recognises impact of load factor but complexity outweighs better cost reflectivity benefits.</li> <li>Diversity 2 and 3 not an adequate reflection of sharing on the transmission system, does not agree with 50% “cap”.</li> </ul>	<ul style="list-style-type: none"> <li>Preference for hybrid ALF. Some things happen in a generator’s life cycle that are one offs and which can’t be predicted (impacts of legislation etc.). Waiting for this to be reflected in a 5 year average isn’t fully cost reflective.</li> </ul>	<ul style="list-style-type: none"> <li>Significant body of evidence presented to reduce convertor costs for AC equivalents, QBs and VSC convertors by generic percentages (40% HVDC / 30% Islands).</li> </ul>	<ul style="list-style-type: none"> <li>All options better reflect CUSC objective C; SQSS assumptions have changed, also HVDC technology is coming and is not reflected in the current methodology.</li> </ul>
<b>Mark Cox</b>	<ul style="list-style-type: none"> <li>General support for sharing under the Original.</li> <li>Support any diversity alternatives in terms of increased cost reflectivity.</li> </ul>	<ul style="list-style-type: none"> <li>Historic ALF best. But can see arguments for hybrid due to upcoming period of unprecedented change in the energy market environment .</li> </ul>	<ul style="list-style-type: none"> <li>100% of convertor costs should remain in the calculation as the assets have been installed for the benefit of that particular technology (locational rather than wider), therefore keep all costs in.</li> </ul>	<ul style="list-style-type: none"> <li>Concern around modelling and being able to confirm the impact of what the diversity methods do so very keen to digest numbers further.</li> </ul>
<b>Simon Lord</b>	<ul style="list-style-type: none"> <li>Sharing in the Original a good start.</li> <li>However, important to take into</li> </ul>	<ul style="list-style-type: none"> <li>Annual Load Factor not seen as suitable proxy for transmission network investment.</li> </ul>	<ul style="list-style-type: none"> <li>Preference for specific approach as ensures most cost reflective choice is made.</li> </ul>	

WG member	Sharing - Original and Diversity options	Form of Sharing – use of Annual Load Factor	HVDC & Islands	Other (general comments)
	<p>account Load Factor, bid price and correlation together. Original doesn't take into account this complexity sufficiently and doesn't reflect reality.</p> <ul style="list-style-type: none"> <li>• Merits in all diversity options.</li> <li>• Diversity 1 is good movement forwards compared to Original. However, issues with areas dominated by carbon.</li> <li>• Diversity 2 and 3 are an improvement.</li> <li>• Diversity 3 best as it does reflect area wide issue rather than basing assumptions on individual generator's Load Factor.</li> </ul>	<ul style="list-style-type: none"> <li>• Indifferent between hybrid and historic options for calculating ALF, slight preference for hybrid option.</li> </ul>	<ul style="list-style-type: none"> <li>• Support 50% generic (AC).</li> <li>• Believes 40%/30% option acceptable for first HVDC links but should be reassessed thereafter.</li> <li>• Sees argument for 100% due to parallel with offshore.</li> </ul>	
<b>Frank Prashad</b>	<ul style="list-style-type: none"> <li>• Does not support original, diversity 1 or diversity 2 as does not believe Load Factor is a proxy for transmission network investment, prefers the current methodologies with its implicit sharing.</li> <li>• Out of the three diversity options, method 3 is the best as attempts to reflect user characteristics within an area as a whole. However, would like to consider in more detail how other factors which influence transmission investments is represented in this</li> </ul>	<ul style="list-style-type: none"> <li>• Doesn't believe ALF a suitable proxy. To reflect User characteristics need to take into account more factors, including running times, locations and demand as a combination of these factors drive network investment.</li> </ul>	<ul style="list-style-type: none"> <li>• Support 100%</li> <li>• If removing costs from the expansion factor is considered, it should be explicitly codified. The benefit should then be reflected in the SO Operational regime and parties should be able to see benefit realised year on year.</li> </ul>	<ul style="list-style-type: none"> <li>• If we are to move away from single background, more analysis is required. Does not believe the year round background is representative of the full conditions arising during a year.</li> <li>• Disagrees with calculating impedance over multiple boundaries for parallel links as the number of boundaries can be arbitrarily chosen. Believes this is completely arbitrary</li> </ul>

WG member	Sharing - Original and Diversity options	Form of Sharing – use of Annual Load Factor	HVDC & Islands	Other (general comments)
	method.			<p>and seriously flawed.</p> <ul style="list-style-type: none"> <li>In calculating the Tariffs, a distributed reference Node is chosen. This is an arbitrary decision and in effect allows a choice to recover varying proportions of the revenue from the Peak and Year round backgrounds.</li> </ul>
<b>Ebba John</b>	<ul style="list-style-type: none"> <li>Original and all diversity methods better reflect CUSC objective C.</li> <li>However, concern about increasing complexity with sharing and its impact on competition (CUSC objective A), therefore prefers status quo (no sharing).</li> <li>Out of sharing options, preference for diversity 1 &amp; diversity 2.</li> </ul>	<ul style="list-style-type: none"> <li>Historic ALF preferred, hybrid overly-complex.</li> </ul>	<ul style="list-style-type: none"> <li>100% not appropriate.</li> <li>Specific removal best option as evidence base for generic insufficient. Doesn't believe specific would be too onerous to calculate.</li> </ul>	
<b>Ricky Hill</b>	<ul style="list-style-type: none"> <li>Does not believe Load Factor is cost reflective without diversity and therefore does not support Original. Also believes it is worse under CUSC objective C.</li> <li>Diversity 1 - improvement on Original, but discriminatory (as unequal treatment of Low Carbon/Carbon)</li> <li>Diversity 2 &amp; 3 – better than Original as non discriminatory and</li> </ul>	<ul style="list-style-type: none"> <li>Historic is not accurate reflector of use of system.</li> <li>Hybrid likely to better reflect current or better user needs.</li> </ul>	<ul style="list-style-type: none"> <li>Preference for 100%.</li> <li>Strong arguments been made for including some elements on basis that this mirrors onshore equivalents but this is nebulous and difficult to quantify.</li> <li>Generic reductions aren't cost reflective.</li> </ul>	

WG member	Sharing - Original and Diversity options	Form of Sharing – use of Annual Load Factor	HVDC & Islands	Other (general comments)
	<p>demonstrates better the drivers of transmission investment.</p> <ul style="list-style-type: none"> <li>• Prefers status quo (no sharing).</li> </ul>			
<b>Cem Suleyman</b>	<ul style="list-style-type: none"> <li>• Original not as cost reflective on sharing as doesn't take into account other factors i.e. diversity. The Load factor/congestion cost relationship proposed is too simplistic</li> <li>• Out of the diversity options, diversity 3 is best as it does not use an ALF scaling factor, which introduces extra complexity into the wholesale market. It also treats Low Carbon and Carbon plant equivalently</li> <li>• At present, have a slight overall preference for the status quo (no sharing)</li> </ul>	<ul style="list-style-type: none"> <li>• ALF scaling factor introduces unnecessary complexity into short run wholesale pricing decisions.</li> <li>• Nevertheless, historic is less bad than hybrid owing to the additional administrative complexity/cost associated with the hybrid approach.</li> </ul>	<ul style="list-style-type: none"> <li>• Specific converter cost (AC) removal preferred to as it better ensures equivalence with onshore and offshore charging. Evidence base for generic cost removal is inadequate.</li> </ul>	<ul style="list-style-type: none"> <li>• Would like more time to analyse modelling results (as such, views are based on underlying theories and concepts), if this was the case may have a preference for Alternative 25.</li> <li>• Would have liked an alternative which incorporates a Status Quo sharing option combined with specific converter cost (AC) HVDC option.</li> </ul>
<b>Paul Jones</b>	<ul style="list-style-type: none"> <li>• Unsupportive of sharing options but more supportive of diversity than original.</li> <li>• Does not believe there is a confirmed link between load factor and investment decisions. Bid price and diversity is also important.</li> <li>• Concern about the signal being sent to generators and the behaviour it is seeking to change</li> </ul>	<ul style="list-style-type: none"> <li>• Unsupportive of historic as feedback loop with behaviour change not established.</li> <li>• Prefers hybrid.</li> </ul>	<ul style="list-style-type: none"> <li>• 100% is fully consistent with offshore.</li> <li>• However, believes there is some evidence for removal of costs that would be socialised for AC substations – specific is best and more consistent with specific approach for offshore.</li> <li>• Generic proportions options are based on one off evidence, unlikely to be representative and</li> </ul>	

WG member	Sharing - Original and Diversity options	Form of Sharing – use of Annual Load Factor	HVDC & Islands	Other (general comments)
	by using ALF.		are most different to the approach used for offshore (discriminatory).	
<b>Maf Smith</b>	<ul style="list-style-type: none"> <li>Sharing – ALF important, strong evidence base for this.</li> <li>Original, balances transparency and simplicity</li> <li>Support for Diversity options.</li> <li>Concerns with diversity 2 and 3 due to 50% “cap”.</li> <li>Diversity 3 not supported as doesn’t use Load Factor</li> </ul>	<ul style="list-style-type: none"> <li>Supportive of historic but understand concerns.</li> </ul>	<ul style="list-style-type: none"> <li>Support Original on basis that this codifies treatment of HVDC technology.</li> <li>However, sees some evidence for removal of convertor station costs as strongest argument.</li> </ul>	<ul style="list-style-type: none"> <li>Concerns about variability of charges and importance of predictability.</li> </ul>
<b>Helen Snodin</b>	<ul style="list-style-type: none"> <li>Original – believes a strong evidence base for using ALF.</li> <li>Diversity options– sees impact in principle, but too many assumptions in complex and changing environment</li> <li>Out of the diversity options, prefers Diversity 1. Improvement on baseline but not over sharing in the Original</li> <li>Sees 50% “cap” in diversity 2 and 3 as arbitrary and not evidenced.</li> </ul>	<ul style="list-style-type: none"> <li>Historic transparent and practical.</li> <li>Hybrid less practical but sees why some would prefer.</li> </ul>	<ul style="list-style-type: none"> <li>100% inequitable with onshore.</li> <li>Removing costs creates better parity.</li> <li>Specific option is impractical as hard to obtain costs.</li> </ul>	
<b>Patrick Smart</b>	<ul style="list-style-type: none"> <li>Best reflection of User impact on investment decisions, whilst minimising complexity &amp; volatility.</li> <li>Diversity 1 better reflective of generator use than status quo, however, concerns around volatility (and impact on competition).</li> </ul>	<ul style="list-style-type: none"> <li>Preference for historic as simple, transparent and reflects User’s impact.</li> <li>Hybrid has potential for gaming.</li> </ul>	<ul style="list-style-type: none"> <li>100% inconsistent with onshore.</li> <li>Best option to reduce convertor costs for AC equivalents, QBs and VSC convertors by generic percentages (40% HVDC / 30% Islands).</li> </ul>	

WG member	Sharing - Original and Diversity options	Form of Sharing – use of Annual Load Factor	HVDC & Islands	Other (general comments)
	<ul style="list-style-type: none"> <li data-bbox="421 331 792 419">Diversity 2 and 3 – strong concerns over volatility and impact on competition.</li> </ul>			



Summary of voting on potential alternative elements

Main Components of CMP213	Original	1	2	3	4	5	6	7	8	9	10	11	12	13	14	15	16	17	18	19	20	21	22	23	24	25	26	27	28	29	30	31	32	33	34	35	36	37	38	39	40	41							
No Diversity	x	x						x	x						x	x						x	x						x	x						x	x												
Diversity Method 1			x			x				x			x				x			x				x			x				x			x											x			x	
Diversity Method 2				x			x				x		x					x			x				x			x				x			x				x			x							
Diversity Method 3					x							x							x							x							x														x		
YR - ALF historic specific (5 years)	x		x	x				x		x	x				x		x	x				x		x	x				x		x	x				x		x	x										
YR - Hybrid		x				x	x		x				x	x		x				x	x		x				x	x		x				x	x		x										x	x	
Specific EF 100% Conv+100%Cable (original)	x	x	x	x	x	x	x																																										
Specific EF; generic 40% Conv+100%Cable (AC sub + QB)								x	x	x	x	x	x	x	x	x	x	x	x	x	x																												
Specific EF; generic 50% Conv+100%Cable (AC sub)																																																	
Specific EF; specific x% Conv. cost reduction (AC sub)																						x	x	x	x	x	x	x																					
Islands																																																	
Specific EF 100% Conv+100%Cable (original)	x	x	x	x	x	x	x																																										
Specific EF; generic 30% Conv+100%Cable (AC sub + STATCOM)								x	x	x	x	x	x	x																													x	x	x	x	x	x	x
Specific EF; generic 50% Conv+100%Cable (AC sub)															x	x	x	x	x	x	x								x	x	x	x	x	x	x														
Specific EF; specific x% specific Conv. cost reduction (AC sub)																													x	x	x	x	x	x	x														
Either original or baseline		8	12	10	7	11	10	8	7	8	5	2	8	5	7	7	7	4	2	8	5	10	9	11	8	4	10	7	8	7	9	6	4	9	6	7	7	7	4	2	8	5							
Chairman perogative - retain as WACM					Yes										Yes		Yes	Yes	Yes								Yes					Yes	Yes																
Vote: Better than baseline	8	7	9	6	3	8	5	7	7			7		7		7	4	2	6		7	7	8	5	2	8		7		8	6	3	8															7	
Vote: Better than Original	N/A	2	6	5	6	4	6	7	4			5		6		4	1	2	5		9	8	7	5	4	7		8		7	3	3	7															6	

## Annex 17 – Illustrative TNUoS Charges for Island Developments

The following is a summary of the tariff elements that comprise the overall TNUoS charge for a prospective island developer.

### Wider zonal tariff

This is comprised of locational and non-locational elements. If island connections are deemed to be part of the wider transmission system, then the cost of an island link will be reflected in this component via an appropriate expansion factor, which could result in the island being in a separate charging zone. If island links are deemed to be local circuits rather than wider, islands would connect into the nearest mainland zone which on the 2013/14 zones all island connections would connect into generation charging zone 1. The 2013/14 tariff for this zone is £25.42/kW. Whilst CMP213 is proposing changes to the wider methodology which will affect this figure, it will affect all generators within this charging zone on the same basis. If significant reinforcements take place (e.g. an HVDC bootstrap reinforcement) affecting the wider transmission system around zone 1 then, in line with the process for generation re-zoning, there may be a potential for zone 1's configuration to alter which would affect the wider tariff for generators within zone 1.

### Local substation tariff

This is a global figure which depends on the substation rating, connection type, and connection voltage of the substation the generator connects into. 2013/14 figures are provided below.

Substation Rating	Connection Type	Local Substation Tariff (£/kW)		
		132kV	275kV	400kV
<1320 MW	No redundancy	0.170	0.097	0.070
<1320 MW	Redundancy	0.375	0.232	0.169
>=1320 MW	No redundancy	-	0.305	0.221
>=1320 MW	Redundancy	-	0.501	0.366

### Local circuit tariff

This is a circuit specific tariff reflecting the cost of the local circuit used by a generator to reach the nearest main interconnected transmission system (MITS) node. If island links are deemed to be local then the island links costs will be reflected in TNUoS charges as part of the local circuit tariff. This is consistent with the CMP213 original proposal.

#### (i) Cross island connections

It should be noted that, in addition to the cost of the island link, there is also a tariff element representing the traditional onshore technology costs for connecting a

generator to the island HVDC hub. These are calculated from local expansion factors. 2013/14 values are presented in the table below for 132kV circuits are differing construction types.

<b>Circuit Construction</b>	<b>132kV OHL Expansion Factor</b>
Single (<200MVA)	10.331
Double (<200MVA)	8.388
Single(>=200MVA)	5.912
Double(>=200MVA)	3.950
Cable	22.58

The calculation of the local circuit tariff is as follows;

Local circuit tariff (£/kW) = expansion factor x expansion constant x security factor x length of circuit /1000

The expansion constant for 2013/14 is £12.51/MWkm. The security factor is either 1.8 if there is redundancy, or 1.0 if no redundancy.

So for a generator connected via a local circuit of less than 200MVA capacity consisting of 30km single circuit 132kV overhead line with no redundancy, the local circuit tariff would be £3.87/kW.

## **(ii) Island Links**

CMP213 is currently considering, as part of the proposal, the treatment of island transmission connections comprised of sub-sea technology within the TNUoS charging methodology. All options under consideration calculate a specific expansion factor calculated for each link which, assuming the island link is treated as a local circuit for charging purposes, would then be used as above to calculate part of the overall local circuit tariff<sup>44</sup>.

The tables below show, in 2012/13 prices, illustrative local circuit tariffs for the island links and the expansion factors that would be used in their calculation. These are based on a 2011 ODIS information<sup>45</sup> and discussions with SHE-T. The CMP213 alternatives involving the treatment of converter costs have been included and are

<sup>44</sup> It should be noted that all proposals currently allow for a counter correlation factor (“CCF”) to account for conditions where a TO has intentionally built a reduced capacity of transmission relative to the amount of generation to account for counter-correlation of output of differing generation technologies. This would apply to all radial links (i.e. not just island links). A CCF of 1 has been assumed in the examples, and would be applied as a multiplier to the expansion factor of the relevant circuit whether wider or local.

<sup>45</sup> <http://www.nationalgrid.com/NR/rdonlyres/26AE1FA4-2C3B-4895-BC0B-7B2EF0229BFE/49226/Part5AppendixD.pdf>

subject to future change. For Shetland these costs include costs of the local connection to the Caithness mainland only.

Original	Western Isles	Shetland	Orkney AC	Orkney HVDC
Local Circuit Tariff	102.51	71.04	42.96	54.34
Expansion factor	53.95	19.64	48.32	37.18
50% converters	Western Isles	Shetland	Orkney AC	Orkney HVDC
Local Circuit Tariff	82.48	63.53	42.96	39.32
Expansion factor	43.41	17.56	48.32	26.90
30% converters	Western Isles	Shetland	Orkney AC	Orkney HVDC
Local Circuit Tariff	74.46	60.52	42.96	33.31
Expansion factor	39.19	16.73	48.32	22.79