

JUNE 2016

nationalgrid

Electricity Balancing Significant Code Review

Project Lessons
Learned Report



South1 OVERVIEW SUMMARY

Item	Actual	Error	Unit	Return
Prog	22100	21000	-300	470
Wind	15000	15300	+300	780
South1	0	0	+0	601
SWP-20	0	0	+0	301
USM-15	1210	1110	-110	115
USM-14	700	1030	+330	63
Pump S	38800	39750	+950	69
Total Cost				1412

SOUTH1 DISPATCH ADVICE (DISP)

Item	Ins	PM	1300	1330	1340	1350	1400	1410
E RATS-1	439	439	398	470				
E RATS-2	0	0	0	0				
E RATS-3	0	0	0	0				
E RATS-4	479	480						
E IWPS-1	0	0						
E IWPS-2	0	0						
E RUSPS-4	485	488						
E RUSPS-7	463	468						
E DEMA-1	66	62/C	62					

Stack (SEL)

Item	Actual	1300	1325	1340
USM-14	C	86/12	63/19	
SWP-19	C	65/12	60/19	
SWP-20	C	290/00	300/00	
DIDCS6	C	606/0	700/0	
DIDCS6	C	507/116	510/117	
DWC-1	C	548/140	510/180	487/180

South1 Bid/offer Price Stack (SEL)

Item	DISP	1300	1325	1340	1350	1400	1410
LAGA-1	1400	1400	1400	1400	1400	1400	1400
STAY-3	208	373	415	373	208	165	35.85
USM-15	208	373	415	373	208	165	35.76
USM-14	63	63	115	63	115	104	50.00
STAY-2	208	373	415	373	208	165	35.85
TRFD-1	0	-80	-80	-80	0	0	0.00
STAY-1	208	373	415	373	208	165	35.76
STAY-3	208	373	415	373	208	165	35.76
STAY-1	417	421	422	421	275	784	35.69
STAY-2	470	470	470	470	275	784	35.55
RATS-1	480	480	480	480	275	784	35.51
RATS-2	299	404	404	404	214	1170	35.00
SWP-20	299	404	404	404	214	1170	35.00

Secondary Response

Item	Actual	1300	1325	1340
USM-14	C	86/12	63/19	
SWP-19	C	65/12	60/19	
SWP-20	C	290/00	300/00	
DIDCS6	C	606/0	700/0	
DIDCS6	C	507/116	510/117	
DWC-1	C	548/140	510/180	487/180

Contents



Any Questions?

Contact:
Richard Price



richard.j.price@nationalgrid.com



0118 936 3391

- Contents 2**
- 1. Introduction 3**
- 2. Background to MODIS 4**
- 3. Timelines..... 5**
- 4. What went wrong..... 6**
- 5. What we have included in our review 7**
- 6. Lessons learned and remedial actions 8**
- 7. Outstanding actions..... 11**
- 8. Commitments from National Grid 12**

About this document

This document provides a summary of the lessons learned from National Grid’s internal Electricity Balancing Significant Code Review (EBSCR) Project.

Document Control

Version	Date	Author	Change Reference
1.0	June 2016	National Grid	

1 Introduction

Following OFGEM's Electricity Balancing Significant Code Review (EBSCR) calculation of cash-out prices review in 2014, National Grid raised BSC modification P305 to progress OFGEM's recommendations.

The following recommendations were expected to be implemented ahead of Winter 2015/16 and the EBSCR system go-live date was 5th November 2015:

- A reduction in the Price Average Reference (PAR) and Replacement PAR (RPAR) values to better reflect the marginal cost of balancing energy for a given Settlement Period.
- A single imbalance price using the existing Main Price calculation.
- Introduction of a Reserve Scarcity Price (RSP) function for Short Term Operating Reserve (STOR) actions, to better reflect the prevailing scarcity in the market at the time of their use.
- Introduction of Demand Control actions into the imbalance price, priced at the Value of Lost Load (VoLL), and an imbalance volume correction process to amend participants' positions to account for such actions.

(Please note: the acronym "EBSCR" is used in this report in association with the OFGEM review, the internal National Grid project, and the system used by National Grid to calculate De-rated margins and LOLP. The specific context is made clear each time the acronym is used).

2 Background to MODIS

National Grid made the decision to use the MODIS system (Market Operation Data Interface System) to fulfil part of the requirements for the EBSCR project arising from the OFGEM EBSCR review. MODIS was originally developed to report market data, focusing on provision of data for the European Transparency and REMIT Regulations.

MODIS was developed separately from our control room systems to ensure balancing of the system was not compromised.

MODIS was subsequently extended to calculate and manage new data flows resulting from BSC Modification P305 for De-Rated margins (DRM) and Loss of Load Probabilities (LOLP). As a result the MODIS system evolved into a more complicated system used by multiple users for a variety of purposes. The high level architecture of the system is shown below.

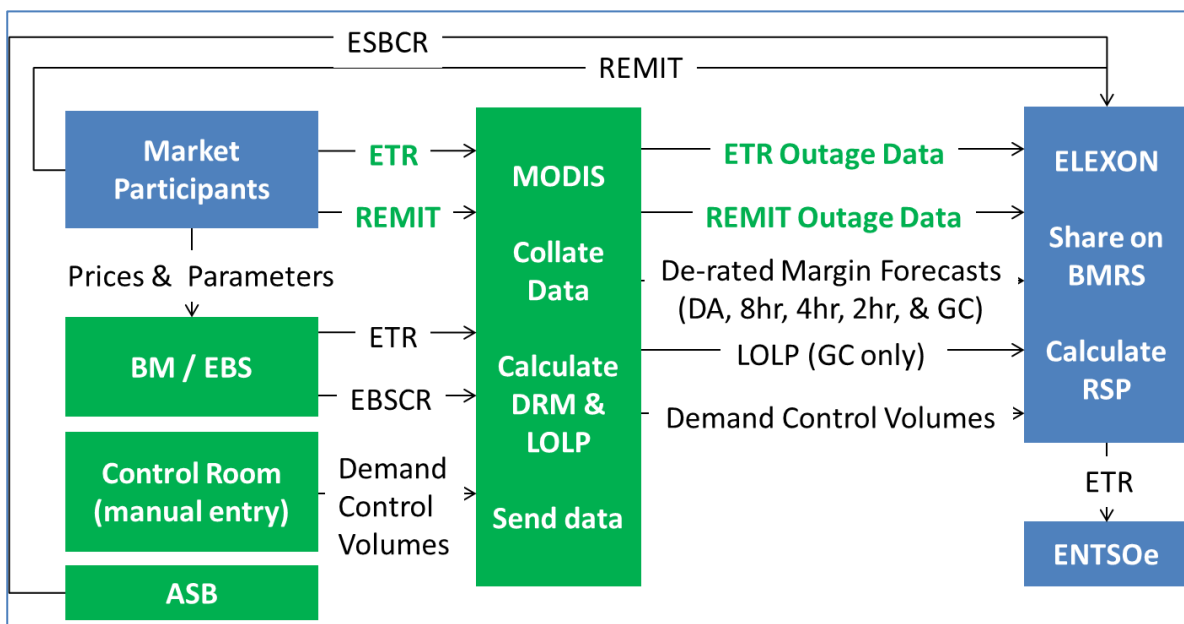

Key:

- BM – National Grid’s Balancing Mechanism system
- EBS – National Grid’s new Electricity Balancing System (replacement for BM)
- EBSCR – Electricity Balancing Significant Code Review data items
- MODIS – Market Operation Data Interface
- RSP – Reserve Scarcity Price
- ETR – European Transparency Regulation
- REMIT – European Regulation on Energy Market Integrity and Transparency
- DRM – De-rated Margin
- LOLP – Loss of Load Probability
- ASB – National Grid’s Ancillary Services Business system
- DA – Day Ahead
- GC – Gate Closure
- BMRS – Balancing Mechanism Reporting System
- ENTSOe – European Network of Transmission System Operators - Electricity

3 Timelines

The following table summarises the key events for P305, EBSCR and the implementation within National Grid’s MODIS system.

Date	Event
May 2014	National Grid asked to raise P304/305 as a result of cashout calculation review.
March 2015	Balancing and Settlement Code modification P305 was agreed.
5 th Nov 2015	EBSCR system go-live - initial teething problems with data availability in the first week.
26 th Nov 2015	Unexpectedly low derated margins
27 th Nov 2015	Missing BMU’s discovered in De-Rated Margin (DRM) calculation – decision taken by National Grid to stop the data feeds to ELEXON
30 th Nov 2015	Accidental Demand Control instructions issued from test system
8 th Dec 2015	Missing BMU’s added into MODIS, erroneous instructions removed and controls put in place; feeds restarted
January - February 2016	Full “drains up” review of EBSCR system implementation – systems , data and calculations
27 th Jan 2016	All feeds suspended after discovery of demand timeshift error
7 th Mar 2016	Feeds restarted after completion of review and correction of demand timeshift error

4 What went wrong

Issues with our EBSCR system resulted in erroneous data being published to the market

a. Missing BMU data in the De-rated Margin (DRM) calculation.

Certain specific BMUs were omitted from the DRM calculation.

Impact: De-rated margins were published which were lower than the actual margins available to National Grid. (note: National Grid has reviewed all the data since go-live, which has now shown that correctly calculated De-rated margins would have resulted in insignificant LOLP values and Reserve Scarcity Prices).

b. Testing issues

A lack of muzzling (preventing test information or scenarios being sent to a production system) and system separation meant that test Demand Control instructions were sent to the live ELEXON system.

Impact: Market Participants were incorrectly alerted by the publication of test instructions on the ELEXON website.

c. Demand timeshift error

Different settlement period time conventions were not correctly mapped between internal National Grid systems

Impact: Calculated margins were incorrect as a component part of the calculation was based on the incorrect half hour.

d. Disaggregated Balancing Services Adjustment Data (BSAD) information

This was originally reported in aggregated format, and the disaggregated reporting was delivered later after the initial P305 / EBSCR release. An issue was found relating to the ramping periods for the STOR instructions. An interim pre-EBS solution was developed to report the central block of MW energy only.

Impact: The timing of Aggregated non-BM STOR volumes was originally not correct within the ramping periods.

5 What we have included in our review

National Grid's objectives when responding to the issues have been to:

- Ensure that the current MODIS system is fully-tested and robust to improve industry confidence Put in place a culture and way of working that ensures we build quality into future developments from the beginning
- Embed excellent engagement with our stakeholders as the norm

Specific actions have been put in place including:

- **A full technical audit by one of our Information Services (IS) partners with Independent and combined Business and IS lessons learned exercises**
- **A drains up review of full EBSCR system functionality (BM and MODIS)**
- **The development of a series of interim and enduring solutions delivered against a corrective action plan**

More details on specific remedial work are provided in the following section.

6 Lessons learned and remedial actions

Our Lessons Learned review consisted of a technical audit of the EBSCR solution and an IT / Business review of the wider project.

The findings from these reviews have been analysed in a manner consistent with ISO 27001 control references. ISO 27001 is concerned with Information Technology, Security Techniques, Information Security, Management Systems and Requirements. The key review recommendations were grouped by Culture and Process, Governance or Core System.

Interim and enduring solutions have been identified with actions being monitored, tracked and reported internally as appropriate.

Specific actions were related to data, testing, resilience, situational alerts, culture, and stakeholder engagement.

6.1 Data

Existing data quality issues (missing units) within BM were translated into incorrect data being transferred by MODIS to BMRS.

Remedial action: A manual process has been implemented to ensure all relevant BMUs are included in the calculation, and post EBS go-live this will be automatic.

6.2 System Access

Inappropriate levels of system access and control were identified.

Remedial action: An Environment manager is now responsible for user access and authorisation for all Production environments. A governance framework and process controls have been put in place to manage user access more securely during and after the project life cycle.

6.3 Testing

The scope, volume and variety of testing were insufficient to fully test all scenarios, including exceptions.

Remedial action: Test data will be analysed for its relevance, variety and completeness by both Business and IS before it is used for testing. For

future developments, we will ensure that further destructive testing cycles are conducted to identify any remaining system exceptions and gaps.

We will also ensure that our IS and Business groups will improve the quality of testing by increasing the strictness in the entry and exit criteria for testing cycles and defining an approach to get test data which is an abstracted version of the real data or a near representation of it.

6.4 Resilience

Resilience has been enhanced since the system went into a hung state, due to a network issue. The application fail-over arrangements were not to a satisfactory level.

Remedial action: An interim fix has been implemented to address this issue. A longer term solution is being investigated.

6.5 Situational Alerts

A lack of monitoring capability in the current application was identified with no auto-alert mechanism for failures, or run-time errors.

Remedial action: A system has been developed to automatically email our application support team and the business whenever there is a failure.

6.6 Culture

The importance and criticality of MODIS and this project were not understood properly.

Remedial action: In future, Business and IS will assess the complexity and criticality of projects together and communicate it accordingly to all project stakeholders.

6.7 Stakeholder engagement

Remedial actions:

We have attended the BSC Panel to explain issues in an open, transparent manner, including a follow-up session at the panel to feedback on lessons learned.

We have improved communication with Ofgem to explain our issues and approaches, and we have held meetings with Elexon to improve how we work together. As part of this, we have been developing communication protocols for industry circulars, and improving planning between our respective IS teams.

We are re-examining our ability to deliver market changes to proposed timetables, with a view to adopting a more realistic approach in future.

We have also held meetings with the Energy UK market committee, IGG and we gave a presentation at the March 2016 Ops Forum on MODIS.

We are committed to engage actively with stakeholders and continue to be open and transparent in our communication with the industry. We are developing an enduring engagement plan.

7 Outstanding actions

A remedial action plan has been created to define interim and enduring solutions to all findings. Initial focus was given to the interim actions within all categories, most notably within the Red and Amber categories, and putting in place a plan to address matters on an enduring basis through appropriate system and process updates.

The majority of all actions have been completed with outstanding actions, shown below, having been prioritised and planned within a timetable agreed with our IS partners and reflective of known MODIS developments associated with the Capacity Mechanism and the migration from the Balancing Mechanism to the new Electricity Balancing System (EBS)

The key actions still outstanding are as follows:

- Our production and Test (UAT) environments for the EBSCR system are to be segregated, which could involve major change to infrastructure or enabling secured controls like firewall between the systems.
- Improvements are being made to the process controls around evaluating a Change Request and accepting its scope and cost-time impacts.
- Both our Business and IS resources will be trained to implement change management more effectively.
- Configurable values for error and warning control limits are to be set, and based on these; exceptions will be triggered to the appropriate team.
- Based on the upcoming requirements and projects in the pipeline, we will evaluate the level of scalability which will be required in MODIS infrastructure and plan the changes accordingly. Multi-application, multi-user access is being considered and enabled for a better user experience, including a single sign-on (SSO).
- We are exploring the feasibility and options associated with dynamically creating the set of BM Units and direct reconciliation with the set of BM Units used by the Control Room for their calculation of margins.

8 Commitments from National Grid

We have identified the following key commitments as a result of our reviews and lessons learned exercises:

- To focus on the quality and resilience of the system
- To set realistic deadlines and work to deliver on time to the right quality
- To provide the same oversight and governance for MODIS as we would for our business critical systems
- To engage actively with stakeholders and to be open and transparent in our communication with the industry