

Our Ref:

Your Ref:

Date: December 2008

To: All Recipients of the Serviced
Grid Code

Regulatory Frameworks
Electricity Codes

National Grid Electricity
Transmission plc
National Grid House
Warwick Technology Park
Gallows Hill
Warwick
CV34 6DA

Tel No: 01926 654971
Fax No: 01926 656601

Dear Sir/Madam

THE SERVICED GRID CODE – ISSUE 3 REVISION 32

Revision 32 of Issue 3 of the Grid Code has been approved by the Authority for implementation on **8th December 2008**.

I have enclosed the replacement pages that incorporate the agreed changes necessary to update the Grid Code Issue 3 to Revision 32 standard.

The enclosed note provides a brief summary of the changes made to the text.

Yours faithfully

Richard Dunn
Electricity Codes



INVESTOR IN PEOPLE

Registered Office:
1-3 Strand
London
WC2N 5EH

Registered in
England and Wales
No 2366977

THE GRID CODE

Issue 3

Revision 32
8th December 2008

Copyright © NATIONAL GRID ELECTRICITY TRANSMISSION plc

No part of this publication may be reproduced, stored in a retrieval system or transmitted in any form or by any means electronic, mechanical, photocopying, recording or otherwise, without written permission.

THIS DOCUMENT IS ISSUED BY:-

**NATIONAL GRID ELECTRICITY TRANSMISSION plc
ELECTRICITY CODES, REGULATORY FRAMEWORKS
NATIONAL GRID HOUSE
WARWICK TECHNOLOGY PARK
GALLOWS HILL
WARWICK
CV34 6DA**

**REGISTERED OFFICE: 1-3 Strand
London
WC2N 5EH**

THE GRID CODE – ISSUE 3 REVISION 32

INCLUSION OF REVISED PAGES

Title Page

Glossary and Definitions

GD - **Pages 11-12**

Planning Code

PC - **Contents Page, Pages 47 to 79**

Connection Conditions

CC - **Contents Pages, Pages 65 to 75**

Balancing Code 3

BC3 - **Pages 5 to 9**

Revisions

- **Page 29**

NOTE:

See Page 1 of the Revisions section of the Grid Code for details of how the revisions are indicated on the pages.

NATIONAL GRID ELECTRICITY TRANSMISSION PLC

THE GRID CODE – ISSUE 3 REVISION 32

SUMMARY OF CHANGES

The changes arise from the implementation of modifications proposed in the following Consultation Paper:

- **D/08** – Grid Code Requirements for Technical Performance

Summary of Proposals

Codification of technical performance requirements which are currently specified in NGET's Guidance Notes. The proposed changes will improve the definition of:

- Performance characteristics required of generating plant (in respect of definition of droop and the operation required when system frequency is above 50.5Hz).
- Operating arrangements if a generator has been required by NGET to fit a power system stabiliser.
- Control system model information required from a generator.

The categories of Users affected by this revision to the Grid Code are:

- Network Operators
- Generators
- Non-Embedded Customers
- DC Converter Station Owners
- Interconnector Users
- Externally Interconnected System Operators

<u>Designed Minimum Operating Level</u>	The output (in whole MW) below which a Genset or a DC Converter at a DC Converter Station (in any of its operating configurations) has no High Frequency Response capability.
<u>De-Synchronise</u>	<p>a) The act of taking a Generating Unit, Power Park Module or DC Converter off a System to which it has been Synchronised, by opening any connecting circuit breaker; or</p> <p>b) The act of ceasing to consume electricity at an importing BM Unit;</p> <p>and the term "De-Synchronising" shall be construed accordingly.</p>
<u>De-synchronised Island(s)</u>	Has the meaning set out in OC9.5.1(a)
<u>Detailed Planning Data</u>	Detailed additional data which NGET requires under the PC in support of Standard Planning Data . Generally it is first supplied once a Bilateral Agreement is entered into.
<u>Discrimination</u>	The quality where a relay or protective system is enabled to pick out and cause to be disconnected only the faulty Apparatus .
<u>Disconnection</u>	The physical separation of Users (or Customers) from the GB Transmission System or a User System as the case may be.
<u>Disputes Resolution Procedure</u>	The procedure described in the CUSC relating to disputes resolution.
<u>Distribution Code</u>	The distribution code required to be drawn up by each Electricity Distribution Licence holder and approved by the Authority , as from time to time revised with the approval of the Authority .
<u>Droop</u>	The ratio of the per unit steady state change in speed, or in Frequency to the per unit steady state change in power output.
<u>Dynamic Parameters</u>	Those parameters listed in Appendix 1 to BC1 under the heading BM Unit Data – Dynamic Parameters .
<u>Earth Fault Factor</u>	At a selected location of a three-phase System (generally the point of installation of equipment) and for a given System configuration, the ratio of the highest root mean square phase-to-earth power Frequency voltage on a sound phase during a fault to earth (affecting one or more phases at any point) to the root mean square phase-to-earth power Frequency voltage which would be obtained at the selected location without the fault.

<u>Earthing</u>	A way of providing a connection between conductors and earth by an Earthing Device which is either: <ul style="list-style-type: none"> (a) Immobilised and Locked in the earthing position. Where the Earthing Device is Locked with a Safety Key, the Safety Key must be secured in a Key Safe and the Key Safe Key must be, where reasonably practicable, given to the authorised site representative of the Requesting Safety Co-Ordinator and is to be retained in safe custody. Where not reasonably practicable the Key Safe Key must be retained by the authorised site representative of the Implementing Safety Co-Ordinator in safe custody: or (b) maintained and/or secured in position by such other method which must be in accordance with the Local Safety Instructions of NGET or the Safety Rules of the Relevant Transmission Licensee or that User, as the case may be.
<u>Earthing Device</u>	A means of providing a connection between a conductor and earth being of adequate strength and capability.
<u>Electrical Standard</u>	A standard listed in the Annex to the General Conditions .
<u>Electricity Council</u>	That body set up under the Electricity Act, 1957.
<u>Electricity Distribution Licence</u>	The licence granted pursuant to Section 6(1) (c) of the Act .
<u>Electricity Supply Industry Arbitration Association</u>	The unincorporated members' club of that name formed inter alia to promote the efficient and economic operation of the procedure for the resolution of disputes within the electricity supply industry by means of arbitration or otherwise in accordance with its arbitration rules.
<u>Electricity Supply Licence</u>	The licence granted pursuant to Section 6(1) (d) of the Act .
<u>Electromagnetic Compatibility Level</u>	Has the meaning set out in Engineering Recommendation G5/4 .
<u>Embedded</u>	Having a direct connection to a User System or the System of any other User to which Customers and/or Power Stations are connected, such connection being either a direct connection or a connection via a busbar of another User or of a Transmission Licensee (but with no other connection to the GB Transmission System).
<u>Embedded Development</u>	Has the meaning set out in PC.4.4.3(a)

PLANNING CODE

CONTENTS

(This contents page does not form part of the Grid Code)

<u>Paragraph No/Title</u>	<u>Page Number</u>
PC.1 INTRODUCTION	3
PC.2 OBJECTIVE.....	4
PC.3 SCOPE	4
PC.4 PLANNING PROCEDURES.....	7
PC.4.2 Introduction to Data	8
PC.4.3 Data Provision	8
PC.4.4 Offer of Terms for connection	9
PC.4.5 Complex Connections	10
PC.5 PLANNING DATA.....	11
PC.6 PLANNING STANDARDS	13
PC.7 PLANNING LIAISON	14
APPENDIX A - PLANNING DATA REQUIREMENTS.....	16
PC.A.1 INTRODUCTION.....	16
PART 1 – STANDARD PLANNING DATA	20
PC.A.2 USER'S SYSTEM DATA.....	20
PC.A.2.1 Introduction	20
PC.A.2.2 User's System Layout	20
PC.A.2.3 Lumped System Susceptance	23
PC.A.2.4 Reactive Compensation Equipment	23
PC.A.2.5 Short Circuit Contribution to GB Transmission System	24
PC.A.3 GENERATING UNIT AND DC CONVERTER DATA	30
PC.A.3.1 Introduction	30
PC.A.3.2 Output Data	31
PC.A.3.3 Rated Parameters Data	35
PC.A.3.4 General Generating Unit, Power Park Module and DC Converter Data	36
PC.A.4 DEMAND AND ACTIVE ENERGY DATA	37

PC.A.4.1	Introduction	37
PC.A.4.2	Demand (Active Power) and Active Energy Data	38
PC.A.4.3	Connection Point Demand (Active and Reactive Power)	40
PC.A.4.5	Post Fault User System Layout	42
PC.A.4.6	Control of Demand or Reduction of Pumping Load Offered as Reserve	42
PC.A.4.7	General Demand Data	43
PART 2 – DETAILED PLANNING DATA		44
PC.A.5	GENERATING UNIT POWER PARK MODULE AND DC CONVERTER DATA.....	44
PC.A.5.1	Introduction	44
PC.A.5.2	Demand	45
PC.A.5.3	Synchronous Generating Unit and Associated Control System Data	46
PC.A.5.4	Non-Synchronous Generating Unit and Associated Control System Data	52
PC.A.5.5	Response data for Frequency changes	58
PC.A.5.6	Mothballed Generating Unit and Alternative Fuel Information	60
PC.A.6	USERS' SYSTEM DATA	63
PC.A.6.1	Introduction	63
PC.A.6.2	Transient Overvoltage Assessment Data	63
PC.A.6.3	User's Protection Data	64
PC.A.6.4	Harmonic Studies	64
PC.A.6.5	Voltage Assessment Studies	65
PC.A.6.6	Short Circuit Analysis	66
PC.A.7	ADDITIONAL DATA FOR NEW TYPES OF POWER STATIONS, DC CONVERTER STATIONS AND CONFIGURATIONS.....	67
PART 3 – NETWORK DATA.....		68
PC.A.8.1	Single Point of Connection	68
PC.A.8.2	Multiple Point of Connection	68
PC.A.8.3	Data Items	68
APPENDIX B		71
	Single Line Diagrams	71
APPENDIX C		74
	PART 1 – SHETL's TECHNICAL AND DESIGN CRITERIA	74
	PART 2 – SPT's TECHNICAL AND DESIGN CRITERIA	76
APPENDIX D		77

Field current (amps) open circuit saturation curve for **Generating Unit** terminal voltages ranging from 50% to 120% of rated value in 10% steps as derived from appropriate manufacturers test certificates.

(b) Parameters for **Generating Unit** Step-up Transformers

- * Rated MVA
- Voltage ratio
- * Positive sequence reactance
(at max, min, & nominal tap)
- Positive sequence resistance
(at max, min, & nominal tap)
- Zero phase sequence reactance
- Tap changer range
- Tap changer step size
- Tap changer type: on load or off circuit

(c) Excitation Control System parameters

Note: The data items requested under Option 1 below may continue to be provided in relation to **Generating Units** on the **System** at 09 January 1995 (in this paragraph, the "relevant date") or the new data items set out under Option 2 may be provided. **Generators** or **Network Operators**, as the case may be, must supply the data as set out under Option 2 (and not those under Option 1) for **Generating Unit** excitation control systems commissioned after the relevant date, those **Generating Unit** excitation control systems recommissioned for any reason such as refurbishment after the relevant date and **Generating Unit** excitation control systems where, as a result of testing or other process, the **Generator** or **Network Operator**, as the case may be, is aware of the data items listed under Option 2 in relation to that **Generating Unit**.

Option 1

DC gain of **Excitation Loop**

- Rated field voltage
- Maximum field voltage
- Minimum field voltage
- Maximum rate of change of field voltage (rising)
- Maximum rate of change of field voltage (falling)

Details of **Excitation Loop** described in block diagram form showing transfer functions of individual elements.
Dynamic characteristics of **Over-excitation Limiter**.
Dynamic characteristics of **Under-excitation Limiter**

Option 2

Excitation System Nominal Response

Rated Field Voltage

No-Load Field Voltage

Excitation System On-Load Positive Ceiling Voltage

Excitation System No-Load Positive Ceiling Voltage

Excitation System No-Load Negative Ceiling Voltage

Details of **Excitation System** (including **PSS** if fitted) described in block diagram form showing transfer functions of individual elements.

Details of **Over-excitation Limiter** described in block diagram form showing transfer functions of individual elements.

Details of **Under-excitation Limiter** described in block diagram form showing transfer functions of individual elements.

The block diagrams submitted after 1 January 2009 in respect of the **Excitation System** (including the **Over-excitation Limiter** and the **Under-excitation Limiter**) for **Generating Units** with a **Completion date** after 1 January 2009 or subject to a **Modification** to the **Excitation System** after 1 January 2009, should have been verified as far as reasonably practicable by simulation studies as representing the expected behaviour of the system.

(d) Governor Parameters

Incremental Droop values (in %) are required for each **Generating Unit** at six MW loading points (MLP1 to MLP6) as detailed in PC.A.5.5.1 (this data item needs only be provided for **Large Power Stations**)

Note: The data items requested under Option 1 below may continue to be provided by **Generators** in relation to **Generating Units** on the **System** at 09 January 1995 (in this paragraph, the "relevant date") or they may provide the new data items set out under Option 2. **Generators** must supply the data as set out under Option 2 (and not those under Option 1) for **Generating Unit** governor control systems commissioned after the relevant date, those **Generating Unit** governor control systems recommissioned for any reason such as refurbishment after the relevant date and **Generating**

Unit governor control systems where, as a result of testing or other process, the **Generator** is aware of the data items listed under Option 2 in relation to that **Generating Unit**.

Option 1

(i) Governor Parameters (for Reheat **Steam Units**)

HP governor average gain MW/Hz
Speeder motor setting range
HP governor valve time constant
HP governor valve opening limits
HP governor valve rate limits
Reheater time constant (**Active Energy** stored in reheater)

IP governor average gain MW/Hz
IP governor setting range
IP governor valve time constant
IP governor valve opening limits
IP governor valve rate limits

Details of acceleration sensitive elements in HP & IP governor loop.
A governor block diagram showing transfer functions of individual elements.

(ii) Governor Parameters (for Non-Reheat **Steam Units** and **Gas Turbine Units**)

Governor average gain
Speeder motor setting range
Time constant of steam or fuel governor valve
Governor valve opening limits
Governor valve rate limits
Time constant of turbine
Governor block diagram

The following data items need only be supplied for **Large Power Stations**:-

(iii) Boiler & Steam Turbine Data

Boiler Time Constant (Stored **Active Energy**)
s

HP turbine response ratio:
proportion of **Primary Response**
%
arising from HP turbine.

HP turbine response ratio:
proportion of **High Frequency Response**
%
arising from HP turbine.

[End of Option 1]

Option 2

(i) Governor and associated prime mover Parameters -
All **Generating Units**

Governor Block Diagram showing transfer function of individual elements including acceleration sensitive elements.

Governor Time Constant (in seconds)

Speeder Motor Setting Range (%)

Average Gain (MW/Hz)

Governor Deadband (this data item need only be provided for **Large Power Stations**)

- Maximum Setting \pm Hz

- Normal Setting \pm Hz

- Minimum Setting \pm Hz

Where the **Generating Unit** governor does not have a selectable deadband facility, then the actual value of the deadband need only be provided.

The block diagrams submitted after 1 January 2009 in respect of the Governor system for **Generating Units** with a **Completion date** after 1 January 2009 or subject to a **Modification** to the governor system after 1 January 2009, should have been verified as far as reasonably practicable by simulation studies as representing the expected behaviour of the system.

(ii) Governor and associated prime mover Parameters -
Steam Units

HP Valve Time Constant (in seconds)

HP Valve Opening Limits (%)

HP Valve Opening Rate Limits (%/second)

HP Valve Closing Rate Limits (%/second)

HP Turbine Time Constant (in seconds)

IP Valve Time Constant (in seconds)

IP Valve Opening Limits (%)

IP Valve Opening Rate Limits (%/second)

IP Valve Closing Rate Limits (%/second)

IP Turbine Time Constant (in seconds)

LP Valve Time Constant (in seconds)

LP Valve Opening Limits (%)

LP Valve Opening Rate Limits (%/second)

LP Valve Closing Rate Limits (%/second)

LP Turbine Time Constant (in seconds)

Reheater Time Constant (in seconds)
Boiler Time Constant (in seconds)
HP Power Fraction (%)
IP Power Fraction (%)

(iii) Governor and associated prime mover Parameters -
Gas Turbine Units

Inlet Guide Vane Time Constant (in seconds)
Inlet Guide Vane Opening Limits (%)
Inlet Guide Vane Opening Rate Limits (%/second)
Inlet Guide Vane Closing Rate Limits (%/second)
Fuel Valve Constant (in seconds)
Fuel Valve Opening Limits (%)
Fuel Valve Opening Rate Limits (%/second)
Fuel Valve Closing Rate Limits (%/second)

Waste Heat Recovery Boiler Time Constant (in seconds)

(iv) Governor and associated prime mover Parameters -
Hydro Generating Units

Guide Vane Actuator Time Constant (in seconds)
Guide Vane Opening Limits (%)
Guide Vane Opening Rate Limits (%/second)
Guide Vane Closing Rate Limits (%/second)
Water Time Constant (in seconds)

[End of Option 2]

(e) Unit Control Options

The following data items need only be supplied with respect to **Large Power Stations**:

Maximum Droop	%
Normal Droop	%
Minimum Droop	%
Maximum Frequency deadband	±Hz
Normal Frequency deadband	±Hz
Minimum Frequency deadband	±Hz
Maximum output deadband	±MW
Normal output deadband	±MW
Minimum output deadband	±MW

Frequency settings between which Unit Load Controller **Droop** applies:

- Maximum Hz
- Normal Hz
- Minimum Hz

State if sustained response is normally selected.

(f) Plant Flexibility Performance

The following data items need only be supplied with respect to **Large Power Stations**, and should be provided with respect to each **Genset**:

- # Run-up rate to **Registered Capacity**,
- # Run-down rate from **Registered Capacity**,
- # **Synchronising Generation**,
Regulating range
Load rejection capability while still **Synchronised** and able to supply **Load**.

Data items marked with a hash (#) should be applicable to a **Genset** which has been **Shutdown** for 48 hours.

- * Data items marked with an asterisk are already requested under part 1, PC.A.3.3.1, to facilitate an early assessment by **NGET** as to whether detailed stability studies will be required before an offer of terms for a **CUSC Contract** can be made. Such data items have been repeated here merely for completeness and need not, of course, be resubmitted unless their values, known or estimated, have changed.

PC.A.5.4 **Non-Synchronous Generating Unit and Associated Control System Data**

PC.A.5.4.1 The data submitted below are not intended to constrain any **Ancillary Services Agreement**

PC.A.5.4.2 The following **Power Park Unit**, **Power Park Module** and **Power Station** data should be supplied in the case of a **Power Park Module** not connected to the **Total System** by a **DC Converter**:

(a) **Power Park Unit** model

A mathematical model of each type of **Power Park Unit** capable of representing its transient and dynamic behaviour under both small and large disturbance conditions. The model shall include non-linear effects and represent all equipment relevant to the dynamic performance of the **Power Park Unit** as agreed with **NGET**. The model shall be suitable for the study of balanced, root mean square, positive phase sequence time-domain behaviour, excluding the effects of electromagnetic transients,

harmonic and sub-harmonic frequencies.

The model shall accurately represent the overall performance of the **Power Park Unit** over its entire operating range including that which is inherent to the **Power Park Unit** and that which is achieved by use of supplementary control systems providing either continuous or stepwise control. Model resolution should be sufficient to accurately represent **Power Park Unit** behaviour both in response to operation of transmission system protection and in the context of longer-term simulations.

The overall structure of the model shall include:

- (i) any supplementary control signal modules not covered by (c), (d) and (e) below.
- (ii) any blocking, deblocking and protective trip features that are part of the **Power Park Unit** (e.g. "crowbar").
- (iii) any other information required to model the **Power Park Unit** behaviour to meet the model functional requirement described above.

The model shall be submitted in the form of a transfer function block diagram and may be accompanied by dynamic and algebraic equations. This model shall display all the transfer functions and their parameter values, any non wind-up logic, signal limits and non-linearities.

The submitted **Power Park Unit** model and the supplementary control signal module models covered by (c), (d) and (e) below shall have been validated and this shall be confirmed by the **Generator**. The validation shall be based on comparing the submitted model simulation results against measured test results. Validation evidence shall also be submitted and this shall include the simulation and measured test results. The latter shall include appropriate short-circuit tests. In the case of an **Embedded Medium Power Station** not subject to a **Bilateral Agreement** the **Network Operator** will provide **NGET** with the validation evidence if requested by **NGET**. The validation of the supplementary control signal module models covered by (c), (d) and (e) below applies only to a **Power Park Module** with a **Completion date** after 1 January 2009.

(b) **Power Park Unit** parameters

- * Rated MVA
- * **Rated MW**
- * Rated terminal voltage
- * Average site air density (kg/m^3), maximum site air density (kg/m^3) and minimum site air density (kg/m^3) for the year
Year for which the air density is submitted
Number of pole pairs
Blade swept area (m^2)
Gear box ratio

Mechanical drive train

For each **Power Park Unit**, details of the parameters of the drive train represented as an equivalent two mass model should be provided. This model should accurately represent the behaviour of the complete drive train for the purposes of power system analysis studies and should include the following data items:-

Equivalent inertia constant (MWsec/MVA) of the first mass (e.g. wind turbine rotor and blades) at minimum, synchronous and rated speeds

Equivalent inertia constant (MWsec/MVA) of the second mass (e.g. generator rotor) at minimum, synchronous and rated speeds

Equivalent shaft stiffness between the two masses (Nm/electrical radian)

Additionally, for **Power Park Units** that are induction generators (e.g. squirrel cage, doubly-fed) driven by wind turbines:

- * Stator resistance
- * Stator reactance
- * Magnetising reactance.
- * Rotor resistance.(at starting)
- * Rotor resistance.(at rated running)
- * Rotor reactance (at starting)
- * Rotor reactance (at rated running)

Additionally for doubly-fed induction generators only:

The generator rotor speed range (minimum and maximum speeds in RPM)

The optimum generator rotor speed versus wind speed submitted in tabular format

Power converter rating (MVA)

The rotor power coefficient (C_p) versus tip speed ratio (λ) curves for a range of blade angles (where applicable) together with the corresponding values submitted in tabular format. The tip speed ratio (λ) is defined as $\Omega R/U$ where Ω is the angular velocity of the rotor, R is the radius of the wind turbine rotor and U is the wind speed.

The electrical power output versus generator rotor speed for a range of wind speeds over the entire operating range of the **Power Park Unit**, together with the corresponding values submitted in tabular format.

The blade angle versus wind speed curve together with the corresponding values submitted in tabular format.

The electrical power output versus wind speed over the entire operating range of the **Power Park Unit**, together

with the corresponding values submitted in tabular format. Transfer function block diagram, including parameters and description of the operation of the power electronic converter and fault ride through capability (where applicable).

For a **Power Park Unit** consisting of a synchronous machine in combination with a back to back **DC Converter**, or for a **Power Park Unit** not driven by a wind turbine, the data to be supplied shall be agreed with **NGET** in accordance with PC.A.7.

- (c) Torque / speed and blade angle control systems and parameters

For the **Power Park Unit**, details of the torque / speed controller and blade angle controller in the case of a wind turbine and power limitation functions (where applicable) described in block diagram form showing transfer functions and parameters of individual elements.

- (d) Voltage/**Reactive Power/Power Factor** control system parameters

For the **Power Park Unit** and **Power Park Module** details of voltage/**Reactive Power/Power Factor** controller (and **PSS** if fitted) described in block diagram form showing transfer functions and parameters of individual elements.

- (e) **Frequency** control system parameters

For the **Power Park Unit** and **Power Park Module** details of the **Frequency** controller described in block diagram form showing transfer functions and parameters of individual elements.

- (f) Protection

Details of settings for the following protection relays (to include): Under **Frequency**, over **Frequency**, under voltage, over voltage, rotor over current, stator over current, high wind speed shut down level.

- (g) Complete **Power Park Unit** model, parameters and controls

An alternative to PC.A.5.4.2 (a), (b), (c), (d), (e) and (f), is the submission of a single complete model that consists of the full information required under PC.A.5.4.2 (a), (b), (c), (d), (e) and (f) provided that all the information required under PC.A.5.4.2 (a), (b), (c), (d), (e) and (f) individually is clearly identifiable.

- (h) Harmonic and flicker parameters

When connecting a **Power Park Module**, it is necessary for **NGET** to evaluate the production of flicker and harmonics on

NGET and User's Systems. At **NGET's** reasonable request, the **User** (a **Network Operator** in the case of an **Embedded Power Park Module** not subject to a **Bilateral Agreement**) is required to submit the following data (as defined in IEC 61400-21 (2001)) for each **Power Park Unit**:-

Flicker coefficient for continuous operation.
Flicker step factor.
Number of switching operations in a 10 minute window.
Number of switching operations in a 2 hour window.
Voltage change factor.
Current Injection at each harmonic for each **Power Park Unit** and for each **Power Park Module**

* Data items marked with an asterisk are already requested under part 1, PC.A.3.3.1, to facilitate an early assessment by **NGET** as to whether detailed stability studies will be required before an offer of terms for a **CUSC Contract** can be made. Such data items have been repeated here merely for completeness and need not, of course, be resubmitted unless their values, known or estimated, have changed.

PC.A.5.4.3

DC Converter

PC.A.5.4.3.1

For a **DC Converter** at a **DC Converter Station** or a **Power Park Module** connected to the **Total System** by a **DC Converter** the following information for each **DC Converter** and **DC Network** should be supplied:

- (a) **DC Converter** parameters
- * **Rated MW** per pole for transfer in each direction;
 - * **DC Converter** type (i.e. current or voltage source);
 - * Number of poles and pole arrangement;
 - * Rated DC voltage/pole (kV);
 - * Return path arrangement;
- (b) **DC Converter** transformer parameters
- Rated MVA
 - Nominal primary voltage (kV);
 - Nominal secondary (converter-side) voltage(s) (kV);
 - Winding and earthing arrangement;
 - Positive phase sequence reactance at minimum, maximum and nominal tap;
 - Positive phase sequence resistance at minimum, maximum and nominal tap;
 - Zero phase sequence reactance;
 - Tap-changer range in %;
 - number of tap-changer steps;
- (c) **DC Network** parameters
- Rated DC voltage per pole;
 - Rated DC current per pole;
 - Single line diagram of the complete **DC Network**;
 - Details of the complete **DC Network**, including resistance,

inductance and capacitance of all DC cables and/or DC lines;
Details of any DC reactors (including DC reactor resistance),
DC capacitors and/or DC-side filters that form part of the **DC Network**;

- (d) AC filter reactive compensation equipment parameters

Note: The data provided pursuant to this paragraph must not include any contribution from reactive compensation plant owned by **NGET**.

Total number of AC filter banks.

Type of equipment (e.g. fixed or variable)

Single line diagram of filter arrangement and connections;

Reactive Power rating for each AC filter bank ,capacitor bank or operating range of each item of reactive compensation equipment, at rated voltage;

Performance chart showing **Reactive Power** capability of the **DC Converter**, as a function of MW transfer, with all filters and reactive compensation plant, belonging to the **DC Converter Station** working correctly.

Note: Details in PC.A.5.4.3.1 are required for each **DC Converter** connected to the **DC Network**, unless each is identical or where the data has already been submitted for an identical **DC Converter** at another **Connection Point**.

Note: For a **Power Park Module** connected to the **Grid Entry point** or (**User System Entry Point** if **Embedded**) by a **DC Converter** the equivalent inertia and fault infeed at the **Power Park Unit** should be given.

DC Converter control system models

PC.A.5.4.3.2

The following data is required by **NGET** to represent **DC Converters** and associated **DC Networks** in dynamic power system simulations, in which the AC power system is typically represented by a positive sequence equivalent. **DC Converters** are represented by simplified equations and are not modeled to switching device level.

- (i) Static V_{DC} - I_{DC} (DC voltage - DC current) characteristics, for both the rectifier and inverter modes for a current source converter. Static V_{DC} - P_{DC} (DC voltage - DC power) characteristics, for both the rectifier and inverter modes for a voltage source converter. Transfer function block diagram including parameters representation of the control systems of each **DC Converter** and of the **DC Converter Station**, for both the rectifier and inverter modes. A suitable model would feature the **DC Converter** firing angle as the output variable.
- (ii) Transfer function block diagram representation including parameters of the **DC Converter** transformer tap changer

control systems, including time delays

- (iii) Transfer function block diagram representation including parameters of AC filter and reactive compensation equipment control systems, including any time delays.
- (iv) Transfer function block diagram representation including parameters of any **Frequency** and/or load control systems.
- (v) Transfer function block diagram representation including parameters of any small signal modulation controls such as power oscillation damping controls or sub-synchronous oscillation damping controls, that have not been submitted as part of the above control system data.
- (vi) Transfer block diagram representation of the **Reactive Power** control at converter ends for a voltage source converter.

Plant Flexibility Performance

PC.A.5.4.3.3 The following information on plant flexibility and performance should be supplied:

- (i) Nominal and maximum (emergency) loading rate with the **DC Converter** in rectifier mode.
- (ii) Nominal and maximum (emergency) loading rate with the **DC Converter** in inverter mode.
- (iii) Maximum recovery time, to 90% of pre-fault loading, following an AC system fault or severe voltage depression.
- (iv) Maximum recovery time, to 90% of pre-fault loading, following a transient **DC Network** fault.

PC.A.5.4.3.4 Harmonic Assessment Information

DC Converter owners shall provide such additional further information as required by **NGET** in order that compliance with CC.6.1.5 can be demonstrated.

- * Data items marked with an asterisk are already requested under part 1, PC.A.3.3.1, to facilitate an early assessment by **NGET** as to whether detailed stability studies will be required before an offer of terms for a **CUSC Contract** can be made. Such data items have been repeated here merely for completeness and need not, of course, be resubmitted unless their values, known or estimated, have changed.

PC.A.5.5 Response data for **Frequency** changes

The information detailed below is required to describe the actual frequency response capability profile as illustrated in Figure CC.A.3.1 of the

Connection Conditions, and need only be provided for each:

- (i) **Genset at Large Power Stations**; and
- (ii) **Generating Unit, Power Park Module or CCGT Module** at a **Medium Power Station** or **DC Converter Station** that has agreed to provide **Frequency** response in accordance with a **CUSC Contract**.

In the case of (ii) above for the rest of this PC.A.5.5 where reference is made to **Gensets**, it shall include such **Generating Units, CCGT Modules, Power Park Modules** and **DC Converters** as appropriate.

In this **PC.A.5.5**, for a **CCGT Module** with more than one **Generating Unit**, the phrase **Minimum Generation** applies to the entire **CCGT Module** operating with all **Generating Units Synchronised** to the **System**. Similarly for a **Power Park Module** with more than one **Power Park Unit**, the phrase **Minimum Generation** applies to the entire **Power Park Module** operating with all **Power Park Units Synchronised** to the **System**.

PC.A.5.5.1 MW loading points at which data is required

Response values are required at six MW loading points (MLP1 to MLP6) for each **Genset**. **Primary** and **Secondary Response** values need not be provided for MW loading points which are below **Minimum Generation**. MLP1 to MLP6 must be provided to the nearest MW.

Prior to the **Genset** being first **Synchronised**, the MW loading points must take the following values :-

MLP1	Designed Minimum Operating Level
MLP2	Minimum Generation
MLP3	70% of Registered Capacity
MLP4	80% of Registered Capacity
MLP5	95% of Registered Capacity
MLP6	Registered Capacity

When data is provided after the **Genset** is first **Synchronised**, the MW loading points may take any value between **Designed Minimum Operating Level** and **Registered Capacity** but the value of the **Designed Minimum Operating Level** must still be provided if it does not form one of the MW loading points.

PC.A.5.5.2 **Primary and Secondary Response to Frequency fall**

Primary and **Secondary Response** values for a -0.5Hz ramp are required at six MW loading points (MLP1 to MLP6) as detailed above

PC.A.5.5.3 **High Frequency Response to Frequency rise**

High Frequency Response values for a +0.5Hz ramp are required at six MW loading points (MLP1 to MLP6) as detailed above.

PC.A.5.6 **Mothballed Generating Unit Mothballed Power Park Module or Mothballed DC Converter at a DC Converter Station and Alternative Fuel Information**

Data identified under this section PC.A.5.6 must be submitted as required under PC.A.1.2 and at **NETG**'s reasonable request.

In the case of **Embedded Medium Power Stations** not subject to a **Bilateral Agreement** and **Embedded DC Converter Stations** not subject to a **Bilateral Agreement**, upon request from **NETG** each **Network Operator** shall provide the information required in PC.A.5.6.1, PC.A.5.6.2, PC.A.5.6.3 and PC.A.5.6.4 on respect of such **Embedded Medium Power Stations** and **Embedded DC Converters Stations** with their **System**.

PC.A.5.6.1 **Mothballed Generating Unit Information**

Generators and **DC Converter Station** owners must supply with respect to each **Mothballed Generating Unit, Mothballed Power Park Module or Mothballed DC Converter at a DC Converter Station** the estimated MW output which could be returned to service within the following time periods from the time that a decision to return was made:

< 1 month;

1-2 months;

2-3 months;

3-6 months;

6-12 months; and

>12 months.

The return to service time should be determined in accordance with **Good Industry Practice** assuming normal working arrangements and normal plant procurement lead times. The MW output values should be the incremental values made available in each time period as further described in the **DRC**.

PC.A.5.6.2 **Generators** and **DC Converter Station** owners must also notify **NETG** of any significant factors which may prevent the **Mothballed Generating Unit, Mothballed Power Park Module or Mothballed DC Converter at a DC Converter Station** achieving the estimated values provided under PC.A.5.6.1 above, excluding factors relating to **Transmission Entry Capacity**.

PC.A.5.6.3 **Alternative Fuel Information**

The following data items must be supplied with respect to each **Generating Unit** whose main fuel is gas.

For each alternative fuel type (if facility installed):

- (a) Alternative fuel type e.g. oil distillate, alternative gas supply
- (b) For the changeover from main to alternative fuel:
- Time to carry out off-line and on-line fuel changeover (minutes).
 - Maximum output following off-line and on-line changeover (MW).
 - Maximum output during on-line fuel changeover (MW).
 - Maximum operating time at full load assuming typical and maximum possible stock levels (hours).
 - Maximum rate of replacement of depleted stocks (MWh electrical/day) on the basis of **Good Industry Practice**.
 - Is changeover to alternative fuel used in normal operating arrangements?
 - Number of successful changeovers carried out in the last **NGET Financial Year** (choice of 0, 1-5, 6-10, 11-20, >20).
- (c) For the changeover back to main fuel:
- Time to carry out off-line and on-line fuel changeover (minutes).
 - Maximum output during on-line fuel changeover (MW).

PC.A.5.6.4 **Generators** must also notify **NGET** of any significant factors and their effects which may prevent the use of alternative fuels achieving the estimated values provided under PC.A.5.6.3 above (e.g. emissions limits, distilled water stocks etc.)

PC.A.5.7 **Black Start Related Information**

Data identified under this section PC.A.5.7 must be submitted as required under PC.A.1.2. This information may also be requested by **NGET** during a **Black Start** and should be provided by **Generators** where reasonably possible. **Generators** in this section PC.A.5.7 means **Generators** only in respect of their **Large Power Stations**.

The following data items/text must be supplied, from each **Generator** to **NGET**, with respect to each **BM Unit** at a **Large Power Station** (excluding the **Generating Units** that are contracted to provide **Black Start Capability, Power Park Modules** or **Generating Units** with an **Intermittent Power Source**);

- (a) Expected time for each **BM Unit** to be **Synchronised** following a **Total Shutdown** or **Partial Shutdown**. The assessment should include the **Power Station's** ability to re-synchronise all **BM Units**, if

all were running immediately prior to the **Total Shutdown** or **Partial Shutdown**. Additionally this should highlight any specific issues (i.e. those that would impact on the **BM Unit's** time to be **Synchronised**) that may arise, as time progresses without external supplies being restored.

- (b) **Block Loading Capability.** This should be provided in either graphical or tabular format showing the estimated block loading capability from 0MW to **Registered Capacity**. Any particular 'hold' points should also be identified. The data of each **BM Unit** should be provided for the condition of a 'hot' unit that was **Synchronised** just prior to the **Total Shutdown** or **Partial Shutdown** and also for the condition of a 'cold' unit. The block loading assessment should be done against a frequency variation of 49.5Hz – 50.5Hz.

PC.A.6 **USERS' SYSTEM DATA**

PC.A.6.1 **Introduction**

PC.A.6.1.1 Each **User**, whether connected directly via an existing **Connection Point** to the **GB Transmission System** or seeking such a direct connection, shall provide **NGET** with data on its **User System** which relates to the **Connection Site** containing the **Connection Point** both current and forecast, as specified in PC.A.6.2 to PC.A.6.6.

PC.A.6.1.2 Each **User** must reflect the system effect at the **Connection Site(s)** of any third party **Embedded** within its **User System** whether existing or proposed.

PC.A.6.1.3 PC.A.6.2, and PC.A.6.4 to PC.A.6.6 consist of data which is only to be supplied to **NGET** at **NGET's** reasonable request. In the event that **NGET** identifies a reason for requiring this data, **NGET** shall write to the relevant **User(s)**, requesting the data, and explaining the reasons for the request. If the **User(s)** wishes, **NGET** shall also arrange a meeting at which the request for data can be discussed, with the objective of identifying the best way in which **NGET's** requirements can be met.

PC.A.6.2 **Transient Overvoltage Assessment Data**

PC.A.6.2.1 It is occasionally necessary for **NGET** to undertake transient overvoltage assessments (e.g. capacitor switching transients, switchgear transient recovery voltages, etc). At **NGET's** reasonable request, each **User** is required to provide the following data with respect to the **Connection Site**, current and forecast, together with a **Single Line Diagram** where not already supplied under PC.A.2.2.1, as follows:-

- (a) busbar layout plan(s), including dimensions and geometry showing positioning of any current and voltage transformers, through bushings, support insulators, disconnectors, circuit breakers, surge arresters, etc. Electrical parameters of any associated current and voltage transformers, stray capacitances of wall bushings and support insulators, and grading capacitances of circuit breakers;
- (b) Electrical parameters and physical construction details of lines and cables connected at that busbar. Electrical parameters of all plant e.g., transformers (including neutral earthing impedance or zig-zag transformers, if any), series reactors and shunt compensation equipment connected at that busbar (or to the tertiary of a transformer) or by lines or cables to that busbar;
- (c) Basic insulation levels (BIL) of all **Apparatus** connected directly, by lines or by cables to the busbar;

- (d) characteristics of overvoltage **Protection** devices at the busbar and at the termination points of all lines, and all cables connected to the busbar;
- (e) fault levels at the lower voltage terminals of each transformer connected directly or indirectly to the **GB Transmission System** without intermediate transformation;
- (f) the following data is required on all transformers operating at **Supergrid Voltage** throughout **Great Britain** and, in Scotland, also at 132kV: three or five limb cores or single phase units to be specified, and operating peak flux density at nominal voltage;
- (g) an indication of which items of equipment may be out of service simultaneously during **Planned Outage** conditions.

PC.A.6.3

User's Protection Data

PC.A.6.3.1

Protection

The following information is required which relates only to **Protection** equipment which can trip or inter-trip or close any **Connection Point** circuit-breaker or any **Transmission** circuit-breaker. This information need only be supplied once, in accordance with the timing requirements set out in PC.A.1.4(b), and need not be supplied on a routine annual basis thereafter, although **NGET** should be notified if any of the information changes

- (a) a full description, including estimated settings, for all relays and **Protection** systems installed or to be installed on the **User's System**;
- (b) a full description of any auto-reclose facilities installed or to be installed on the **User's System**, including type and time delays;
- (c) a full description, including estimated settings, for all relays and **Protection** systems or to be installed on the generator, generator transformer, **Station Transformer** and their associated connections;
- (d) for **Generating Units** (other than **Power Park Units**) or **Power Park Modules** or **DC Converters** at a **DC Converter Station** having (or intended to have) a circuit breaker at the generator terminal voltage, clearance times for electrical faults within the **Generating Unit** (other than a **Power Park Unit**) or **Power Park Module** zone;
- (e) the most probable fault clearance time for electrical faults on any part of the **User's System** directly connected to the **GB Transmission System**.

PC.A.6.4

Harmonic Studies

PC.A.6.4.1 It is occasionally necessary for **NGET** to evaluate the production/magnification of harmonic distortion on **NGET** and **User's Systems**, especially when **NGET** is connecting equipment such as capacitor banks. At **NGET's** reasonable request, each **User** is required to submit data with respect to the **Connection Site**, current and forecast, and where not already supplied under PC.A.2.2.4 and PC.A.2.2.5, as follows:-

PC.A.6.4.2 Overhead lines and underground cable circuits of the **User's Subtransmission System** must be differentiated and the following data provided separately for each type:-

Positive phase sequence resistance;
Positive phase sequence reactance;
Positive phase sequence susceptance;

and for all transformers connecting the **User's Subtransmission System** to a lower voltage:-

Rated MVA;
Voltage Ratio;
Positive phase sequence resistance;
Positive phase sequence reactance;

and at the lower voltage points of those connecting transformers:-

Equivalent positive phase sequence susceptance;
Connection voltage and Mvar rating of any capacitor bank and component design parameters if configured as a filter;
Equivalent positive phase sequence interconnection impedance with other lower voltage points;
The minimum and maximum **Demand** (both MW and Mvar) that could occur;
Harmonic current injection sources in Amps at the Connection voltage points. Where the harmonic injection current comes from a diverse group of sources, the equivalent contribution may be established from appropriate measurements;
Details of traction loads, eg connection phase pairs, continuous variation with time, etc;
An indication of which items of equipment may be out of service simultaneously during **Planned Outage** conditions.

PC.A.6.5 Voltage Assessment Studies

It is occasionally necessary for **NGET** to undertake detailed voltage assessment studies (e.g., to examine potential voltage instability, voltage control co-ordination or to calculate voltage step changes). At **NGET's** reasonable request, each **User** is required to submit the following data where not already supplied under PC.A.2.2.4 and PC.A.2.2.5:-

For all circuits of the **User's Subtransmission System**:-

Positive Phase Sequence Reactance;

Positive Phase Sequence Resistance;
Positive Phase Sequence Susceptance;
Mvar rating of any reactive compensation equipment;

and for all transformers connecting the **User's Subtransmission System** to a lower voltage:-

Rated MVA;
Voltage Ratio;
Positive phase sequence resistance;
Positive Phase sequence reactance;
Tap-changer range;
Number of tap steps;
Tap-changer type: on-load or off-circuit;
AVC/tap-changer time delay to first tap movement;
AVC/tap-changer inter-tap time delay;

and at the lower voltage points of those connecting transformers:-

Equivalent positive phase sequence susceptance;
Mvar rating of any reactive compensation equipment;
Equivalent positive phase sequence interconnection impedance with other lower voltage points;
The maximum **Demand** (both MW and Mvar) that could occur;
Estimate of voltage insensitive (constant power) load content in % of total load at both winter peak and 75% off-peak load conditions.

PC.A.6.6 Short Circuit Analysis:

PC.A.6.6.1 Where prospective short-circuit currents on equipment owned, operated or managed by **NGET** are greater than 90% of the equipment rating, and in **NGET**'s reasonable opinion more accurate calculations of short-circuit currents are required, then at **NGET**'s request each **User** is required to submit data with respect to the **Connection Site**, current and forecast, and where not already supplied under PC.A.2.2.4 and PC.A.2.2.5, as follows:

PC.A.6.6.2 For all circuits of the **User's Subtransmission System**:-

Positive phase sequence resistance;
Positive phase sequence reactance;
Positive phase sequence susceptance;
Zero phase sequence resistance (both self and mutuals);
Zero phase sequence reactance (both self and mutuals);
Zero phase sequence susceptance (both self and mutuals);

and for all transformers connecting the **User's Subtransmission System** to a lower voltage:-

Rated MVA;
Voltage Ratio;
Positive phase sequence resistance (at max, min and nominal tap);

Positive Phase sequence reactance (at max, min and nominal tap);
Zero phase sequence reactance (at nominal tap);
Tap changer range;
Earthing method: direct, resistance or reactance;
Impedance if not directly earthed;

and at the lower voltage points of those connecting transformers:-

The maximum **Demand** (in MW and Mvar) that could occur;
Short-circuit infeed data in accordance with PC.A.2.5.6 unless the **User's** lower voltage network runs in parallel with the **User's Subtransmission System**, when to prevent double counting in each node infeed data, a π equivalent comprising the data items of PC.A.2.5.6 for each node together with the positive phase sequence interconnection impedance between the nodes shall be submitted.

PC.A.7

ADDITIONAL DATA FOR NEW TYPES OF POWER STATIONS, DC CONVERTER STATIONS AND CONFIGURATIONS

Notwithstanding the **Standard Planning Data** and **Detailed Planning Data** set out in this Appendix, as new types of configurations and operating arrangements of **Power Stations** and **DC Converter Stations** emerge in future, **NGET** may reasonably require additional data to represent correctly the performance of such **Plant** and **Apparatus** on the **System**, where the present data submissions would prove insufficient for the purpose of producing meaningful **System** studies for the relevant parties.

PART 3

NETWORK DATA

PC.A.8 To allow a **User** to model the **GB Transmission System**, **NGET** will provide, upon request, the following **Network Data** to **Users**, calculated in accordance with **Good Industry Practice**:-

PC.A.8.1 Single Point of Connection

For a **Single Point of Connection** to a **User's System**, as an equivalent 400kV or 275kV source and also in Scotland as an equivalent 132kV source, the data (as at the HV side of the **Point of Connection** reflecting data given to **NGET** by **Users**) will be given to a **User** as follows:-

The data items listed under the following parts of PC.A.8.3:-

(a) (i), (ii), (iii), (iv), (v) and (vi)

and the data items shall be provided in accordance with the detailed provisions of PC.A.8.3 (b) - (e).

PC.A.8.2 Multiple Point of Connection

For a **Multiple Point of Connection** to a **User's System** equivalents suitable for use in loadflow and fault level analysis shall be provided. These equivalents will normally be in the form of a π model or extension with a source (or demand for a loadflow equivalent) at each node and a linking impedance. The boundary nodes for the equivalent shall be either at the **Connection Point** or (where **NGET** agrees) at suitable nodes (the nodes to be agreed with the **User**) within the **GB Transmission System**. The data at the **Connection Point** will be given to a **User** as follows:-

The data items listed under the following parts of PC.A.8.3:-

(a) (i), (ii), (iv), (v), (vi), (vii), (viii), (ix), (x) and (xi)

and the data items shall be provided in accordance with the detailed provisions of PC.A.8.3 (b) - (e).

When an equivalent of this form is not required **NGET** will not provide the data items listed under the following parts of PC.A.8.3:-

(a) (vii), (viii), (ix), (x) and (xi)

PC.A.8.3 Data Items

(a) The following is a list of data utilised in this part of the **PC**. It also contains rules on the data which generally apply.

(i) symmetrical three-phase short circuit current infeed at the instant of fault from the **GB Transmission System**, (I_1 ");

- (ii) symmetrical three-phase short circuit current from the **GB Transmission System** after the subtransient fault current contribution has substantially decayed, (I_1');
 - (iii) the zero sequence source resistance and reactance values at the **Point of Connection**, consistent with the maximum infeed below;
 - (iv) the pre-fault voltage magnitude at which the maximum fault currents were calculated;
 - (v) the positive sequence X/R ratio at the instant of fault;
 - (vi) the negative sequence resistance and reactance values of the **GB Transmission System** seen from the **Point of Connection**, if substantially different from the values of positive sequence resistance and reactance which would be derived from the data provided above;
 - (vii) the initial positive sequence resistance and reactance values of the two (or more) sources and the linking impedance(s) derived from a fault study constituting the (π) equivalent and evaluated without the **User** network and load and where appropriate without elements of the **GB Transmission System** between the **User** network and agreed boundary nodes;
 - (viii) the positive sequence resistance and reactance values of the two (or more) sources and the linking impedance(s) derived from a fault study, considering the short circuit current contributions after the subtransient fault current contribution has substantially decayed, constituting the (π) equivalent and evaluated without the **User** network and load, and where appropriate without elements of the **GB Transmission System** between the **User** network and agreed boundary nodes;
 - (ix) the corresponding zero sequence impedance values of the (π) equivalent produced for use in fault level analysis;
 - (x) the **Demand** and voltage at the boundary nodes and the positive sequence resistance and reactance values of the linking impedance(s) derived from a loadflow study considering **GB Transmission System** peak **Demand** constituting the (π) loadflow equivalent; and,
 - (xi) where the agreed boundary nodes are not at a **Connection Point**, the positive sequence and zero sequence impedances of all elements of the **GB Transmission System** between the **User** network and agreed boundary nodes that are not included in the equivalent.
- (b) To enable the model to be constructed, **NGET** will provide data based on the following conditions.

- (c) The initial symmetrical three phase short circuit current and the transient period three phase short circuit current will normally be derived from the fixed impedance studies. The latter value should be taken as applying at times of 120ms and longer. Shorter values may be interpolated using a value for the subtransient time constant of 40ms. These fault currents will be obtained from a full **System** study based on load flow analysis that takes into account any existing flow across the point of connection being considered.
- (d) Since the equivalent will be produced for the 400kV or 275kV and also in Scotland 132kV parts of the **GB Transmission System NGET** will provide the appropriate supergrid transformer data.
- (e) The positive sequence X/R ratio and the zero sequence impedance value will correspond to the **NGET** source network only, that is with the section of network if any with which the equivalent is to be used excluded. These impedance values will be derived from the condition when all **Generating Units** are **Synchronised** to the **GB Transmission System** or a **User's System** and will take account of active sources only including any contribution from the load to the fault current. The passive component of the load itself or other system shunt impedances should not be included.
- (f) A **User** may at any time, in writing, specifically request for an equivalent to be prepared for an alternative **System** condition, for example where the **User's System** peak does not correspond to the **GB Transmission System** peak, and **NGET** will, insofar as such request is reasonable, provide the information as soon as reasonably practicable following the request.

PLANNING CODE APPENDIX B

Single Line Diagram

The diagrams below show three examples of single line diagrams, showing the detail that should be incorporated in the diagram. The first example is for an **Network Operator** connection, the second for a **Generator** connection, the third for a **Power Park Module** electrically equivalent system.

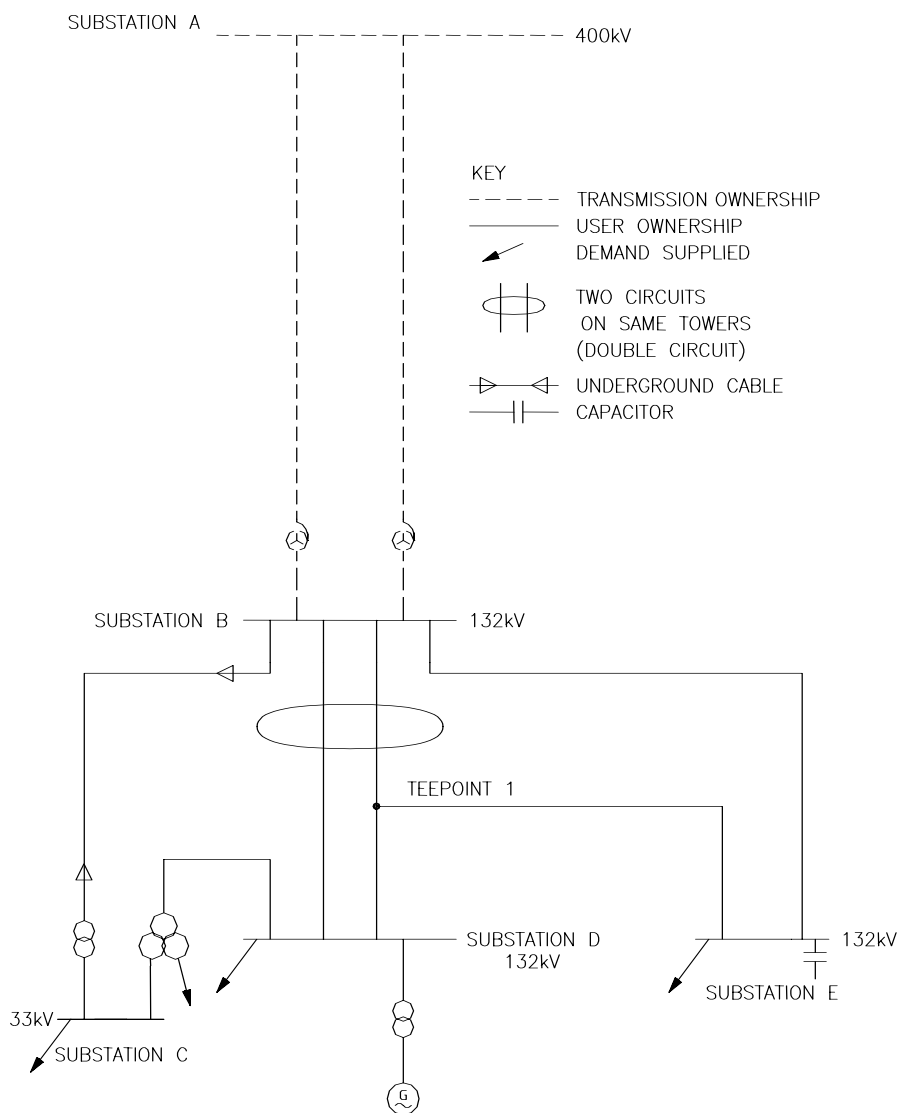

UNCONTROLLED COPY
NOT SUBJECT TO
REVISION SYSTEM

41/18826_1_1

ISS D
29-07-04

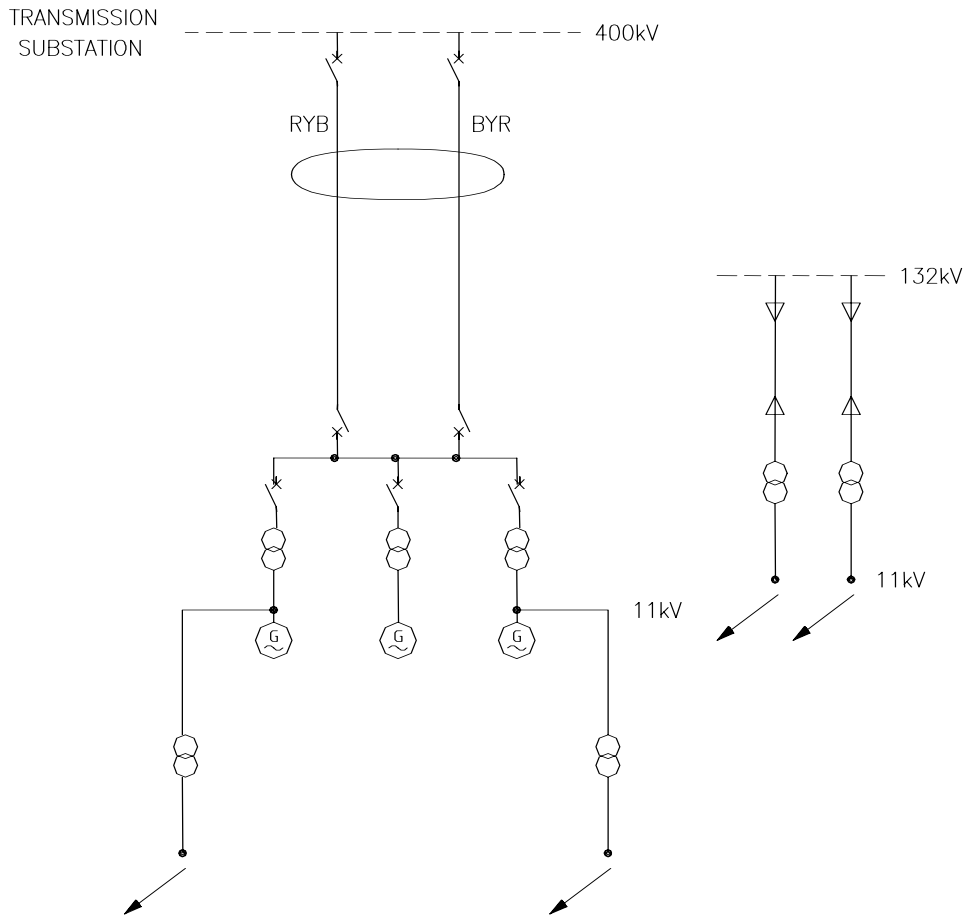

- KEY
- TRANSMISSION OWNERSHIP
 - USER OWNERSHIP
 - ↙ DEMAND SUPPLIED
 - ⊖ TWO CIRCUITS ON SAME TOWERS (DOUBLE CIRCUIT)
 - ⚡ UNDERGROUND CABLE

UNCONTROLLED COPY
NOT SUBJECT TO
REVISION SERVICES C

41/19468_1_1 ISS D
29-07-04

Power Park Module Single Line Diagram

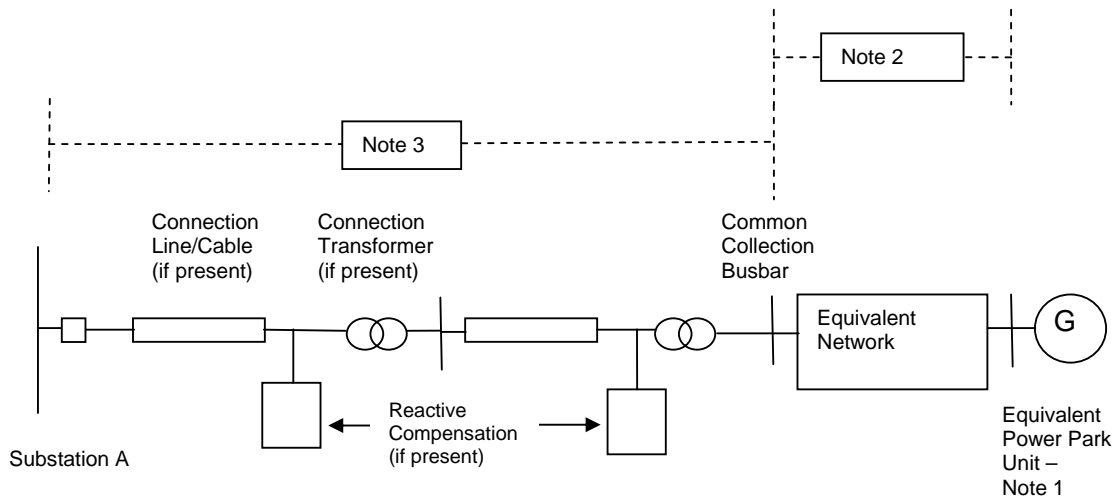

Notes:

- 1) The electrically equivalent **Power Park Unit** consists of a number of actual **Power Park Units** of the same type ie. any equipment external to the **Power Park Unit** terminals is considered as part of the Equivalent Network. **Power Park Units** of different types shall be included in separate electrically equivalent **Power Park Units**. The total number of equivalent **Power Park Units** shall represent all of the actual **Power Park Units** in the **Power Park Module**.
- 2) Separate electrically equivalent networks are required for each different type of electrically equivalent **Power Park Unit**. The electrically equivalent network shall include all equipment between the **Power Park Unit** terminals and the **Common Collection Busbar**.
- 3) All **Plant** and **Apparatus** including the circuit breakers, transformers, lines, cables and reactive compensation plant between the **Common Collection Busbar** and Substation A shall be shown.

PLANNING CODE APPENDIX C

- C1.1 Planning and design of the **SPT** and **SHETL Transmission Systems** is based generally, but not totally, on criteria which evolved from joint consultation among various **Transmission Licensees** responsible for design of the **GB Transmission System**.
- C1.2 The above criteria are set down within the standards, memoranda, recommendations and reports and are provided as a guide to system planning. It should be noted that each scheme for reinforcement or modification of the **Transmission System** is individually designed in the light of economic and technical factors associated with the particular system limitations under consideration.
- C1.3 The tables below identify the literature referred to above, together with the main topics considered within each document.

PART 1 – SHETL's TECHNICAL AND DESIGN CRITERIA

ITEM No.	DOCUMENT	REFERENCE No.
1	GB Security and Quality of Supply Standard	Version 1
2	System Phasing	TPS 13/4
3	not used	
4	Planning Limits for Voltage Fluctuations Caused by Industrial, Commercial and Domestic Equipment in the United Kingdom	ER P28
5	EHV or HV Supplies to Induction Furnaces Voltage unbalance limits. Harmonic current limits.	ER P16 (Supported by ACE Report No.48)
6	Planning Levels for Harmonic Voltage Distortion and the Connection of Non-Linear Loads to Transmission Systems and Public Electricity Supply Systems in the United Kingdom Harmonic distortion (waveform). Harmonic voltage distortion. Harmonic current distortion. Stage 1 limits. Stage 2 limits. Stage 3 Limits Addition of Harmonics Short Duration Harmonics Site Measurements	ER G5/4 (Supported by ACE Report No.73)

ITEM No.	DOCUMENT	REFERENCE No.
7	<p>AC Traction Supplies to British Rail</p> <p>Type of supply point to railway system.</p> <p>Estimation of traction loads.</p> <p>Nature of traction current.</p> <p>System disturbance estimation.</p> <p>Earthing arrangements.</p>	ER P24
8	<p>Operational Memoranda</p> <p>Main System operating procedure.</p> <p>Operational standards of security.</p> <p>Voltage and reactive control on main system.</p> <p>System warnings and procedures for instructed load reduction.</p> <p>Continuous tape recording of system control telephone messages and instructions.</p> <p>Emergency action in the event of an exceptionally serious breakdown of the main system.</p>	<p>(SOM)</p> <p>SOM 1</p> <p>SOM 3</p> <p>SOM 4</p> <p>SOM 7</p> <p>SOM 10</p> <p>SOM 15</p>
9	Planning Limits for Voltage Unbalance in the United Kingdom.	ER P29

PART 2 – SPT's TECHNICAL AND DESIGN CRITERIA

ITEM No.	DOCUMENT	Reference No.
1	GB Security and Quality of Supply Standard	Version 1
2	System Phasing	TDM 13/10,002 Issue 4
3	not used	
4	Planning Limits for Voltage Fluctuations Caused by Industrial, Commercial and Domestic Equipment in the United Kingdom	ER P28
5	EHV or HV Supplies to Induction Furnaces Voltage Unbalance limits. Harmonic current limits.	ER P16 (Supported by ACE Report No.48)
6	Planning Levels for Harmonic Voltage Distortion and the Connection of Non-Linear Loads to Transmission Systems and Public Electricity Supply Systems in the United Kingdom Harmonic distortion (waveform). Harmonic voltage distortion. Harmonic current distortion. Stage 1 limits. Stage 2 limits. Stage 3 Limits Addition of Harmonics Short Duration Harmonics Site Measurements	ER G5/4 Supported by ACE Report No.73)
7	AC Traction Supplies to British Rail Type of supply point to railway system. Estimation of traction loads. Nature of traction current. System disturbance estimation. Earthing arrangements.	ER P24

APPENDIX D

Pursuant to PC.3.4, **NGET** will not disclose to a **Relevant Transmission Licensee** data items specified in the below extract:

PC REFERENCE	DATA DESCRIPTION	UNITS	DATA CAT.
PC.A.3.2.2 (f) (i)	Performance Chart at Generating Unit stator terminals		SPD
PC.A.3.2.2 (b)	Output Usable (on a monthly basis)	MW	SPD
PC.A.5.3.2 (d) Option 1 (iii)	GOVERNOR AND ASSOCIATED PRIME MOVER PARAMETERS Option 1 BOILER & STEAM TURBINE DATA Boiler time constant (Stored Active Energy) HP turbine response ratio: (Proportion of Primary Response arising from HP turbine) HP turbine response ratio: (Proportion of High Frequency Response arising from HP turbine)	S % %	DPD DPD DPD
Part of PC.A.5.3.2 (d) Option 2 (i)	Option 2 All Generating Units Governor Deadband - Maximum Setting - Normal Setting - Minimum Setting	 ±Hz ±Hz ±Hz	 DPD DPD DPD
Part of PC.A.5.3.2 (d) Option 2 (ii)	Steam Units Reheater Time Constant Boiler Time Constant HP Power Fraction IP Power Fraction	 sec sec % %	 DPD DPD DPD DPD

Part of PC.A.5.3.2 (d) Option 2 (iii)	Gas Turbine Units Waste Heat Recovery Boiler Time Constant		
Part of PC.A.5.3.2 (e)	UNIT CONTROL OPTIONS* Maximum droop Minimum droop Maximum frequency deadband Normal frequency deadband Minimum frequency deadband Maximum Output deadband Normal Output deadband Minimum Output deadband Frequency settings between which Unit Load Controller droop applies: Maximum Normal Minimum Sustained response normally selected	 % % ±Hz ±Hz ±Hz ±MW ±MW ±MW Hz Hz Hz Yes/No	 DPD DPD DPD DPD DPD DPD DPD DPD DPD
PC.A.3.2.2 (f) (ii)	Performance Chart of a Power Park Modules at the connection point		SPD
PC.A.3.2.2 (b)	Output Usable (on a monthly basis)	MW	SPD
PC.A.3.2.2 (e) and (j)	DC CONVERTER STATION DATA ACTIVE POWER TRANSFER CAPABILITY (PC.A.3.2.2) Import MW available in excess of Registered Import Capacity . Time duration for which MW in excess of Registered Import Capacity is available Export MW available in excess of Registered Capacity . Time duration for which MW in excess of Registered Capacity is available	 MW Min MW Min	 SPD SPD SPD SPD

Part of PC.A.5.4.3.3	LOADING PARAMETERS		
	MW Export		
	Nominal loading rate	MW/s	DPD
	Maximum (emergency) loading rate	MW/s	DPD
	MW Import		
	Nominal loading rate	MW/s	DPD
	Maximum (emergency) loading rate	MW/s	DPD

< End of **Planning Code (PC)** >

CONNECTION CONDITIONS

CONTENTS

(This contents page does not form part of the Grid Code)

<u>Paragraph No/Title</u>	<u>Page Number</u>
CC.1 INTRODUCTION.....	1
CC.2 OBJECTIVE	1
CC.3 SCOPE.....	1
CC.4 PROCEDURE	2
CC.5 CONNECTION.....	2
CC.6 TECHNICAL, DESIGN AND OPERATIONAL CRITERIA	
CC.6.1 GB Transmission System Performance Characteristics	5
CC.6.2 Plant and Apparatus relating to Connection Site	
CC.6.2.1 General Requirements.....	7
CC.6.2.2 Requirements at Connection Points that relate to Generators or DC Converter Station owners	9
CC.6.2.3 Requirements. at Connection Points relating to Network Operator and Non-Embedded Customers	11
CC.6.3 General Generating Unit Requirements	14
CC.6.4 General Network Operator and Non-Embedded Customer Requirements	26
CC.6.5 Communications Plant	27
CC.6.6 System Monitoring.....	31
CC.7 SITE RELATED CONDITIONS	
CC.7.2 Responsibilities for Safety	31
CC.7.3 Site Responsibility Schedules	33
CC.7.4 Operation and Gas Zone Diagrams	33
CC.7.5 Site Common Drawings.....	35
CC.7.6 Access.....	37
CC.7.7 Maintenance Standards	37
CC.7.8 Site Operational Procedures	37
CC.8 ANCILLARY SERVICES	
CC.8.1 System Ancillary Services	38
CC.8.2 Commercial Ancillary Services.....	38
APPENDIX 1 – SITE RESPONSIBILITY SCHEDULES	40
APPENDIX 2 - OPERATION DIAGRAMS	48

APPENDIX 3 - MINIMUM FREQUENCY RESPONSE REQUIREMENTS54

APPENDIX 4 – FAULT RIDE THROUGH REQUIREMENT59

APPENDIX 5 - LOW FREQUENCY RELAYS62

**APPENDIX 6 - PERFORMANCE REQUIREMENTS FOR SYNCHRONOUS
GENERATING UNITS.....65**

**APPENDIX 7 - PERFORMANCE REQUIREMENTS FOR NON-SYNCHRONOUS
GENERATING UNITS, DC CONVERTERS AND POWER PARK MODULES70 |**

APPENDIX 6

PERFORMANCE REQUIREMENTS FOR CONTINUOUSLY ACTING AUTOMATIC EXCITATION CONTROL SYSTEMS FOR SYNCHRONOUS GENERATING UNITS

CC.A.6.1 SCOPE

CC.A.6.1.1 This Appendix sets out the performance requirements of continuously acting automatic excitation control systems for **Synchronous Generating Units** that must be complied with by the **User**. This Appendix does not limit any site specific requirements that may be included in a **Bilateral Agreement** where in **NGET's** reasonable opinion these facilities are necessary for system reasons.

CC.A.6.1.2 Where the requirements may vary the likely range of variation is given in this Appendix. It may be necessary to specify values outside this range where **NGET** identifies a system need, and notwithstanding anything to the contrary **NGET** may specify in the **Bilateral Agreement** values outside of the ranges provided in this Appendix 6. The most common variations are in the on-load excitation ceiling voltage requirements and the response time required of the **Exciter**. Actual values will be included in the **Bilateral Agreement**.

CC.A.6.1.3 Should a **Generator** anticipate making a change to the excitation control system it shall notify **NGET** under the **Planning Code** (PC.A.1.2(b) and (c)) as soon as the **Generator** anticipates making the change. The change may require a revision to the **Bilateral Agreement**.

CC.A.6.2 Requirements

CC.A.6.2.1 The **Excitation System** of a **Synchronous Generating Unit** shall include an excitation source (**Exciter**), a **Power System Stabiliser** and a continuously acting **Automatic Voltage Regulator (AVR)** and shall meet the following functional specification.

CC.A.6.2.2 In respect of **Synchronous Generating Units** with a **Completion Date** on or after 1 January 2009, and **Synchronous Generating Units** with a **Completion Date** before 1 January 2009 subject to a **Modification** to the excitation control facilities where the **Bilateral Agreement** does not specify otherwise, the continuously acting automatic excitation control system shall include a **Power System Stabiliser (PSS)** as a means of supplementary control. The functional specification of the **Power System Stabiliser** is included in CC.A.6.2.5.

CC.A.6.2.3 Steady State Voltage Control

CC.A.6.2.3.1 An accurate steady state control of the **Generating Unit** pre-set terminal voltage is required. As a measure of the accuracy of the steady-state voltage control, the **Automatic Voltage Regulator** shall have static zero frequency gain, sufficient to limit the change in terminal voltage to a drop not exceeding 0.5% of rated terminal voltage, when the **Generating Unit** output is gradually changed from zero to rated MVA output at rated voltage, **Active Power** and **Frequency**.

CC.A.6.2.4 Transient Voltage Control

CC.A.6.2.4.1 For a step change from 90% to 100% of the nominal **Generating Unit** terminal voltage, with the **Generating Unit** on open circuit, the **Excitation System** response shall have a damped oscillatory characteristic. For this characteristic, the time for the **Generating Unit** terminal voltage to first reach 100% shall be less than 0.6 seconds. Also, the time to settle within 5% of the voltage change shall be less than 3 seconds.

CC.A.6.2.4.2 To ensure that adequate synchronising power is maintained, when the **Generating Unit** is subjected to a large voltage disturbance, the **Exciter** whose output is varied by the **Automatic Voltage Regulator** shall be capable of providing its achievable upper and lower limit ceiling voltages to the **Generating Unit** field in a time not exceeding that specified in the **Bilateral Agreement**. This will normally be not less than 50 ms and not greater than 300 ms. The achievable upper and lower limit ceiling voltages may be dependent on the voltage disturbance.

CC.A.6.2.4.3 The **Exciter** shall be capable of attaining an **Excitation System On Load Positive Ceiling Voltage** of not less than a value specified in the **Bilateral Agreement** that will be

not less than 2 per unit (pu)
normally not greater than 3 pu
exceptionally up to 4 pu

of **Rated Field Voltage** when responding to a sudden drop in voltage of 10 percent or more at the **Generating Unit** terminals. **NGET** may specify a value outside the above limits where **NGET** identifies a system need.

CC.A.6.2.4.4 If a static type **Exciter** is employed:

- (i) the field voltage should be capable of attaining a negative ceiling level specified in the **Bilateral Agreement** after the removal of the step disturbance of CC.A.6.2.4.3. The specified value will be 80% of the value specified in CC.A.6.2.4.3. **NGET** may specify a value outside the above limits where **NGET** identifies a system need.
- (ii) the **Exciter** must be capable of maintaining free firing when the **Generating Unit** terminal voltage is depressed to a level which may be between 20% to 30% of rated terminal voltage
- (iii) the **Exciter** shall be capable of attaining a positive ceiling voltage not less than 80% of the **Excitation System On Load Positive Ceiling Voltage** upon recovery of the **Generating Unit** terminal voltage to 80% of rated terminal voltage following fault clearance. **NGET** may specify a value outside the above limits where **NGET** identifies a system need.
- (iv) The requirement to provide a separate power source for the **Exciter** will be specified in the **Bilateral Agreement** if **NGET** identifies a **Transmission System** need.

CC.A.6.2.5 Power Oscillations Damping Control

CC.A.6.2.5.1 To allow the **Generating Unit** to maintain second and subsequent swing stability and also to ensure an adequate level of low frequency electrical damping power, the **Automatic Voltage Regulator** shall include a **Power System Stabiliser** as a means of supplementary control.

CC.A.6.2.5.2 Whatever supplementary control signal is employed, it shall be of the type which operates into the **Automatic Voltage Regulator** to cause the field voltage to act in a manner which results in the damping power being improved while maintaining adequate synchronising power.

CC.A.6.2.5.3 The arrangements for the supplementary control signal shall ensure that the **Power System Stabiliser** output signal relates only to changes in the supplementary control signal and not the steady state level of the signal. For example, if generator electrical power output is chosen as a supplementary control signal then the **Power System Stabiliser** output should relate only to changes in generator electrical power output and not the steady state level of power output. Additionally the **Power System**

Stabiliser should not react to mechanical power changes in isolation for example during rapid changes in steady state load or when providing frequency response.

- CC.A.6.2.5.4 The output signal from the **Power System Stabiliser** shall be limited to not more than $\pm 10\%$ of the **Generating Unit** terminal voltage signal at the **Automatic Voltage Regulator** input. The gain of the **Power System Stabiliser** shall be such that an increase in the gain by a factor of 3 shall not cause instability.
- CC.A.6.2.5.5 The **Power System Stabiliser** shall include elements that limit the bandwidth of the output signal. The bandwidth limiting must ensure that the highest frequency of response cannot excite torsional oscillations on other plant connected to the network. A bandwidth of 0-5Hz would be judged to be acceptable for this application.
- CC.A.6.2.5.6 The **Generator** will agree **Power System Stabiliser** settings with **NGET** prior to the on-load commissioning detailed in BC2.11.2(d). To allow assessment of the performance before on-load commissioning the **Generator** will provide to **NGET** a report containing:
- i. the **Excitation System** model including the **Power System Stabiliser** with settings as required under the **Planning Code** (PC.A.5.3.2(c)).
 - ii. on load time series simulations of the response of the **Excitation System** with and without the **Power System Stabiliser** to 2% and 10% steps in the reference voltage and a three phase short circuit fault applied to the higher voltage side of the **Generating Unit** transformer for 100 ms. The results should show field voltage, **Generating Unit** terminal voltage, **Power System Stabiliser** output and **Generating Unit Active Power** and **Reactive Power** output.
 - iii. gain and phase Bode diagrams for the open loop frequency domain response of the **Generating Unit Excitation System** with and without the **Power System Stabiliser**. These should be in a format to allow assessment of the phase contribution of the **Power System Stabiliser** and the gain and phase margin of the **Excitation System** with the **Power System Stabiliser**.
- CC.A.6.2.5.7 The **Power System Stabiliser** must be active within the **Excitation System** at all times when **Synchronised** including when the **Under Excitation Limiter** or **Over-Excitation Limiter** are active. When operating at low load when **Synchronising** or **De-Synchronising** a **Generating Unit**, the **Power System Stabiliser** may be out of service.
- CC.A.6.2.5.8 Where a **Power System Stabiliser** is fitted to a **Pumped Storage Unit** it must function when the **Pumped Storage Unit** is in both generating and pumping modes.
- CC.A.6.2.6 Overall **Excitation System** Control Characteristics
- CC.A.6.2.6.1 The overall **Excitation System** shall include elements that limit the bandwidth of the output signal. The bandwidth limiting must be consistent with the speed of response requirements and ensure that the highest frequency of response cannot excite torsional oscillations on other plant connected to the network. A bandwidth of 0-5 Hz will be judged to be acceptable for this application.
- CC.A.6.2.6.2 The response of the **Automatic Voltage Regulator** combined with the **Power System Stabiliser** shall be demonstrated by injecting similar step signal disturbances into the **Automatic Voltage Regulator** reference with the **Generating Unit** operating at points specified by **NGET** (up to rated MVA output). The damping shall be judged to be adequate if the corresponding **Active Power** response to the disturbances decays within two cycles of oscillation.

CC.A.6.2.6.3 The frequency domain tuning of the **Power System Stabiliser** shall also be demonstrated by injecting a 0.2Hz-3Hz band limited random noise signal into the **Automatic Voltage Regulator** reference with the **Generating Unit** operating at points specified by **NGET** (up to rated MVA output). The tuning of the **Power System Stabiliser** shall be judged to be adequate if the corresponding **Active Power** response shows improved damping with the **Power System Stabiliser** in combination with the **Automatic Voltage Regulator** compared with the **Automatic Voltage Regulator** alone over the frequency range 0.3Hz – 2Hz.

CC.A.6.2.7 Under-Excitation Limiters

CC.A.6.2.7.1 The security of the power system shall also be safeguarded by means of MVAR **Under Excitation Limiters** fitted to the generator **Excitation System**. The **Under Excitation Limiter** shall prevent the **Automatic Voltage Regulator** reducing the generator excitation to a level which would endanger synchronous stability. The **Under Excitation Limiter** shall operate when the excitation system is providing automatic control. The **Under Excitation Limiter** shall respond to changes in the **Active Power** (MW) and the **Reactive Power** (MVA), and to the square of the generator voltage in such a direction that an increase in voltage will permit an increase in leading MVA. The characteristic of the **Under Excitation Limiter** shall be substantially linear from no-load to rated load at any setting and shall be readily adjustable.

CC.A.6.2.7.2 The performance of the **Under Excitation Limiter** shall be independent of the rate of change of the **Generating Unit** load and shall be demonstrated by testing its response to a step change corresponding to a 2% decrease in **Automatic Voltage Regulator** reference voltage when the generator is operating just off the limit line, as set up. The resulting maximum overshoot shall not exceed 4% of the **Generating Unit** rated MVA. The operating point of the **Generating Unit** shall be returned to a steady state value at the limit line and the final settling time shall not be greater than 5 seconds. When the step change in **Automatic Voltage Regulator** reference voltage is reversed, the field voltage should begin to respond without any delay and should not be held down by the **Under Excitation Limiter**. Operation into or out of the preset limit levels shall ensure that any resultant oscillations are damped so that the disturbance is within 0.5% of the **Generating Unit** MVA rating within a period of 5 seconds.

CC.A.6.2.7.3 The **Generator** shall also make provision to prevent the reduction of the **Generating Unit** excitation to a level which would endanger synchronous stability when the **Excitation System** is under manual control.

CC.A.6.2.8 Over-Excitation Limiters

CC.A.6.2.8.1 The settings of the **Over-Excitation Limiter**, where it exists, shall ensure that the generator excitation is not limited to less than the maximum value that can be achieved whilst ensuring the **Generating Unit** is operating within its design limits. If the generator excitation is reduced following a period of operation at a high level, the rate of reduction shall not exceed that required to remain within any time dependent operating characteristics of the **Generating Unit**.

CC.A.6.2.8.2 The performance of the **Over-Excitation Limiter**, where it exists, shall be demonstrated by testing its response to a step increase in the **Automatic Voltage Regulator** reference voltage that results in operation of the **Over Excitation Limiter**. Prior to application of the step the **Generating Unit** shall be generating **Rated Active Power** and operating within its continuous **Reactive Power** capability. The size of the

step will be determined by the minimum value necessary to operate the **Over-Excitation Limiter** and will be agreed by **NET** and the **Generator**. The resulting operation beyond the **Over-Excitation Limit** shall be controlled by the **Over-Excitation Limiter** without the operation of any protection that could trip the **Generating Unit**. The step shall be removed immediately on completion of the test.

- CC.A.6.2.8.3 The **Generator** shall also make provision to prevent any over-excitation restriction of the generator when the **Excitation System** is under manual control, other than that necessary to ensure the **Generating Unit** is operating within its design limits.

APPENDIX 7

PERFORMANCE REQUIREMENTS FOR CONTINUOUSLY ACTING AUTOMATIC VOLTAGE CONTROL SYSTEMS FOR **NON-SYNCHRONOUS GENERATING UNITS, DC CONVERTERS AND POWER PARK MODULES**

CC.A.7.1 SCOPE

CC.A.7.1.1 This Appendix sets out the performance requirements of continuously acting automatic voltage control systems for **Non-Synchronous Generating Units, DC Converters** and **Power Park Modules** that must be complied with by the **User**. This Appendix does not limit any site specific requirements that may be included in a **Bilateral Agreement** where in **NGET's** reasonable opinion these facilities are necessary for system reasons.

CC.A.7.1.2 Proposals by **Generators** to make a change to the voltage control systems are required to be notified to **NGET** under the **Planning Code** (PC.A.1.2(b) and (c)) as soon as the **Generator** anticipates making the change. The change may require a revision to the **Bilateral Agreement**.

CC.A.7.2 Requirements

CC.A.7.2.1 **NGET** requires that the continuously acting automatic voltage control system for the **Non-Synchronous Generating Unit, DC Converter** or **Power Park Module** shall meet the following functional performance specification. If a **Network Operator** has confirmed to **NGET** that its network to which an **Embedded Non-Synchronous Generating Unit, DC Converter** or **Power Park Module** is connected is restricted such that the full reactive range under the steady state voltage control requirements (**CC.A.7.2.2**) cannot be utilised, **NGET** may specify in the **Bilateral Agreement** alternative limits to the steady state voltage control range that reflect these restrictions. Where the **Network Operator** subsequently notifies **NGET** that such restriction has been removed, **NGET** may propose a **Modification** to the **Bilateral Agreement** (in accordance with the **CUSC** contract) to remove the alternative limits such that the continuously acting automatic voltage control system meets the following functional performance specification. All other requirements of the voltage control system will remain as in this Appendix.

CC.A.7.2.2 Steady State Voltage Control

CC.A.7.2.2.1 The **Non-Synchronous Generating Unit, DC Converter** or **Power Park Module** shall provide continuous steady state control of the voltage at the **Grid Entry Point** (or **User System Entry Point** if **Embedded**) with a **Setpoint Voltage** and **Slope** characteristic as illustrated in Figure CC.A.7.2.2a. It should be noted that where the **Reactive Power** capability requirement of a directly connected **Non-Synchronous Generating Unit, DC Converter** or **Power Park Module** in Scotland, as specified in CC.6.3.2 (c), is not at the **Grid Entry Point**, the values of Q_{min} and Q_{max} shown in this figure will be as modified by the 33/132kV or 33/275kV or 33/400kV transformer.

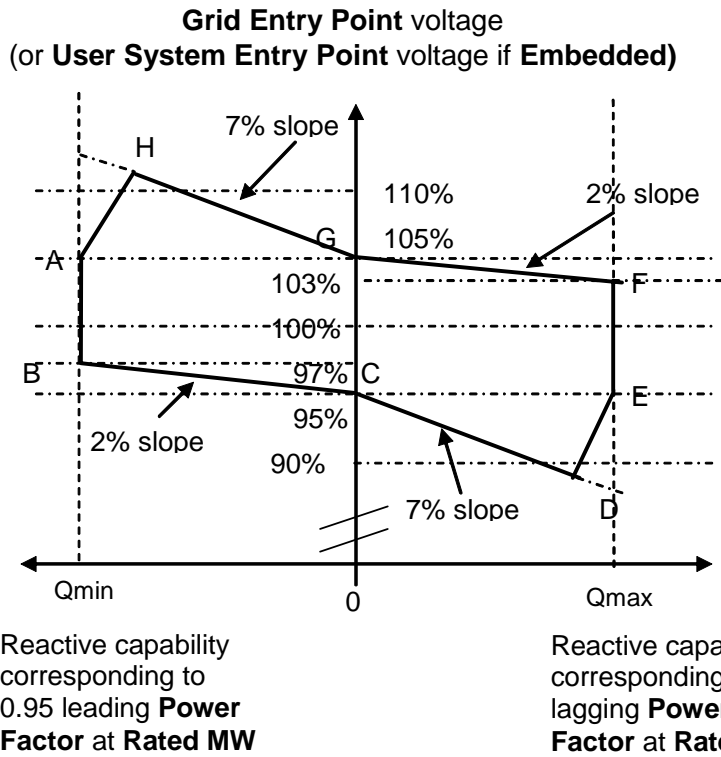

Figure CC.A.7.2.2b

Grid Entry Point Voltage
(or **User System Entry Point voltage if Embedded**)
Connections at 33kV and below

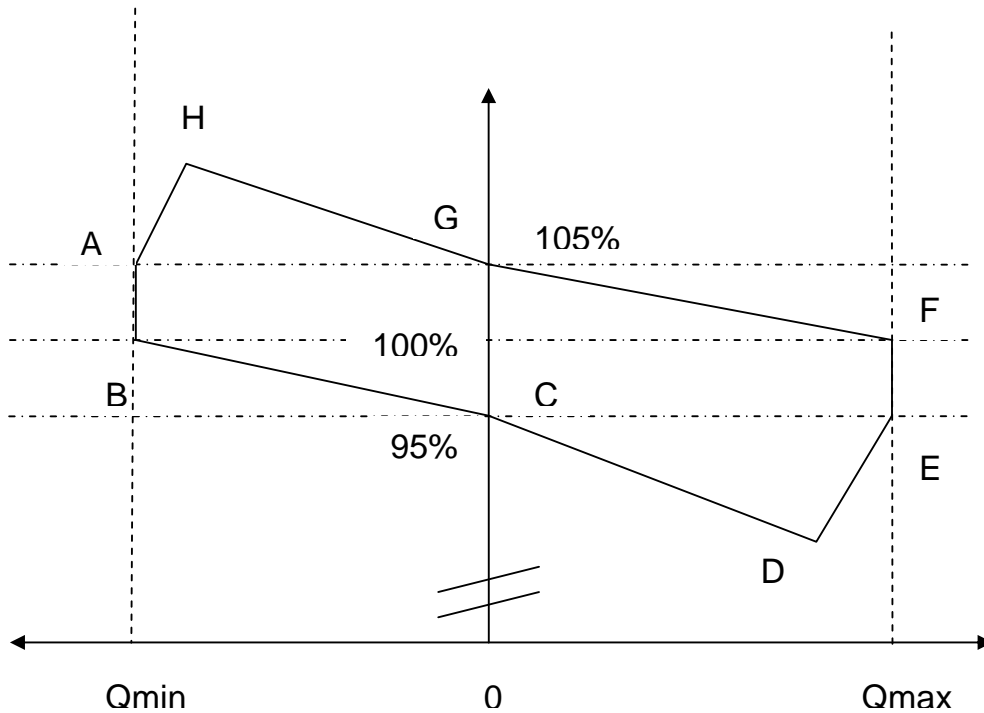

Figure CC.A.7.2.2c

- CC.A.7.2.2.4 Figure CC.A.7.2.2b shows the required envelope of operation for **Non-Synchronous Generating Units, DC Converters and Power Park Modules** except for those **Embedded** at 33kV and below or directly connected to the **GB Transmission System** at 33kV and below. Figure CC.A.7.2.2c shows the required envelope of operation for **Non-Synchronous Generating Units, DC Converters and Power Park Modules Embedded** at 33kV and below or directly connected to the **GB Transmission System** at 33kV and below. Where the **Reactive Power** capability requirement of a directly connected **Non-Synchronous Generating Unit, DC Converter or Power Park Module** in Scotland, as specified in CC6.3.2 (c), is not at the **Grid Entry Point**, the values of Q_{min} and Q_{max} shown in this figure will be as modified by the 33/132kV or 33/275kV or 33/400kV transformer. The enclosed area within points ABCDEFGH is the required capability range within which the **Slope** and **Setpoint Voltage** can be changed.
- CC.A.7.2.2.5 Should the operating point of the **Non-Synchronous Generating Unit, DC Converter or Power Park Module** deviate so that it is no longer a point on the operating characteristic (figure CC.A.7.2.2a) defined by the target **Setpoint Voltage** and **Slope**, the continuously acting automatic voltage control system shall act progressively to return the value to a point on the required characteristic within 5 seconds.
- CC.A.7.2.2.6 Should the **Reactive Power** output of the **Non-Synchronous Generating Unit, DC Converter or Power Park Module** reach its maximum lagging limit at a **Grid Entry Point** voltage (or **User System Entry Point** voltage if **Embedded**) above 95%, the **Non-Synchronous Generating Unit, DC Converter or Power Park Module** shall maintain maximum lagging **Reactive Power** output for voltage reductions down to 95%. This requirement is indicated by the line EF in figures CC.A.7.2.2b and CC.A.7.2.2c. Should the **Reactive Power** output of the **Non-Synchronous Generating Unit, DC Converter or Power Park Module** reach its maximum leading limit at a **Grid Entry Point** voltage (or **User System Entry Point** voltage if **Embedded**) below 105%, the **Non-Synchronous Generating Unit, DC Converter or Power Park Module** shall maintain maximum leading **Reactive Power** output for voltage increases up to 105%. This requirement is indicated by the line AB in figures CC.A.7.2.2b and CC.A.7.2.2c.
- CC.A.7.2.2.7 For **Grid Entry Point** voltages (or **User System Entry Point** voltages if **Embedded**) below 95%, the lagging **Reactive Power** capability of the **Non-Synchronous Generating Unit, DC Converter or Power Park Module** should be that which results from the supply of maximum lagging reactive current whilst ensuring the current remains within design operating limits. An example of the capability is shown by the line DE in figures CC.A.7.2.2b and CC.A.7.2.2c. For **Grid Entry Point** voltages (or **User System Entry Point** voltages if **Embedded**) above 105%, the leading **Reactive Power** capability of the **Non-Synchronous Generating Unit, DC Converter or Power Park Module** should be that which results from the supply of maximum leading reactive current whilst ensuring the current remains within design operating limits. An example of the capability is shown by the line AH in figures CC.A.7.2.2b and CC.A.7.2.2c. Should the **Reactive Power** output of the **Non-Synchronous Generating Unit, DC Converter or Power Park Module** reach its maximum lagging limit at a **Grid Entry Point** voltage (or **User System Entry Point** voltage if **Embedded**) below 95%, the **Non-Synchronous Generating Unit, DC Converter or Power Park Module** shall maintain maximum lagging reactive current output for further voltage decreases. Should the **Reactive Power** output of the **Non-Synchronous Generating Unit, DC Converter or Power Park Module** reach its maximum leading limit at a **Grid Entry Point** voltage (or **User System Entry Point** voltage if **Embedded**) above 105%, the **Non-Synchronous Generating Unit, DC Converter or Power Park Module** shall maintain maximum leading reactive current output for further voltage increases.

CC.A.7.2.3 Transient Voltage Control

CC.A.7.2.3.1 For an on-load step change in **Grid Entry Point** or **User System Entry Point** voltage, the continuously acting automatic control system shall respond according to the following minimum criteria

- i. the **Reactive Power** output response of the **Non-Synchronous Generating Unit, DC Converter** or **Power Park Module** shall commence within 0.2 seconds of the application of the step. It shall progress linearly although variations from a linear characteristic shall be acceptable provided that the MVAR seconds delivered at any time up to 1 second are at least those that would result from the response shown in figure CC.A.7.2.3.1a.
- ii. the response shall be such that, for a sufficiently large step, 90% of the full reactive capability of the **Non-Synchronous Generating Unit, DC Converter** or **Power Park Module**, as required by **CC.6.3.2** (or, if appropriate, **CC.A.7.2.2.6** or **CC.A.7.2.2.7**), will be produced within 1 second
- iii. the magnitude of the **Reactive Power** output response produced within 1 second shall vary linearly in proportion to the magnitude of the step change
- iv. the settling time shall be no greater than 2 seconds from the application of the step change in voltage and the peak to peak magnitude of any oscillations shall be less than 5% of the change in steady state **Reactive Power** within this time.
- v. following the transient response, the conditions of CC.A.7.2.2 apply.

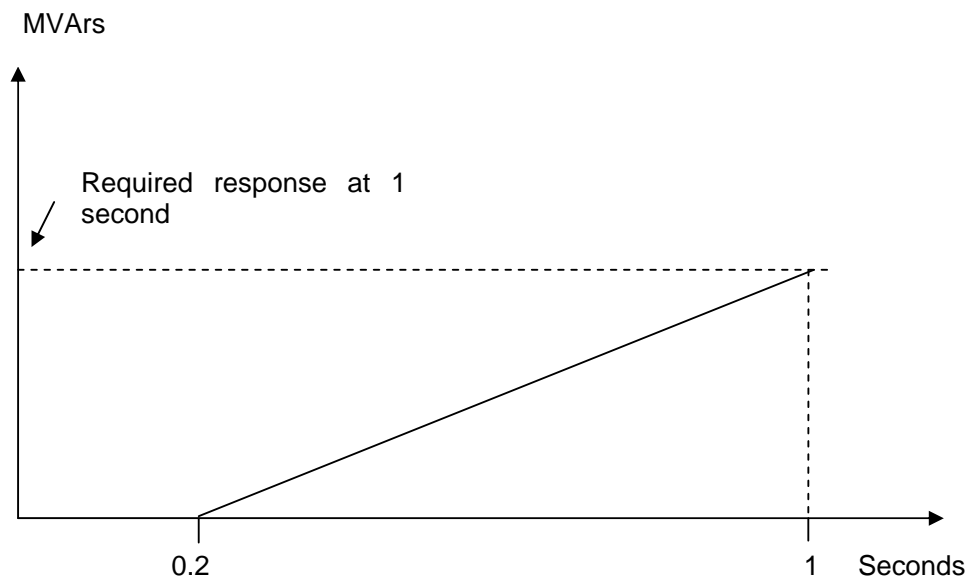

Figure CC.A.7.2.3.1a

CC.A.7.2.4 Power Oscillation Damping

CC.A.7.2.4.1 The requirement for the continuously acting voltage control system to be fitted with a **Power System Stabiliser (PSS)** shall be specified in the **Bilateral Agreement** if, in **NGET's** view, this is required for system reasons. However if a **Power System Stabiliser** is included in the voltage control system its settings and performance shall be agreed with **NGET** and commissioned in accordance with **BC.2.11.2**.

CC.A.7.2.5 Overall Voltage Control System Characteristics

- CC.A.7.2.5.1 The continuously acting automatic voltage control system is required to respond to minor variations, steps, gradual changes or major variations in **Grid Entry Point** voltage (or **User System Entry Point** voltage if **Embedded**).
- CC.A.7.2.5.2 The overall voltage control system shall include elements that limit the bandwidth of the output signal. The bandwidth limiting must be consistent with the speed of response requirements and ensure that the highest frequency of response cannot excite torsional oscillations on other plant connected to the network. A bandwidth of 0-5Hz would be judged to be acceptable for this application. All other control systems employed within the **Non-Synchronous Generating Unit, DC Converter** or **Power Park Module** should also meet this requirement
- CC.A.7.2.5.3 The response of the voltage control system (including the **Power System Stabiliser** if employed) shall be demonstrated by applying suitable step disturbances into the voltage control system of the **Power Park Module** or **Power Park Unit**, or by changing the actual voltage at a suitable point, with the generator operating at points specified by **NGET** (up to rated MVA output). The damping shall be judged to be adequate if the corresponding **Active Power** response to the disturbances decays within 2 seconds of the application of the step.

< End of CC >

BC3.6.2 Low Frequency Relay Initiated Response from Demand and other Demand modification arrangements (which may include a DC Converter Station when importing Active Power from the Total System)

- (a) **NGET** may, pursuant to an **Ancillary Services Agreement**, utilise **Demand** with the capability of **Low Frequency Relay** initiated **Demand** reduction in establishing its requirements for **Frequency Control**.
- (b)
 - (i) **NGET** will specify within the range agreed the **Low Frequency Relay** settings to be applied pursuant to BC3.6.2 (a), the amount of **Demand** reduction to be available and will instruct the **Low Frequency Relay** initiated response to be placed in or out of service.
 - (ii) **Users** will comply with **NGET** instructions for **Low Frequency Relay** settings and **Low Frequency Relay** initiated **Demand** reduction to be placed in or out of service. **Users** may not alter such **Low Frequency Relay** settings or take **Low Frequency Relay** initiated response out of service without **NGET's** agreement, except for safety reasons.
 - (iii) In the case of any such **Demand** which is **Embedded**, **NGET** will notify the relevant **Network Operator** of the location of the **Demand**, the amount of **Demand** reduction to be available, and the **Low Frequency Relay** settings.
- (c) **NGET** may also utilise other **Demand** modification arrangements pursuant to an agreement for **Ancillary Services**, in order to contribute towards **Operating Reserve**.

BC3.7 RESPONSE TO HIGH FREQUENCY REQUIRED FROM SYNCHRONISED GENSETS (AND DC CONVERTERS AT DC CONVERTER STATIONS WHEN TRANSFERRING ACTIVE POWER TO THE TOTAL SYSTEM)

BC3.7.1 Plant in Frequency Sensitive Mode instructed to provide High Frequency Response

- (a) Each **Synchronised Genset** (or each **DC Converter** at a **DC Converter Station**) in respect of which the **Generator** or **DC Converter Station** owner and/or **EISO** has been instructed to operate so as to provide **High Frequency Response**, which is producing **Active Power** and which is operating above the **Designed Minimum Operating Level**, is required to reduce **Active Power** output in response to an increase in **System Frequency** above the **Target Frequency** (or such other level of **Frequency** as may have been agreed in an **Ancillary Services Agreement**). The **Target Frequency** is normally 50.00 Hz except where modified as specified under BC3.4.2.
- (b)
 - (i) The rate of change of **Active Power** output with respect to **Frequency** up to 50.5 Hz shall be in accordance with the provisions of the relevant **Ancillary Services Agreement** with each **Generator** or **DC Converter Station** owner. If more than one rate is provided for in the **Ancillary Services Agreement** **NGET** will instruct the rate when the instruction to operate to provide **High Frequency Response** is given.

- (ii) The reduction in **Active Power** output by the amount provided for in the relevant **Ancillary Services Agreement** must be fully achieved within 10 seconds of the time of the **Frequency** increase and must be sustained at no lesser reduction thereafter.
 - (iii) It is accepted that the reduction in **Active Power** output may not be to below the **Designed Minimum Operating Level**.
- (c) In addition to the **High Frequency Response** provided, the **Genset** (or **DC Converter** at a **DC Converter Station**) must continue to reduce **Active Power** output in response to an increase in **System Frequency** to above 50.5 Hz at a minimum rate of 2 per cent of output per 0.1 Hz deviation of **System Frequency** above that level, such reduction to be achieved within five minutes of the rise to or above 50.5 Hz. For a **Power Station** with a **Completion Date** after 1st January 2009 this reduction in **Active Power** should be delivered in accordance with in (i) to (iv) below. For the avoidance of doubt, the provision of this reduction in **Active Power** output is not an **Ancillary Service**.
- (i) The reduction in **Active Power** output must be continuously and linearly proportional as far as practical, to the excess of **Frequency** above 50.5 Hz and must be provided increasingly with time over the period specified in (iii) below.
 - (ii) As much as possible of the proportional reduction in **Active Power** output must result from the frequency control device (or speed governor) action and must be achieved within 10 seconds of the time of the **Frequency** increase above 50.5 Hz.
 - (iii) The residue of the proportional reduction in **Active Power** output which results from automatic action of the **Genset** (or **DC Converter** at a **DC Converter Station**) output control devices other than the frequency control devices (or speed governors) must be achieved within 3 minutes from the time of the **Frequency** increase above 50.5 Hz.
 - (iv) Any further residue of the proportional reduction which results from non-automatic action initiated by the **Generator** or **DC Converter Station** owner shall be initiated within 2 minutes, and achieved within 5 minutes, of the time of the **Frequency** increase above 50.5 Hz.

BC3.7.2 Plant in Limited Frequency Sensitive Mode

- (a) Each **Synchronised Genset** (or **DC Converter** at a **DC Converter Station**) operating in a **Limited Frequency Sensitive Mode** which is producing **Active Power** is also required to reduce **Active Power** output in response to **System Frequency** when this rises above 50.4 Hz. In the case of **DC Converters** at **DC Converter Stations**, the provisions of **BC.3.7.7** are also applicable. For the avoidance of doubt, the provision of this reduction in **Active Power** output is not an **Ancillary Service**. Such provision is known as "**Limited High Frequency Response**".

- (b) (i) The rate of change of **Active Power** output must be at a minimum rate of 2 per cent of output per 0.1 Hz deviation of **System Frequency** above 50.4 Hz.
- (ii) The reduction in **Active Power** output must be continuously and linearly proportional, as far as is practicable, to the excess of **Frequency** above 50.4 Hz and must be provided increasingly with time over the period specified in (iii) below.
- (iii) As much as possible of the proportional reduction in **Active Power** output must result from the frequency control device (or speed governor) action and must be achieved within 10 seconds of the time of the **Frequency** increase above 50.4 Hz.
- (iv) The residue of the proportional reduction in **Active Power** output which results from automatic action of the **Genset** (or **DC Converter** at a **DC Converter Station**) output control devices other than the frequency control devices (or speed governors) must be achieved within 3 minutes from the time of the **Frequency** increase above 50.4 Hz.
- (v) Any further residue of the proportional reduction which results from non-automatic action initiated by the **Generator** or **DC Converter Station** owner shall be initiated within 2 minutes, and achieved within 5 minutes, of the time of the **Frequency** increase above 50.4 Hz.
- (c) Each **Genset** (or **DC Converter** at a **DC Converter Station**) which is providing **Limited High Frequency Response** in accordance with this BC3.7.2 must continue to provide it until the **Frequency** has returned to or below 50.4 Hz or until otherwise instructed by **NGET**.

BC3.7.3 Plant operation to below **Minimum Generation**

- (a) As stated in CC.A.3.2, steady state operation below **Minimum Generation** is not expected but if **System** operating conditions cause operation below **Minimum Generation** which give rise to operational difficulties for the **Genset** (or **DC Converter** at a **DC Converter Station**) then **NGET** should not, upon request, unreasonably withhold issuing a **Bid-Offer Acceptance** to return the **Generating Unit** or **CCGT Module** or **Power Park Module** or **DC Converter** to an output not less than **Minimum Generation**. In the case of a **DC Converter** not participating in the **Balancing Mechanism**, then **NGET** will, upon request, attempt to return the **DC Converter** to an output not less than **Minimum Generation** or to zero transfer or to reverse the transfer of **Active Power**.
- (b) It is possible that a **Synchronised Genset** (or a **DC Converter** at a **DC Converter Station**) which responded as required under BC3.7.1 or BC3.7.2 to an excess of **System Frequency**, as therein described, will (if the output reduction is large or if the **Genset** (or a **DC Converter** at a **DC Converter Station**) output has reduced to below the **Designed Minimum Operating Level**) trip after a time.

- (c) All reasonable efforts should in the event be made by the **Generator** or **DC Converter Station** owner to avoid such tripping, provided that the **System Frequency** is below 52Hz.
- (d) If the **System Frequency** is at or above 52Hz, the requirement to make all reasonable efforts to avoid tripping does not apply and the **Generator** or **DC Converter Station** owner is required to take action to protect the **Generating Units, Power Park Modules** or **DC Converters** as specified in CC.6.3.13.
- (e) In the event of the **System Frequency** becoming stable above 50.5Hz, after all **Genset** and **DC Converter** action as specified in BC3.7.1 and BC3.7.2 has taken place, **NGET** will issue appropriate **Bid-Offer Acceptances** and/or **Ancillary Service** instructions, which may include **Emergency Instructions** under **BC2** to trip **Gensets** (or, in the case of **DC Converters** at **DC Converter Stations**, to stop or reverse the transfer of **Active Power**) so that the **Frequency** returns to below 50.5Hz and ultimately to **Target Frequency**.
- (f) If the **System Frequency** has become stable above 52 Hz, after all **Genset** and **DC Converter** action as specified in BC3.7.1 and BC3.7.2 has taken place, **NGET** will issue **Emergency Instructions** under **BC2** to trip appropriate **Gensets** (or in the case of **DC Converters** at **DC Converter Stations** to stop or reverse the transfer of **Active Power**) to bring the **System Frequency** to below 52Hz and follow this with appropriate **Bid-Offer Acceptances** or **Ancillary Service** instructions or further **Emergency Instructions** under **BC2** to return the **System Frequency** to below 50.5 Hz and ultimately to **Target Frequency**.

BC3.7.4 The **Generator** or **DC Converter Station** owner will not be in breach of any of the provisions of BC2 by following the provisions of BC3.7.1, BC3.7.2 or BC3.7.3.

BC3.7.5 Information update to NGET
 In order that **NGET** can deal with the emergency conditions effectively, it needs as much up to date information as possible and accordingly **NGET** must be informed of the action taken in accordance with BC3.7.1(c) and BC3.7.2 as soon as possible and in any event within 7 minutes of the rise in **System Frequency**, directly by telephone from the **Control Point** for the **Power Station** or **DC Converter Station**.

BC3.7.6 (a) Existing Gas Cooled Reactor Plant
 For the avoidance of doubt, **Generating Units** within **Existing Gas Cooled Reactor Plant** are required to comply with the applicable provisions of this BC3.7 (which, for the avoidance of doubt, other than for **Frequency Sensitive AGR Units**, do not include BC3.7.1).

(b) Power Park Modules in operation before 1 January 2006.
 For the avoidance of doubt, **Power Park Modules** in operation (irrespective of their **Completion Dates**) before 1 January 2006 are required to comply with the applicable provisions of this BC3.7 (which, for the avoidance of doubt do not include BC3.7.1).

BC3.7.7 Externally Interconnected System Operators
NGET will use reasonable endeavours to ensure that, if **System Frequency** rises above 50.4Hz, and an **Externally Interconnected System Operator** (in its role as operator of the **External System**) is transferring power into the **GB**

Transmission System from its **External System**, the amount of power transferred in to the **GB Transmission System** from the **System** of that **Externally Interconnected System Operator** is reduced at a rate equivalent to (or greater than) that which applies for **Synchronised Gensets** operating in **Limited Frequency Sensitive Mode** which are producing **Active Power**. This will be done either by utilising existing arrangements which are designed to achieve this, or by issuing **Emergency Instructions** under **BC2**.

< End of BC3 >

CODE	PAGE	CLAUSE
	44	Schedule 10, page 2: Table page 2 amended
	45	Schedule 11: Clause on page 1 added
	48	Schedule 12: Clause on page 2 added
	49	Schedule 13: Table page 1 amended
	50-52	Schedule 14: Table pages 1-3 amended
	56	Schedule 15: Clause on page 3 added
	57	Schedule 16: Clause on page 1 added
	58	Schedule 17: Clause on page 1 added

Revision 32

Effective Date: 8 December 2008

CODE	PAGE	CLAUSE
G&D	11	Definition of Droop amended.
PC	48	PC.A.5.3.2 (c) Option 2 Clause amended.
	50	PC.A.5.3.2 (d) (i) Option 2 Clause amended.
	53	PC.A.5.4.2 (a) Clause amended
CC	66-67	CC.A.6.2.5.3 Clause amended.
	67	CC.A.6.2.5.4 Clause amended.
	67	CC.A.6.2.5.7 Clause added.
	67	CC.A.6.2.5.8 Clause added.
BC3	6	BC3.7.1 Clause amended.