

Reintroduction of aggregation at GSP Group for DC

January 2022



Contents

Overview..... 3

Considerations when making this decision..... 3

Stakeholder Engagement 4

Other considerations..... 5

Next steps..... 5

Appendix A: Visibility of aggregated assets..... 8

Overview

On 1 October 2020, we soft-launched the new Dynamic Containment (DC) frequency response service with sub-second, post-fault response capability. The soft launch approach gave us the opportunity to deliver a service quickly (delivering DC Low Frequency (DCL) to respond to the operational need to mitigate large generation losses, introduce sprint delivery in product design, and align developments with stakeholder feedback. Along with launching the first new response product, we also took a significant step in our market reform activities by introducing day ahead procurement, running daily tenders for DC (seven days a week) and launching DC High Frequency (DCH) on 1 November 2021.

For the launch of the service, a number of transitional arrangements were put in place to allow us to quickly deliver DCL and grow the volume to meet the operational need, whilst committing to engage with industry on the more complex arrangements to understand the blockers, and seek alternative solutions, where possible. For GSP, a transitional arrangement was put in place for a period of 12 months where aggregation of Eligible Assets to a Response Unit shall be permitted at GSP Group level. Following this period, aggregation would be limited to Eligible Assets at GSP level only. This came into effect on 1 October 2021.

Through direct engagement with providers following the launch of DC and via industry forums, providers highlighted aspects of the DC service design that created barriers to entry, one of which was GSP aggregation. As we continue to reform our markets, we are introducing new services for response: Dynamic Moderation (DM) and Dynamic Regulation (DR). **These services will allow aggregation at GSP Group.**

We have further reviewed the risks related to aggregating at GSP Group for DC. **Following this review, we propose to re-instate aggregation at GSP Group as soon as possible.** To facilitate this, we will be engaging with industry to help implement improved mapping abilities for individual assets that form aggregated units, this will include asking participants to provide additional information about the location of individual units. We will also be exploring other options to improve visibility with aggregators, increasing monitoring of units aggregated at GSP Group, and exploring the level at which a cap on the overall volume of aggregated units could be set. A full list of actions we need to complete to enable the aggregation of DC at GSP Group level is set out in the 'next steps' section of this document.

This paper explains the considerations we have taken into account to make this decision, what we're planning to do to mitigate any operational risks, and the timetable for bringing aggregation at GSP Group back for DC.

Considerations when making this decision

Since the removal of aggregation at GSP Group from DC we have been engaging with industry on its reintroduction. We recognise that aggregation will play an important role in the future provision of ancillary services, and we believe the decision to reintroduce this will be beneficial. When assessing the impact of our decision, we looked at potential forecasts of volume we may exclude from the market including some key analysis from Future Energy Scenarios (FES) 2020 which stated:

- V2G (as an example) could provide volume of over 1 GW by 2030 and 38GW by 2050 from electric vehicles. This aggregated volume has the potential to participate in future markets. There will also be 2.5GW of industrial and commercial Demand Side Response (DSR) by 2025, and 13GW by 2050.
- Interconnectors are also expected to grow from between 16 GW – 21 GW. DC high will be required to mitigate these larger demand losses therefore the ability to manage this through providing response is even more important.
- We are also expected to see a large decline in thermal plant, with FES expecting 10GW closures by 2030. As large thermal plants decline, being able to respond quickly to any frequency deviations due to losses on the system will be even more important to keep the system stable.

Alongside this, providers were optimistic that we would see aggregated volumes increasing in the near future with several companies commenting that allowing aggregation at GSP Group for DC would provide a signal for new assets to come forward to participate in DC.

Additionally, we will soon be launching DM and DR which will both allow aggregation at GSP Group from the dates these products go-live. Assets that can participate in DC should also be able to participate in DM due to

it having a similar service design. We assume that all batteries from Enhanced Frequency Response (EFR), Firm Frequency Response (FFR) Dynamic, and DLH market could participate in DC or DM. Non-batteries from FFR Dynamic, DLH market and MFR could participate in DR.

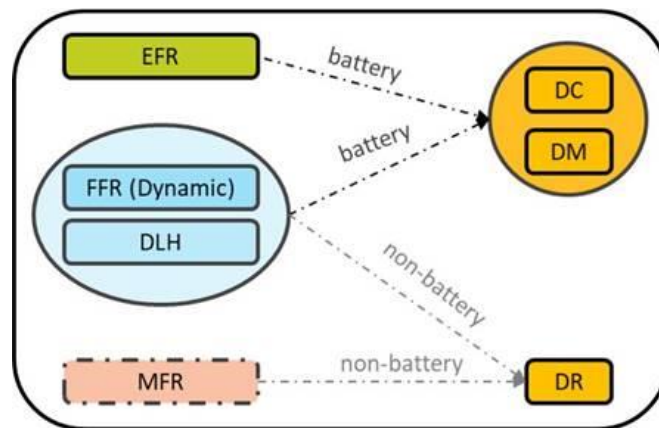

In order to support National Control, we recognise that additional tools and processes will be needed to manage a system with higher levels of aggregation. With the help of a mapping tool to identify the location of individual assets that form aggregated units, additional monitoring to help us understand how units aggregated at GSP behave and caps on overall volume aggregated units, we are confident that we can reduce risks related to system operation. With volumes of aggregated assets forecast to continue to increase in the future, we consider that NGENSO needs to manage these risks and continue to improve how we manage these assets prior to the balancing services reform being completed.

As part of our RIIO-2 Business Plan we committed to numerous developments of control room infrastructure and architecture in order to allow us to accommodate a more decentralised system with increasing amounts of low carbon technology. As part of our move to operating a zero-carbon network, we are developing solutions to allow us to have better visibility of Distributed Energy Resources (DERs) which would have allowed us to remove this requirement. Following our risk review, we believe we can move to GSP Group aggregation ahead of these developments and are committed to working with industry to find non-control room solutions ahead of this that could accommodate aggregation more widely and provide the ESO with the stability and security we need. Appendix A provides more details of the issues reduced visibility has for operation the system and provides some worked examples.

Stakeholder Engagement

Over the last 15 months we have extensively engaged with industry on the service design and requirements for the DC frequency response product. This has been prior to the launch of the service and subsequently as we have sought to make improvements and develop the service further. We have been looking at GSP requirements since the initial engagement of launching new response services.

The below timeline shows activities and decisions from our initial engagement of DC until the end of the transitional arrangement in place for GSP aggregation. The information used to make our internal decision on GSP in June 2021 was a combination our operations risks listed in our requirements section within this paper and our assessment of the external impact of this decision with the information we had available.

A timeline of events:

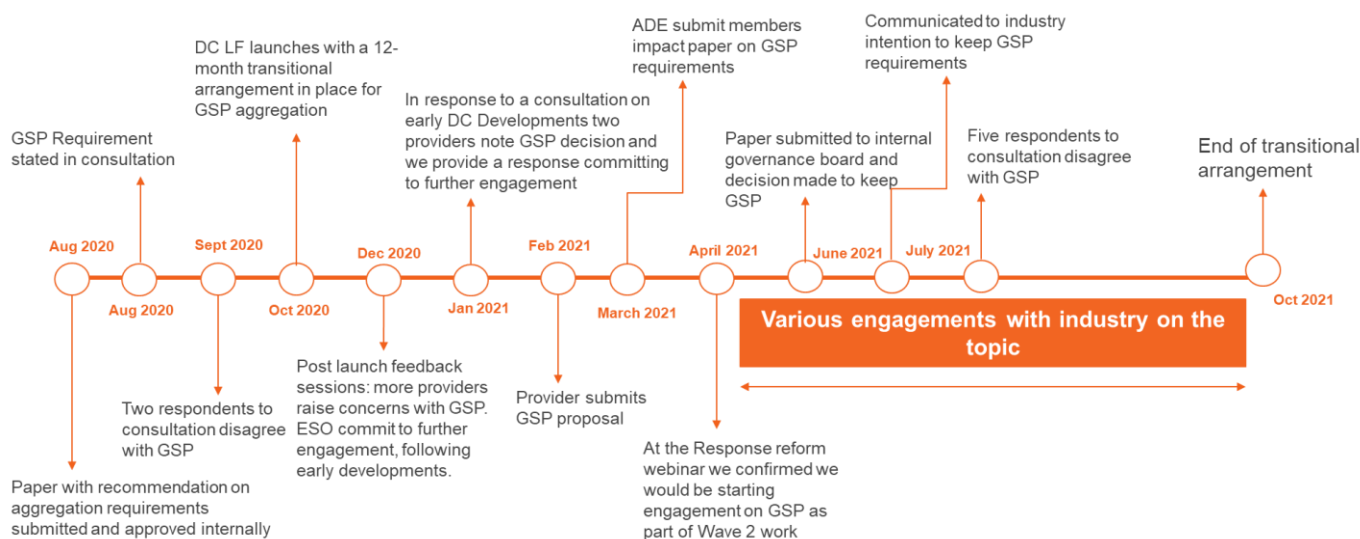

Our engagement with industry has meant that we have listened to what the existing blockers are for participation in these services, allowing us to implement new products (DM and DR) that reduce barriers to entry and increase market participation. This has also meant that we were aware of the need to revisit our decision on aggregation for DC following the end of the transitional arrangements to put steps in place to re-introduce aggregation at GSP group.

Other considerations

Another area that had been discussed was to remove the 1MW minimum threshold to participate. Some providers had asked if we could remove the minimum of 1MW for entry into services as this could help remove a barrier to entry. This was a focus area at the Issue 94 Elexon Group¹. Internal work was completed on this to evaluate the impacts and it was concluded this would not be feasible as yet.

The existing IT control room systems are unable to allow decimal place entry. Our balancing services reform will make significant changes to our systems and ways of working which will deliver improvements to the services we offer and help set us up for the future. These include updates to our systems for access to the Balancing Mechanism (BM), particularly for smaller units. We anticipate that this transformation programme will be delivered by 2025. Sub 1MW and decimals are expected to be fed into the design set for the new tools.

Next steps

We understand that allowing units to be aggregated at GSP Group for DC will remove a significant barrier for market participants. In order to reintroduce this, we will be engaging with industry to explore what other information is available that will help mitigate the issues highlighted in the paper.

Our specific next steps include:

- **System studies and monitoring:** We are currently in the process of undertaking preliminary system studies, specifically on DR, to determine whether the addition of this product will introduce any unwanted oscillations or instability in the system. These studies will check if DR will dampen or amplify any oscillation arising from the regional variation of frequency. We expect an internal report of our findings to be completed this quarter. We will monitor units aggregated at GSP Group to ensure no unexpected operational issues arise.

¹ <https://www.elexon.co.uk/smg-issue/issue-94/>

- **GSP data:** In this quarter, we will start engaging with providers to ask for visibility of aggregated assets for DM/DR. We will ask participants to provide GSP locations of individual assets that form aggregated units.
- **Industry collaboration:** In this quarter, we will also start engaging with aggregators to understand what other data is available to further support NGENSO in providing visibility of assets providing ancillary services.
- **Mapping tool:** Based on the above, NGENSO will develop a mapping tool for the control room that will allow us to identify where aggregated assets are located for DM and DR. The objective of the mapping exercise is to generate an Aggregator Impact Matrix (AIM) for each aggregated unit. AIM provides the distribution of an aggregated assets across GSPs and help control room to manage constraints. The input of the mapping tool is a dataset containing postcodes of each subunit, the mapping tool will then convert postcodes to pairs of latitude and longitude and match each postcode with its nearest GSP (in terms of geographical distance). This mapping exercise can be used as an interim tool to assist any relevant studies in the short term. While proceeding with this mapping tool, we will also explore an ultimate solution in the long term.

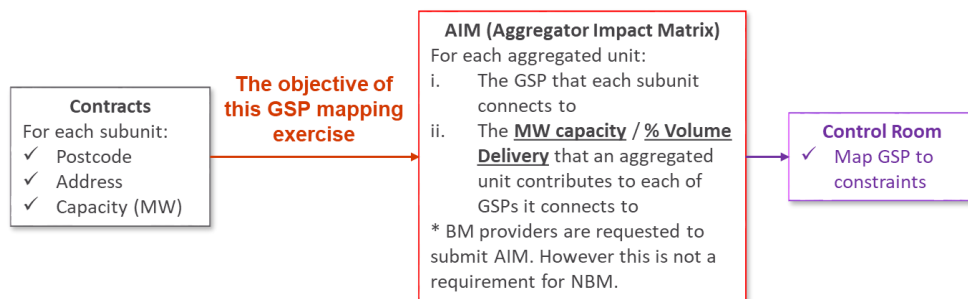

Figure 1: GSP Mapping Exercise – Objectives

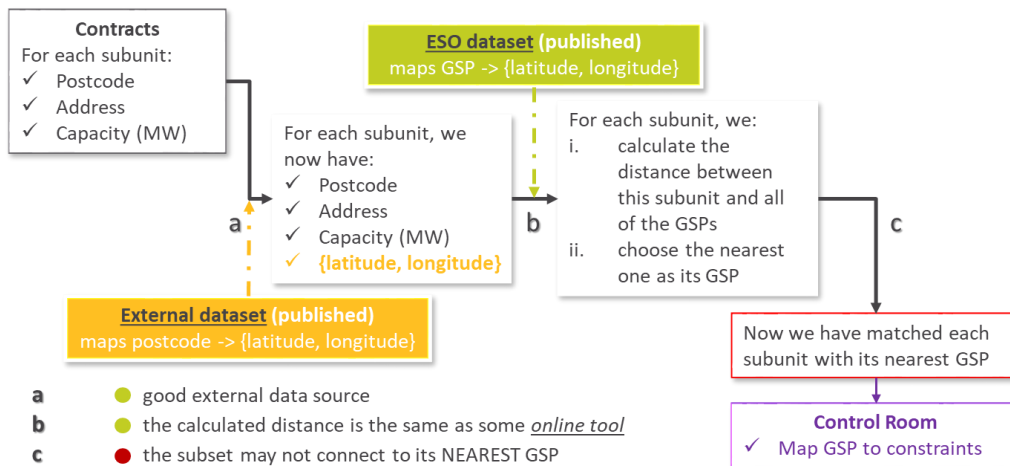
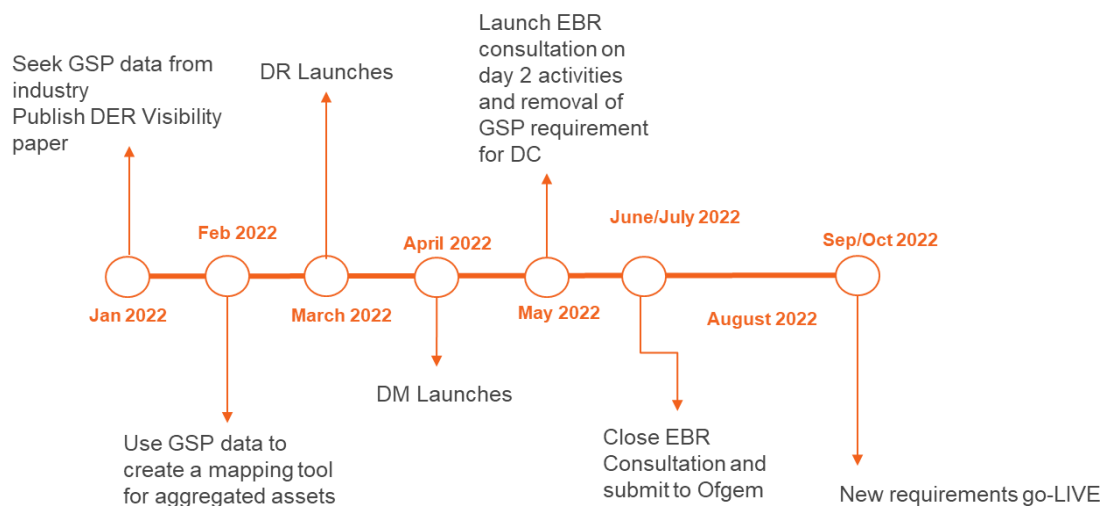

Figure 2: GSP Mapping Exercise - Methodology

- **Reintroduction of GSP Group:** We will consider what other tools are needed to ensure we reduce risk with the remove the GSP requirement for DC. This could include an overall volume cap for aggregated units as well as increased monitoring of units aggregated at GSP Group. We would then progress the move to aggregation at GSP group as part of an EBGL consultation. This would include other 'day 2' items that we will be implementing to product designs which require an EBGL consultation.

Future timeline:



Further to this, we intend to create a more structured process to progress outstanding issues (such as the aggregation at GSP Group issue). This will be set up in conjunction with industry, where key topics can be discussed, progressed and implemented.

The ESO is also publishing a position paper in early 2022 on the need of greater visibility of DER. This paper will discuss the benefits of greater visibility across a range of potential use cases including provision of balancing services and will provide a roadmap to signal requirements for industry. The paper will also tie in with other ongoing initiatives in this area including the ENA Open Networks project².

We welcome further conversations with industry on how we best solve these operational challenges and take them forward. If you would like to discuss this paper in more detail or have any feedback you can reach the team at box.futureofbalancingservices@nationalgrideso.com.

² [on21-ws1b-p6-operational-der-visibility-use-cases-and-volumes-\(30-jul-2021\).pdf \(energynetworks.org\)](#)

Appendix A - Visibility of aggregated assets

The examples below show the different risks that ENCC needs to manage to ensure stability of the GB power system. Low visibility of aggregated assets makes managing these risks more difficult, the mitigation actions we’re taking along with the new tools, volume caps, and enhanced monitoring of aggregated units will provide us with the tools that will allow us to operate these services at an expectable level of risk.

Worked examples

- Network Fault:** If the response is at the same location as a large loss it may not be able to contribute to the security/recovery of that loss (and therefore we may not be secure & compliant). The amount of DC available is used in the modelling of Frequency Risk and Control Report (FRCR) to determine the likelihood of a frequency deviation below 49.2Hz or above 50.5Hz for network faults BM + Vector Shift (VS)). If DC is cut off as part of the same network fault, this will increase the probability of an “unsecured event”. Having GSP knowledge of location allows NGENSO to better account for this in assessing the total level of risk. With GSP group aggregation, the amount of a service is not known at each GSP.

The diagrams below show the impact GSP can have on the system when there is a network fault.

Diagram 1: Pre-fault Condition. The combined output of Generator 1 and 2 are limited to the line limits, plus any demand within the constraint. Generator 1 is armed on intertrip, which means it will trip if either Line A or Line B trips, so that the flow down the remaining line stays within limits. A 50MW unit has been awarded a DC contract for delivery, the unit is aggregated at GSP-group. The configuration of this unit today is that 30MW of delivery will be at GSP 3, with the other 20MW distributed across the rest of the GSP group.

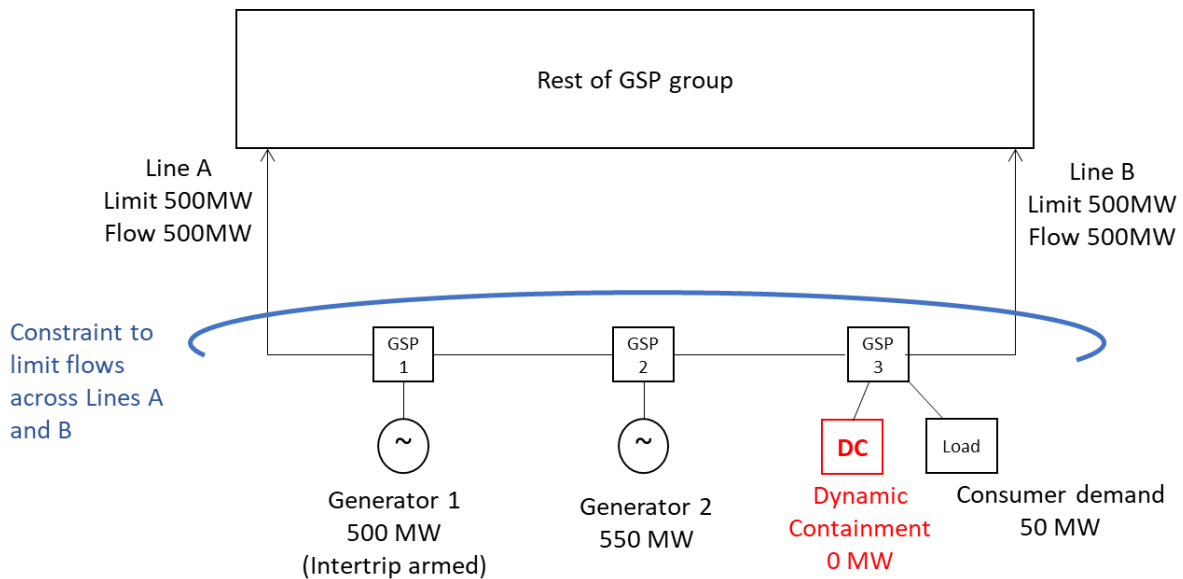
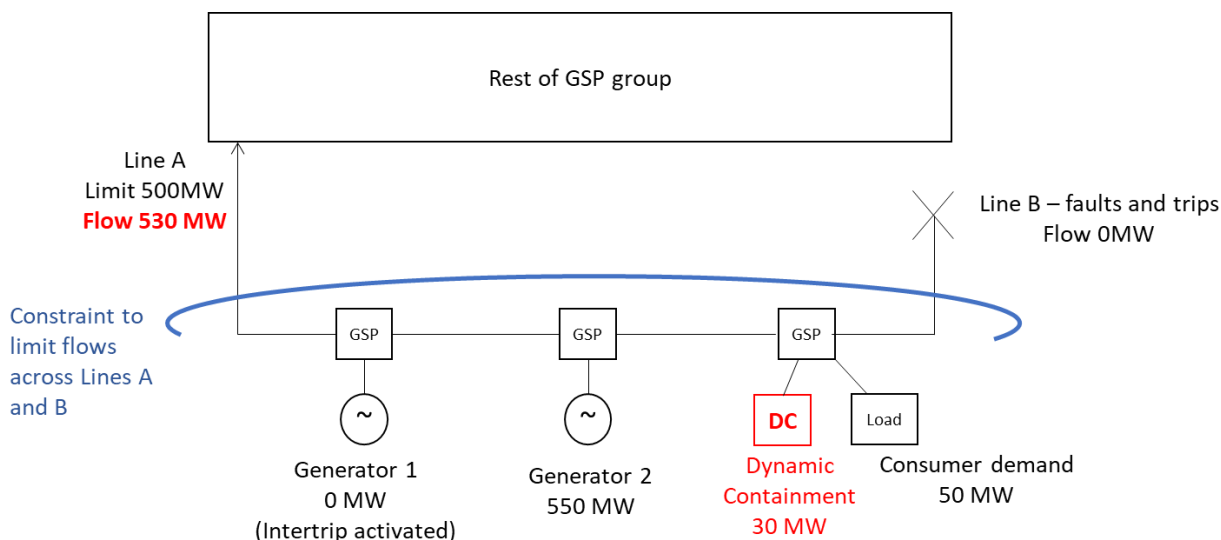

Diagram 2: Post-fault condition. Line B trips. The intertrip is activated on Generator 1 causing it to deload to 0MW. Because the system has lost 500MW, the frequency drops causing the dynamic containment to activate. Without knowing that it was delivering at one of these three constrained GSPs, the line flow on the remaining line exceeds its rating (unacceptable overloading under SQSS). It then trips on protection, disconnecting all three GSPs.

This results in losing the remaining 550MW generator (total 1050MW lost) and disconnecting 50MW of consumer demand. 30MW of DC is also disconnected, and therefore unable to contribute to securing further faults.



- Network Fault:** If the response is located behind a constraint, activation of the service may breach the constraint. This is likely to happen as network faults currently also trigger VS loss. This will lead to a low frequency and cause DC-LF to activate. An example of this is HUMKEAEX (covers Humber group and cuts across Creyke Beck and Keadby), where this is a stability constraint. If the group is operating at the limit, and a network fault occurs, and DC is within the group then the post fault flow will be over the limit. This could lead to generators tripping to avoid pole slipping³, and/or potential breach of the SQSS⁴ and/or a safety issue. Having GSP aggregation gives NGENSO certainty of whether a service will deliver within a transmission constraint. Mitigating actions (through our Balancing options such as the Balancing Mechanism) can then be taken to ensure sufficient margin is maintained within such a constraint for activation of the service to take place safely. With GSP group aggregation, it is not known whether units will deliver within a constraint or not, and to what degree. This leaves a decision of whether to not mitigate and accept increased risk, or to mitigate against all possible constraints in that GSP-group, leading to inefficient running (as the mitigations taken may not be needed).
- Wider Constraints:** This is also true of general, wider constraints on the system like SSHARN3 (North of England near Heysham south of the Angloscottish boundary), SEIMP (covers London and south coast), SWALEX (Covers Wales, Cotswold and Bristol (excluding the south west)), most/all of which do not follow the geographic boundaries of the Distribution Network Operator (DNO) networks; this means they do not align to GSP groups.
- Changes to constraints:** These large losses and constraints are not fixed, they can and do change over the course of a day and therefore it may not be possible to perfectly 'filter' out units in a day-ahead auction. Equally, faults can occur within day which can in turn introduce new constraints.
- Frequency Oscillation:** When considering the design of national frequency response products, it is also important to consider the regional effects that activation of the services may produce. For instance, units aggregated at GSP group may move delivery of the service within the aggregated zone. This may mean that in parts of the area, the service delivery may not be acting to restore the local frequency to 50Hz, but may actually be acting in a reinforcement direction, leading to worse local frequency deviations. It has been observed that local frequencies can vary after a generation loss, with Scotland observing a higher rate of change of frequency that the south-east for an interconnector trip. It is important for such fast-acting response products to be acting in a direction that assists the return of frequency to the target frequency (in general 50Hz).

³ If electrical conditions during an electrical fault are not managed pre-fault, generators can find the electrical stress too much to remain synchronised to the grid. This can lead to a dangerous situation known as pole-slip, and in practice if a risk of this is detected then a generator is likely to protectively trip in order to avoid such a situation.

⁴ The Security and Quality of Supply Standard sets out the criteria and methodology for planning and operating the National Electricity Transmission System (NETS).