

Grid Code Modification Proposal Form

GC0155: Clarification of Fault Ride Through Technical Requirements

Overview: An alternative to GC0151 which addressed the Fault Ride Through (FRT) compliance process and proposed minor improvements to the FRT technical requirements. This alternative was insufficiently scrutinised as part of the GC0151 urgent modification process hence Ofgem, while rejecting it in their decision letter dated 8 November 2021, noted that it had merit and should be brought forward subsequently.

Modification process & timetable



Status summary: The Proposer has raised a modification and is seeking a decision from the Panel on the governance route to be taken.

This modification is expected to have a: **Medium impact** on Generators, Transmission System Operators, Interconnectors, Transmission Owners, Distribution Owners

Modification drivers: GB Compliance, Ofgem-led Code Review, System Operability, System Security, Efficiency, New Technologies

Proposer's recommendation of governance route	Standard Governance modification with assessment by a Workgroup
------------------------------------------------------	-----------------------------------------------------------------

Who can I talk to about the change?	Proposer: Terry Baldwin Terry.Baldwin@nationalgrideso.com 07814778118	Code Administrator Contact: Banke John-Okwesa Banke.john-okwesa@nationalgrideso.com 07929716301
--------------------------------------------	----------------------------------------------------------------------------------------------------------------------------------------------	----------------------------------------------------------------------------------------------------------------------------------------------------------------------------

Contents

Contents	2
What is the issue?	3
Why change?	3
What is the proposer's solution?	3
Draft legal text	12
What is the impact of this change?	12
Proposer's assessment against Grid Code Objectives	12
Proposer's assessment of the impact of the modification on the stakeholder / consumer benefit categories	13
When will this change take place?	14
Implementation date	14
Date decision required by	14
Implementation approach	14
Proposer's justification for governance route	14
Interactions	15
Acronyms, key terms and reference material	16
Reference material	16
Annexes	17

What is the issue?

This proposal is based on an alternative proposal (WAGCM2) to GC0151 'Grid Code Compliance with Fault Ride Through Requirements'. It was proposed during the GC0151 workgroup by Drax Power Ltd and aimed to clarify the technical requirements for fault ride through capability set out in the Grid Code to improve consistency, accuracy and understanding and to help prevent non-compliance with the Grid Code.

Ofgem in their decision letter on GC0151 noted the views of various stakeholders and Panel members that while WAGCM2 had merit it had been insufficiently scrutinised as part of the urgent development process undertaken for GC0151. Following the implementation of GC0151 the ESO agreed to raise a modification embodying the GC0151 WAGCM2 proposals which the ESO had also broadly supported.

This modification therefore proposes minor changes and improvements to the existing Grid Code Fault Ride Through (FRT) requirements as a minimum but not limited to the following:

- To clarify instances where User plant is permitted to trip where required in order to clear the fault from the transmission system.
- To amend requirements for generating maximum reactive current during faults which may be unachievable for many Generators.
- To amend post fault active power requirements to reflect that low load Generators may have greater oscillations than the requirements currently allow for.
- To provide requirements for overvoltage events following a fault.

Why change?

To enable Generators to better assess their compliance to FRT requirements, which will enhance system security during fault conditions, and to avoid unnecessary compliance proceedings following an incident where a Generator may have tripped for allowable reasons by achieving greater clarity for all parties.

What is the proposer's solution?

The sections of the code to which changes are proposed are CC.6.3.15 and ECC.6.3.15 which together form the FRT technical conditions for all applicable plant.

There are several other issues within the existing legal text in the Grid Code relating to FRT. These issues highlight that there are technical compliance issues due to the current drafting of the Grid Code and other issues dealing with the understanding of the current legal text. The following sections explain the various issues and proposed solutions and the full proposed legal text can be found in Annex 1.

Clarification of Fault Ride Through Requirement

The way CC.6.3.15(a)(i) is written deals both with plant capability and actions to be taken during a fault, however, it does not clearly distinguish between either leading to confusion.

It is suggested that the current CC.6.3.15(a)(i) is split into two sections, one dealing with the required capability CC.6.3.15(a)(i)(a) and a second section CC.6.3.15(a)(i)(b) dealing with actions to be taken during a fault.

Plant Capabilities

The new section CC.6.3.15(a)(i)(a) will only deal with plant capabilities by clarifying that the plant has to be capable of riding through the worst fault that the network could impose which is a 3-phase short circuit at the connection point which lasts for up to 140ms as shown in figure 1 below. To achieve this, the words “be design to” will be added to section CC.6.3.15(a)(i)(a) as can be seen in the legal text in appendix 1.

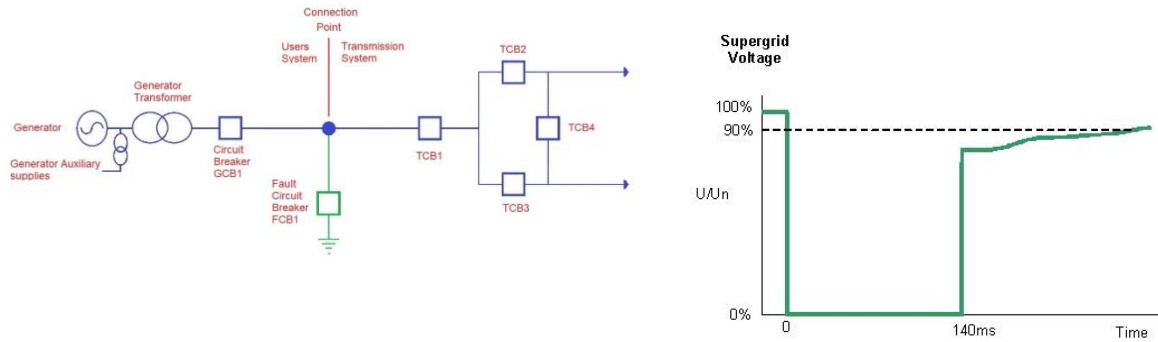

Figure 1 showing theoretical worst case fault which plant must be capable of riding through

Operating Requirements During a Fault

The new section CC.6.3.15(a)(i)(b) will specify the actions to be taken if a fault occurs by requiring that plants ride through faults in the transmission system which can be cleared by the transmission system circuit breaker as shown in figure 2 below and by adding the following text as the introduction to the section

- (b) Each **Generating Unit, DC Converter, or Power Park Module** and any constituent **Power Park Unit** thereof and **OTSDUW Plant and Apparatus** shall remain transiently stable and connected to the **System** without tripping of any **Generating Unit, DC Converter or Power Park Module** and / or any constituent **Power Park Unit, OTSDUW Plant and Apparatus**, and for **Plant and Apparatus** installed on or after 1 December 2017, reactive compensation equipment, for any balanced and unbalanced fault where subjected to a voltage dip at either the **Onshore Grid Entry Point or Interface Point** as applicable where the voltage remains either on or within the envelope shown in figure CC.6.3.15(a)(i)(a) except where:

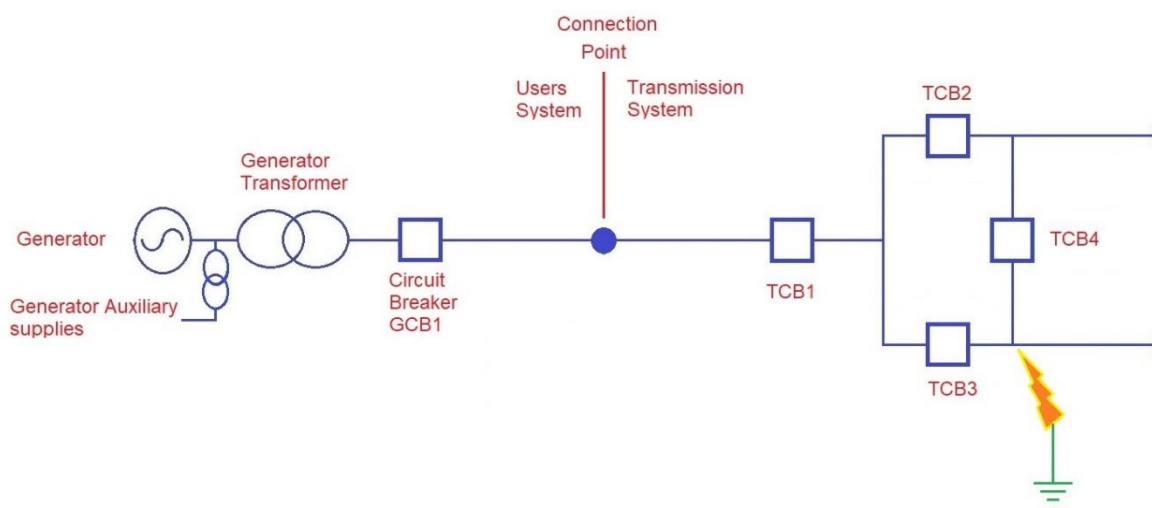

Figure 2 showing a fault which can be cleared by transmission system breakers TCB3 & 4

Whilst the introduction to this section deals with plants riding through faults as it is currently drafted in the Grid Code, it is not clear what is supposed to happen where the plant's circuit breaker has to open to clear the fault. There are concerns that the current text could be interpreted that the plant shall remain connected feeding the fault for 140ms which could lead to dangerous situations. It is clear this is not the intent, and that plant should trip during these circumstances. It is proposed that the following subclauses are added to clarify each situation where tripping is permitted.

Firstly if the fault is on the Generator's equipment then the Generator shall be required to trip to clear the fault from the transmission system as detailed in the proposed new section CC.6.3.15(a)(ii)(b)(i) (note that this is already permitted in the ECCs), as follows:-

Power Park Module and any constituent **Power Park Unit** thereof and **OTSDUW Plant and Apparatus** shall trip to clear the fault from the **Transmission System**. The protection schemes and settings should not jeopardise **Fault Ride Through** performance as specified in CC.6.3.15.1

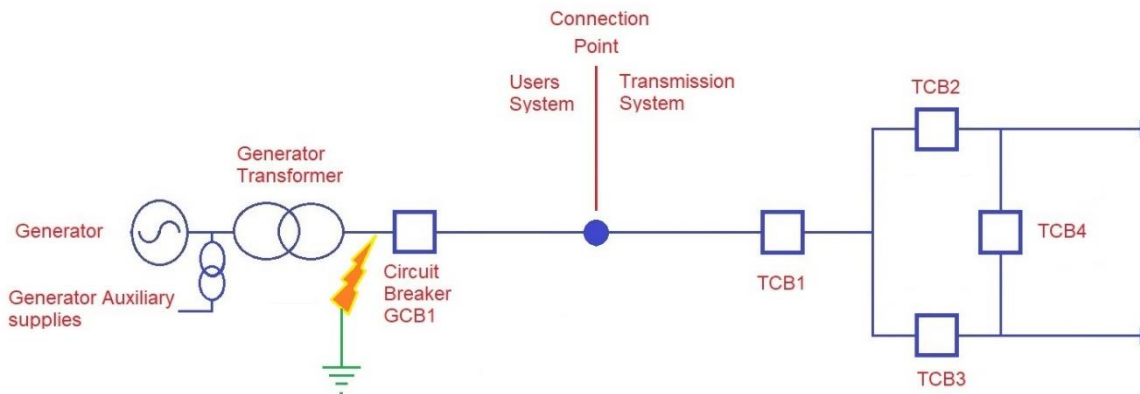

Figure 3 showing a fault which can only be cleared by generator breakers GCB1

Secondly if the location of the fault on the network that means that the fault can only be cleared by operation of both Transmission and the Generator circuit breaker as shown in figure 4, again the Generator will be permitted to trip to clear the fault as detailed in the proposed new section CC.6.3.15(a)(i)(b)(ii) and ECC.6.3.15.8(vi)(i), as follows:-

the location of the fault means it cannot be fully cleared without tripping the of **Generating Unit, DC Converter, or Power Park Module** and any constituent **Power Park Unit** thereof and the **OTSDUW Plant** shall trip as required.

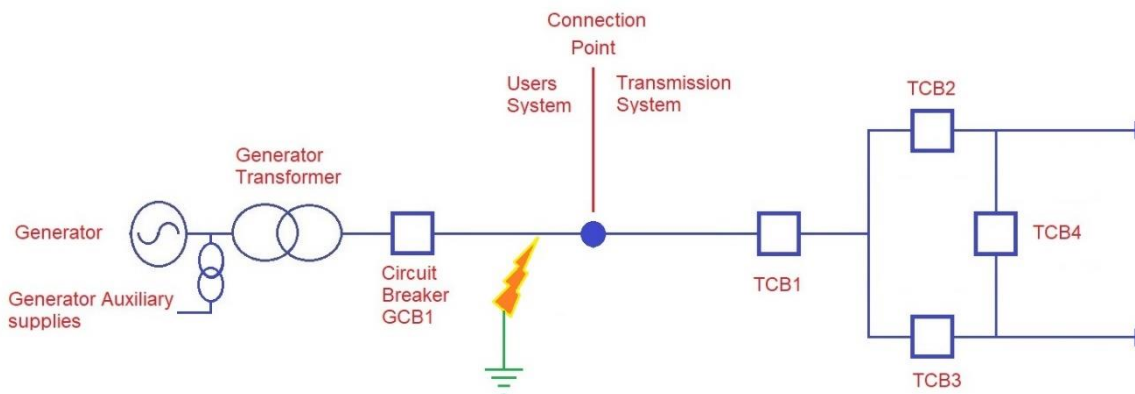

Figure 4 showing a fault which can only be cleared by generator breaker GCB1 & transmission circuit breaker TCB1

Thirdly, if the location of the fault on the network means that the Generator will become islanded by the operation of the transmission circuit breakers as shown in figure 5 then it shall be permitted to trip as detailed in the proposed new sections CC.6.3.15(a)(ii)(b)(iii) and ECC.6.3.15.8(vi)(ii), as follows:-

clearance of the fault results in the **Generating Unit, DC Converter, or Power Park Module or OTSDUW Plant** becoming islanded and disconnected from the **Total System** and not supplying **Customers** (where CC.6.3.7(c)(i) applies), then the **Generating Unit, DC Converter, or OTSDUW Plants** shall be permitted to trip as required.

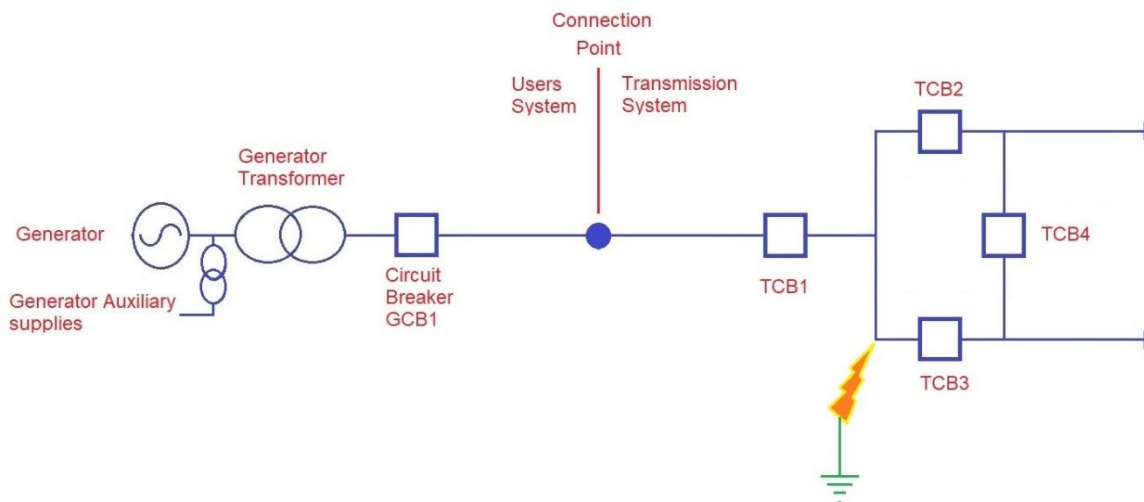

Figure 5 showing a fault which can be cleared by transmission breakers TCB1,2&3, however this results in the Generator being islanded from the main transmission system and needs to come off

Also, if there are inter-trip arrangements with the TO or ESO in relation to protection schemes to prevent cascade overloading, etc then plants shall be required to trip as per these arrangements as detailed in the proposed new section CC.6.3.15(a)(i)(b)(iv & v) and ECC.6.3.15.8(iii & iv), as follows:-

the **Generating Unit, DC Converter, or Power Park Module** and any constituent **Power Park Unit** thereof and **OTSDUW Plant** is part of combined protection scheme with the **Transmission Operator**, then the **Generating Unit, DC Converter, or Power Park Module** and any constituent **Power Park Unit** thereof and **OTSDUW Plants** shall be permitted to trip as required.

the **Generating Unit, DC Converter, or Power Park Module** and any constituent **Power Park Unit** thereof and **OTSDUW Plant** is part of and intertrip scheme which is switched into service and triggered, then the **Generating Unit, DC Converter, or Power Park Module** and any constituent **Power Park Unit** thereof and **OTSDUW Plants** shall be permitted to trip as required.

There is a final section on Offshore transmission which already exists and has just been moved as it relates to operational actions and is not a capability, this is basically the original text as detailed in section CC.6.3.15(a)(i)(b)(vi) (note there was no original text equivalent to this in the ECCs so it has not been added) as follows:-

in the case of an **Offshore Generating Unit, Offshore DC Converter or Offshore Power Park Module** (including any **Offshore Power Park Unit** thereof) which is connected to an **Offshore Transmission System** which includes a **Transmission DC Converter** as part of that **Offshore Transmission System**, the **Offshore Grid Entry Point** voltage may not indicate the presence of a fault on the **Onshore Transmission System**. The fault will affect the level of **Active Power** that can be transferred to the **Onshore Transmission System** and therefore subject the **Offshore Generating Unit, Offshore DC Converter or Offshore Power Park Module** (including any **Offshore Power Park Unit** thereof) to a load rejection

Fault Current Injection

The area of the current legal text which technically creates the biggest problem in relation to compliance are in sections CC.6.3.15 (a)(ii) and ECC.6.3.15.9.2.1(a)(i) which currently state "for which the voltage at the Grid Entry Point (or Interface Point in the case of OTSDUW Plant and Apparatus) is outside the limits specified in CC.6.1.4, each Generating Unit or Power Park Module or OTSDUW Plant and Apparatus shall generate maximum reactive current". If this requirement is drawn out on the figure 6 below where the current and voltage must always either be within the green shaded area or on the red line.

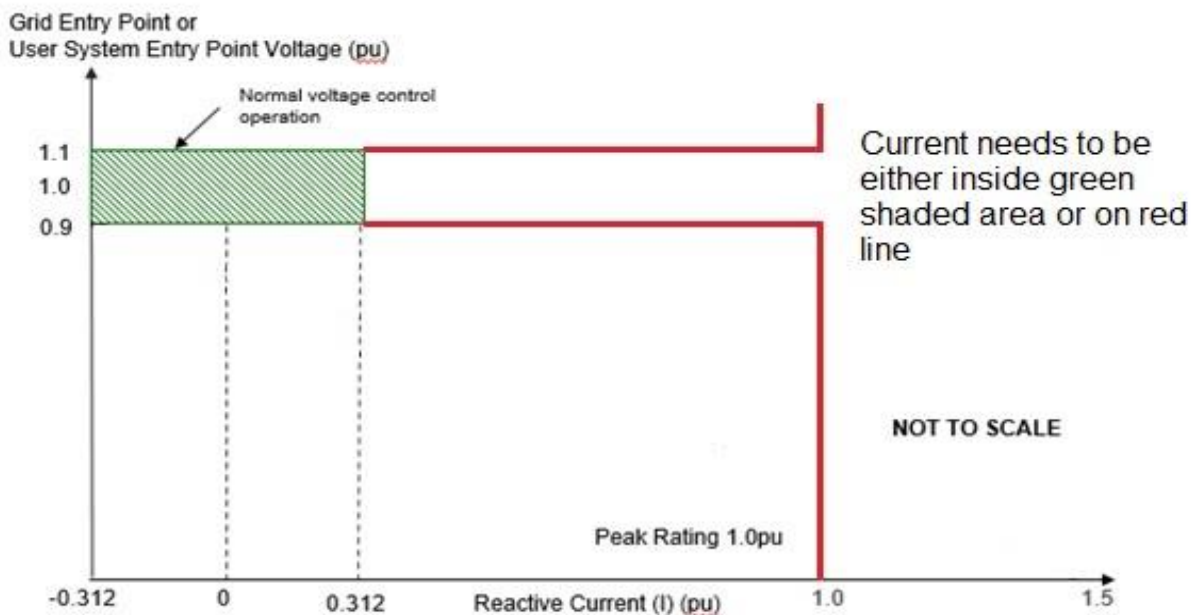

Figure 6 showing an interpretation of the existing legal text requiring the current to either be in the green box or on the red line

The reason this creates compliance issues is: as drafted, very few plants (if any) actually do this and it has presumably drifted in as a drafting oversight relating to PPM requirements. This issue has previously been identified in the workgroup GC0111 on Fast Fault Current injection and in the GC0137 VSM workgroup and has been fixed for new PPMs, however currently all synchronous Generator and older PPM will technically be non-compliant with this FRT requirement as drafted. This issue was dealt with in GC0111 by adding a new Figure ECC.6.3.16(a), however this is more onerous than is required for GB Users so the graph shown in figure 7 is proposed with text changes as follows:-

- (iv) During the period of the fault as detailed in CC.6.3.15.1 (a) (i) for which the voltage at the **Grid Entry Point** (or **Interface Point** in the case of **OTSDUW Plant and Apparatus**) is outside the limits specified in CC.6.1.4, each **Generating Unit** or **Power Park Module** or **OTSDUW Plant and Apparatus** shall inject a reactive current above the heavy black line shown in Figure CC.6.3.15(b) without exceeding the transient rating limit of the **Generating Unit, OTSDUW Plant and Apparatus** or **Power Park Module** and / or any constituent **Power Park Unit** or reactive compensation equipment.

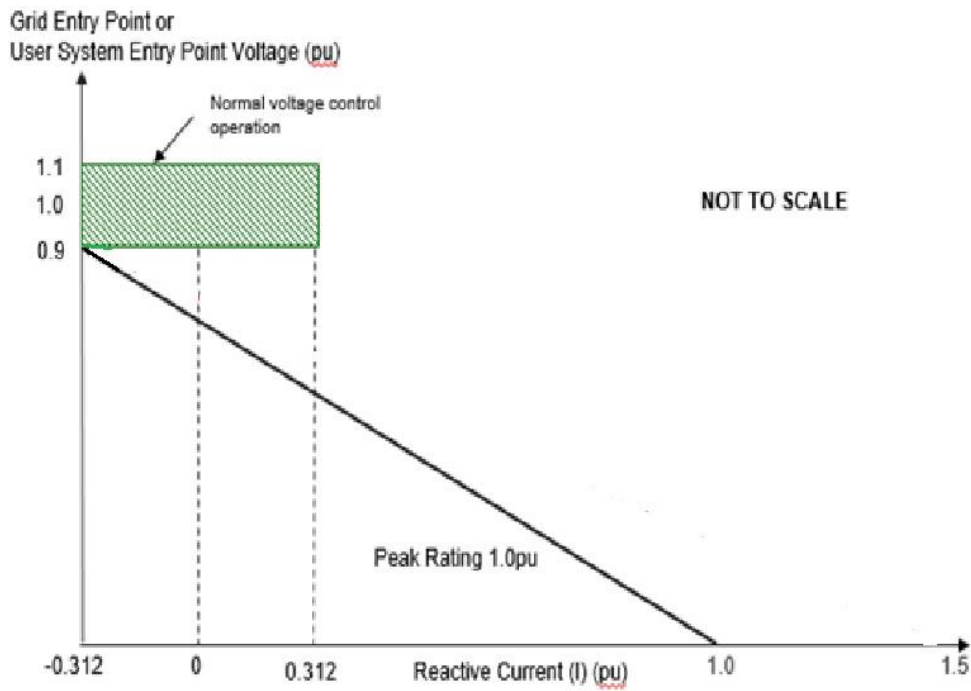

Figure 7 showing the proposed reactive current injection requirements, requiring the current to always remain above the black line

Active Power Requirements

The final area of concern is the minimum active Power requirements after the fault has cleared because within CC.6.3.15.1 a) ii) it states:

(or within 0.5 seconds of restoration of the voltage at the **User System Entry Point** to 90% of nominal or greater if **Embedded**), Active Power output or in the case of OTSDUW Plant and Apparatus, Active Power transfer capability, shall be restored to at least 90% of the level available immediately before the fault. Once the Active Power output, or in the case of OTSDUW Plant and Apparatus, Active Power transfer capability, has been restored to the required level, Active Power oscillations shall be acceptable provided that:

- the total Active Energy delivered during the period of the oscillations is at least that which would have been delivered if the Active Power was constant
- the oscillations are adequately damped

Whilst this works in principle at higher loads, it does create an issue at lower loads if you consider a real event for a unit operating as a synchronous condenser in figure 8.

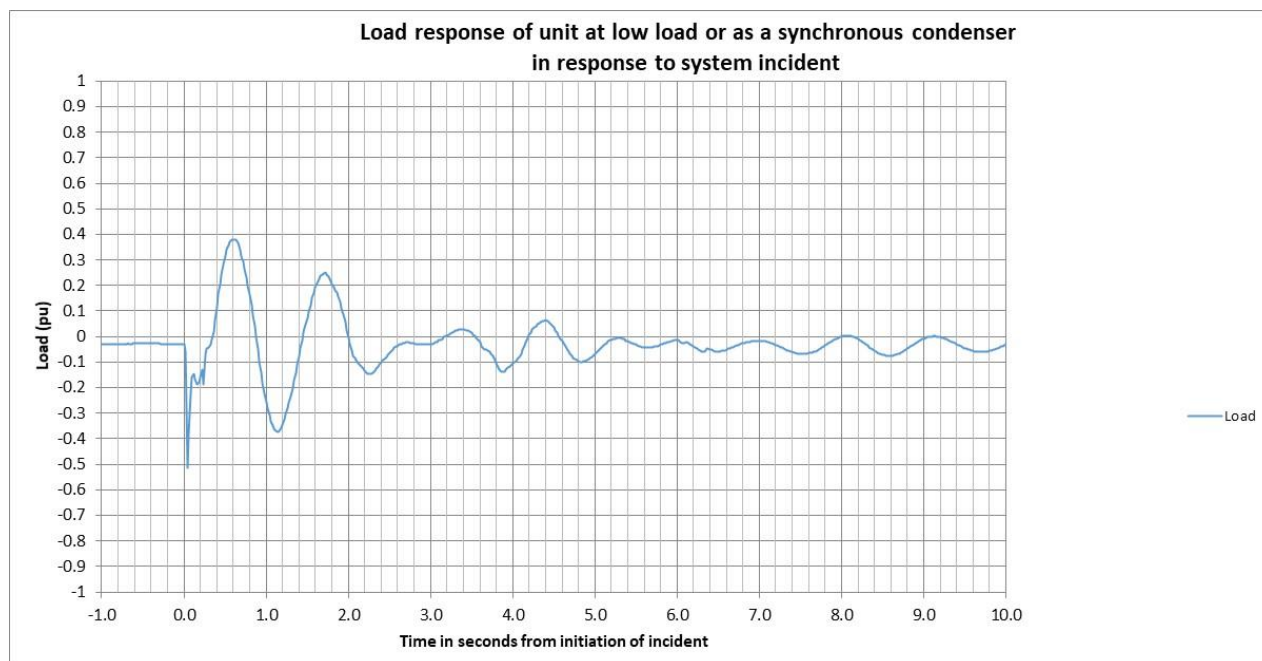

Figure 8 showing a typical active power response of a unit at low load to a fault

If you look at the initial load which is 0.02 pu then 90% of this small number you get a very small number, it is also difficult to see how a sensible compliance assessment can be carried out at these levels and it is hence suggested that under these circumstances the tolerance should be changed.

Voltage Protection Settings

The Original proposal for GC0151 included looking at the relationship between voltage and FRT criteria however no text was included in either the Original or WAGCM2 as it was deemed too difficult for the urgent time scale.

Whilst the Grid Code defines in detail the FRT requirements for voltage dips, it is silent on the need for Users or Network Operators to remain connected for transient over-voltages, particularly those that are expected to occur after the clearance of a fault. Therefore it is possible, for example, that currently a Generator or Interconnector may successfully ride through a voltage dip, but trip when the fault is cleared as the resulting over-voltage transient is sufficiently high or sustained that it could trigger over-voltage protection that would ordinarily be expected to be fitted by the User (or Network Operator) to protect their equipment.

It is also possible a User site or Network Operator asset could ride through a low voltage fault but incorrectly configured protection settings result in the User site or Network Operator asset(s) tripping or de-loading.

To provide further clarity to Users and Network Operators, it is proposed that wording along the following lines would be added to Section CC.6.3.15.3 and ECC.6.3.15.10 ('Other Fault Ride Through Requirements'):

- Users and Network Operators shall ensure voltage sensitive relays installed to protect the User's plant and / or apparatus or Network Operator's asset are configured such that they will not prevent correct operation of the Fault-Ride-Through capability of the User's equipment (or Network Operator's assets) against the relevant Voltage-Time curves. For example,
 - o Over-voltage protection shall be configured to be insensitive to transient overvoltages of at least 1.20pu for at least 0.5 seconds.
 - o Under-voltage protection shall be configured to be insensitive for transient undervoltages of below 0.8pu for at least 3 seconds

Draft legal text

The draft legal text created as part of WAGCM2 "GC0151 WAGCM2 Alternative Proposal Legal Text" is attached in annex 1 as a proposed starting point.

What is the impact of this change?

Proposer's assessment against Grid Code Objectives

Relevant Objective	Identified impact
(a) To permit the development, maintenance and operation of an efficient, coordinated and economical system for the transmission of electricity	Positive By improving Generator confidence in their ability to comply with FRT requirements and lessening the likelihood of compliance proceedings including following an incident where

	a Generator has tripped for allowable reasons.
(b) Facilitating effective competition in the generation and supply of electricity (and without limiting the foregoing, to facilitate the national electricity transmission system being made available to persons authorised to supply or generate electricity on terms which neither prevent nor restrict competition in the supply or generation of electricity);	Neutral [Please provide your rationale]
(c) Subject to sub-paragraphs (i) and (ii), to promote the security and efficiency of the electricity generation, transmission and distribution systems in the national electricity transmission system operator area taken as a whole;	Positive By providing clearer guidance on expected behaviour following a fault, Generators are able to prepare more effectively and be more resilient as a result so improving system security.
(d) To efficiently discharge the obligations imposed upon the licensee by this license and to comply with the Electricity Regulation and any relevant legally binding decisions of the European Commission and/or the Agency; and	Neutral [Please provide your rationale]
(e) To promote efficiency in the implementation and administration of the Grid Code arrangements	Positive By improving clarity in FRT requirements this will help to improve efficiency.

Proposer's assessment of the impact of the modification on the stakeholder / consumer benefit categories

Stakeholder / consumer benefit categories	Identified impact
Improved safety and reliability of the system	Positive This change should improve compliance to FRT as the obligations will be clearer meaning a more stable system during fault conditions.
Lower bills than would otherwise be the case	Positive By reducing non-conformities this should reduce the need to constrain generators following a fault.
Benefits for society as a whole	Positive

	Reducing tripping will provide a more stable network ensuring security of supply.
Reduced environmental damage	Neutral No Impact
Improved quality of service	Positive Providing clearer guidance to new and existing connections on their obligations.

When will this change take place?

Implementation date

10 Days after approval by authority

Date decision required by

The decision is required from the Authority as soon as reasonably practicable

Implementation approach

The implementation approach will depend on the level of change required by industry following clarifications provided by the workgroup.

Proposer's justification for governance route

Governance route: Standard Governance modification with assessment by a Workgroup

These proposals were accepted by Ofgem to have merit – but in rejecting their original submission for GC0151 WAGCM2, Ofgem noted the feedback from stakeholders that further scrutiny in a non-urgent workgroup was required.

Interactions

- | | | | |
|----------------------------------------------------|--------------------------------------------------------------|-------------------------------------------------|--------------------------------|
| <input type="checkbox"/> CUSC | <input type="checkbox"/> BSC | <input type="checkbox"/> STC | <input type="checkbox"/> SQSS |
| <input type="checkbox"/> European
Network Codes | <input type="checkbox"/> EBR Article 18
T&Cs ¹ | <input type="checkbox"/> Other
modifications | <input type="checkbox"/> Other |

¹ If your modification amends any of the clauses mapped out in Annex GR.B of the Governance Rules section of the Grid Code, it will change the Terms & Conditions relating to Balancing Service Providers. The modification will need to follow the process set out in Article 18 of the Electricity Balancing Regulation (EBR – EU Regulation 2017/2195). All Grid Code modifications must be consulted on for 1 month in the Code Administrator Consultation phase, unless they are Urgent modifications which have no impact on EBR Article 18 T&Cs. N.B. This will also satisfy the requirements of the NCER process.

Acronyms, key terms and reference material

Acronym / key term	Meaning
BSC	Balancing and Settlement Code
CUSC	Connection and Use of System Code
EBR	Electricity Balancing Regulation
GC	Grid Code
STC	System Operator Transmission Owner Code
SQSS	Security and Quality of Supply Standards
T&Cs	Terms and Conditions
FRT	Fault Ride Through

Reference material

- [GC0151](#)
- [OFGEM Decision](#)

Annexes

Annex	Information
Annex 1	Draft legal text