

# The potential operability benefits of Virtual Synchronous Machines and related technologies

## A System Operability Framework document

April 2020



# Executive Summary

We at National Grid ESO are always looking at ways to enable new technologies to connect to the network in the most safe, secure and efficient manner. This report discusses how new technologies can support system stability by adopting Virtual Synchronous Machine (VSM) technologies and associated control approaches which will enable transition to a zero carbon system.

## Background

As we move to a low carbon electricity system, more of our power is coming from non-synchronous based renewable sources. At the same time, transmission demand seen by the ESO is decreasing as more embedded generation is connected at distribution level. This means the amount of synchronous generation running at any time is reducing and without system operator intervention, it is becoming challenging to maintain system stability.

Synchronous machines provide stability support to the system. They do this by providing:

- Inertia – which helps to control and stabilise system frequency
- Short circuit level – which helps to control and stabilise system voltage and maintain high performance of power system protection
- Ability to limit vector shift and Rate of Change of Frequency (RoCoF)

Non-synchronous generation is increasing and does not traditionally provide this support so the inherent stability of the power system is declining.

Figure 1 illustrates future non-synchronous growth based on the Future Energy Scenarios. Traditionally non-synchronous plant uses an approach called the Phase-locked Loop (PLL) approach which may lead to instability driving additional system requirements in the future. This conventional control approach for non-synchronous technologies relies on measurements of the network followed by a delay for processing before

an appropriate response is delivered. This approach is robust whilst the network is in a steady state. However when the network is disturbed, this approach is limited in its ability to “track” the voltage and frequency. The weaker the system is, the harder it becomes to respond to the disturbance in a predictable way. We discussed PLL risk in detail in our SOF 2017 report on “[Performance of Phase-locked Loop based converters](#)”)

In this report we explore VSM which is an alternative approach to PLL for non-synchronous generation which provides some of the benefits traditionally provided by synchronous machines.

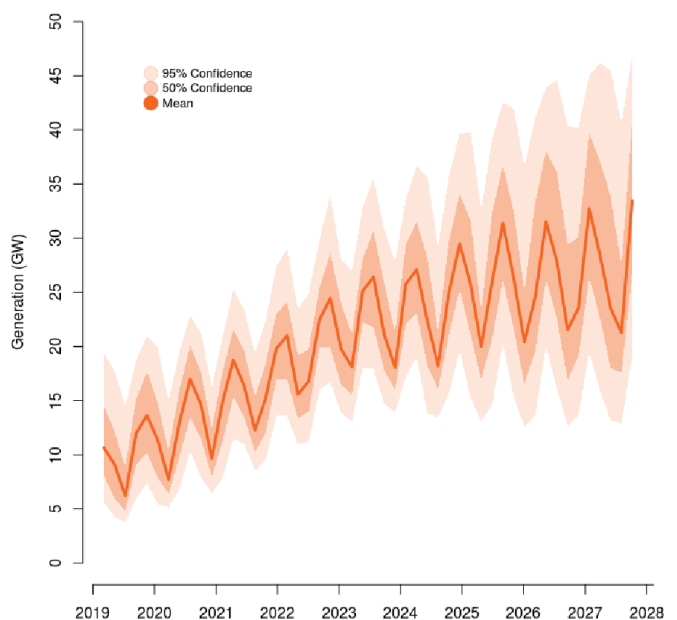

Figure 1: Growth in transmission connected non-synchronous generation output

## Virtual Synchronous Machines

The generation in the grid has shifted and will continue to shift from the large synchronous generators to renewable sources which pass through the control of power electronics when injecting power onto the grid. PLLs have been used as the main tool to synchronise power electronic sources to the grid for many years. They have proven to be highly effective. However, as the synchronous machine generation profile declines the grid will lose valuable inertia which is used to sustain stable operation in the wake of grid disturbances such as faults. The grid will become less stable, as increased penetration of renewable generation dissipates inertia. Virtual synchronous machines have become a solution to solve this issue, allowing for mass penetration of renewable energy.

A virtual synchronous machine is one type of grid forming converter which maintains the voltage and frequency of the grid. It is comprised of a converter-based generator with a control system which mimics some qualities of a synchronous generator. It is an approach which can be potentially deployed across a range of technologies, such as Wind (doubly-fed induction generator and fully converted generator), Solar PV, Battery, and HVDC interconnectors. Virtual Synchronous Machine control designs have been developed by a range of manufacturers.

The conventional PLL is designed to adapt its frequency and phase to those of the surrounding grid. It relies on measurement signals which are expected to be at least 1 cycle long (up to 20ms). Due the measurement delays, the response from a PLL based converter is not instantaneous like a synchronous machine (~5ms). A instantaneous response from a synchronous machine in terms of reactive power and/or inertia contributes to system stability.

The virtual synchronous machine (VSM) concept allows a converter to act like a voltage source like a synchronous machine. The voltage source behaviour is a critical concept for a converter to respond instantaneously to system changes. Therefore, when the disturbance occurs, VSM can supply fault currents and also contribute the system inertia.

## How VSM provides stability support

- VSM and related technologies could improve:
  - Inertia
  - Short circuit level
  - Voltage stability
  - Retained voltage & Fault ride through
- These technologies are not quite the same as synchronous machines but come with similar behavior, though with notable differences
- VSM and related solutions have a “self-righting” benefit

The principle of a VSM control is to allow the VSM to behave as a voltage source behind an impedance. A simple control structure is shown in Figure 2.

Figure 3 shows current waveform due to the VSM control. The key characteristics of VSM are;

1. The VSM produces a 50Hz oscillating voltage waveform at an angle initially delivered by synchronising the converter to the network.
2. During a disturbance the VSM is allowed to freely exchange current with the system as dictated by the physics of a voltage source behind an impedance responding either to a rate of change of voltage angle (frequency) or a voltage magnitude change at the connection point. This “holding” of the internal angle of the oscillator has an effect of resisting the change occurring on the system, supplying inertia and damping the extent of the voltage change.

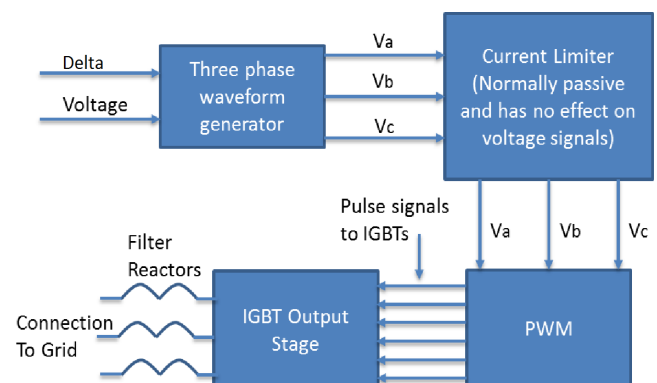

Figure 2: Control structure of VSM (See Abbreviation section)

3. The inertia is a programmable value, sustaining the power supplied to limit the internal angle change of the VSM oscillator. The value of this inertia would need to be defined based on the size of the energy store available and the timeframes across which it is supplied. The current supplied to a voltage disturbance is similarly limited by the converter's capability to support a voltage dip and its duration, followed by its subsequent recovery period.
4. During any disturbance, rather than blocking the current supplied or losing "tracking" with the current supplied, the VSM can "clip" its current supplied, such that the converter can operate across its rating whilst supplying the maximum current possible at the time of the fault. The more VSM connected, and the further away from any disturbance they are, the more limited any "clipping" is.

Figure 4 gives the overall effect of VSM with different time constant if deployed. The time constant is a parameter the manufacture can choose. Normally a bigger inertia will have a bigger cost as it requires more storage/converter rating.

- In 2020, if there is no VSM deployed, 50% of the year is spent at 165GVA.s of national inertia. An improvement of 20GVA.s is achieved with the deployment of VSM on all new non-synchronous generation with an inertia time constant of 2s. A further improvement of 60GVA.s is achieved if the VSM increases its inertia time constant to 5s.

- The effect of the deployment of the VSM increases in 2025 as more of our power is coming from renewable sources, and the amount of synchronous generation running at any time is reduced. The national inertia for 50% of the year is then reduced from 165GVA.s in 2020 to 115GVA.s in 2025 if no VSM is deployed. The inertia increases from 115GVA.s to 175GVA.s by deploying the VSM with inertia time constant of 2s. The inertia further increases to 270GVA.s by deploying the VSM with inertia time constant of 5s.
- The effect of the deployment of the VSM further increases in 2030 as the share of renewables in the country's electricity generation rises. An improvement of 90GVA.s is achieved with the deployment of VSM with an inertia time constant of 2s comparing without VSM. A further improvement of 140GVA.s is achieved if the VSM increased its inertia time constant to 5s. The figure finally chosen will be dependent on the cost of deployment.

## Other technologies providing stability support

In addition to VSM and related technologies, a range of other approaches for supporting stability exist. This includes, but is not limited to;

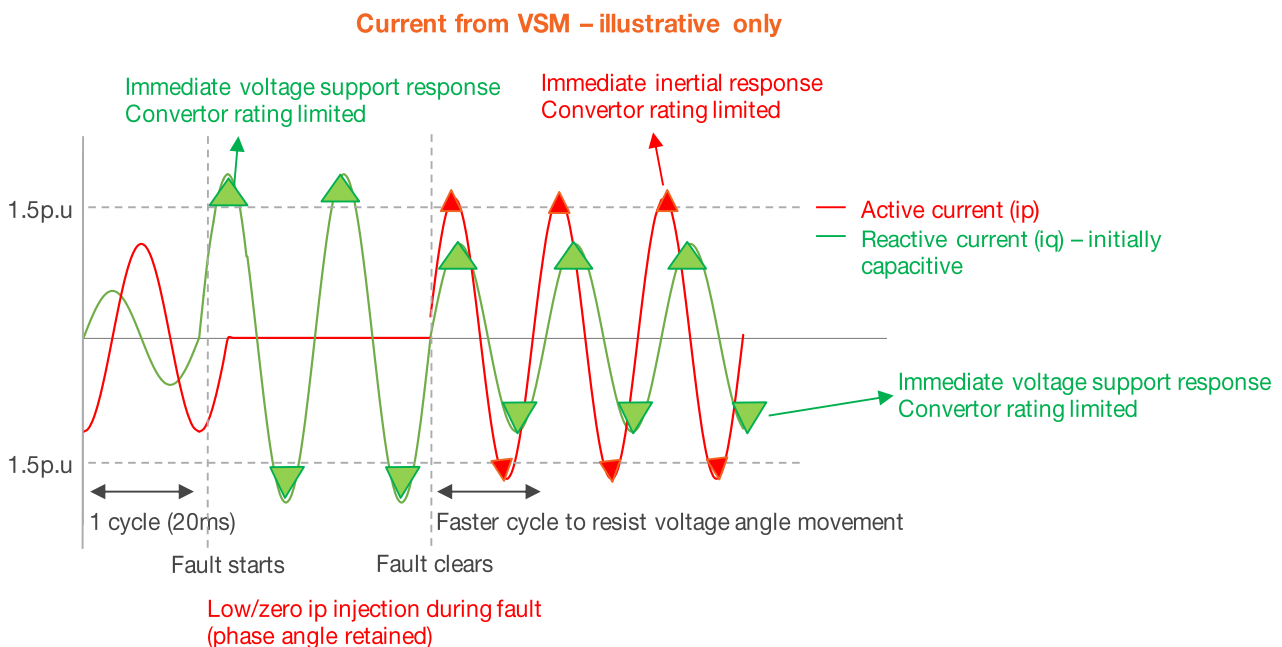

Figure 3: Illustration of current from a VSM control

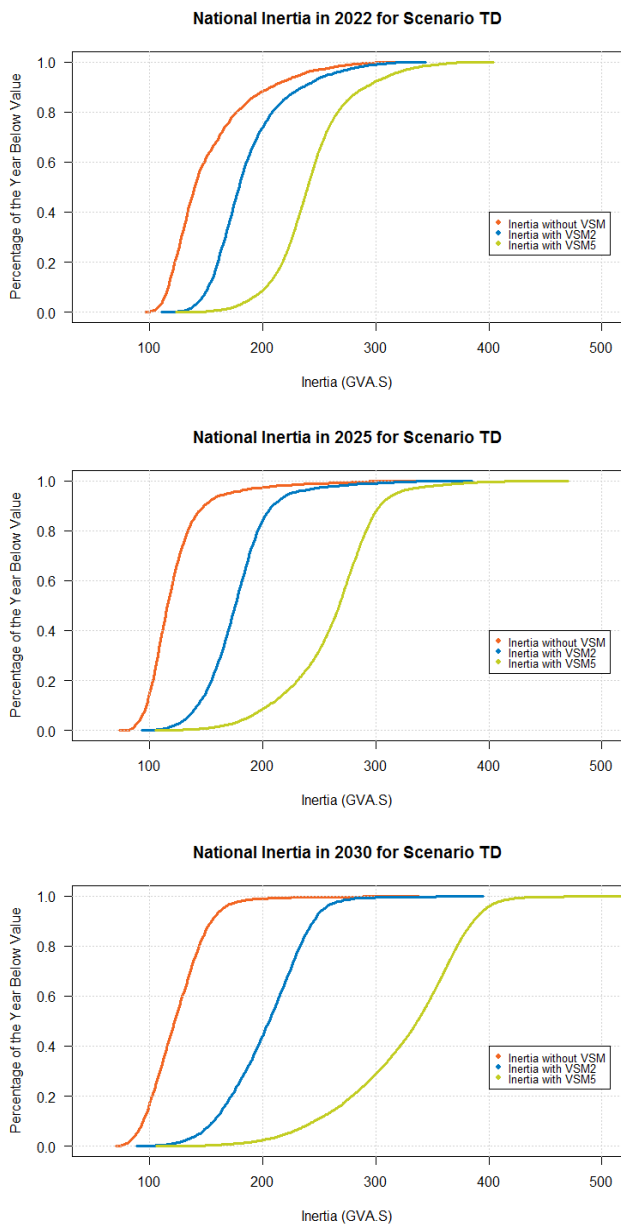

Figure 4: Example of effect of VSM in National Inertia

- Solutions such as the introduction of synchronous compensators or modifications to the network which improve its stability.
- Synchronous generation operating in a “de-clutched” mode such that it may operate as a synchronous compensator when not operating in the energy market.
- Synchronous generation operating at lower output levels whilst providing stability support.
- Fly-wheels, air compressor, hybrid synchronous and converter based designs.

Figure 5 illustrates one potential feature of the future system energy balance which may be of consideration for this range of technologies. It shows the GVA of existing and future new synchronous capacity not running for the year over the next ten years. This would represent existing generation no longer

operating in the energy market, together with other generators operating on the basis of two-shifting or other non-baseload running patterns. Across these periods, opportunities for stability focussed operation of existing or other assets may exist for existing parties to consider.

There is no such thing as a “magic bullet” for stability or other operability solutions. Rather there are a range of operability tools within which stability supporting converter solutions such as VSM together with a range of other technologies (for example Synchronous Compensation) have the potential fit. The overall combination of these and other market actions must be considered in totality to achieve efficient and economic overall solutions to satisfy our stability requirements.

## Next steps

- The VSM expert working group has explored VSM based technologies supporting system stability, and examined the need for Grid Code changes
- Stability Pathfinder Phase Two in Scotland will explore implementation of range of technologies that can meet our stability needs

National Grid ESO has established a Grid Code Expert Workgroup to examine the principles of grid supporting technologies since April 2018. The workgroup has discussed a potential VSM specification to be incorporated in the Grid Code.

In relation to this working group and in conjunction with

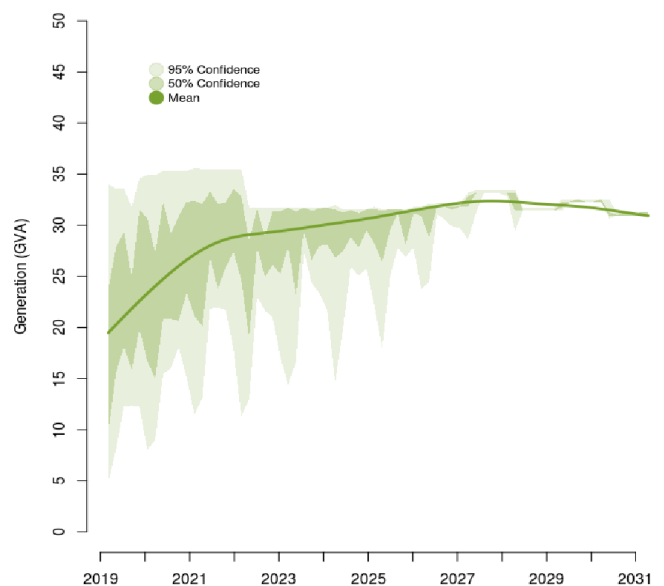

Figure 5: Synchronous capacity available for additional stability support scenario Two Degrees

users, National Grid ESO has variously actively explored work on:

1. The network benefits of VSM solutions
2. The illustrative prototyping of a lab scale VSM control. Two NIA projects are carried out. One is Virtual Synchronous Machine (VSM) Demonstrator [1]. The other is Hybrid Grid Forming Converter [2].
3. The practicality of VSM principles as incorporated within the design of Power Park modules and/or their connection infrastructure
4. The demonstration of a grid scale converter performance of a battery against a range of practical tests and benchmark modelling
5. Further work enhancing understanding and modelling of new forms of network instability risk

Taking this work into account, we are considering a minimum technical specification to be considered for future VSM based stability solutions.

We have worked with other utilities and organisations in exploring and developing our understanding of the requirements of stability support and examining the technologies to support stability. Much of this work has been world leading, with further innovation required to progress the deployment of solutions.

We are currently exploring under our stability pathfinder phase two, the most appropriate frameworks and options for the procurement of a range of stability support capabilities. We have defined a minimum technical specification, which is designed to encourage the broadest range of provision across all available technologies, provided these options are sufficiently mature to be delivered to the timeframes outlined.

Across the range of technologies available, there remain a number of practical questions informing their deployment, which we will continue to learn through our planned pathfinder and other work:

1. How best to deploy technical codes to enable solutions to be delivered
2. What models, and to what level of detail are required to validate performance- what range of practical testing should be conducted to support deployment of these new technologies to new criteria
3. How best to structure and integrate market solutions with Network Owner solutions

4. How the insights gathered from the range of solutions available inform enduring market arrangements

National Grid ESO will continue to engage with the industry to explore and enable a range of activities to deliver an appropriate range of approaches for delivering future stability support to the network.

## Conclusions

As we have discussed in previous SOF reports the trend of declining synchronous generation and increasing non-synchronous generation presents an increasing challenge for operability as we move towards our ambition of zero carbon operation in 2025. VSM technologies are a new potential solution to these challenges to complement the existing options. This report illustrates that as well as opportunity there is also complexity to the delivery and integration of a range of new solutions.

To mitigate these challenges and set us on the path to our 2025 ambition:

- We continue our work on our Stability pathfinder project and set out what products and services are required to maintain future stability. Stability pathfinder provides long-term contracts to help develop this new service for both commercial and network owner solutions. In addition to the Stability Pathfinder approach we are also exploring a close to real time market for stability support.
- We will continue to support the development of the widest possible range of solutions for stability in the pathfinders and more broadly. The aim of the Stability pathfinder is to compare network owner solutions and commercial solutions for long term stability needs. All technologies will be able participate including VSM. The cost benefit analysis will determine which solutions are best value for consumers.
- We will explore through technical codes and further innovation work the best way to facilitate the deployment of the wide range of solutions that maintain a secure and economically efficient future network. A Grid code working group has initiated this year to look at including a VSM/Grid Forming specification into the Grid Code. The working group's proposal is to make this a non-mandatory specification and create a route to any future stability market. The specification under consideration aligns with stability pathfinder.

## Abbreviations

DFIG	Doubly-Fed Induction Generator
IGBT	Insulated-Gate Bipolar Transistor
NIA	Network Innovation Allowance
PLL	Phase-locked Loop
PWM	Pulse Width Modulation
RoCoF	Rate of Change of Frequency
SOF	System Operability Framework
VSM	Virtual Synchronous Machines

## Reference

[1][https://www.smarternetworks.org/project/nia\\_ngso0004/documents](https://www.smarternetworks.org/project/nia_ngso0004/documents)

[2][https://www.smarternetworks.org/project/nia\\_ngso0019](https://www.smarternetworks.org/project/nia_ngso0019)

## Continuing the conversation

Join our mailing list to receive email updates for SOF or any of our Future of Energy documents:  
[subscribers.nationalgrid.co.uk/h/d/7E1C22C6A81C87FE](https://subscribers.nationalgrid.co.uk/h/d/7E1C22C6A81C87FE)

Email us with your views on the System Operability Framework:  
[sof@nationalgrideso.com](mailto:sof@nationalgrideso.com)

Access our current and past SOF documents and data:  
[nationalgrideso.com/insights/system-operability-framework-sof](https://nationalgrideso.com/insights/system-operability-framework-sof)

## Disclaimer

The information contained within the *System Operability Framework* document ('the Document') is disclosed voluntarily and without charge. The Document replaces the System Operation section of the *Electricity Ten Year Statement (ETYS)* and is published in accordance with the relevant Licence conditions.

National Grid would wish to emphasise that the information must be considered as illustrative only and no warranty can be or is made as to the accuracy and completeness of the information contained within this Document. Neither National Grid Electricity Transmission, National Grid Gas nor the other companies within the National Grid group, nor the directors, nor the employees of any such company shall be under any liability for any error or

misstatement or opinion on which the recipient of this Document relies or seeks to rely other than fraudulent misstatement or fraudulent misrepresentation and does not accept any responsibility for any use which is made of the information or Document which or (to the extent permitted by law) for any damages or losses incurred. Copyright National Grid 2018, all rights reserved. No part of this Document or this site may be reproduced in any material form (including photocopying and restoring in any medium or electronic means and whether or not transiently or incidentally) without the written permission of National Grid except in accordance with the provisions of the Copyright, Designs and Patents Act 1988.