

Stage 06: Final Modification Report	At what stage is this document in the process?
--	--

CMP303 - Improving local circuit charge cost-reflectivity

01	Initial Written Assessment
02	Workgroup Consultation
03	Workgroup Report
04	Code Administrator Consultation
05	Draft Final Modification Report
06	Final Modification Report

Purpose of Modification: This modification seeks to make part of the TNUoS charge more cost-reflective through removal of additional costs from local circuit expansion factors that are incurred beyond the connected, or to-be-connected, generation developers' need.

This Final Modification Report has been prepared in accordance with the terms of the CUSC. An electronic version of this document and all other CMP303 related documentation can be found on the National Grid ESO website via the following link:
<https://www.nationalgrideso.com/codes/connection-and-use-system-code-cusc/modifications/improving-local-circuit-charge-cost>



At the CUSC Panel meeting on 25 October 2019, the Panel Members by majority recommended that the Original and WACM3 better facilitated the CUSC objectives than the baseline.

 On 11 June 2019, the Authority sent- back CMP303. The Authority determined that an opinion could not be formed based of the Final Modification report submitted on 18 April 2019. The Authority directed that the Final Modification report was revised and resubmitted to take into account the concerns addressed in the decision letter. A copy of the decision letter can be found via the following link:
<https://www.nationalgrideso.com/codes/connection-and-use-system-code-cusc/modifications/cmp303-improving-local-circuit-charge-cost>

At the CUSC Panel meeting on 25 October 2019, the Panel voted on CMP303 against the Applicable CUSC Charging Objectives and by majority recommended that the Original and WACM3 better facilitated the CUSC objectives than the baseline.

The purpose of this document is to assist the Authority in making its determination on whether to implement CMP303.

 **High Impact:** Directly Impacted Generators

	Medium Impact: Some local circuit-connected generation connectees (medium or low – more probably low)
	Low Impact: Other users of the transmission system (generators) who directly or indirectly pay TNUoS charge (very low)
	The Workgroup concludes: All Workgroup Members concluded that the Original Proposal, WACMs 1,2,3,8 and 9 better facilitated the CUSC objectives when compared to Baseline.

Contents		 Any questions?
1	About this document	3
2	Original Proposal	5
3	Proposer's solution	6
4	Workgroup Discussions	7
5	Workgroup Consultation responses	28
6	Workgroup Vote	39
7	CMP303: Relevant Objectives	53
8	Implementation	54
9	First Code Administrator Consultation Responses – Summary	54
10	Second Code Administrator Consultation Response Summary	80
11	CUSC Panel Vote	83
12	Legal Text	96
13	Impacts	96
14	Annex 1: CMP303 Terms of Reference	97
15	Annex 2: CMP303 Attendance Register	98
16	Annex 3: Workgroup Consultation Responses	100
17	Annex 4: NGESO Analysis	101
18	Annex 5: Workgroup Member Analysis	102
19	Annex 6: Alternative Request forms	103
20	Annex 7: Legal text for WACMs	104
21	Annex 8: First Code Administrator Consultation Responses	105
22	Annex 9: Xero Energy Position Paper: WACM3	106
23	Annex 10: Xero Energy Position Paper - Wider System	

Contact:
Joseph Henry, Code Administrator

 joseph.henry2@nationalgrideso.com

 07970673220

Proposer:
Paul Mott, EDF Energy

 paul.mott@edfenergy.com

 07752 987992

National Grid ESO Representative:
Harriet Harmon

 harriet.harmon@nationalgrideso.com

 07970458456

Benefits of HVDC – CIGRE	107
24 Annex 11: Further ESO Analysis: WACM Scenarios	108
25 Annex 12: Ofgem Send Back Letter	109
26 Annex 13: Second Code Administrator Consultation Responses	110

Timetable

The Code Administrator recommends the following timetable:

Code Administration Consultation Report issued to the Industry (5WD)	25 September 2019
Draft Final Modification Report presented to Panel	17 October 2019
Modification Panel decision	25 October 2019
Final Modification Report issued to Authority (25 WD)	11 November 2019
Indicative Decision Date	13 December 2019
Decision implemented in CUSC	1 April 2020

1 About this document

This document is the Final Modification Report that contains the discussion of the Workgroup which formed in October 2018 to develop and assess the proposal, the responses to the first Workgroup Consultation which closed on 22 January 2019 and the voting of the Workgroup held on 13 February 2019. The Panel reviewed the Workgroup Report at their CUSC Panel meeting on 22 February 2019 and agreed that the Workgroup had met its Terms of Reference and that the Workgroup could be discharged. A Code Administrator Consultation was held for 20 working days from 26 February 2019. Subsequently, the CUSC Panel voted on this modification at their March meeting, and the final report was sent to Ofgem.

However, the Modification was sent back to Workgroup stage by Ofgem on 11 June 2019¹. The CUSC Panel reviewed the resubmitted Draft Final Modification Report on 30 August 2019, and decided that the changes to report and legal text were material at a Special CUSC Panel on 12 September 2019, and as such sent the modification to a second Code Administrator Consultation for five working days.

Updates to the document post Ofgem send back by the Workgroup are documented throughout Section 4 of this document, where the Authority have requested changes be made. There are also updates on the workgroup discussions held post send-back on

¹ <https://www.nationalgrideso.com/document/145236/download>

p25-p28 of Section 4 of this document. The legal text has also updated as per Ofgem's request. This can be found in Annex 7 of this report.

CMP303 was proposed by EDF Energy and was submitted to the CUSC Modifications Panel for its consideration on 27 July 2018. The Panel decided to send the Proposal to a Workgroup to be developed and assessed against the CUSC Applicable Objectives. The Authority determined that the proposal should not be considered on an Urgent timescale but follow accelerated timescales.

CMP303 aims to make part of the TNUoS charge more cost-reflective through removal of additional costs from local circuit expansion factors that are incurred beyond the connected, or to-be-connected, generation developers' need. The Workgroup consulted on this Modification and a total of 9 responses were received. These responses can be viewed in Section 5 of this Report.

Workgroup Conclusions

At the final Workgroup meeting, Workgroup members voted on the Original proposal and nine WACMs. All members voted that the Original Proposal better facilitated the applicable CUSC objectives and that WACMs 1,2,3,8 and 9 better facilitated the applicable CUSC objectives.

Code Administrator Consultation Responses

Seven responses were received to the first Code Administrator Consultation. A summary of the responses can be found in Section 10 of this document.

Six of the seven respondents agree with the implementation approach for CMP303, with particular emphasis put on implementation prior to the then upcoming CfD auctions. Further comments to the Code Administrator Consultation can be found in Section 10 and Annex 8 of this document.

Second Code Administrator Consultation Responses

Four responses were received to the second Code Administrator Consultation. Three of the four respondents agree with the implementation approach for CMP303. A summary of the responses can be found in Section 10 of this document and the full responses can be found in Annex 13 of this report.

CUSC Panel View

At the CUSC Panel meeting on 25 October 2019, the Panel voted on CMP303 against the Applicable CUSC Charging Objectives and by majority recommended that the Original and WACM3 better facilitated the CUSC objectives than the baseline.

This Final Modification Report has been prepared in accordance with the terms of the CUSC. An electronic copy can be found on the National Grid ESO website along with the CUSC Modification Proposal Form.

<https://www.nationalgrideso.com/codes/connection-and-use-system-code-cusc/modifications/cmp303-improving-local-circuit-charge-cost>

2 Original Proposal

Defect

When a new local circuit is built to enable the export of new generation, extra costs may be incurred on additional functionality that is unrelated to the needs of said generation. For example, on an island requiring a DC connection, the transmission owner would naturally build the HVDC infrastructure as one-way, only allowing flow from the island, where the generation is located, to the mainland. There may be a cost difference if the link is built as bidirectional. The relevant Transmission Owner (TO) may choose to incur any such incremental expenditure making the link bidirectional, if it felt that there were security benefits in terms of, under certain scenarios, securing demand. That is one example; there may be other additional functionality to be included in AC local circuits that are at the behest of the transmission owner or system operator, and not related to the needs of the generator.

The defect is that, absent clarification of the exclusion of these extra costs, they are very likely to be included in the actual costs used to calculate the expansion factor and hence the relevant local circuit charge, meaning that relevant generators are facing a local circuit charge that is not fully cost-reflective.

What

The calculation of local circuit expansion factor should only include costs relevant to and needed by the connected generators. The incremental cost of extra functionality that the TO chooses to add, of wider benefit, should not be included. If the cost is already excluded under CMP301, if passed, then it could not also be excluded under this mod.

Why

If the calculation of the expansion factor and hence LCT, includes the cost of extra functionality included for wider societal/system benefits unrelated to the relevant generators' needs, the charge will not be cost-reflective as to what is being provided to connect up relevant generators, as opposed to what is additionally being provided for other transmission users.

How

Baseline CUSC says at 14.15.75 that AC cable and HVDC circuit expansion factors are to be calculated on a case by case basis using actual project costs (Specific Circuit Expansion Factors). It is suggested that a following paragraph be added, to make clear that where there are extra costs unrelated to the relevant generators' needs, they should be excluded from the relevant expansion factor. The TO will provide the cost information on a case by case basis (to Grid), removing any additional costs not solely for the developer. System Operator and Transmission Owner Code (STC) procedures 13 and 14 already allow for the TO to provide relevant information to the TNUoS charging team, using broad and inclusive wording, so they will not need amendment.

3 Proposer's solution

Baseline CUSC says at 14.15.75 that the AC sub-sea cable and HVDC circuit expansion factors are to be calculated on a case by case basis using actual project costs (Specific Circuit Expansion Factors). It is proposed, with this Modification that a following paragraph be added to make clear that the incremental costs, as identified by the TO, of extra functionality unrelated to the developers' needs, should be excluded.

Does this modification impact a Significant Code Review (SCR) or other significant industry change projects, if so, how?

The Proposer's view is that this change falls outside the scope of the "targeted charging review" SCR. This defect has certainly not been documented or discussed within the TCR seminars or documentation.

Consumer Impacts

There will be a diluted adverse impact on the charges faced by others – at present our understanding of the operation of EC838/2010 is that in today's climate it is other generators that would be affected, not Suppliers/consumers, though this may not always be the case.

4 Workgroup Discussions

The Workgroup convened 8 times between October 2018 and August 2019 to discuss the perceived issue, detail the scope of the proposed defect, devise potential solutions and assess the proposal in terms of the Applicable CUSC Objectives and review the responses to the Workgroup Consultation.

The Workgroup discussed the key attributes under CMP303 and these discussions are described below.

CMP303 seeks to change Section 14 of the baseline CUSC to amend part of the current TNUoS charge to be more cost-reflective through the removal of additional costs from local circuit expansion factors that are incurred beyond the connected, or to-be-connected, generation developers' needs.

The Workgroup members were advised that the current defect, identified in CMP303, comes to the fore in situations which involve the construction of a new HVDC local circuit, which is used to enable the export of new generation. In such scenarios, extra costs may be incurred, often because of additional functionality which is not always related to the needs of the aforementioned generation, but actually arise from additional functionality sought by the Transmission (or Distribution) Owner.

In order to illustrate this issue, a scenario was presented by the Proposer with an island requiring a DC connection to the National Energy Transmission System (NETS) for a connecting generator. In principle, the Transmission Owner would more than likely need to build a HVDC link as a one-way set up (in the opinion of the Proposer), which would only allow energy to flow from (and not 'to') the geographic location (in the main instance Scottish Islands) where the generation is located, to the mainland Great Britain energy networks.

However, if it was apparent that there were potential security benefits, for instance securing demand in uncertain situations, the relevant Transmission Owner may consider making the link bi-directional (so that energy could flow both 'from' and 'to' the connected location). However, there was expected to be a cost difference to the Transmission Owner in such instances of building a bi-directional transmission link compared with building a mono-directional transmission link. There are potentially other scenarios where bi-directional functionality could be considered by a relevant Transmission Owner. This additional functionality may see the Transmission Owner incur extra costs, especially when one takes into consideration additional functionality (over and above what is needed for the connecting generator) which may be required in terms of local AC systems.

In the formative stages of this Workgroup, the Proposer highlighted to the Workgroup that factors as part of this modification are to be calculated on a case by case basis, using actual project costs. The relevant Transmission Owner would provide the cost information to National Grid Electricity System Operator (NGESO), resulting in the removal of any additional costs not solely needed for connecting the developer's generation project. It was also highlighted that the STC Procedures 13 and 14 are currently set up to allow NGESO access the relevant information from the Transmission Owner, and as such will not need to be amended to allow for this modification.

The Proposer stated to the Workgroup that the solution should change the TNUoS charging regime to only include relevant costs associated with the needs of the connected generators. In that case, if the Transmission Owner makes a decision to invest in extra functionality, this should not be recovered from those generators.

Timescales and CfD Auctions

The Workgroup discussed the timescales for this modification and noted that they were dictated in some way by the 2019 Contracts for Difference (CfD) auctions. The Workgroup believed that if this modification were to be implemented, then it would give any participants in the CfD auction the ability to compete in this auction efficiently, by them having the ability to forecast the local circuit tariff elements of TNUoS charging (which are a material factor for the parties concerned when seeking to participate in the auction)².

In order to do this effectively, said participants would need knowledge as to whether the Transmission Owner in question is proposing to add further cost to TNUoS charges by constructing a link with extra functionality, which may not necessarily be needed by the developers of generation that are dependent on the link in question. It was highlighted to the Workgroup by the Proposer that this modification had the ability to provide such clarity to generation developers in terms of the potential of extra recovery of TNUoS costs when additional functionality is included in the link due to needs over and above those required by the relevant generation developers.

However, at the time of compiling this Final Modification Report, the CfD auction has now been held.

Interactions with Other Modifications

CMP301: Clarification on the treatment of Project Costs associated with HVDC and subsea circuits was raised by NGESO to CUSC Panel on 29 June 2018. In terms of the aims of CMP301, a previous modification (***CMP213 - Project TransMIT, the Authority's review of electricity transmission charging and associated connection arrangement***) introduced specific expansion factors for HVDC and subsea circuits. However, it is NGESO's opinion that the existing relevant legal text within the CUSC is open to interpretation – and as such the CMP301 proposal would cement the interpretation made by NGESO to ensure consistency with onshore circuits.

CMP301 has been to The Authority and was sent back for further information to be included in the Draft Final Modification Report, a direction received by the Code Administrator on 05 November 2018³.

The Code Administrator sent CMP301 back to The Authority for decision in Q1 2019, with the Authority approving the modification in June 2019⁴, for an April 2020 implementation. As the decision on CMP301 was not received before 31 January 2019, the resulting change was not included in the TNUoS charges for 2019/2020. Due to the closely linked subject matter, the CMP303 Workgroup would like to clarify in this report

² This auction occurred in September 2019.

³ https://www.nationalgrideso.com/sites/eso/files/documents/CMP301_send-back_letter.pdf

⁴ <https://www.nationalgrideso.com/document/145226/download>

that throughout the discussions, CMP301 and its potential implications in conjunction with CMP303 have been considered.

The CMP303 Workgroup also noted that in the initial proposal, that the incremental costs of extra functionality (such as bi-directionality) that a Transmission Owner may choose to add should not be included. If the cost is already excluded by the potential implementation of CMP301, then a similar exclusion could not take place under CMP303.

Benefits of the Modification

The Workgroup spent some time considering the benefits of the original proposal. One of the main considerations around the benefits of CMP303 was the level of cost reflectivity in generator TNUoS provided by the proposed change.

Understanding the Impacts of Wider and Local Tariffs, and Generation and Demand Concerned

In order to fulfil the requirements of this modification, the Workgroup agreed that the costings of mono-directional vs bi-directional transmission links would need to be understood in full. The Workgroup considered this and decided that the most efficient way to do this would be to engage with a HVDC supplier.

It was also agreed within the Workgroup that there may be Capex vs Opex cost considerations (as between a mono-directional vs bi-directional transmission link) which the Workgroup may need to consider to get a full picture of the benefits of CMP303. The Workgroup also recognised, that in theory there could be a distinction in regards to whether the modification would apply solely to the Scottish Islands, or to the GB Energy Network as a whole. The Workgroup noted that CMP303 deals only with the treatment relating to charging arising from the sub-sea cables and any associated convertor stations. Therefore, any equivalent sub-sea Transmission assets anywhere in GB should be treated in the same way. The Proposer and the workgroup agreed that the CMP303 solution would be applicable across GB as a whole where similar sub-sea transmission links were built.

The Workgroup also heard a suggestion that any alternatives should be passed on to the NGENO TNUoS charging team as soon as available, so background work could be carried out to map in each potential scenario. This was seen as beneficial as it gives the teams within the NGENO sight of potential permutations which could impact the final forecasting of TNUoS.

During the course of the work undertaken, the Workgroup looked to address Terms of Reference a) and b), namely understanding the impact of the modification on wider and local tariffs, and on generation and demand concerned. It became apparent that it would be difficult to quantify exact amounts for previous projects. The Workgroup agreed that in terms of mono vs bi directionality, that there was a small difference, which was not quantifiable from previous projects, but this should be taken in to account with projects going forwards.

Annex 11 details further analysis of mono vs bi-directionality costing effect that was undertaken by the ESO, where certain variables from 0.5%-10% were modelled. The Workgroup felt that 0.5-5% were the most plausible scenarios. Whilst a figure has not been quantified, the analysis has facilitated a methodology which future projects will be able to apply thanks to the modelling undertaken within this process.

Consideration of the overall benefits of the change vs Impacts on End Consumers

Consideration was given in some detail to the impact CMP303 would have on generation and demand. In the initial stages of the Workgroup, the aim was to quantify the benefits of the proposed solution under CMP303, with cost reflectivity being the central theme of this work. The Workgroup endeavoured to understand how tangible and detrimental the current charging baseline error, as perceived by the Proposer, was within the CUSC. Security of supply in specific geographic areas of the Scottish Islands was discussed within the Workgroup. It was said by some members of the Workgroup that as things stand, security of supply benefits may vary between islands. There was agreement that having bi-directionality of a future transmission link would further reinforce islands and could only add to their security of supply level.

The Workgroup broadly agreed that in the context of this proposal, a generator would only need a mono-directional link, but there were instances whereby functionality that is not required by the generator (such as moving from mono-directional to bi-directional) would bring additional benefits to network operators and / or demand when compared to a mono-directional link

Clarification of Source and Process of Information to determine the cost to be reapportioned

As things currently stand costing information available from the Transmission Owner to NGENSO would only be split out through asset/asset group. NGENSO does not currently get the enhanced level of detailed information from the Transmission Owners needed to determine any additional costs associated with enhancing a transmission link from mono-directional to bi-directional.

A consideration of bi-directional functionality vs costs was undertaken by the Workgroup. NGENSO put forwards the opinion that any work it undertakes in regards to the costs discussed in the CMP303 proposal would come from analysis of cost data currently collected from generation by the Transmission Owner.

A Workgroup member stated that it was their expectation that there wouldn't necessarily be an interface between generation and demand. This prompted discussion in the Workgroup as to how often a Transmission Owner would provide information to NGENSO charging teams in regards to Island transmission links. The Workgroup agreed that if CMP303 were to be implemented, differing from the initial assessment, that the nature, timing and information of the data flows between the respective Transmission Owners and NGENSO would need to be clarified if the modification were to be implemented.

Workgroup Analysis

NGESO Initial Impact Assessment

After the first Workgroup meeting, NGENSO were asked to provide an initial impact assessment for the Workgroup to take into consideration. NGENSO conducted some very high level analysis on the impacts of this, using a simplistic method of applying percentage decreases to local transmission circuit tariffs. This initial analysis can be found in Annex 4.

The analysis concluded that CMP303 would have an impact on the generation residual tariff, and that the demand residual tariff would not see any impact from the implementation of CMP303. The generation residual increase could be, according to the analysis, “between 10p and 57p from the scenarios we have used, becoming less negative”. NGENSO made it clear throughout their analysis that these figures are very high level; the Workgroup will need to explore this further following the development of the solutions within the Workgroup. Once the solutions were developed, the ESO undertook further analysis on the original and raised WACMs, which can be found in Annex 11 of this report, and discussed further in Section 4 of this document.

Ofgem published a consultation document as part of the Targeted Charging Review (TCR) on 28th November 2018. Within the scope of the TCR is a holistic review of residual network charges. The future of the generation and demand residual charges, levied on all users of the transmission system, is discussed in depth. Ofgem has published a ‘minded to’ proposal which means no generator should pay residual charges; the practical effect of this would be to set the TGR to zero.

The effect of this consultation on NGENSO’s implications assessment is that the proposed cost shifting from local circuit tariff to generation residual would instead be shifted onto the demand residual. No analysis has been undertaken to assess the size of the impact on the demand residual, however it would certainly increase.

Workgroup Member Analysis

Further analysis in regards to CMP303 was undertaken by another Workgroup member, and presented to the Workgroup for their consideration. The analysis examined examples pertinent to this modification. This analysis is available in Appendix 5 of this report.

Hinckley Point

The first example given in that Workgroup member’s analysis examined the increase in Transmission Entry Capacity (TEC) from the Hinckley Point Power Station, in terms of what the lengths of overhead lines/cable that are being delivered were, and which were then subsequently multiplied by the expansion factors.

The analysis undertaken suggested that the reinforcement cost of this work at Hinckley Point was around £800m, of which around 10% could be explained by expansion factors. For Hinckley Point, 90% of the reinforcement costs are socialised. Onshore AC connections require substations, however the analysis stated that these substation costs are socialised. The example of the first 275kV circuit built in GB from Tyneside to Strathclyde was positioned to the Workgroup. This line would require 275kV substations which did not exist prior to the point at which works began. The analysis stated that this is analogous to HVDC requiring converter stations. It was also highlighted that the onshore AC assets constructed for Hinckley Point require undergrounding of DNO assets to achieve planning permission.

The analysis further described that these costs are socialised and not assigned to the generator concerned, however the cost of undergrounding/subsea installation to the islands required by the physical geography is currently fully allocated to the island generator users. This would back the Proposer’s point that Island located generators may be discriminated against under current arrangements, if we compare these to other points of interest on the transmission network.

Pembroke to Walham

AC substations and AC transmission were considered within the Workgroup member's analysis, giving the example of the Pembroke to Walham 400kV substations. The analysis highlighted that treating those differently to HVDC is not necessarily discriminatory. Further analysis was presented which stated that AC transmission circuits require more assets than just cables or lines in order to function. One such example of this is the Harker to Strathavan reinforcement in the 1990s.

Further exploration of the optimisation of capacity for lower costs and charges was detailed. It was underlined that Offshore Transmission Owner (OFTO) assets are sometimes designed and built by offshore developers, but it was opined by NGENSO that the OFTO cannot have fully bespoke assets in the majority of cases. It was opined within the Workgroup that generation developers control the ratings and costs of these OFTO assets and can consequentially manage their TNUoS charges. Island generation developers do not control the size or cost of assets, which are determined by the Transmission Owner, and subsequently, island generation developers are not able to manage TNUoS charges, creating a disparity in the market, in the opinion of some Workgroup members.

An example, based on the HVDC cost model developed for Greenlink and Mali interconnector projects, which were undertaken by Statkraft was examined. Statkraft calculated that the additional costs of taking the Shetland HVDC connection from 600MW to 800MW is less than 4% for the 33% capacity increase. The larger capacity would reduce TNUoS by a tangibly larger amount than the increase in capital cost. The provider of the analysis stated that in their opinion the offshore generation developer could manage and exploit benefits of scale as highlighted, whereas the island generation developer cannot, which highlighted similar themes as put forward by the Proposer of CMP303.

Cost effectiveness of HVDC – is it always more expensive?

The Workgroup member who provided the analysis also opined that a HVDC transmission link can have a lower cost than an AC transmission link. It was mentioned that there may be assumptions within industry that HVDC based solutions are always more expensive than AC solutions, however this is not always the case. The competition to replace the Shetland Power Station demonstrated that an HVDC transmission link (with converters and cables) was the most cost effective.

Some Workgroup members often stated their belief that HVDC island transmission links provide security of supply, something which this analysis concurred with. A pertinent example put forwards by the analysis was that the Shetland Islands are not connected to the GB transmission grid and the power station requires replacement. A competition to replace that power station identified the lowest cost solution as an HVDC transmission link from Shetland to the GB mainland. The cost of the HVDC part of the solution was £279m if a transmission link is built to Shetland to enable generation exports, the bi-directional transmission link will also provide a supply to the island to replace the power station with a capital saving of £279m.

The avoided cost could be deducted from the actual cost of the HVDC transmission link before TNUoS charges are calculated, which may arguably improve the cost reflectivity.

The same principle of security of supply would apply to other remote islands, and as cost saving information is not to hand for these islands therefore the same percentage cost reduction for transmission charging purposes should be applied to other remote islands, as with HVDC links for Shetland. The Workgroup gave this issue some consideration in regards to how this was recovered via TNUoS. A Workgroup member highlighted that that this could be applied through the residual across all UK users.

The analysis provided, further explored the geographic and historical nature of TNUoS. The work undertaken shows that for the Hinckley Point transmission reinforcements, 90% of the costs were associated with works other than the 400kV overhead lines and cables themselves. When the Beaulieu Denny 400kV upgrade was completed there was a reduction in the northerly TNUoS charges within the GB market as a consequence of the decreased unit capacity costs. The analysis undertaken contended that both aforementioned projects incurred investment costs but did/will not raise transmission charges commensurately, with any negative impact to end users. There was broad agreement in the Workgroup on the matter.

Based on their geographical position within the GB Energy Market, old and new assets have been constructed at lower voltages than 400kV for “permitting or historic reasons”. According to the analysis, lower transmission voltages may incur higher local TNUoS charges on generation users. However, there is no commensurate reduction in transmission charges for demand users.

It was put forward that transmission reinforcements are increasingly expected to involve sections of more expensive underground cable in order to satisfy aesthetic expectations from the general public, which have become more prevalent in recent years. The analysis henceforth suggested that to circumnavigate the “arbitrary nature” of transmission charges due to “historic or geographical reasons”, a standard expansion factor could be applied to all transmission assets with no consideration given to the voltage or type of the asset.

In summary, the Workgroup member’s analysis concluded that AC transmission networks have a tangible requirement for substations to function efficiently and transmit power. The substations house switchgear and protection, transformers, reactors, capacitors, stat-coms, series capacitors and quad boosters which are required to deliver power transfer of AC.

The analysis further concluded that these afore mentioned assets are not multiplied by the expansion factors whereas HVDC converters are. Thus 50%-90% of the costs of building/reinforcing AC transmission networks are not included in AC the expansion factors. AC transmission networks require ancillary services to operate them, including reactive power, dynamic voltage control, inter-tripping etc. Furthermore, it was put forward that these costs are not incurred on HVDC transmission links.

OFTO linked generation developers control the sizing of their assets and can cost optimise, whilst inland generation developers cannot. HVDC transmission links also provide security of supply on remote islands. A Workgroup member argued that the nature of network transmission charging is somewhat arbitrary, whilst generally cost reflective there are instances when this is not the case. A standard ‘km’ based expansion factor regardless of circuit voltage or asset type would remove such idiosyncrasies.

One Workgroup Member wanted the Workgroup to have some grasp on the potential cost savings on a unidirectional HVDC system noting there was a risk that Workgroup members may think that unidirectional flow would save 50% of the costs. The Workgroup member noted that they had not seen any technical papers or proposals as to how such a system would be designed.

Therefore, the Workgroup member presented a very high level off ballpark assessment of the potential cost savings a unidirectional HVDC link might bring. It was mooted by this Workgroup member that the cost of converters might, say, be 40% of the overall system costs (60% being cables). For unidirectional flow the cost saving was mooted to be at the island end with unidirectional power flow; i.e. rectifier to convert AC to DC. So the saving would be on one of the two converters; i.e. on 20% of the cost base. It was assumed that half the cost of the converter was associated with power electronics and controls (other costs such as land, civil works, transformers, busbars, switchgear, etc would be the same) and therefore the cost savings would apply to 10% of the total HVDC cost.

Assuming the cost differential to be half for the reduced power electronics (e.g. diodes vs IGBTs) the overall saving would be 5% of the total HVDC cost. The analysis noted however that bidirectional flow would be required to energise the AC network and provide power to the wind turbines during no wind periods and to produce a 50Hz AC waveform on the island which could incur additional costs such as synchronous compensators or standby generators which would eat into any cost savings.

Security of Supply

It was argued within the Workgroup that HVDC island transmission links, where bi-directional, may provide security of supply to island networks. An example was given, illustrating that the Shetlands are not connected to the GB electricity grid and the power station there requires replacement. A competition to replace that power station identified the lowest cost solution as an HVDC transmission link from Shetland to GB mainland. The cost of the HVDC part of the solution was reported as £279m if a transmission link is built to Shetland to enable generation exports, the transmission link would also provide an island supply to replace the power station with a capital saving of £279m.

It was stated that this avoided cost could be deducted from the actual cost of the HVDC transmission link before TNUoS charges are calculated. The same principle of security of supply applies to other remote islands, and as cost saving information is not to hand for these islands the same percentage cost reduction for transmission charging should be applied to other remote islands with HVDC links as for Shetland.

Shetland as a charging model

The suitability of using the example of the Shetland HVDC link was discussed by the Workgroup, and it was agreed that more tariff analysis would need to be conducted into this matter. The £279m cost of the Shetland HVDC transmission link example was proposed and the costs of the link including the back-up diesels. The reasoning as to this was that the diesel generation would match the distributional demand whilst the cables were down. A belief was expressed by a Workgroup member that this cost would be picked up through all GB distribution use of system (DUoS) charging, and if this was the case, that it should be applied to all similar island HVDC connections. The Workgroup discussed whether the interaction between TNUoS and DUoS should come

about, concluding that it should not, as this modification is dealing solely with TNUoS charging. This led to a discussion as to whether a solution involving Distribution Network Operators should be sought; however, due to the previous point raised, it was decided against.

Potential Alternatives put forward by the Workgroup

The initial CMP303 solution pointed to CUSC section 14.15.75, which highlights that AC sub-sea cable and HVDC circuit expansion factors are to be calculated on a case by case basis using actual project costs (Specific Circuit Expansion Factors).

As well as the initial solution proposed, there were four initial potential alternatives proposed by one Workgroup member. They were as follows:

1. Remove all converter station costs from HVDC charging

This potential alternative sets out that industry would think that the provision of equipment/cabling would provide additional functionality, which may not have initially be required but is inherent with the installation of said equipment/cable. The Workgroup discussed the possibility that due to this, potential alternative 1 needed to be revisited in terms of the scope.

The Workgroup concurred that the system could get the value with only the Transmission Owner paying. The possibility of raising a new modification to include this concern within a new defect was discussed. It was also explored whether a link with a thyristor element would provide additional functionality but the cost saving would be reduced. It was also discussed that some of the savings are being taken away from the costs unnecessarily.

An argument was put forward that power electronics costs would also exist within the AC world as well as DC, and that the DC design choice has value as it avoids other costs. In this respect, potential alternative 1 would remain in scope due to this. It was highlighted that Ofgem would have the final scrutiny within any “needs case”, and associated efficiencies.

The Workgroup were made aware that the Authority would have the ultimate recourse on making the decision on whether this potential alternative was within the scope of the defect.

The Workgroup came to a conclusion on whether the first potential alternative was in scope of the modification defect. The Workgroup agreed that the potential alternative was in scope of the modification and should be brought forwards accordingly.

Potential Alternative 1a – Wider System Benefits of HVDC

This alternative identifies additional functionality of HVDC local circuits that is unrelated to the needs of the generation whose export is facilitated by the HVDC local circuits. It proposes to quantify the costs of this additional functionality by examining the costs of equivalent plant or services. The costs of the equivalent plant or services are then deducted from the HVDC costs entered into the generator local circuit TNUoS charge calculation to reduce the charge the relevant generators pay.

The detail behind this potential alternative is located in Annex 6 of this document.

2. For Island HVDC charges, recognise the alternatives of making a supply to the islands via distribution rated HVDC and subtract this benefit from the cost before applying TNUoS. As these costs are clear for Shetland, use Shetland as the model and apply same percentages to HVDC link to the Western Isles.

The second initial potential alternative, suggested within the Workgroup, looked at how Island charges could reflect and recognise security of supply benefit by subtracting from cost, before applying TNUoS charging. It was argued that a similar percentage applied to Shetland could apply to other islands. A belief was discussed within that Workgroup that any such application should be determined by Ofgem, as project specific figures would be more cost reflective than the application of a generic percentage, based solely on one (Shetland) island network. Several Workgroup members agreed on the matter.

After further discussion, the Workgroup decided to break down potential alternative 2 into three separate potential alternatives, which will be referred to as 2(a) (mirroring the Original), 2(b) and 2(c) respectively. It was agreed that the term “distribution rated HVDC” should be removed from the alternatives also.

Potential alternative 2(a) - For Island HVDC transmission charges, recognise the alternatives of making a supply to the islands and subtract this benefit from the cost before applying TNUoS. As these costs are clear for Shetland use the Shetland percentage as the model and apply same percentages to HVDC link to the Western Isles and Orkney.

Potential alternative 2(b) – For Island HVDC transmission charges, recognise the alternatives of making a supply to the islands and subtract this benefit from the cost before applying TNUoS.

It was highlighted during Workgroup discussions that the relevance of using the Shetland specific percentage as an example may have some flaws; primarily on the grounds of being less cost reflective. One such issue was that Shetland is approximately 150km from the Scottish Mainland, whereas the Western Isles and Orkney are considerably closer. This would likely see a difference in the actual costs for the respective transmission links. As such, whether it is sensible to utilise the Shetland calculated percentage as a like for like example to other locations (such as the Western Isles or Orkney) was disputed.

Potential alternative 2(b) reflects this thinking, by removing the reference to applying the Shetland percentage to any other island groups from this potential Alternative. Instead the percentage would be calculated on a case by case basis meaning that the Shetland percentage would apply only to the Shetland based local circuit TNUoS whilst the Western Isles and Orkney, for example, would have their own Western Isles or Orkney local circuit TNUoS charges (based on their own respective percentages).

Potential alternative 2(c) – Pro Rated S/D

For HVAC subsea cable connections or new HVDC connections that constitute a generator local circuit for the purposes of TNUoS charging, the proportion of the

costs of the connection for import flows from the mainland to the island, for example for demand, should not be charged to the relevant generators. This is achieved by deducting (pro-rata) a proportion of the cost of the connection from the relevant cost entered to the generator local circuit TNUoS calculation. This pro-rata proportion shall be calculated using the import / generation export ratio.

It was highlighted that potential alternative 2(c) may allow the inclusion of import flows (from the mainland to the island) for considerations other than demand, for example future interconnector requirements.

3. Given the discrepancies in charging and the historical and geographical accidents and associated costs relating to either: the remote islands; or the densely populated areas of England; or the landscape designations; apply a single global GB expansion factor to all assets: AC and DC; cable and overhead line; and all voltages; to remove these idiosyncrasies.

The initial iteration of potential alternative 3 applies a single global expansion factor for all relevant assets. It was suggested that this potential alternative 3 was possibly out of scope of the original CMP303 defect. The Workgroup discussed this at length, and eventually deciding that potential alternative 3 was not in scope of the modification. The Workgroup also agreed that potential alternative 3 would materially affect all Scottish tariffs, and would result in distortions in cost reflectivity. Potential alternative 3 was not subsequently formally submitted to become a WACM and was discontinued for the purposes of this Workgroup.

4. Combination of 1&2

Options 4(a) and 4(b) are hybrids of potential alternative 1, with the three combinations which were borne out of potential alternative 2:

4(a) Remove all converter costs for HVDC charging, and for Island HVDC charges, recognise the alternatives of making a supply to the islands via distribution rated HVDC and subtract this benefit from the cost before applying TNUoS. As these costs are clear for Shetland use Shetland as the model and apply same percentages to HVDC link to the Western Isles.

4(b) Remove all converter costs for HVDC charging, and for Island HVDC charges, recognise the alternatives of making a supply to the islands via distribution rated HVDC and subtract this benefit from the cost before applying TNUoS.

These combinations look to enhance the suggestions made in potential alternative 1, by adding 2(a) and 2(b) alternative solutions to form a potentially more encompassing solution in the opinion of some Workgroup members. As the Workgroup agreed the solutions outlined in potential alternatives 1 and 2 fell within scope of the original CMP303 proposal, then logically, the hybrids documented here should also.

Potential alternative 4(b) would be based on the island specific costs that would be associated with building an equivalent distribution link to the GB mainland instead of the transmission link on a case by case basis.

5. Combination of 2&3

As potential alternative 3 was discontinued, so potential alternative five, which combined a hybrid of potential alternates 2 and 3, followed suit.

Post Consultation Discussions

The Workgroup convened on 6 occasions post workgroup consultation to discuss the responses to the consultation. The Workgroup considered these responses, which can be found in Annex 4 of this document.

Summary of Consultation Responses

- The Workgroup consultation responses show a broad support for the intent of the modification. When asked if the original better facilitated the applicable CUSC objectives, all 9 respondents to the consultation responded in a positive fashion, and this was duly noted by the Workgroup. National Grid Electricity System Operator did however caveat their answer, responding that there may be a neutral or negative impact to end consumers.
- In terms of the implementation approach, 8 respondents responded positively, highlighting the need for implementation prior to the 2019 CfD auctions. National Grid ESO however disagreed with this approach, noting that they believed this aspect of the proposal needed more development.
- When asked for additional comment on the modification, there were several points raised which were considered by the Workgroup. There were comments which suggested slight concern that other benefits of HVDC or HV Subsea arrangements have not been considered by the Workgroup in a short timeframe. One respondent noted their support for the principles of cost reflectivity, outlined in CMP303, and noted that these are best achieved not only by carving out costs identified as relating to bidirectionality, as in CMP303's core proposal, but also by reflecting the value an HVDC transmission link brings to users. One respondent helpfully noted that the Workgroup should be mindful of the Authority's decision on CMP213.
- SHEPD raised an alternative request – this was considered and welcomed by the Workgroup. Please see following section of this report entitled "SHEPD Alternative Request".

SHEPD Alternative Request

- SHEPD raised an alternative request which was considered by the CMP303 Workgroup. The alternative request can be found in full in Annex 6 of this report. SHEPD's alternative request originates in the premise, supported by whole system principles, that it is for the relevant customer (e.g. DSO / NGESO) to determine its need, and to make a valuation of the avoided costs and / or "fair value" of relevant assets / services which would be used by / of benefit to those customers in meeting that need. SHEPD highlight their view that there should also be a correct allocation of cost, applied towards those customers who benefit from shared use of an asset.

- SHEPD highlighted that in their view the alternative approach should be reflected in any CMP303 proposal taken forward to implementation where there is an attempt made to reflect the benefit or value of an asset and / or other services to other customers / users. SHEPD stated that they believe that it is for those parties who will benefit from the shared use of the asset and / or associated services to determine both: i) the scale and nature of the need that those parties have, and ii) the value that they place on associated assets or services. This would take proper account of need and, following whole system principles, would be more likely to result in a cost efficient / cost reflective outcome. They therefore recommend that CMP303 is modified to incorporate this process of engagement with, and determination of need by, relevant parties / customers.
- SHEPD, as a potential future user of island HVDC transmission links, identified its needs in relation to these distribution systems. Subject to consultation and Ofgem's approval, SHEPD's avoided costs / fair value contribution methodologies have been proposed for Shetland, and associated proposals for the Western Isles are under assessment. As such, in the case of the Scottish islands which are the focus of current transmission link developments, SHEPD's contribution methodology may be utilised to determine the need for, and value of, DSO / distribution contributions towards transmission asset costs.
- The solution put forward by SHEPD uses the value of an HVDC transmission asset to other customers/ users is determined and applied on the basis of an assessment of need and valuation of use of a given asset / services by those customers. SHEPD agree that it would be reasonable that the "avoided cost" of meeting that need by other means need would represent the maximum contribution those customers would be likely to make.

Workgroup Consideration of Alternative

The SHEPD alternative request was considered by the Workgroup. One member stated a belief that this would be a GB solution, as opposed to just a Scottish Island solution, as it would apply in similar circumstances within GB. One Workgroup member disagreed, and thought that the alternative request did not have merit, highlighting that import to the Western Isles could be modelled on to the Isle of Skye for instance. It was also highlighted by one member that the SHEPD alternative brings up issues around utilisation, and is a point for discussion. In regards to Shetland, some of the Workgroup opined that the proposed solution hasn't been finalised in terms of a decision from Ofgem. The NGENSO representative stated that it may be unique to Shetland today, but that should not preclude the solution being applied to any equivalent location in GB, and that there were concerns in regards to the scope of the modification. The defect originally was around generator paying for a functionality (bidirectionality) and how that would be recovered.

- Whilst the Workgroup found some merit in the alternative request provided by SHEPD, this was not taken forwards by the Workgroup in the form proposed. During Workgroup 5, the Workgroup contacted SHEPD to discuss the proposal further. After the discussions, it was decided that the aspects of the alternative request should to be considered as a formal WACM (it subsequently became WACM4 – see below for further details).

Alternatives Proposed and Voting

Member	Alternative 1	Alternative 2	Alternative 3	Alternative 4	Alternative 5	Alternative 6	Alternative 7	Alternative 8	Alternative 9	Alternative 10
Step 1	All based on the Original - Accept the Bi/Mono							N/A	N/A	N/A
Step 2	Converter - recover 50%	Converter - recover 100%	Converter - Case by Case	Offset into demand TNUoS	1+4	2+4	3+4	Pro-rata	2+8	3+8
Proposer	Garth Graham	Nigel Scott	Nigel Scott	Garth Graham	Garth Graham	Nigel Scott	Nigel Scott	Nigel Scott	Nigel Scott	Nigel Scott
Supported by: Yes, No Abstain										
Paul Mott (Proposer Original)	YES	YES	YES	YES	YES	YES	YES	YES	YES	YES
NGESO - Eleanor/Harriet	YES	YES	YES	YES	YES	YES	YES	YES	YES	NO
Garth Graham	YES	NO	YES	YES	YES	NO	YES	NO	NO	NO
Simon Swiatek	YES	YES	YES	YES	YES	YES	YES	YES	YES	YES
Nigel Scott	YES	YES	YES	YES	YES	YES	YES	YES	YES	YES
Sharon Gordon	YES	ABSTAIN	YES	YES	YES	ABSTAIN	YES	ABSTAIN	ABSTAIN	ABSTAIN
Guy Nicholson	ABSENT	ABSENT	ABSENT	ABSENT	ABSENT	ABSENT	ABSENT	ABSENT	ABSENT	ABSENT
Total	6 OUT OF 6	4 OUT OF 6	6 OUT OF 6	6 OUT OF 6	6 OUT OF 6	4 OUT OF 6	6 OUT OF 6	4 OUT OF 6	4 OUT OF 6	3 OUT OF 6
Supported by Chair if applicable (yes / no)										NO
WACM Reference	WACM 1	WACM 2	WACM 3	WACM 4	WACM 5	WACM 6	WACM 7	WACM 8	WACM 9	

After thorough consideration by the workgroup, a total on 10 alternatives to the modifications were raised. Please see below explanations of these alternatives:

Alternative 1 (Based on Original Proposal): Converter recover 50% [WACM1]

This Alternative includes the solution in the Original Proposal as regards charging for mono/bi-directional functionality. In addition, this proposal also sets out that 50% of the cost of the HVDC converter stations needed for HVDC links will be removed from the circuit expansion factor. This is based on the analysis undertaken as part of the CMP213 Workgroup deliberations (see, for example, the SSE generation response to the CMP303 Workgroup consultation at Annex 3 and in particular, Questions 3 and 5 and footnote 1) which identified that elements of HVDC converter stations have similar characteristics to onshore transmission assets that are, within Section 14 of the CUSC, not charged on a local circuit basis. These elements amount to approximately half the cost of the converter station costs. This Alternative would ensure an equivalent, non-discriminatory, approach to those costs for HVDC links as occurs with other transmission assets that perform similar functions.

Alternative 2 (Based on Original Proposal): Converter recover 100% [WACM2]

This Alternative includes the solution in the Original Proposal as regards charging for mono/bi-directional functionality. In addition, this proposal also sets out that 100% of the cost of the HVDC converters from the costs entered into the generator local circuit TNUoS calculation will be removed on the basis that the normal onshore AC methodology does not include substations. The cost will be recovered via residual charge. In the view of the proposer, the original proposal does not identify this aspect of HVDC links. The proposer argues that this alternative should be applied in concurrence with the original proposal, whereby the bi-directional component of HVDC cost should not be recovered by generators to whom it is not relevant. However, this alternative will provide additional socialisation of HVDC costs, to better achieve the CUSC objectives, through recovery of HVDC converter costs via residual charges, in line with normal onshore AC methodology.

Alternative 3 (Based on Original): Case by Case [WACM3]

This Alternative includes the solution in the Original Proposal as regards charging for mono/bi-directional functionality. In addition, this proposal identifies additional functionality of HVDC local circuits that is unrelated to the needs of the generation whose export is facilitated by the HVDC local circuits. It proposes to quantify the costs of this additional functionality by examining the costs of equivalent plant or services. The costs of the equivalent plant or services are then deducted from the HVDC costs entered into the generator local circuit TNUoS charge calculation to reduce the charge the relevant generators pay. The additional functionality (in the view of the proposer) is as follows.

1. Reactive power provision
2. Voltage control
3. Power flow control (quadrature booster functionality)
4. Black start

Alternative 4: (Based on Original) Offset into Demand TNUoS [WACM4]

This Alternative includes the solution in the Original Proposal as regards charging for mono/bi-directional functionality. In addition, this proposal also sets out that there will be an offset element linked to the cost of a distribution variation for the network solution. The value of the offset would be determined by the Authority, whereby a proportion (determined by the Authority) of the overall total cost of the HVDC transmission link would not be recovered by TNUoS charges based on the distribution aspects met by a transmission (rather than a distribution) link. This Alternative is an 'enabling' option – it allows, within Section 14, for the Authority, if it determines it is in the wider benefit, to adopt a different approach.

Alternative 5 (Based in Original): 1+4 [WACM5]

This Alternative includes the solution in the Original Proposal as regards charging for mono/bi-directional functionality. In addition, this proposal also includes the elements of Alternative 1 [WACM1] and Alternative 4 [WACM4] combined.

Alternative 6: (Based on Original) 2+4 [WACM6]

This Alternative includes the solution in the Original Proposal as regards charging for mono/bi-directional functionality. In addition, this proposal also includes the elements of Alternative 2 [WACM2] and Alternative 4 [WACM4] combined.

Alternative 7 (Based on original) 3+4 [WACM7]

This Alternative includes the solution in the Original Proposal as regards charging for mono/bi-directional functionality. In addition, this proposal also includes the elements of Alternative 3 [WACM3] and Alternative 4 [WACM4] combined.

Alternative 8: Pro Rata [WACM8]

This Alternative does not include the solution in the Original Proposal as regards charging for mono/bi-directional functionality.

Alternative 8 identifies a method to quantify the necessary cost reduction to local circuit generator TNUoS charges as a result of the bidirectional nature of the local circuit, that bidirectional nature relating to import against the relevant generator's export for the purposes of demand and other.

For HVAC subsea cable connections or new HVDC connections that constitute a generator local circuit for the purposes of TNUoS charging, the proportion of the costs of the connection for import flows (e.g. for demand, and export on to other localities) must be recognised and should not be charged to the relevant generators. This is achieved by deducting (pro-rata) a proportion of the cost of the connection from the relevant cost entered to the generator local circuit TNUoS calculation. This pro-rata proportion shall be calculated using the import / generation export ratio. The import shall be calculated based on the maximum anticipated import needs.

Alternative 9: 2+8 [WACM9]

This Alternative does not include the solution in the Original Proposal as regards charging for mono/bi-directional functionality. In addition, this proposal also includes the elements of Alternative 2 [WACM2] and Alternative 8 [WACM8] combined.

Alternative 10: 3+8 [Not taken forward as a WACM]

This Alternative does not include the solution in the Original Proposal as regards charging for mono/bi-directional functionality. In addition this proposal also includes the elements of Alternative 2 [WACM3] and Alternative 8 [WACM8] combined.

All these Alternatives (other than 10) were carried forwards as WACMs after the vote outlined in the above table.

The Workgroup considered each WACM and associated draft legal text at the meetings on 24th January, 8th and 12th February 2019. A number of comments were noted by the Workgroup, as follows:

WACM1

It was noted that this was a relatively straightforward legal text change. The ESO representative noted that having discussed it with colleagues within the relevant charging team that they could perform the calculation, if required, assuming the relevant information was available to the ESO.

WACM2

It was noted that whilst the calculation of the first two items listed in the draft of 14.15.76 (concerning reactive power etc., and quad boosters) would appear to be

straightforward, it was unclear to some Workgroup members as to how the third item, around black start, could be calculated.

After further discussions within the Workgroup around a number of possible approaches, it was agreed that the ESO would apportion the overall cost of its contracted black start annual costs for GB (as reported via the BSUoS mechanisms to stakeholders) based on the proportion of MPANs (on the island connected via the HVDC link) to the overall number of MPANs in GB. The reason for this was (i) that information about black start annual costs is published by the ESO and (ii) it was not possible to identify location specific black start costs as the service is provided across GB. By way of illustration only, if one assumes that the annual black start cost is £24M and that the total number of MPANs is 24 million, with 6,000 of those MPANs on the island then the cost to be debited (according to the WACM3 legal text for 14.15.76) would be £6k.

In light of this clarification on the third element, the ESO representative noted that having discussed it with colleagues within the relevant charging team that they could perform the calculation, if required, assuming the relevant information was available to the ESO.

WACM3

It was noted that whilst the calculation of the first two items listed in the draft of 14.15.76 (concerning reactive power etc., and quad boosters) would appear to be straightforward, it was unclear to some Workgroup members as to how the third item, around black start, could be calculated.

After further discussions within the Workgroup around a number of possible approaches, it was agreed that the ESO would apportion the overall cost of its contracted black start annual costs for GB (as reported via the BSUoS mechanisms to stakeholders) based on the proportion of MPANs (on the island connected via the HVDC link) to the overall number of MPANs in GB. The reason for this was (i) that this information (the black start annual costs and the number of MPANs concerned) should be available to the ESO and (ii) it was not possible to identify location specific black start costs as the service is provided across GB. By way of illustration only, if one assumes that the annual black start cost is £24M and that the total number of MPANs is 24 million, with 6,000 of those MPANs on the island then the cost to be debited (according to the WACM3 legal text for 14.15.76) would be £6k.

In light of this clarification on the third element, the ESO representative noted that having discussed it with colleagues within the relevant charging team that they could perform the calculation, if required, assuming the relevant information was available to the ESO.

WACM4

It was noted that this was a relatively straightforward legal text change. The ESO representative noted that having discussed it with colleagues within the relevant charging team that they could perform the calculation, if required, assuming the relevant information was available to the ESO.

WACM5

This approach combines WACMs 1 and 4. As such it was noted that, like those two WACMs, this was a relatively straightforward legal text change. The ESO representative noted that having discussed it with colleagues within the relevant charging team that they could perform the calculation, if required, assuming the relevant information was available to the ESO.

WACM6

This approach combines WACMs 2 and 4. As such it was noted that, like those two WACMs, this was a relatively straightforward legal text change. The ESO representative noted that having discussed it with colleagues within the relevant charging team that they could perform the calculation, if required, assuming the relevant information was available to the ESO.

WACM7

This approach combines WACMs 3 and 4. As such it was noted that, like those two WACMs, this was a relatively straightforward legal text change. The ESO representative noted that having discussed it with colleagues within the relevant charging team that they could perform the calculation, if required, assuming the relevant information was available to the ESO.

WACM8

It was noted that whilst the calculation of items (a) and (b) listed in the draft of 14.15.75 (concerning demand) would appear to be straightforward, it was unclear to some Workgroup members as to how each item could be sourced.

After further discussions within the Workgroup around a number of possible approaches, it was agreed that the ESO would obtain item (a) from the relevant DNO based on the Week 24 submissions, using the distribution system 'peak demand' figure for the location. Some workgroup members were also of the opinion that, for item (b), the ESO may be able to source this transmission system peak demand information, for the location, internally from operational metering data or FES/NOA supporting information or any other existing submission(s) made by the TO to the ESO arising from STC obligations. To avoid double counting, the calculation of item (b) would not include any peak demand arising from the distribution system (as this would be included in item (a)) where that comes off the transmission system.

In light of the clarifications on (a) and (b), the ESO representative noted that having discussed it with colleagues within the relevant charging team that they could perform the calculation, if required, assuming the relevant information was available to the ESO.

WACM9

This approach combines WACMs 2 and 8. The ESO representative noted that having discussed it with colleagues within the relevant charging team that they could perform the calculation, if required, assuming the relevant information was available to the ESO.

Further ESO Analysis

To support the Workgroup's discussions, the ESO developed a Excel based tool to help understand the financial impact of the various WACMs⁵. Please see Annex 11 for further details.

The tool assumes each £1m removed from the value of the HVDC link that generation pays towards will have the same effect on TNUoS tariffs. The tool works by calculating for each WACM (using the consistent inputs) the amount to be removed from the value of the HVDC link (that generation pay towards). The tool is designed in such a way that the input variables can be changed (to reflect different assumptions) with the updates reflected in all WACMs. The summary tab shows for each of the WACMs (and the different calculation methodologies for each WACM);

1. The amount to be removed from the value of the HVDC link (that generation pay towards) – Column D
2. How this value affects the Half Hourly demand tariff – Column E
3. How this value affects the Non-Half Hourly demand tariff – Column F

Depending on the WACM chosen, CMP303 could have an impact in the range of £0.062/kW to £7.817/kW on the Half Hourly demand tariff as well as an impact in the range of 0.008p/kWh to 1.006p/kWh on the average Non-Half Hourly demand tariff. For comparison, based on the latest TNUoS forecast⁶ the 2020/21 forecasts for Northern Scotland are;

Tariff	Current 2020/21 forecast for Northern Scotland	CMP303 smallest impact	CMP303 largest impact
Half Hourly demand tariff (£/kW)	22.529	0.062 (0.28%)	7.817 (34.7%)
Non-Half Hourly demand tariff (p/kWh)	3.136	0.008 (0.26%)	1.006 (32.1%)

Ongoing Industry Changes and Competition

i) **CMP317 and the Targeted Charging Review**

⁵ <https://www.nationalgrideso.com/codes/connection-and-use-system-code-cusc/modifications/cmp303-improving-local-circuit-charge-cost>

⁶ <https://www.nationalgrideso.com/charging/transmission-network-use-system-tnuos-charges>

The Workgroup discussed interactions with CMP317 and the Targeted Charging Review. The CMP303 solution would be implemented, and local circuit charges were deemed to be connection charges, then the €0-2.50MWh limit would not apply. CMP317 states that local circuit charges are to be classified, in essence, as connection charges. For the purposes of CMP303, they would be excluded from €0-2.50MWh limit of average generation charges, but generators would still pay this as part of their local circuit charge excluded from the limit.

ii) **CMP320**

The Workgroup also note that CMP320 is underway, but the Workgroup is confident there are not interactions between CMP320 and CMP303, as both are standalone proposals.

iii) **CMP213**

WACM2 used evidence from Cigres Papers referred to in CMP213, in particular Cigre Working Group 186. The Workgroup discussed at length CMP213 and its implications on this modification. One Workgroup member stated that they had carried out a review of Cigre papers, and did not find anything therein which would impact some of the CMP303 WACMs in regards to converter costs. The workgroup came to the consensus that CMP213 original stated that converter costs shouldn't be excluded from local circuit charge.

Cigre Working Group 186 (June 2001) undertook analysis, referenced in the CMP213 report, which found that approximately half of the basic cost elements have characteristics, equivalent to AC, and half to DC. Therefore, it was suggested during CMP213, and for CMP303 WACM1, that half the costs of the converter station should be treated in the same way as if it was for an onshore substation. This is found in Annex 14.4 in the CMP213 report.

The workgroup broke down the elements of the converter station costs and these had characteristics similar to that of the substation, around 50%. One Workgroup member disagreed as he didn't interpret the Cigre document in the same way as other Workgroup members, pointing out that Cigre 388 does give an apportionment of AC and DC assets and came up with 50% figure but this was already enshrined in the CUSC.

Some WACMs advocated 50% based on characteristics, whereas some advocated 100%, or case specific proportions based on services provided. It was highlighted that WACM 2 and 3 proposals are based on the services the converter station provides. The proposer of WACM 2 and 3 confirmed that this was correct in regards to his analysis

The Workgroup explored whether any specific analysis was needed to demonstrate that raised WACMs were inline. One Workgroup member concluded that WACM1 was consistent with the 50% treatment, in the context of CMP303 which didn't look at services. It was opined that WACM1 was consistent with CMP213, and WACM2 and WACM3 look at something different.

It was highlighted that a Workgroup consultation response had used the findings of the Cigre reports as an argument against WACM1. It was argued that a conscious decision was made in CMP213 to include 100% of converter costs and that costs being triggered by users should be paid by these users. Some Workgroup members questioned the

respondee's understanding as in the past the Authority had mentioned that they are open to the socialisation of HVDC costs.

Two position papers were provided by a Workgroup member in regards to WACM3, which are available in Annex 9 and 10.

Evaluation the proposed modification in terms of the impact on competition with historical and onshore circuits.

i) The Workgroup initially considered the impact of the proposed modification in terms of the impact on competition with historical and offshore circuits. A workgroup member suggested that CMP303 and alternatives do a case by case calculation of offshore circuits, and because of this, certain elements need to be taken into account. Onshore circuits are treated generically, this is not because of CMP303 but due to an unaddressed baseline defect, and henceforth does not accept this premise.

ii) The same Workgroup member stated that the basic premise of onshore circuit treatment being generic makes this different from offshore, and henceforth not discriminatory. It was highlighted that it would be extremely complicated for the TO and SO to work out on a case by case basis, and hence why offshore is treated differently to onshore, and needs site specific calculation.

It was argued that for the purposes of onshore, bi directionality vs mono is not an issue, neither is pro rata, nor HVDC. The workgroup member stated that the general offshore and onshore are treated differently in 14.15.14 of the CUSC Baseline, and that offshore and onshore are calculated differently. CMP303 does not cause this. Other Workgroup members agreed with this assessment.

iii) The ESO agreed with the Workgroup member that no historical circuits to which CMP303 could be applied currently exist, an opinion which had been voiced by other Workgroup members during the initial stages of the modification.

Existing Codes Provisions and relative costs

The ESO stated that it was their belief that existing code provisions should suffice in terms of relative costs. This was due to that fact that Transmission Owners are not currently party to or bound by the CUSC, and that existing provisions in the System Operator Transmission Owner Code (STC) enables the ESO to request cost data from the TO and any juncture in line with the associated STCPs.

As mentioned previously throughout Section 4 of this document, access to historical data is not possible but there will be the possibility for the provision of data moving forwards. As such, this is captured under the existing legal text within the STC and the associated STCPs.

Conflicts of Interest

In terms of conflicts of interest, the Workgroup believe provisions already exist for this, within the current price control/transmission license approval regime for regulated transmission owners. Where additional or incremental costs are considered in respect of a project, involving a relevant Transmission Owner and Generator that are part of the

same parent group, those additional or incremental costs will be approved by the Authority.

DUoS Offset and Associated Legal Text

The Workgroup discussed the legal text in regards to WACMs which are permutations of WACM4, and hence share legal text. The group noted that the provisions within the legal text allow for offsetting, which may be through DUoS or some other mechanism, to be utilised if considered appropriate by The Authority on a case-by-case basis. The Workgroup acknowledged that there may be other means, outside the CUSC, by which to achieve the same outcome. If those other means were to be used, the Workgroup noted that WACM 4 (or its variants) approach would not be utilised.

5 Workgroup Consultation responses

The CMP303 Workgroup sought the views of CUSC Parties and other interested parties in relation to the issues noted in this document and specifically in response to the questions highlighted in the report and summarised below:

The CMP303 Workgroup Consultation was issued on 21 December 2018 for 15 Working Days, with a closing date of 22 January 2019.

9 responses were received to the standard Workgroup Consultation questions and are detailed in Section 5 table 1 below. Section 5 Tab 2 details the additional workgroup consultation questions asked.

These tables summarise the answers given, unless full detail was required to summarise. The full answers to the questions can be found in Annex 3 of this document.

Section 5 Table 1: Workgroup Consultation Responses Q1-4

Response from	Q1: Do you believe that CMP303 Original proposal or either of the potential options for change better facilitates the Applicable CUSC Objectives?	Q2: Do you support the proposed implementation approach?	Q3: Do you have any other comments?	Q4: Do you wish to raise a Workgroup Consultation Alternative request for the Workgroup to consider?
Daniel Badcock, Peel Energy	.Peel noted that Section 6 of the document set out the applicable non standard objectives. Peel believe that against a), b) and c), but were neutral against d) and e)	.Peel supported the proposed implementation approach, especially with CfD auctions upcoming	-Peel noted the short timescales involved with the modification and raised a concern that the workgroup had not considered benefits of HVAC subsea or HVDC links had not yet been considered	-No alternative raised

James Anderson, Scottish Power	Scottish Power noted their beliefs that objectives a) and c) were better facilitated by CMP303, with d) and e) being neutral.	Scottish Power recognise that the interaction between CMP303 and provision of certainty to developers ahead of the CfD auction in 2019.	No	No
Eleanor Horn, National Grid ESO	<p>NGESO stated that there was a slight improvement on objective a), however the umbrella of facilitating competition was broad. Consumer benefit in more effective competition for island projects is more uncertain, so it may have a negative to negligible benefit for consumers.</p> <p>Under objective b) the ESO pointed out that socialisation of costs across all market participants does not improve cost reflectivity, so assessed CMP303 negative against objective b). The ESO expressed their opinion that CMP303 was neutral against the baseline. Objective d) was seen as non applicable, but against e), the ESO stated that the proposed original may reduce efficiency of the CUSC arrangements should it set a precedent for users picking and choosing exactly what should be in their local circuit tariff.</p>	<p>NGESO stated they believed the implementation approach had not yet fully been developed, as at the time they were waiting on the legal text, so could not support it.</p> <p>NGESO reiterated that the modification is better than baseline but undermines cost reflectivity.</p>	The proposed original suggests that the additional cost (cost for TO choice – cost for user requirement) be removed from the applicable costs that are fed into the transport model to generate local circuit tariff prices. How would the proposer envisage the modification being practically implemented in a situation such as this where the TO doesn't have two clear prices for the different levels of functionality?	No
Michael Ferguson, Simon Redfern, SHEPD plc	SHEPD considered CMP303 original to be better than baseline for objectives a) b) c) and did not make comment against objectives d) and e).	SHEPD agree with the urgency of the implementation timing, driven by the impending CfD auction, and the imperative that developers must have clarity on TNUoS charges ahead of this,	Please see Annex 3 detailing responses for detail.	Please see Annex 3 detailing SHEPD alternative in full.

		noted in section 7.		
Garth Graham, SSE Generation Ltd.	SSE Generation Limited believe that CMP303 original will better facilitate a), b) and c) but neutral against d) and e).	SSE Generation note the proposed implementation approach set out in Section 7 of the Workgroup consultation and we support that proposed approach. We would, in particular, wish to emphasis the imminent date related issue, namely the forthcoming CfD auction (the date for which is set by the Secretary of State). In this regard, it is vital that an Authority decision is given at least ten working days ahead of the auction closing date to allow participants in the auction sufficient time to factor in the Authority decision (in terms of its impact on TNUoS, and local circuit charges in particular) when they are providing prices into that auction.	SSE Generation note the Workgroup deliberations in terms of Potential Alternative 1 and are mindful of the deliberations of the CMP213 Workgroup1 in this areas which identified that certain elements within the DC Converter Station (rather than all the elements of the DC Converter Station) are akin to the onshore AC transmission infrastructure, such as (AC) sub stations, the cost of which is recovered (cost reflectively) on a non-locational basis. For the avoidance of doubt, it is our understand that this is also the intention for Potential Alternative 1 – namely (in addition to the bi-directionality set out in CMP303 Original) that some, but not all, of the DC Converter Station costs (those akin to the onshore AC transmission infrastructure) would be recovered on a non-locational basis, with the balance of the DC Converter Station costs being recovered (in terms of generators) via, in the example of the Scottish islands, the local circuit charge. Based on the CMP213 analysis this suggest, in the context of Potential Alternative 1, “that approximately half of the basic cost	No

			<p>elements of the HVDC converter station have characteristics equivalent to AC and the other half to DC". Therefore, if one assumes that circa half the total cost of a HVDC link consists of the cost of the (two) convertor stations and the remaining half is the cost of the cable(s) then approximately a quarter of the total cost of the HVDC link cost would be</p> <p>recovered on a non-locational basis and the remaining three quarters would be incurred on a locational basis</p>	
Simon Swiatek, Forsa Energy	<p>(a) Yes - the removal of additional costs that are unrelated to the generator's needs will assist generators in market competition.</p> <p>(b) Yes – the proposal means the local circuit charge payable by the generator will be reflective of the costs incurred by the relevant transmission licensee in providing the required export capability (removing any extra costs unrelated to the required export capability).</p> <p>(c) Yes - this proposal will take account of developments in transmission licensees' business such as providing HVDC links to remote island. The proposal will mean that costs unrelated to</p> <p>export capability are not assigned to generator local circuit tariffs.)</p>	Yes. We agree with section 7 of the consultation that the modification would require an authority decision at least a few weeks in advance of the proposed CFD auction. This is required in order to allow generators to review their financial modelling and finalise their auction bids.	No	No
Elaine Hanton, Highlands and Islands Enterprise	We believe that CMP303 improves the baseline CUSC in relation to promoting competition and increasing cost reflectivity whilst having no adverse impacts of significance. In relation to the current treatment of generator	We broadly support the implementation approach and timetable proposed agreeing with the urgent need to establish an outcome ahead	We note the short timelines associated with this work group and have some concerns that there may be other benefits of HVAC subsea or HVDC links	No

	<p>local circuit charges for HVAC subsea cables and HVDC we believe it is almost unarguable that these transmission works provide benefits beyond those required by the generators using them. We therefore agree with CMP303 that costs associated with these additional benefits should be removed and consider that the key issue is in quantifying them. We further note that this latter point is reflective of the discussions during Project TransmiT and CMP213 and of Ofgem's final position at that time in that insufficient quantification was provided at that time as evidence.</p>	<p>of the CfD auctions. Whilst we completely agree with the CMP303 proposal and believe it is correct in identifying the CUSC defect and in proposing to remove costs that are not relevant to the generators, we are concerned at this stage that there appears to be some uncertainty over what the costs relate to and how the costs are calculated. We note that there is a variety of alternatives and many of these are case specific and require a good deal of technical and cost assessment work. Given the potential difficulty in establishing a clear method and answer in the required timescales, we hope that this will be afforded the priority required.</p>	<p>that have not yet been considered. Given the issues around timelines we are comfortable that the working group should progress as is but would seek assurance that further modifications in relation to other benefits could be raised at a later date. We note and welcome the working group's comments and confirmations that CMP303 is applicable on a GB basis even though the current extent of relevant HVAC subsea cables and HVDC is somewhat limited. In this context we note it is important that the original proposal and alternatives are also considered in the wider GB context.</p>	
<p>Aaron Priest, Viking Energy Wind Farm LLP</p>	<p>Viking believe the original proposal is positive against objectives a), b) and c) but neutral in terms of d) and e)</p>	<p>VEWF agrees that the implementation process and date should be compatible with the requirements of the announced May 2019 CfD auction. VEWf agrees that, if the CfD auction is to run fairly and competitively, all bidding plant must be able to properly understand and forecast the local circuit element of their TNUoS charge. Therefore a decision is required by the Authority in time</p>	<p>VEWF wishes to reiterate its belief that there is strong evidence to suggest discriminatory TNUoS charging arrangements for HVDC circuits under the CUSC, as it stands, when compared to the treatment of HVAC circuits. VEWf wishes to reiterate that these arrangements are not properly cost reflective. Discrimination, and arrangements which are not properly cost reflective, would constitute a breach of GBSO licence</p>	<p>No</p>

		<p>for parties to take that decision into account when they participate in that auction.</p>	<p>conditions and need to be addressed and rectified quickly. It is arguable that the forthcoming May 2019 CfD auction's fairness and competitiveness could be called into question unless these anomalies are rectified quickly.</p> <p>The following text is lifted from the EU Renewable Energy Directive (2009/28/EC), which, according to the European Union (Withdrawal) Act 2018 will continue to apply post-Brexit.</p> <p>"3. Member States shall require transmission system operators and distribution system operators to set up and make public their standard rules relating to the bearing and sharing of costs of technical adaptations, such as grid connections and grid reinforcements, improved operation of the grid and rules on the non-discriminatory implementation of the grid codes, which are necessary in order to integrate new producers feeding electricity produced from renewable energy sources into the interconnected grid. Those rules shall be based on objective, transparent and non-discriminatory criteria taking particular account of all the costs and benefits associated with the connection of those producers to the grid and of the particular</p>	
--	--	--	---	--

			<p>circumstances of producers located in peripheral regions and in regions of low population density. Those rules may provide for different types of connection.”</p> <p>“7. Member States shall ensure that the charging of transmission and distribution tariffs does not discriminate against electricity from renewable energy sources, including in particular electricity from renewable energy sources produced in peripheral regions, such as island regions, and in regions of low population density.”</p>	
<p>Paul Mott, EDF Energy</p>	<p>Yes. Regarding (a) (facilitates effective competition in the generation and supply of electricity) – the original allows relevant generators to compete fairly in the market without being handicapped by paying extra costs unrelated to the export of their power. Regarding (b) (.....charges which reflect, as far as is reasonably practicable, costs), the original ensures relevant generators face a cost-reflective local circuit charge, without paying for extra costs unrelated to the export of their power. Regarding (c) (...properly takes account of the developments in transmission licensees’ transmission businesses), the original better meets this, as HVDC island links don’t exist yet, and the original, among other scenarios, covers the case where the TO adds bidirectionality as a function to such a link – so that such a</p>	<p>We agree that CMP303 original proposal, and its WACMs, are all linked to an imminent date related issue; namely the date of the next CFD auctions that some local-circuit-connected generators, both AC and DC connected, will compete in to secure support, which is expected to be held by c. May 2019 (in any event, by or before June 2019). In order to compete in this auction efficiently, this generation plant must be able to forecast the local circuit tariff element of their TNUoS charge (which could be materially impacted if this proposal was or</p>		

	<p>development would be properly taken account of in a fair and cost-reflective manner (d) Compliance with the Electricity Regulation and (e) Promoting efficiency in the implementation and administration of the CUSC arrangements, do not seem relevant. Thus, overall the objectives are better met.</p>	<p>was not approved). Therefore timing must allow for a decision by the Authority (with it to be implemented at the start of next charging year) at least a few weeks ahead of the auction. The timeframe is just adequate.</p>		
--	--	---	--	--

Response from	Q5. Do you consider that any of the Potential alternatives set out in Section 4 have merit? Please provide your rationale.	Q6. Do you consider that any of the Potential alternatives set out in Section 4 do not have merit? Please provide your rationale.	Q7. National Grid ESO have identified a number of potential implications associated with CMP303 which are set out in Annex 3. Do you agree or disagree with this assessment? If so, please explain why
Daniel Badock, Peel Energy	Peel stated that they believe alternatives 1 and 2 have merit. 1 and 1a would have merit but further examples would be needed. 2a was also highlighted as having merit.	No	Analysis was welcomed.

<p>James Anderson, Scottish Power</p>	<p>During the CMP213 development process, the issue of excluding HVDC converter costs from the expansion factor for HVDC circuits was proposed as a potential Alternative. At that time there was little evidence of actual costs or operational experience of HVDC technology. It is now appropriate to re-consider the costs to be included in the calculation of HVDC expansion factors and all of the options outlined in section 4 are worthy of further development and consideration by the CMP303 workgroup.</p>	<p>See answer to question 5</p>	<p>The analysis provided by the ESO in Annexe 3 confirms the assumption that where the total amount recoverable from generators is capped by ER 838/2010 any reduction in the amount recovered through local circuit charges will result in an increase the amount recovered from all generators through the generator residual charge. This position may change under Ofgem's Targeted Charging Review which amongst other items proposes that TNUoS residual charges should only be recovered from "Final Demand" and that the "narrow" interpretation of Connection Charges in Ofgem's decision on CMP261 should be implemented.</p>
<p>Eleanor Horn, National Grid ESO</p>	<p>We believe that the alternatives are within the scope of the defect however we don't feel that we have enough detail to fully establish whether they have merit. Our first thoughts are to raise a concern around the reliance on estimating perceived benefits/costs. The estimating methodologies propose using figures from other schemes. There is a risk that too much of the project cost is socialised. We feel that this seriously undermines the principle of cost reflectivity and will have a negative impact on consumers.</p>	<p>N/A</p>	<p>As the provider of the analysis we believe it to be accurate based on the available data and the agreed assumptions/parameters. As is clarified in the workgroup report the NGESO analysis was produced before we knew the outcome of the TCR and so the outputs will most likely now be different. Greater detail from the TCR will be known by June 2019 and the analysis could be reassessed however this is outside the timescales preferred by the workgroup.</p>

Michael Ferguson, Simon Redfern, SHEPD plc	Please see Annex 3 for further details.	Please see Annex 3 for further details.	Please see Annex 3 for further details.
Garth Graham, SSE Transmission Plc.	Alternative 1 Alternative 2b Alternative 2c Alternative 4b	Alternative 2a Alternative 3 Alternative 4a Alternative 5	We have considered the information contained in Appendix 3 from the ESO. In respect of the potential implications we note that the ESO appears to have undertaken their analysis on the basis of an incorrect assumption as regards CMP303 Original and the Potential Alternatives (of which we focus here on 2(b) and 4(b) as these have merit). It appears, from Appendix 3, that the ESO is assuming that it is better, in terms of cost reflectivity, to recover the costs associated with these changes etc., for Demand; such as with bi-directionality and the distribution saving offset; from Generation TNUoS and not Demand via, for example, DUoS. We do not agree with this central premise of the ESO's analysis. The additional costs of (i) bi-directionality (in CMP303 Original) and then (ii) the re-allocation of the TO costs that are offset by the avoided costs of not building a Distribution link because of the building of a Transmission link (in Potential Alternatives 2(b) and 4(b) – with the Alternative 1 aspects recovered from TNUoS) should be recovered, cost reflectively, from those users who benefit from those aspects, namely Demand via, for example, DUoS rather than TNUoS
Simon Swiatek, Forsa Energy	No		The assessment clearly shows the impact on generation residual for various different reductions in local circuit revenue.

Elaine Hanton, Highlands and Islands Enterprise	Alternatives 1 and 2 have merit in particular. All alternatives have some merit	2a and 4a are less reflective than 2a and 2b	Analysis welcomed. TCR considered
Aaron Priest, Viking Energy Wind Farm LLP	Alternatives 1 and 1a Alternative 2b Alternative 4b	Alternative 2a Alternative 4a	Further detailed impact analysis will be required as the range of options narrows. Current analysis is recognised by all parties as "initial and very high level".
Paul Mott, EDF Energy	Please see response in Annex 3 for further detail	Potential WACM 2b is as WACM2a but island-specific – this has less merit, as this data would be very hard to assess for the western isles. It is unclear if it is practical and proportionate.	ESO have modelled reductions in the local circuit revenues (of certain parties) by 10%, 30% and 60% compared to baseline (no change). There is only an impact on the generation residual tariff. The demand residual tariff is not impacted at all. The generation residual increases by between 10p and 57p from the three synthesised scenarios, becoming less negative. Therefore, the modelling shows that this modification, in reducing the local circuit tariffs for any relevant generators, will increase the generation residual, but with no modelled effect at all on the demand residual (TDR) and hence on demand side TNUoS. We expected this outcome, and are in accord.

6 Workgroup Vote

The Workgroup met on 13 February 2019 and voted on whether the Original would better facilitate the Applicable CUSC Objectives than the baseline and what option was best overall.

The Workgroup voted against the Applicable CUSC Charging Objectives for the Original Proposal and the 9 WACMs.

Vote 1 – does the original or WACMs facilitate the objectives better than the Baseline?

Workgroup Member	Better facilitates ACO (a)	Better facilitates ACO (b)?	Better facilitates ACO (c)?	Better facilitates ACO (d)?	Better facilitates ACO (e)?	Overall (Y/N)
Garth Graham, SSE Generation						
Original	YES	YES	YES	NEUTRAL	NEUTRAL	YES
WACM1	YES	YES	YES	NEUTRAL	NEUTRAL	YES
WACM2	NO	NO	NO	NEUTRAL	NEUTRAL	NO
WACM3	YES	YES	YES	NEUTRAL	NEUTRAL	YES
WACM4	YES	YES	YES	NEUTRAL	NEUTRAL	YES
WACM5	YES	YES	YES	NEUTRAL	NEUTRAL	YES
WACM6	NO	NO	NO	NEUTRAL	NEUTRAL	NO
WACM7	YES	YES	YES	NEUTRAL	NEUTRAL	YES
WACM8	NO	NO	NO	NEUTRAL	NEUTRAL	NO
WACM9	NO	NO	NO	NEUTRAL	NEUTRAL	NO

Voting Statement:

My vote on CMP303 Original and the nine WACMs is based on consideration of the component elements:

- (i) Mono/bidirectional functionality;
- (ii) HVDC Converter Station Costs;
- (iii) Case by Case elements;
- (iv) Distribution Offset; and
- (v) Pro-rata.

In terms of (i) I believe that it is better, in terms of applicable objective (b), to recover any additional

costs of bidirectional functionality from those users that benefit from that functionality especially in the context of the counterfactual, of recovering it from the users of the local circuit, namely generator(s) who only need mono (not bi) directional functionality.

It being better in terms of cost reflectivity (b) it is also better in terms of competition (a) and better in terms of reflecting developments (c); whilst being neutral as to (d) and (e).

In terms of (ii) I believe that it is better, in terms of applicable objective (b), to ensure that the local circuit charges for HVDC transmission assets are applied on a similar, non-discriminatory, basis as non HVDC transmission assets. Analysis by CIGRE (such as it's working group 186) and the CMP213 Workgroup identified "that approximately half of the basic cost elements of the HVDC converter station have characteristics equivalent to AC and the other half to DC". For this reason, I believe that it can be justified to apportion half (but not 100%) of the costs of the HVDC converter stations in a similar way to the onshore treatment.

It being better in terms of cost reflectivity (b) it is also better in terms of competition (a) and better in terms of reflecting developments (c); whilst being neutral as to (d) and (e).

In terms of (iii) I believe that it is marginally better, in terms of applicable objective (b), to ensure that the three elements (reactive power etc., quad boosters and, if applicable, black start) are reflected, as a deduction, in the local circuit charges for HVDC transmission assets.

It being better in terms of cost reflectivity (b) it is also better in terms of competition (a) and better in terms of reflecting developments (c); whilst being neutral as to (d) and (e).

In terms of (iv) I believe that it is better, in terms of applicable objective (b), to ensure that if the Authority determines that an offset / contribution; to take account of the savings to end consumers of not proceeding with an alternative option, such as building a distribution link (where one is needed) because a transmission link can be built instead; is appropriate then Section 14 of the CUSC should include the ability to put the Authority's determination into practical effect as regards TNUoS charges generally, and local circuit charges in particular. This will ensure that charges are better, cost reflectively, than the status quo.

It being better in terms of cost reflectivity (b) it is also better in terms of competition (a) and better in terms of reflecting developments (c); whilst being neutral as to (d) and (e).

Finally, in terms of WACM4 and its variants (WACMs 5, 6 and 7) I note the discussion around a purported interaction with an ongoing SCR. I myself do not see any such interaction with any ongoing SCR.

I observe (1) that no such interaction between WACM4 (and it's variants) and any ongoing SCR has been detailed to the Workgroup; (2) that even if such an interaction did exist, and it were possible for

WACM4 et al to fall within a SCR, that it is possible for the Authority to grant an exemption (as noted in CUSC 8.17.1) by, for example, taking account of the wider benefits to consumers; and (3) if WACM4, or one of its variants, were to be approved by the Authority the purported SCR effect could only arise, at that time, by the Authority acting irrationally – by determining the £M figure, on a case by case basis, in accordance with the proposed legal text (for WACM4 and its variants) in such a way as to undermine the conclusions of its own SCR (which is not something that I think would happen).

In terms of (v) I do not believe that it is better, in terms of applicable objective (b), to pro-rata the distribution effects (noted under (iv) above) based on the requisite capacity (MW). This is because it does not reflect the values or benefits or savings to end consumers from a transmission link, such as in terms of the services provided, of the alternative options; for example, from not building a distribution link (as a transmission link is built instead). This is because the cost of building a distribution link; in terms of onshore connection asset works at both ends, the sub-sea surveys, the sea-bed trenching /back-filling for the cable etc., etc.; would be incurred on a non-capacity (MW) basis. In other words, the cost of building a 60MW distribution link does not (as the evidence in the SHEPD response to the CMP303 Workgroup consultation clearly demonstrates) amount to 10% of the cost of building, say, a 600MW HVDC transmission link. Based on the information available to the Workgroup, it suggests that the actual (cost reflective) figure is circa 60% (~£400M for a distribution link, ~£700M for a transmission link). Therefore, applying a pro-rata basis, of ~10% would not be better in terms of cost reflectivity.

It not being better in terms of cost reflectivity (b) it is also not better in terms of competition (a) and not better in terms of reflecting developments (c); whilst being neutral as to (d) and (e).

Given these detailed reasonings I believe that the CMP303 Original, WACM1, WACM3, WACM4, WACM5 and WACM 7 are better overall when compared to the Baseline; and, that WACM1, WACM3, WACM4, WACM5 and WACM 7 are better overall when compared to CMP303 Original (as they include all the positive attributes of the Original, plus they have additional positive attributes in terms of (i)-(iv)).

I believe, for the reasons noted above, that WACM2, WACM6, WACM8 and WACM9 are, overall, not better than the Baseline; and, are not better than the CMP303 Original.

Workgroup Member	Better facilitates ACO (a)	Better facilitates ACO (b)?	Better facilitates ACO (c)?	Better facilitates ACO (d)?	Better facilitates ACO (e)?	Overall (Y/N)
Simon Swiatek, Forsa Energy						
Original	Yes	Yes	Yes	Neutral	Neutral	Yes
WACM1	Yes	Yes	Yes	Neutral	Neutral	Yes
WACM2	Yes	Yes	Yes	Neutral	Neutral	Yes
WACM3	Yes	Yes	Yes	Neutral	Neutral	Yes

WACM4	No	No	No	Neutral	Neutral	No
WACM5	No	No	No	Neutral	Neutral	No
WACM6	No	No	No	Neutral	Neutral	No
WACM7	No	No	No	Neutral	Neutral	No
WACM8	Yes	Yes	Yes	Neutral	Neutral	Yes
WACM9	Yes	Yes	Yes	Neutral	Neutral	Yes

Voting Statement:

ACO (a) The original proposal and the selected WACMS above allow the removal of additional costs that are unrelated to the generator's needs and will therefore assist generators in market competition.

ACO (b) The original proposal and the selected WACMS means the local circuit charge payable by the generator will be reflective of the costs incurred by the relevant transmission licensee in providing the required export capability (removing any extra costs unrelated to the required export capability).

ACO (c) The original proposal and the selected WACMS will take account of developments in transmission licensees' business such as providing HVDC links to remote island. The proposal will mean that costs unrelated to export capability are not assigned to generator local circuit tariffs.

At this time, we are not convinced that WACM4 (and associated WACMs) will be non-discriminatory to all islands, though we do note the ongoing work being carried out by the proposer.

Workgroup Member	Better facilitates ACO (a)	Better facilitates ACO (b)?	Better facilitates ACO (c)?	Better facilitates ACO (d)?	Better facilitates ACO (e)?	Overall (Y/N)
Aaron Priest, VEFW LLP						
Original	YES	YES	YES	NEUTRAL	NEUTRAL	YES
WACM1	YES	YES	YES	NEUTRAL	NEUTRAL	YES
WACM2	NO	NO	NO	NEUTRAL	NEUTRAL	NO
WACM3	YES	YES	YES	NEUTRAL	NEUTRAL	YES
WACM4	YES	YES	YES	NEUTRAL	NEUTRAL	YES
WACM5	YES	YES	YES	NEUTRAL	NEUTRAL	YES
WACM6	NO	NO	NO	NEUTRAL	NEUTRAL	NO
WACM7	YES	YES	YES	NEUTRAL	NEUTRAL	YES
WACM8	NO	NO	NO	NEUTRAL	NEUTRAL	NO
WACM9	NO	NO	NO	NEUTRAL	NEUTRAL	NO

Voting Statement: I believe all options to be taken forward should include the original. Converter cost recovery needs to be evidence based to ensure applicable cost reflectivity. Any security of supply offset would be approved in principle and ultimately subject to separate determination on process and value by the Authority.

Workgroup Member	Better facilitates ACO (a)	Better facilitates ACO (b)?	Better facilitates ACO (c)?	Better facilitates ACO (d)?	Better facilitates ACO (e)?	Overall (Y/N)
Paul Mott, EDF Energy						
Original	Yes	Yes	Yes	Neutral	Neutral	Yes
WACM1	Yes	Yes	Yes	Neutral	Neutral	Yes
WACM2	Yes	Yes	Yes	Neutral	Neutral	Yes
WACM3	Yes	Yes	Yes	Neutral	Neutral	Yes
WACM4	No	No	Neutral	Neutral	Neutral	No
WACM5	No	No	Neutral	Neutral	Neutral	No
WACM6	No	No	Neutral	Neutral	Neutral	No
WACM7	No	No	Neutral	Neutral	Neutral	No
WACM8	Yes	Yes	Yes	Neutral	Neutral	Yes
WACM9	Yes	Yes	Yes	Neutral	Neutral	Yes

Voting Statement:

Regarding (a) (facilitates effective competition in the generation and supply of electricity) – the original and the WACMS indicated above allow relevant generators to compete fairly in the market without being handicapped by paying extra costs unrelated to the export of their power.

Regarding (b) (.....charges which reflect, as far as is reasonably practicable, costs), the original and the WACMS indicated above ensure relevant generators face a cost-reflective local circuit charge, without paying for extra costs unrelated to the export of their power, or costs which benefit other users and not the connecting generators.

Regarding (c) (...properly takes account of the developments in transmission licensees' transmission businesses), the original and the WACMS indicated above better meet this, as HVDC island links don't exist yet. The original, among other scenarios, covers the case where the TO adds bidirectionality as a function to such a link – so that such a development would be properly taken account of in a fair and cost-reflective manner. The WACMS indicated above in the table also take account of HVDC developments.

(d) Compliance with the Electricity Regulation and (e) Promoting efficiency in the implementation and administration of the CUSC arrangements, do not seem relevant.

Thus, overall the objectives are better met for the WACMS indicated above in the table.

WACM4 and the derivatives that include it have, inter alia, a particular drawback. It is far from clear that the relevant numbers to make this WACM work for all island groups, or any, can be derived to same timeframe, and indeed in time for the critical May CFD auction. This being so, there is a grave risk of inadvertent discrimination, impeding competition even compared to baseline. This renders WACM4 and the derivatives that include it are for this reason unable to effectively take forward cost-reflectivity. They attempt to address developments in transmission licensees' transmission businesses, but do so ineffectively for the above reason.

Workgroup Member	Better facilitates ACO (a)	Better facilitates ACO (b)?	Better facilitates ACO (c)?	Better facilitates ACO (d)?	Better facilitates ACO (e)?	Overall (Y/N)
Nigel Scott, Xero Energy						
Original	Yes	Yes	Yes	Neutral	Neutral	Yes
WACM1	Yes	Yes	Yes	Neutral	Neutral	Yes
WACM2	Yes	Yes	Yes	Neutral	Neutral	Yes
WACM3	Yes	Yes	Yes	Neutral	Neutral	Yes
WACM4	No	No	No	Neutral	Neutral	No
WACM5	No	No	No	Neutral	Neutral	No
WACM6	No	No	No	Neutral	Neutral	No
WACM7	No	No	No	Neutral	Neutral	No
WACM8	Yes	Yes	Yes	Neutral	Neutral	Yes
WACM9	Yes	Yes	Yes	Neutral	Neutral	Yes

Voting Statement:

The WACM broadly break into 2 categories. HVDC related and import (demand) related.

All the HVDC related WACM (1-3) are better than baseline as baseline does not account for the wider system benefits of HVDC and is therefore not as cost reflective as it should be. Of these WACM3 is the most cost reflective but involves the most work and ideally would cede to a simpler WACM as per WACM1 and 2. Notwithstanding this, WACM2 is supported by work undertaken and presented as part of WACM3.

It is not entirely clear how WACM4 fits within CMP303 and this appears to be a separate matter for the proposer (SSE) and regulator. The application of WACM4 appears to be very Shetland specific and related to the historic supply issues on Shetland. Application as proposed to the generator local circuit charging would appear to provide a very large TNUoS discount to Shetland generators with little or no discount for any other island group or applicable case. this therefore appears to be anti-competitive.

It is also noted that SSE is a key stakeholder in the very large 400MW Shetland Viking project. WACM4 appears to be a clear conflict of interest in relation to SSE.

WACM4 also promotes a c. £400 million discount from the capex entered into the generator local circuit charge for Shetland. This means that the capex discount associated with demand is larger than the remaining capex associated with the generators. Given there is 600MW of generation export and about 30-60MW of demand this does not appear cost reflective.

Other concerns exist over WACM4.

As a result of the above, WACM5, 6 and 7 cannot be supported.

WACM8 promotes what appears to be a simple and cost reflective method to deal with demand (import).

WACM9 is satisfactory in combining other WACM.

Workgroup Member	Better facilitates ACO (a)	Better facilitates ACO (b)?	Better facilitates ACO (c)?	Better facilitates ACO (d)?	Better facilitates ACO (e)?	Overall (Y/N)
Sharon Gordon, SHETL						
Original	Y	Y	Y	Neutral	Neutral	Y
WACM1	Y	Y	Y	Neutral	Neutral	Y
WACM2	Y	Y	Y	Neutral	Neutral	Y
WACM3	Y	Y	Y	Neutral	N	Y
WACM4	Y	Y	Y	Neutral	Y	Y
WACM5	Y	Y	Y	Neutral	Y	Y
WACM6	Y	Y	Y	Neutral	Y	Y
WACM7	Y	Y	Y	Neutral	N	Y
WACM8	Y	Y	Y	Neutral	N	Y
WACM9	Y	Y	Y	Neutral	N	Y
Voting Statement: No Statement Given						
Workgroup Member	Better facilitates	Better facilitates	Better facilitates	Better facilitates	Better facilitates	Overall (Y/N)

	ACO (a)	ACO (b)?	ACO (c)?	ACO (d)?	ACO (e)?	
Eleanor Horn – National Grid ESO						
Original	Y	N	Neutral	Neutral	Neutral	Y
WACM1	Y	N	Neutral	Neutral	Neutral	N
WACM2	Y	N	Neutral	Neutral	Neutral	N
WACM3	N	N	Neutral	Neutral	N	N
WACM4	N	N	N	Neutral	N	N
WACM5	N	N	N	Neutral	N	N
WACM6	N	N	N	Neutral	N	N
WACM7	N	N	N	Neutral	N	N
WACM8	N	N	N	Neutral	N	N
WACM9	N	N	N	Neutral	N	N

Voting Statement:

Original

As per our consultation response we expressed a support for the original in better fulfilling ACO (a) by enabling island projects to participate more effectively in the CfD auctions albeit with a small negative impact to consumers. We are satisfied that the potentially large reduction in cost reflectivity is accounted for in the legal text which very clearly deducts costs for additional functionality only when the Relevant Transmission Owner can provide two clear costs to calculate the differential. Therefore, we are supportive of the Original in facilitating the ACO better than Baseline CUSC.

WACM1

Despite WACM1 providing the same competition benefits as the Original we believe in this case that the negative impact on cost reflectivity outweighs the positive impact on competition as it socialises significantly more costs amongst all GB generation users (as the charging methodologies currently stand). Therefore, we are not supportive of WACM1 in facilitating the ACO better than Baseline CUSC.

WACM2

Despite WACM2 providing the same competition benefits as the Original we believe in this case that the negative impact on cost reflectivity outweighs the positive impact on competition as it socialises significantly more costs amongst all GB generation users (as the charging methodologies currently stand). Therefore, we are not supportive of WACM2 in facilitating the ACO better than Baseline CUSC.

WACM3

WACM3 places a much greater burden on the Relevant Transmission Licensee and NGENSO revenue teams to make bespoke calculations on a case by case basis significantly worsening ACO (e). We do not believe there are any benefits to the other ACOs to negate this. We are especially concerned about setting a precedent where users are paid/receive a discount based on the capability of an asset instead of how it is actually used in practice. There are still some outstanding questions on how practicable this WACM is in terms of the data required in the proposed methodology. For all of these reasons we do not support WACM3.

WACM4

Although we are sympathetic to the proposer's intentions here we are reluctant to support this WACM as we are concerned that there has been a lack of transparency in the development of the WACM and therefore industry have not had chance to input into the development process. The draft legal text is very broad and has no provisions for public reporting of the proposed transfers – we feel this does not better facilitate competition. Additionally, as the text currently stands it could be generically applied to a range of third parties and lacks clarity on how a “commensurate reduction” would be calculated.

On the principle we are cautiously supportive of a whole system approach but are wary of taking into account assets that are only potentially to be built which will require many assumptions to be made. We would be concerned about the transparency of these needs cases as the legal text doesn't specify that the Authority must make a ruling on the amount to be transferred on a case by case basis.

WACM4 combines the Original and the “DUoS offset” proposal – we believe there may be scope for double counting of perceived demand benefits here. Consequently, we do not support WACM4.

WACM5

As this WACM is a hybrid of earlier options please see comments on the individual options.

WACM6

As this WACM is a hybrid of earlier options please see comments on the individual options.

WACM7

As this WACM is a hybrid of earlier options please see comments on the individual options.

WACM8

WACM8 proposes an alternative solution to the defect by “pro-rataing” the import potential to the island and the export rating to determine a deduction from the local circuit tariff. We believe this method overstates the benefits provided to demand on the island from a newly built transmission link by taking the peak demand on the island with the potential for double counting and not producing an accurate picture of the actual usage of the link for import. We are especially concerned about setting a precedent where users are paid/receive a discount based on the capability of an asset instead of how it is actually used in practice. There are still some outstanding questions on how practicable this WACM is in terms

of the data required in the proposed methodology. For all of these reasons we do not support WACM8.

WACM9

As this WACM is a hybrid of earlier options please see comments on the individual options.

Vote 2 – Do the WACMs facilitate the objectives better than the Original?

Workgroup Member	Better facilitates ACO (a)	Better facilitates ACO (b)?	Better facilitates ACO (c)?	Better facilitates ACO (d)?	Better facilitates ACO (e)?	Overall (Y/N)
Garth Graham - SSE						
WACM1	YES	YES	YES	NEUTRAL	NEUTRAL	YES
WACM 2	NO	NO	NO	NEUTRAL	NEUTRAL	NO
WACM 3	YES	YES	YES	NEUTRAL	NEUTRAL	YES
WACM 4	YES	YES	YES	NEUTRAL	NEUTRAL	YES
WACM 5	YES	YES	YES	NEUTRAL	NEUTRAL	YES
WACM 6	NO	NO	NO	NEUTRAL	NEUTRAL	NO
WACM 7	YES	YES	YES	NEUTRAL	NEUTRAL	YES
WACM 8	NO	NO	NO	NEUTRAL	NEUTRAL	NO
WACM 9	NO	NO	NO	NEUTRAL	NEUTRAL	NO

Voting Statement: [See my detailed reasoning provided under ‘Vote 1’ above which, for the sake brevity, I do not repeat here.]

Workgroup Member	Better facilitate ACO (a)	Better facilitates ACO (b)?	Better facilitates ACO (c)?	Better facilitates ACO (d)?	Better facilitates ACO (e)?	Overall (Y/N)
Simon Swiatek– Forsa Energy						
WACM1	Yes	Yes	Yes	Neutral	Neutral	Yes
WACM 2	Yes	Yes	Yes	Neutral	Neutral	Yes
WACM 3	Yes	Yes	Yes	Neutral	Neutral	Yes
WACM 4	No	No	No	Neutral	Neutral	No

WACM 5	No	No	No	Neutral	Neutral	No
WACM 6	No	No	No	Neutral	Neutral	No
WACM 7	No	No	No	Neutral	Neutral	No
WACM 8	Yes	Yes	Yes	Neutral	Neutral	Yes
WACM 9	Yes	Yes	Yes	Neutral	Neutral	Yes

Voting Statement:

ACO (a) The original proposal and the selected WACMS above allow the removal of additional costs that are unrelated to the generator's needs and will therefore assist generators in market competition.

ACO (b) The original proposal and the selected WACMS means the local circuit charge payable by the generator will be reflective of the costs incurred by the relevant transmission licensee in providing the required export capability (removing any extra costs unrelated to the required export capability).

ACO (c) The original proposal and the selected WACMS will take account of developments in transmission licensees' business such as providing HVDC links to remote island. The proposal will mean that costs unrelated to export capability are not assigned to generator local circuit tariffs.

At this time, we are not convinced that WACM4 (and associated WACMs) will be non-discriminatory to all islands, though we do note the ongoing work being carried out by the proposer.

Workgroup Member	Better facilitate ACO (a)	Better facilitates ACO (b)?	Better facilitates ACO (c)?	Better facilitates ACO (d)?	Better facilitates ACO (e)?	Overall (Y/N)
Aaron Priest – Viking Energy						
WACM1	YES	YES	YES	NEUTRAL	NEUTRAL	YES
WACM 2	NO	NO	NO	NEUTRAL	NEUTRAL	NO
WACM 3	YES	YES	YES	NEUTRAL	NEUTRAL	YES
WACM 4	YES	YES	YES	NEUTRAL	NEUTRAL	YES
WACM 5	YES	YES	YES	NEUTRAL	NEUTRAL	YES
WACM 6	NO	NO	NO	NEUTRAL	NEUTRAL	NO
WACM 7	YES	YES	YES	NEUTRAL	NEUTRAL	YES
WACM 8	NO	NO	NO	NEUTRAL	NEUTRAL	NO
WACM 9	NO	NO	NO	NEUTRAL	NEUTRAL	NO

Voting Statement:						
Workgroup Member	Better facilitate ACO (a)	Better facilitates ACO (b)?	Better facilitates ACO (c)?	Better facilitates ACO (d)?	Better facilitates ACO (e)?	Overall (Y/N)
Paul Mott – EDF (Proposer)						
WACM 1	Yes	Yes	Yes	Neutral	Neutral	Yes
WACM 2	Yes	Yes	Yes	Neutral	Neutral	Yes
WACM 3	Yes	Yes	Yes	Neutral	Neutral	Yes
WACM 4	No	No	Neutral	Neutral	Neutral	No
WACM 5	No	No	Neutral	Neutral	Neutral	No
WACM 6	No	No	Neutral	Neutral	Neutral	No
WACM 7	No	No	Neutral	Neutral	Neutral	No
WACM 8	Yes	Yes	Yes	Neutral	Neutral	Yes
WACM 9	Yes	Yes	Yes	Neutral	Neutral	Yes
Voting Statement:						
Workgroup Member	Better facilitate ACO (a)	Better facilitates ACO (b)?	Better facilitates ACO (c)?	Better facilitates ACO (d)?	Better facilitates ACO (e)?	Overall (Y/N)
Nigel Scott – Xero Energy						
WACM1	Yes	yes	Yes	<i>neutral</i>	<i>neutral</i>	Yes
WACM 2	yes	yes	Yes	<i>neutral</i>	Yes	Yes
WACM 3	yes	Yes	Yes	<i>neutral</i>	Yes	Yes
WACM 4	yes	yes	Yes	<i>neutral</i>	<i>neutral</i>	Yes
WACM 5	No	No	<i>neutral</i>	<i>neutral</i>	No	No
WACM 6	No	No	<i>neutral</i>	<i>Neutral</i>	No	No
WACM 7	No	No	<i>neutral</i>	<i>Neutral</i>	No	No
WACM 8	No	No	<i>neutral</i>	<i>Neutral</i>	No	No
WACM 9	Yes	Yes	Yes	<i>Neutral</i>	<i>Neutral</i>	Yes

Voting Statement:

The WACMs as identified all promote competition through improved cost reflectivity and are arguably better than the baseline which is focused onto import/demand only.

WACM2 has the added advantage of aligning the HVDC methodology with the normal onshore method which does not include any substation assets. It is supported by work conducted for WACM3.

WACM4 and 5, 6, and 7 are not better than the original for the reasons previously outlined.

WACM8 presents a simple method to replace the original and is better since it reflects the actual use of the HVAC or HVDC link for import purposes not related to the generator export.

Workgroup Member	Better facilitate ACO (a)	Better facilitates ACO (b)?	Better facilitates ACO (c)?	Better facilitates ACO (d)?	Better facilitates ACO (e)?	Overall (Y/N)
Sharon Gordon – SHETL						
WACM1	Y	Y	Y	Y	Y	Y
WACM 2	Y	Y	Y	Y	Y	Y
WACM 3	Y	Y	Y	Y	Y	Y
WACM 4	Y	Y	Y	Y	Y	Y
WACM 5	Y	Y	Y	Y	Y	Y
WACM 6	Y	Y	Y	Y	Y	Y
WACM 7	Y	Y	Y	Y	Y	Y
WACM 8	Y	Y	Y	Y	Y	Y
WACM 9	Y	Y	Y	Y	Y	Y

Voting Statement:

Workgroup Member	Better facilitate ACO (a)	Better facilitates ACO (b)?	Better facilitates ACO (c)?	Better facilitates ACO (d)?	Better facilitates ACO (e)?	Overall (Y/N)
Eleanor Horne – National Grid ESO						
WACM1	N	N	Neutral	Neutral	Neutral	N
WACM 2	N	N	Neutral	Neutral	Neutral	N

WACM 3	<i>N</i>	<i>N</i>	<i>Neutral</i>	<i>Neutral</i>	<i>N</i>	<i>N</i>
WACM 4	<i>N</i>	<i>N</i>	<i>N</i>	<i>Neutral</i>	<i>N</i>	<i>N</i>
WACM 5	<i>N</i>	<i>N</i>	<i>N</i>	<i>Neutral</i>	<i>N</i>	<i>N</i>
WACM 6	<i>N</i>	<i>N</i>	<i>N</i>	<i>Neutral</i>	<i>N</i>	<i>N</i>
WACM 7	<i>N</i>	<i>N</i>	<i>N</i>	<i>Neutral</i>	<i>N</i>	<i>N</i>
WACM 8	<i>N</i>	<i>N</i>	<i>N</i>	<i>Neutral</i>	<i>N</i>	<i>N</i>
WACM 9	<i>N</i>	<i>N</i>	<i>N</i>	<i>Neutral</i>	<i>N</i>	<i>N</i>

Voting Statement:

As explained in our voting statement for part 1 we do not feel that any of the WACMs are better than the Original.

Vote 3 – Which option is the best?

Workgroup Member	BEST Option?
Paul Mott – EDF (Proposer)	WACM 8
Garth Graham - SSE	WACM 5
Eleanor Horne – National Grid ESO	The Original
Nigel Scott – Xero Energy	WACM9 as it addresses both HVDC wider system benefits and import requirement benefits.
Aaron Priest – Viking Energy	WACM 5
Simon Swiatek– Forsa Energy	WACM 8
Sharon Gordon – SHETL	WACM 5

The Workgroup voted against the Applicable CUSC Objectives for the Original Proposal and nine WACMs. Three Workgroup members concluded that WACM 5 was the best option. Two Workgroup members believed that WACM 8 was the best. WACM 9 and the Original both received one vote each.

7 CMP303: Relevant Objectives

Impact of the modification on the Applicable CUSC Objectives (Charging):

Relevant Objective	Identified impact
(a) That compliance with the use of system charging methodology facilitates effective competition in the generation and supply of electricity and (so far as is consistent therewith) facilitates competition in the sale, distribution and purchase of electricity;	Positive – allows relevant generators to compete fairly in the market without being handicapped by paying extra costs unrelated to the export of their power
(b) That compliance with the use of system charging methodology results in charges which reflect, as far as is reasonably practicable, the costs (excluding any payments between transmission licensees which are made under and accordance with the STC) incurred by transmission licensees in their transmission businesses and which are compatible with standard licence condition C26 requirements of a connect and manage connection);	Positive – ensures relevant generators face a cost-reflective local circuit charge, without paying for <u>extra</u> costs unrelated to the export of their power
(c) That, so far as is consistent with sub-paragraphs (a) and (b), the use of system charging methodology, as far as is reasonably practicable, properly takes account of the developments in transmission licensees' transmission businesses;	Positive – HVDC island links don't exist yet, this mod among other scenarios covers the case where the TO adds bidirectionality as a function to such a link. This mod brings the CUSC up to date and ensures any such developments in relation to local circuit charges are properly taken account of in a fair and cost-reflective manner
(d) Compliance with the Electricity Regulation and any relevant legally binding decision of the European Commission and/or the Agency. These are defined within the National Grid Electricity Transmission plc Licence under Standard Condition C10, paragraph 1*; and	Not Relevant
(e) Promoting efficiency in the implementation and administration of the CUSC arrangements.	Not Relevant

8 Implementation

Proposer's initial view of Implementation Date was linked to the 2019 CfD Auction and is set out below:

This CMP303 proposal is linked to an imminent date related issue; namely the date of the next CfD auctions that some local-circuit-connected generators, both AC and DC connected, will compete in to secure support, which is expected to be held in May 2019 or shortly after (in any event, by or before June 2019). In order to compete in this auction efficiently, this generation plant must be able to forecast the local circuit tariff element of their TNUoS charge (which could be materially impacted if this proposal was or was not approved). Therefore, this CMP303 modification would require a decision by the Authority (with it to be implemented at the start of next charging year) at least one week ahead of the earliest conceivable auction tender submission deadline.

However, the CfD auction has now been held but proposed implementation date is still 1 April 2020.

9 First Code Administrator Consultation Responses – Summary

The Code Administrator Consultation was issued on 26 February 2019 for 20 Working days, with a close date of 19 March 2019. Seven responses were received to the Code Administrator Consultation and are detailed in the table below.

The full responses to the First Code Administrator Consultation can be found in Annex 8 of this report.

Respondent	Do you believe that CMP303 better facilitates the CUSC Applicable objectives?	Do you support the proposed implementation approach?	Do you have any other comments?
Paul Jones, Uniper UK Ltd	<p>It is not clear that a case has been made that this proposal would result in comparable treatment of subsea cables circuits compared with onshore equivalents in the context of the stated defect (ie that a circuit may have additional functionality over and above that needed for the specific generator concerned). No consideration is given under the present methodology as to why a certain technology and voltage level has been chosen for a specific circuit onshore either. Decisions are highly likely to have been for purposes other than just supporting the generation which uses the circuit, particularly as many of the routes will have been constructed a long time before many of the generators were built or even planned. The ICRP methodology does not look at those historic decisions and simply assesses whether an additional 1MW of generation would increase or decrease usage of the relevant circuits. It then allocates a cost or benefit based on that increased or decreased usage and the MWkm cost of the specific circuit type. Therefore, it is not clear that there is a defect to address.</p> <p>Arguably, making the changes proposed will reduce cost reflectivity as the circuit charges will not reflect the true cost of the assets</p>	No, we do not support implementation of the modification.	No thank you.

	<p>concerned, particularly compared with the treatment of onshore assets. Reduction in cost reflectivity will result in inefficient locational decisions being made and undermine competition in the generation market.</p> <p>We certainly do not support the use of this modification to reopen the issue of whether or not converter stations should be included in the circuit charges for those assets. Dilution of the signal in relation to the cost of converter stations in this manner goes over and above the scope of the original defect, which simply refers to whether circuits were designed with additional functionality to that needed just to support the generation using them.</p> <p>A conscious decision was made by the Authority when approving the chosen solution for CMP213 to include 100 percent of these costs. Indeed, the Authority believed that the inclusion of these costs would be more cost reflective than not doing so and stated its view that <i>“the investment in the HVDC converter stations (including the specific design elements) for bootstrap and island links arise specifically to serve those links and provide the required transmission capacity. Furthermore, our general view is that it is appropriate that costs that are being triggered by users are paid for by those users, to promote cost reflectivity</i></p>		
--	--	--	--

	<p><i>and ensure efficient decisions.” (Ofgem’s CMP213 impact assessment Aug 2013)</i></p> <p>We note that the arguments for the exclusion of costs are largely based on analysis which was presented by some CMP213 workgroup members when also advocating such an approach. It should be noted that this view was only supported by a slight majority of CMP213 workgroup members. Out of the 20 options voted on which included some form of exclusion of converter costs, only 4 options received supporting votes from a majority of workgroup members. In these instances 8 out of 15 work group members supported these options (ie 53% of the total vote). It would be reasonable to conclude that the vote was split in these cases.</p> <p>Due to the reduction in cost reflectivity that this modification would represent and the detrimental effect this would have on competition, we consider that objectives a) and b) would be undermined if it were to be implemented.</p>		
Paul Mott, EDF Energy	Yes. Regarding (a) (<i>facilitates effective competition in the generation and supply of electricity</i>) – the original, and all WACMs except 4 to 7, have the potential to allow relevant generators to compete fairly in the	We agree that CMP303 original proposal, and its WACMs, are all linked to an imminent date related issue; namely the date of the next CFD auctions that some local-circuit-connected generators, both AC and DC connected, will compete in to	We would comment that the original, and WACMs 8, 1, 2, and 3, are relatively simpler and easier to administer, and the former two are applicable to a range of local circuits/types, wherever they are relevant.

	<p>market without being handicapped by paying extra costs unrelated to the export of their power. The concept that underlies WACMs 4 to 7 is being considered separately in the needs case process, and is referred to in the needs case minded-to Ofgem consultation documents issued this morning for two of the island links, <i>“SHEPD has submitted a proposal to contribute, on behalf of demand consumers, towards the cost of transmission links to reflect the avoided cost of replacing existing back-up generation on the Isles in future. We are considering the SHEPD proposal and we will shortly be publishing a separate document outlining our views”</i> – we take it that this separate document will be a consultation. CUSC says at 14.15.75 that AC cable and HVDC circuit expansion factors are to be calculated on a case by case basis using actual project costs, which presumably might be interpreted as altered (reduced) actual project costs, should Ofgem’s view of SHEPD’s proposals be positive.</p> <p>Regarding (b) (<i>.....charges which reflect, as far as is reasonably practicable, costs</i>), the original and WACMs allow relevant generators face a cost-reflective local circuit charge, without paying for extra costs unrelated to the export of their power. WACM4,5,6,7 however are neutral here, as it is not clear if they are</p>	<p>secure support, which is expected to be held by May 2019. In order to compete in this auction efficiently, this generation plant must be able to forecast the local circuit tariff element of their TNUoS charge (which could be materially impacted if this proposal was or was not approved). Therefore timing must allow for a decision by the Authority (with it to be implemented at the start of next charging year) at least a few weeks ahead of the auction. The timeframe is just adequate.</p>	
--	--	--	--

	<p>workable or relevant.</p> <p>Regarding (c) (...<i>properly takes account of the developments in transmission licensees' transmission businesses</i>), the original and the variants except 4 to 7 inclusive better meet this, as HVDC island links don't exist yet, and the original, and others, cover these new links – so that such a development would be properly taken account of in a fair and cost-reflective manner. The original is not limited to HVDC though, and neither is the demand pro-rata WACM.</p> <p>(d) Compliance with the Electricity Regulation and (e) Promoting efficiency in the implementation and administration of the CUSC arrangements, do not seem relevant.</p> <p>Thus, overall the objectives are better met by the original and all WACMs except 4 to 7 inclusive, which do not better meet the objectives than original, or than baseline. WACM4 and the derivatives that include it (WACM 5, WACM 6, and WACM 7) have a drawback that it is not clear that the relevant numbers to make this WACM work for all island groups, or any, can be derived to same timeframe, and indeed in time for the critical May CFD auction. Such a timing discrepancy could impede competition, though we note the ongoing work being carried out by Ofgem.</p>		
--	---	--	--

	<p>This risk could render WACM4 and the derivatives that include it, unable to effectively take forward cost-reflectivity. They attempt to address developments in transmission licensees' transmission businesses, but do so ineffectively for the above reason.</p>		
<p>Daniel Badcock, Peel Energy</p>	<p>We agree with the view that the proposal has a positive impact on CUSC objectives, a, b and c and is not relevant to objectives d and e.</p> <p>We consider that the CMP303 proposal improves the baseline CUSC in relation to promoting competition and increasing cost reflectivity whilst having no adverse impacts of significance. We do not believe the existing generator local circuit charging methodology as relates to HVAC subsea cables and HVDC reflects the wider transmission system benefits that are accrued by such works and are not required by the generators currently being asked to pay for them. We believe CMP303 correctly identifies this defect and is correct in examining solutions to it.</p> <p>In relation to the current treatment of generator local circuit charges for HVAC subsea cables and HVDC we believe the CUSC is in defect by not recognising and accounting for the benefits accrued and not required by the generators using them. We therefore agree</p>	<p>We support the implementation approach and timetable proposed, agreeing with the urgent need to establish an outcome ahead of the CfD auctions. The issue of charging is critical to the economics of our projects and other projects on the islands and it is virtually impossible to prepare a competent and competitive CfD bid without a decision on CMP303.</p> <p>Our main concern with the CMP303 process is that it will be difficult to establish a clear answer in the proposed timescales.</p>	<p>We note the short timelines associated with this workgroup and have some concerns that there may be other benefits of HVAC subsea or HVDC links that have not yet been considered. Given the issues around timelines we are comfortable that the workgroup should progress as is but would seek assurance that further modifications in relation to other benefits could be raised at a later date.</p>

	<p>with CMP303 that costs associated with these additional benefits should be removed. We further note that these issues were debated during Project TransmiT and CMP213 but were not addressed at that time, Ofgem directing industry to address them at a later and more appropriate time which we consider is now.</p>		
<p>Garth Graham, SSE Generation Ltd</p>	<p>We believe that CMP303 Original along with WACM1, WACM3 WACM4, WACM5 and WACM7 will ensure that the use of system charging methodology better facilitates effective competition. This is because the individual elements of each of the proposals; either as ‘stand-alone’ or in ‘combination’; ensure that the use of system charges are more cost reflective and as such this is better in terms of facilitating effective competition.</p> <p>We believe that WACM2, WACM6, WACM8 and WACM9 do not better facilitate effective competition.</p> <p>(b) That compliance with the use of system charging methodology results in charges which reflect, as far as is reasonably practicable, the costs (excluding any payments between transmission licensees which are made under and accordance with the STC) incurred by transmission licensees in their transmission businesses and which</p>	<p>We do support the proposed implementation approach as set out in Section 8 of the consultation document.</p> <p>We would, in particular, wish to re-emphasise the point we (and many other respondents to the Workgroup Consultation) made previously around the time criticality of a decision on CMP303 ahead of the forthcoming auction (the date for which has been set by the Secretary of State and not by any potential auction participant) as the decision, on CMP303, will have a materially important effect on auction participants that arise “<i>in particular [with] electricity from renewable energy sources produced in peripheral regions, such as island regions, and in regions of low population density</i>”, namely from Shetland and the Western Isles.</p>	<p>We note that Ofgem has today (19th March 2019) issued a consultation, which can be found at:</p> <p>https://www.ofgem.gov.uk/publications-and-updates/shetland-transmission-project-consultation-final-needs-case-and-delivery-model</p> <p>For the avoidance of doubt we have not been able to fully review or consider that Ofgem consultation document today or take it into account when preparing this response to the CMP303 consultation.</p> <p>We have no additional comments at this time.</p>

	<p>are compatible with standard licence condition C26 requirements of a connect and manage connection);</p> <p>We believe that CMP303 Original along with WACM1, WACM3 WACM4, WACM5 and WACM7 will ensure that the use of system charging methodology is better in terms of cost reflectivity. This is because the individual cost elements of each of the proposals; either as 'stand-alone' or in 'combination'; will be charged, as appropriate, to the users that gave rise to those costs, thus ensuring that the use of system charges are more cost reflective.</p> <p>Thus, the Original, with its application of the additional costs of bi-directional (compared to mono-directional) to the users who give rise to those costs, is more cost reflective than the current Baseline CUSC.</p> <p>WACM1 includes the Original solution but also incorporates the charging of half the costs of the HVDC convertor station element in a similar way to the equivalent HVAC transmission system element. The 50% figure has been sourced from an internationally recognised centre of expertise on the topic (namely CIGRE). Therefore, this WACM1 approach ensures that users who give rise to the convertor stations costs are charged accordingly, which is more cost reflective than</p>		
--	--	--	--

	<p>the current Baseline CUSC.</p> <p>WACM3 includes the Original solution but also incorporates the identification of additional functionality of HVDC links which are unrelated to the needs associated with generation and charges the costs associated with that additional functionality appropriately. Therefore, this WACM3 approach ensures that users who give rise to the additional functionality costs are charged accordingly, which is more cost reflective than the current Baseline CUSC.</p> <p>WACM4 includes the Original solution but also incorporates ability for the identification, by the Authority, of additional benefits of (transmission) HVDC links when compared with an equivalent (distribution) link, if appropriate, and thus provides a cost reflective offset to be applied. Therefore, this WACM4 approach ensures that users of the transmission system are charged appropriately, which is more cost reflective than the current Baseline CUSC.</p> <p>WACM5 is a combination of WACM1 and WACM4 and as such it incorporates all the additional cost reflective benefits that these two 'stand-alone' proposals have in terms of</p>		
--	---	--	--

	<p>converter station costs and an (Authority determined) appropriate offset associated with the avoided costs for a distribution link. Therefore, this WACM5 approach ensures that users of the transmission system are charged appropriately, which is more cost reflective than the current Baseline CUSC.</p> <p>WACM7 is a combination of WACM3 and WACM4 and as such it incorporates all the additional cost reflective benefits that these two 'stand-alone' proposals have in terms of identifying additional functionality for HVDC links and an (Authority determined) appropriate offset associated with the avoided costs for a distribution link. Therefore, this WACM7 approach ensures that users of the transmission system are charged appropriately, which is more cost reflective than the current Baseline CUSC.</p> <p>We believe that WACM2, WACM6, WACM8 and WACM9 do not better facilitate cost reflective charging for use of system charges.</p> <p>(c)That, so far as is consistent with sub-paragraphs (a) and (b), the use of system charging methodology, as far as is reasonably practicable, properly takes account of the developments in</p>		
--	---	--	--

	<p>transmission licensees' transmission businesses;</p> <p>We believe that CMP303 Original along with WACM1, WACM3 WACM4, WACM5 and WACM7 will ensure that the use of system charging methodology as far as is reasonably practicable properly takes account of developments in the transmission business; as regards the development of HVDC links in terms of demand and generation locations; within the transmission licensees area of operations.</p> <p>We believe that WACM2, WACM6, WACM8 and WACM9 do not better ensure that the use of system charging methodology as far as is reasonably practicable properly takes account of developments in the transmission business.</p> <p>(d) Compliance with the Electricity Regulation and any relevant legally binding decision of the European Commission and/or the Agency. These are defined within the National Grid Electricity Transmission plc Licence under Standard Condition C10, paragraph 1*; and</p> <p>We believe that CMP303 Original along with WACM1, WACM3 WACM4, WACM5 and WACM7 will achieve a use of system charging methodology for GB that is in compliance with</p>		
--	---	--	--

	<p>EU law, in terms of the legally binding EU Renewable Energy Directive (2009/28/EC)⁷.</p> <p>In this regard, it is important to recognise Recital (63), which states that:</p> <p><i>“Electricity producers who want to exploit the potential of energy from renewable sources in the peripheral regions of the Community, in particular in island regions and regions of low population density, should, whenever feasible, benefit from reasonable connection costs in order to ensure that they are not unfairly disadvantaged in comparison with producers situated in more central, more industrialised and more densely populated areas.”</i></p> <p>This is a situation that self-evidently exists for the costs arising from the proposed Shetland and Western Isles HVDC links (which are both island regions and regions of low population density).</p> <p>Therefore, potential auction participation from</p>		
--	--	--	--

⁷ <https://eur-lex.europa.eu/legal-content/EN/TXT/PDF/?uri=CELEX:32009L0028&from=EN>

	<p>renewable energy sources from those locations will be achieved to a greater extent (than the current CUSC Baseline) by CMP303 Original along with WACM1, WACM3 WACM4, WACM5 and WACM7 which, in turn, demonstrates compliance with EU law.</p> <p>Furthermore, Article 16 of the Directive sets out, in the following terms, that:</p> <p>(i) “[Article 16(7)] <i>Member States shall ensure that the charging of transmission and distribution tariffs does not discriminate against electricity from renewable energy sources, in particular electricity from renewable energy sources produced in peripheral regions, such as island regions, and in regions of low population density</i>” (a situation that exists for the proposed Shetland and Western Isles HVDC links) and;</p> <p>(ii) “[Article 16(3)] <i>standard rules relating to the bearing and sharing of costs of technical adaptations, such as grid connections and grid reinforcements...[and that] Those rules shall be based on objective, transparent and non-discriminatory criteria taking particular account of all the costs and benefits associated with the connection of those producers to the grid and of the particular circumstances of producers</i></p>		
--	---	--	--

	<p><i>located in peripheral regions and in regions of low population density.” (a situation that exists for the proposed Shetland and Western Isles HVDC links).</i></p> <p>(e) Promoting efficiency in the implementation and administration of the CUSC arrangements.</p> <p>We believe that the Original and all nine WACMs are neutral in terms of better achieving this applicable objective.</p>		
<p>Simon Swiatek, Forsa Energy</p>	<p>[with the exception of WACMs 4, 5, 6 and 7]:</p> <p>(a) Yes - the removal of additional costs that are unrelated to the generator’s needs will assist generators in market competition.</p> <p>(b) Yes – the proposal means the local circuit charge payable by the generator will be reflective of the costs incurred by the relevant transmission licensee in providing the required export capability (removing any extra costs unrelated to the required export capability).</p> <p>(c) Yes - this proposal will take account of developments in transmission licensees’ business such as providing HVDC links to remote island. The proposal will mean that costs unrelated to export capability are not</p>	<p>Yes. We agree with section 7 of the consultation that the modification would require an authority decision at least a few weeks in advance of the proposed CFD auction. This is required in order to allow generators to review their financial modelling and finalise their auction bids.</p>	<p>s per our voting statement, at this time we are not convinced that WACM 4 (and associated WACMs 5, 6 and 7) will be nondiscriminatory to all islands, though we do note the ongoing work being carried out by the proposer.</p>

	<p>assigned to generator local circuit tariffs. We are supportive of the original and WACMs 1 2, 3, 8 and 9 as shown in our voting statement. These WACMs provide various degrees of assistance in meeting the CUSC objectives. We note in particular that the proposal to remove converter costs (as seen in WACMs 1, 2, 3 and 9) reflects some of the ideas developed previously as part of CMP213. WACM 8 offers a straightforward methodology for reflecting the level of demand import. WACM 9 takes account of the additional benefits provided by converters (by combining WACM 3 and WACM 8).</p>		
<p>Michael Ferguson/ Simon Redfern, Scottish Hydro Electric Power Distribution plc</p>	<p>We set out in our previous response that we consider that charging for HVDC links should be cost reflective, with potential for customer / DSO / NGENSO / other contributions towards costs, or otherwise allocations of those costs to those consumers who benefit, where justified. We consider that this arrangement better enables objective (a) in more effectively facilitating competition in the generation and supply of electricity.</p> <p>The CMP 303 original and alternative proposals <i>in general</i> better facilitate objective (b) than the baseline <i>to the extent that</i> the charges continue to reflect the costs incurred by transmission licensees, and lead to costs being shared more equitably among relevant parties who benefit from shared use of a given asset. However, we don't believe that the proposals adequately bear a whole</p>	<p>Again, we agree with the urgency of the implementation timing, driven by the impending CfD auction, and the imperative that developers must have clarity on TNUoS charges ahead of this – there is a consensus on this point among respondents.</p> <p>We consider that the legal text proposed for WACM 4 looks sensible as a starting point, but would strongly suggest that it is further refined by a solicitor with NGENSO, Ofgem and relevant stakeholders in order to ensure it is fully fit for purpose. This may include adding definitions (e.g. for “functionality”) and taking into account Ofgem’s consultation and determination on SHEPD’s</p>	<p>We would like to provide clarification on several points in relation to our workstream, and how this has been translated into WACM 4 (5, 6), leading to incorrect assumptions made by stakeholders which have been reflected in the consultation document.</p> <p>Is a DNO offset (per WACM4 and associated WACMs) discriminatory if different contribution values are applied across the different Scottish Islands? SHEPD understands the sensitivity to this issue. SHEPD’s methodology is based on an assessment of distribution system need, and the benefits / value to the system that a transmission link would bring. The cost of the “next-best alternative” is also relevant, in order to provide context in terms of how much a party would have to pay for goods or</p>

	<p>system future in mind in their consideration of this defect.</p> <p>The CMP 303 proposals identify two broad principles for achieving cost-reflectivity: i) the identification and carve-out of relevant transmission asset / equipment costs such as converter and bidirectionality costs from TNUoS charges, where it is determined that these assets are not required, or are not required in entirety, by generators; and ii) the application of a value for the provision of supply / services from an HVDC system such as “making supply” to an island distribution system, also applied to reduce TNUoS charges.</p> <p>We note that most of the alternatives focus on carving out the cost of additional functionality. This is reasonable, and moves towards cost-reflectivity, but does not go far enough in accommodating the concept of value to wider users in meeting need, as envisaged under whole system principles, which should always be considered in the context of the cost of alternative ways by which that need could be met. This is a forward-looking approach which ensures better readiness with future whole system proposals.</p> <p>The original recommended proposal of CMP 303 identifies the requirement to carve out “extra costs” of “additional functionality” which are “unrelated from the generators needs” from the costs borne by the generators who have requested associated transmission links</p>	<p>Recommendation. SHEPD would be very happy to participate in such a working group for this purpose. It could also be sensible to develop a working document which sits alongside the CUSC to provide more detailed commentary and interpretation on its implementation.</p>	<p>services in the absence of the relevant transmission link solution, and how to determine what is best value. (For example, as noted in SHEPD’s response to the Stage 2 consultation, the next-best alternative cost SHEPD has identified to provide the same services as could be provided by the transmission link is c.£400m. Therefore there is a significant level of cost which would be avoided in pursuing a whole system solution.) There are inevitably and unarguably different levels of need and, hence, benefit and value of transmission solutions to different groups of distribution consumers.</p> <p>Several of the WACMs apply this principle:</p> <ul style="list-style-type: none"> • WACM 8 proposes a calculation based on the <i>specific</i> share of use of the link for import to distribution consumers, “<i>calculated using the import / generation export ratio. The import shall be calculated based on the maximum anticipated import needs</i>”.³ • WACM 3 proposes a case-by-case assessment of the “additional functionality” in terms of ancillary services to the wider network (reactive power, voltage control etc).⁴
--	--	---	--

	<p>(item i) above). It is proposed that costs relating to the function of bidirectionality are removed at a minimum. We agree with cost-sharing, cost-reflective charging in principle, and that a customer should not be faced with undue costs which are unrelated to the service it requires, and it is for the TO, NGENSO, generators and Ofgem to determine specific arrangements. We consider that the original and each of the revised WACMs have some merit in seeking to align TNUoS charges with this principle. However we would note that WACMs which propose cost carve-outs risk causing discriminatory effects if the identification of relevant assets / services is not managed carefully to avoid mis-allocation of costs to the various consumer groups. The involvement of the DSO / DNO or other relevant consumer at this stage in order to confirm need / benefit / value could, again, mitigate this issue.</p> <p>With regards to item ii) above (which it may be appropriate to apply in addition to i), as proposed in various WACMs) where it is established that a third party may benefit from an HVDC system, we recommend that it is for the relevant customer (e.g. DSO / NGENSO) to determine its need, and to make a valuation of the relevant assets / services which would be used by / of benefit to those customers in meeting that need. There should also be a correct allocation of cost, applied towards those customers. We believe this better aligns with both cost-reflectivity and whole system objectives, which are envisaged to see “network</p>		<ul style="list-style-type: none"> WACMs 1 and 2 reflect on project-specific converter cost deductions. These methodologies correctly identify that the costs of, need for and value of an asset / benefit / service vary from situation to situation, and that the impact on TNUoS charged in different situations is simply a by-product of this assessment. <p>SHEPD would be positively discriminating, and acting outside of its licence obligations, if a contribution was proposed which was disproportionate to the need, value and benefit to its consumers. We note that the methodology and value have been shared with Ofgem and other stakeholders, and will be consulted upon shortly.</p> <p>We would note again that WACMs which propose cost carve-outs risk causing discriminatory effects if the identification of relevant assets / services is not managed carefully, to avoid mis-allocation of costs to consumer groups. The involvement of the DSO / DNO or other relevant consumer at this stage in order to confirm need / benefit / value could, again, mitigate this issue.</p> <p><u>2. Does the contribution methodology apply only to the Shetland scenario?</u></p>
--	---	--	--

	<p>operators...identify and pursue solutions that can benefit multiple parties across the system”, with “...Parties contributing efficient costs to reflect the benefits they receive in delivering their obligations and outputs”.¹</p> <p>We note the position reflected in the consultation document that,</p> <p><i>“Whilst the Workgroup found some merit in the alternative request provided by SHEPD, this was not taken forwards by the Workgroup in the form proposed. During Workgroup 5, the Workgroup contacted SHEPD to discuss the proposal further. After the discussions, it was decided that the aspects of the alternative request should to be considered as a formal WACM (it subsequently became WACM4– see below for further details).”²</i></p> <p>We reiterate our view that our alternative approach should be reflected in any CMP303 proposal taken forward to implementation, in order to provide that the benefit or value of an asset and / or services to distribution customers / users is taken into account. Doing so would take proper account of specific need and, following whole system principles, would be more likely to result in a cost efficient / cost reflective outcome. We maintain the recommendation that CMP303 is modified to incorporate this process of engagement with, and determination of need by, relevant parties / customers; and that any CUSC modification taken forward, including definitions, is drafted such that it can accommodate the effect of an</p>		<p>No. We have provided Ofgem with contribution methodologies and values for Shetland, the Western Isles and Orkney. Naturally, these values vary in each situation, reflecting on the level of need, and value / benefits which a transmission link would bring, taking into account any existing infrastructure in these locations.</p> <p><u>3. Will contribution values for all islands be available in the required timeframes?</u></p> <p>SHEPD has been working on its contribution methodology since the beginning of 2018. We submitted our formal Recommendation to Ofgem in November 2018, further to engagement with them through that year.</p> <p>We have provided Ofgem with contribution methodologies and values for Shetland, the Western Isles and Orkney. SHEPD’s ability to make the island contributions is subject to relevant regulatory approvals, including on the methodology, values, and cost recovery arrangements, where relevant.</p> <p>Our Recommendation aligns with the timeframe for CMP 303, in that we have set out that a decision by Ofgem is required by May 2019 in order for generators to progress with their CfD bidding strategies with certainty of the related</p>
--	---	--	---

<p>offset contribution made by a DSO / DNO on behalf of its consumers, where an efficient whole system arrangement has been identified and the relevant methodology for / value of a contribution has been agreed with Ofgem.</p> <p>We consider that modifications / clarifications to the CMP 303 proposals taken forward to this effect would more closely align with whole system principles and would better facilitate objective</p> <p>(c).</p> <p>As noted in our original response, SHEPD has been developing proposals for an enduring solution for Shetland over the past several years, in the context of its distribution licence obligation. SHEPD has over the past year carried out detailed analysis and has developed comprehensive methodologies with independent industry consultants which i) identify island distribution system need, ii) identify and value avoided cost benchmarks, iii) value services from a transmission link to a distribution system and iv) identify how a contribution made by the DSO for the benefit of distribution consumers would be paid for by those consumers. SHEPD has also progressed proposals, with BEIS and Ofgem, around how relevant costs would be recovered from distribution or GB customers.</p> <p>It is expected that Ofgem will consult on SHEPD's recommendation and its own</p>		<p>TNUoS impact. Ofgem has confirmed its ability to make a determination on our Recommendation in this timeframe.</p> <p><u>4. Has WACM 4 / the Shetland DSO contribution workstream been developed with Ofgem and stakeholder engagement?</u></p> <p>Yes. The DSO offset principle within WACM 4 was included in some form in Alternative 2 included within the Stage 02 Workgroup Consultation proposal⁵, and has been refined in response to SHEPD's feedback to that document. The alternative proposals raised in relation to CMP 303 have been considered by the Working Group, including Ofgem and NGENSO, and the public through consultation. As noted above, SHEPD's proposals have been shared with Ofgem since the beginning of 2018, and other stakeholders at relevant points in time in later 2018 and early 2019. Ofgem has reviewed the detail of our methodologies and assumptions. The other stakeholders we have shared our proposals with include National Grid ESO; BEIS; the Scottish Government; Shetland, Western Isles and Orkney councils, MPs and MSPs; and all of the transmission-connecting and several distribution-level generators on those islands, including EdF, Forsa, Peel, Statkraft, Viking, DP Energy, Hoolan and Aquatera.</p> <p>Ofgem will shortly consult on the proposals publicly.</p>
--	--	---

	<p>position on an island contribution methodology in March 2019. Ofgem has noted its ability, in the existing (challenging) timescales, to reach a decision before the expected launch of the 2019 CfD auction (expected in May 2019). SHEPD's methodologies and proposed contribution values will be shared for stakeholder assessment and feedback at this point. We note that SHEPD has already carried out engagement with NGES, BEIS, the Scottish Government, island councils and MPs / MSPs and all relevant Shetland, Western Isles and Orkney developers on the contribution methodology, value, and pan-island approach.</p> <p>We therefore continue to recommend that the CMP 303 proposals are articulated and implemented in such a way as to clearly define the role and involvement of the relevant customer in identifying its need and its contribution towards costs for shared use of an asset. In the cases of HVDC transmission links to Shetland and the Western Isles, this customer would be SHEPD (and potentially also NGENSO, and perhaps others), and we suggest SHEPD's methodologies should determine the contribution for meeting distribution system needs.</p> <p>We have not commented on objectives (d) and (e).</p>		
--	--	--	--

<p>Aaron Priest, Viking Energy Wind Farm LLP</p>	<p>Viking Energy Wind Farm LLP (VEWF) believes that the proposed original and alternatives WACM1, WACM3, WACM4, WACM5 and WACM 7 would have a positive impact in</p> <p>Better facilitating competition (and cost reflectivity). Currently TNUoS charges for HVDC circuits include costs which are not properly cost reflective and which result in</p> <p>Distortion of competition by disadvantaging those generators who have to pay costs which are excluded on equivalent HVAC circuits. Fairer competition (and cost reflectivity) would be facilitated by recovering costs which more directly reflect the contractual export requirements of the generator on HVDC circuits. All the WACMs listed above contain this fundamental principle, as they contain the proposed original, and this should be borne in mind when considering other aspects of the WACMs.</p> <p>WACM1 includes the original, but also seeks a more</p> <p>Equitable TNUoS charging arrangement for HVDC converter stations. Work conducted by CIGRE, in direct follow-up to Project TransmiT, provides solid evidence that approximately half of the costs of HVDC converter stations can be attributed to components and functions which have the characteristics of HVAC substations. The cost of these VDC components and functions are</p>	<p>VEWF agrees that the implementation process and date should be compatible with the requirements of the announced May 2019 CfD auction. VEWf agrees that, if the CfD auction is to run fairly and competitively, all bidding plant must be able to properly understand and forecast the local circuit element of their TNUoS charge. Therefore a decision is required by the Authority in time for parties to take that decision into account when they participate in that auction.</p>	<p>VEWF wishes to reiterate its belief that there is strong evidence to suggest discriminatory TNUoS charging arrangements for HVDC circuits under the CUSC, as it stands, when compared to the treatment of HVAC circuits. VEWf wishes to reiterate that these arrangements are not properly cost reflective. Discrimination, and arrangements which are not properly cost reflective, would constitute a breach of GBSO licence conditions and need to be addressed and rectified quickly. It is arguable that the forthcoming May 2019 CfD auction's fairness and competitiveness could be called into question unless these anomalies are rectified quickly.</p> <p>The following text is lifted from the EU Renewable Energy Directive (2009/28/EC), which, according to the European Union (Withdrawal) Act 2018 will continue to apply post-Brexit.</p> <p>“3. Member States shall require transmission system operators</p> <p>and distribution system operators to set up and make public their standard rules relating to the bearing and sharing of costs of</p> <p>technical adaptations, such as grid connections a</p>
--	--	--	--

<p>currently unfairly recovered via local circuit charging arrangements on HVDC circuits, whilst for HVAC substations these costs are excluded from local circuit charges. As things stand, competition is distorted by the failure to act on this evidence and this perpetuates an inequality in charging arrangements between HVAC and HVDC circuits. Unequal treatment distorts competition (and cost reflectivity).</p> <p>WACM3 contains the original, but also seeks to identify additional functionality of HVDC circuits not required by exporting generators and not charged to exporting generators on equivalent HVAC circuits. These functions are reactive power, voltage control, power flow control and black start. For HVDC circuits the provision of these wider functions is charged to exporting generators within the local circuit charge, whilst on HVAC circuits they are not. Again, unequal treatment distorts competition (and cost-reflectivity).</p> <p>WACM4 contains the original, but recognises the additional function of island HVDC links in underpinning island security of supply. It recommends offsetting a capital value for this function which would be determined by the Authority. Competition (and cost-reflectivity) is facilitated under such an arrangement by recovering costs which more directly reflect the needs of the exporting generator.</p> <p>WACM5 is a hybrid of the original, WACM1 and WACM4. All these elements would better</p>		<p>interconnected grid.</p> <p>Those rules shall be based on objective, transparent and nondiscriminatory criteria taking particular account of all the costs and benefits associated with the connection of those producers to the grid and of the particular circumstances of producers located in peripheral regions and in regions of low population density. Those rules may provide for different types of connection.</p> <p>“7. Member States shall ensure that the charging of</p> <p>transmission and distribution tariffs does not discriminate against electricity from renewable energy sources, including in particular electricity from renewable energy sources produced in peripheral regions such as island regions and in regions of low population density.</p> <p>In regard to these two, separate, underlined legal obligations above, we would remind the CUSC Panel and the Authority that, in the case of the HVDC links to Shetland (and the Western Isles) these involve “in particular electricity from renewable energy sources produced in peripheral regions, such as island regions, and in regions of low population density”.</p>
---	--	---

	<p>facilitate competition (and cost-reflectivity) for the reasons laid out above and in the Final Workgroup Report. In capturing these separate elements, and with the converter station argument backed by CIGRE's evidence, WACM5 represents VEWf LLP's best option in better facilitating the relevant CUSC objectives of competition and cost reflectivity.</p> <p>WACM7 is a hybrid of the original, WACM3 and WACM4. Again, as laid out above and in the Final Workgroup report, all these constituent parts would better facilitate competition (and cost reflectivity).</p> <p>b) That compliance with the use of system charging methodology results in charges which reflect, as far as is reasonably practicable, the costs (excluding any payments between transmission licensees which are made under and accordance with the STC) incurred by transmission licensees in their transmission businesses and which are compatible with standard licence condition C26 requirements of a connect and manage connection); VEWf believes that the proposed original and alternatives WACM1, WACM3, WACM4, ACM5 and WACM 7 would have a positive impact in better facilitating cost reflectivity. Current HVDC TNUOS charging arrangements include charges which are not properly cost reflective and which are discriminatory when compared to treatment of equivalent export via HVAC circuits. The answers provided to (a) above apply equally to better facilitation of cost</p>		
--	---	--	--

	<p>reflectivity.</p> <p>WACM5 is a hybrid of the original, WACM1 and WACM4 All its constituent elements better facilitate cost-reflectivity (and competition) for the reasons laid out in (a) above and in the Final Workgroup Report. In capturing these separate elements, and with the converter station argument backed by CIGRE’s evidence, WACM5 represents VEWf LLP’s best option in better facilitating relevant CUSC objectives of competition and cost-reflectivity.</p> <p>(c) That, so far as is consistent with sub-paragraphs (a) and (b), the use of system charging methodology, as far as is reasonably practicable, properly takes account of the developments in transmission licensees’ transmission businesses; VEWf believes that the proposed original and alternatives WACM1, WACM3, WACM4, WACM5 and WACM 7 would help to ensure that the CUSC and use of system charging methodology treats HVDC links in a fair, more cost-reflective and non-discriminatory manner, as required within TOs’ transmission licences.</p> <p>(d) Compliance with the Electricity Regulation and any relevant legally</p>		
--	---	--	--

	<p>binding decision of the European Commission and/or the Agency. These are defined within the National Grid Electricity Transmission plc Licence under Standard Condition C10, paragraph 1*; For the reasons we detail in our answer to Q3 below, VEWf believes that the original and alternatives WACM1, WACM3, WACM4, WACM5 and WACM 7 would have a positive impact in better facilitating this objective as they ensure compliance with relevant legally binding EU law, namely EU Renewable Energy Directive (2009/28/EC) and in particular the two references (3 & 7) we quote in our answer to Q3 below. And</p> <p>(e) Promoting efficiency in the implementation and administration of the CUSC arrangements. VEWf believes that the original and the WACMs are neutral in terms of this objective.</p>		
--	--	--	--

10 Second Code Administrator Consultation Response Summary

The Second Code Administrator Consultation was issued on 4 October 2019 for 5 Working days, with a close date of 11 October 2019. Four responses were received to the Code Administrator Consultation and are detailed below. Please note, one confidential response was received to the Consultation.

The full responses to the Second Code Administrator Consultation can be found in Annex 13 of this report.

Respondent	Do you believe that the proposed original or any of the alternatives better facilitate the Applicable CUSC Objectives? Please include your reasoning.	Do you support the proposed implementation approach? If not, please state why and provide an alternative suggestion where possible.	Do you have any other comments?
EDF Energy	Overall the objectives are better met by the original and all WACMs except 4 to 7 inclusive, which do not better meet the objectives than original, or than baseline.	We support the proposed approach whereby Ofgem would, if it meets timescales, decide on this mod this year for implementation, if approved, from 1/4/2020.	No
Vattenfall Wind Power Ltd	We welcome this second consultation round and that Ofgem has asked the CMP 303 working group to better substantiate the proposals made in the working group. Overall, we welcome CMP 303 as a long overdue recognition that the existing charging arrangements for HVDC links are not cost reflective and change is needed	We support the proposed implementation approach and in particular that of WACM 3 which is well substantiated by Annex 9 and 10, provides a clear method of implementation, and, is most cost reflective as it looks at each HVDC link on a case by case basis and shows (through Annex 9 and 10) that this is necessary.	None
Uniper	No, we continue to believe that the modifications are worse than the current baseline as they reduce cost reflectivity of the links and introduce discriminatory treatment compared with other elements of the transmission network. Our full comments in this respect can be found in our response to the original Code Administrator consultation. We believe that a more appropriate solution has already been implemented under CMP301.	No, we do not support implementation of the modification.	In the limited time provided for in this relatively short consultation period of 5 working days, it has not been possible to fully assess the implications of these papers, but they largely seem to summarise evidence which was provided at the time of CMP213 either in Project Transmit, CMP213 and the CIGRE documents. It did not appear to be new evidence as such. It also appeared to be mainly provided in support of WACM 3 to the modification which we understand to be very similar in nature to the changes introduced under CMP301. Therefore, we would suggest that this has been superseded by the decision to implement that modification proposal. The full response can be found within Annex 13.
Non- Disclosed Response	We are supportive of the original and WACMs 1,2,3,8 and 9 as shown in our previous voting statement. These	Yes	No

	<p>WACMs provide various degrees of assistance in meeting the CUSC objectives. We note that since the original consultation, NGET have carried out detailed work to demonstrate the impact of these WACMs on demand tariffs.</p>		
--	--	--	--

11 CUSC Panel Vote

At the CUSC Panel meeting on 25 October 2019, the Panel voted on CMP303 against the Applicable CUSC Charging Objectives.

At the CUSC Panel meeting on 25 October 2019, the Panel Members by majority recommended that the Original and WACM3 better facilitated the CUSC objectives than the baseline.

For reference the Applicable CUSC Charging Objectives are;

(a) That compliance with the use of system charging methodology facilitates effective competition in the generation and supply of electricity and (so far as is consistent therewith) facilitates competition in the sale, distribution and purchase of electricity;

(b) That compliance with the use of system charging methodology results in charges which reflect, as far as is reasonably practicable, the costs (excluding any payments between transmission licensees which are made under and accordance with the STC) incurred by transmission licensees in their transmission businesses and which are compatible with standard license condition C26 requirements of a connect and manage connection);

(c) That, so far as is consistent with sub-paragraphs (a) and (b), the use of system charging methodology, as far as is reasonably practicable, properly takes account of the developments in transmission licensees' transmission businesses;

(d) Compliance with the Electricity Regulation and any relevant legally binding decision of the European Commission and/or the Agency. These are defined within the National Grid Electricity Transmission plc. License under Standard Condition C10, paragraph 1; and

(e) Promoting efficiency in the implementation and administration of the system charging methodology.

Vote 1: Does the Original, WACM1, WACM2, WACM3, WACM4, WACM5, WACM6, WACM7, WACM8 and WACM9 facilitate the objectives better than the Baseline?

Panel Member: Andy Pace

	Better facilitates ACO (a)	Better facilitates ACO (b)?	Better facilitates ACO (c)?	Better facilitates ACO (d)?	Better facilitates ACO (e)?	Overall (Y/N)
Original	Y	Y	Neutral	Neutral	Neutral	Y
WACM1	N	N	Neutral	Neutral	Neutral	N
WACM2	N	N	Neutral	Neutral	Neutral	N
WACM3	Y	Y	Neutral	Neutral	N	Y
WACM4	N	N	Neutral	Neutral	N	N

WACM5	N	N	N	Neutral	N	N
WACM6	N	N	N	Neutral	N	N
WACM7	N	N	N	Neutral	N	N
WACM8	N	N	N	Neutral	Neutral	N
WACM9	N	N	N	Neutral	Neutral	N

Voting Statement

The original proposal results in a more cost reflective allocation of costs and therefore better meets applicable objectives (a) and (b) as it facilitates effective competition in the generation and supply of electricity. This will allow island projects to participate more effectively in future CfD auctions.

WACM1 and WACM2 propose to remove 50% or 100% of the costs associated with HVDC converter stations. The rationale for this is that the equivalent assets are socialised for onshore AC substations. We do not believe this results in an increase in cost reflectivity as these asset costs would be socialised and the cost fall on other generators or consumers. The fact that costs are socialised elsewhere should not set a precedent, rather the underlying principle should be reviewed. We would expect the scope of this work to be covered under the Ofgem SCR on network access and forward looking charges.

WACM3 proposes for a bespoke calculation on a case by case. We believe that this is likely to result in more cost reflective charges and therefore better meets applicable objectives (a) and (b). However, we are also concerned that the resultant charge will be based on the capability of the asset rather than how they are used which may lessen the impact. We are also concerned that WACM3 will worsen objective (e) as it places a considerable administrative burden on NGESO according to their consultation response.

WACM4 introduces the concept of an offset element linked to the cost of a distribution variation for the network solution. Generally, we see the HVDC links as primarily being generation led and therefore the proposed solution of transmission rather than distribution is the basis on which the costs should be derived. To introduce a concept of alternative distribution assets in this instance would need to be considered as a principle and applied across the board rather than selecting a case where it is beneficial. We therefore do not consider that WACM4 better meets applicable objectives (a), (b) and (e).

WACMs 5, 6, and 7 all include the element of WACM4 which we do not believe better meets applicable objectives (a), (b) and (e).

WACM8 proposes to pro-rate the import potential to the island and the export rating to determine a deduction from the local circuit tariff. We are concerned that this will over-allocate costs to the import and therefore does not better meet applicable objectives (a) and (b). As stated above, we believe that these assets are primarily required for generation and pro-rating the charges based on peak demand would over allocate the

costs to consumers.

WACM9, includes the element of WACM8 which we do not believe better meets applicable objectives (a) and (b).

Panel Member: Garth Graham

	Better facilitates ACO (a)	Better facilitates ACO (b)?	Better facilitates ACO (c)?	Better facilitates ACO (d)?	Better facilitates ACO (e)?	Overall (Y/N)
Original	Y	Y	Y	Y	Neutral	Y
WACM1	Y	Y	Y	Y	Neutral	Y
WACM2	N	N	N	N	Neutral	N
WACM3	Y	Y	Y	Y	Neutral	Y
WACM4	Y	Y	Y	Y	Neutral	Y
WACM5	Y	Y	Y	Y	Neutral	Y
WACM6	N	N	N	N	Neutral	N
WACM7	Y	Y	Y	Y	Neutral	Y
WACM8	N	N	N	N	Neutral	N
WACM9	N	N	N	N	Neutral	N
Voting Statement						
<p>The Original, WACM1, WACM3, WACM4, WACM5 and WACM7 are better in terms of facilitating Applicable Objectives (a), (b), (c) and (d) whilst being neutral in terms of (e). Overall, they are all better than the baseline. They ensure that the charging methodology better facilitates competition as the charges associated with HVDC links are applied more cost reflectively on those that give rise to them, whilst also ensuring that EU law relating to transmission charging and renewables is taken fully into consideration; in particular, regarding island regions, peripheral regions and regions of low population density. In considering WACMs 4, 5 and 7 I've also taken into account that the proposal is an enabling one with each of the changes allowing the Authority to determine, if appropriate, a £ figure to be applied on a case by case basis to ensure an outcome, in terms of charging, which is in the best interest of consumers in light of the Authority's wider statutory duties (including compliance with EU law). In terms of WACMs 2, 6, 8 and 9 I do not believe that they achieve charges that are more cost reflective and so are not better in terms of Applicable Objectives (a) and (c) or, as a result (b) in terms of competition and they do not appear to be better in terms of the wider aspects of EU law (so are not better in terms of (d)).</p>						

Panel Member: Jon Wisdom

	Better facilitates ACO (a)	Better facilitates ACO (b)?	Better facilitates ACO (c)?	Better facilitates ACO (d)?	Better facilitates ACO (e)?	Overall (Y/N)
Original	Y	N	Neutral	Neutral	Neutral	Y
WACM1	Y	N	Neutral	Neutral	Neutral	N
WACM2	Y	N	Neutral	Neutral	Neutral	N
WACM3	N	N	Neutral	Neutral	N	N
WACM4	N	N	N	Neutral	N	N
WACM5	N	N	N	Neutral	N	N
WACM6	N	N	N	Neutral	N	N
WACM7	N	N	N	Neutral	N	N
WACM8	N	N	N	Neutral	N	N
WACM9	N	N	N	Neutral	N	N
Voting Statement						
<p>Original</p> <p>As per our consultation response we expressed a support for the original in better fulfilling ACO (a) by enabling island projects to participate more effectively in the CfD auctions albeit with a small negative impact to consumers. We are satisfied that the potentially large reduction in cost reflectivity is accounted for in the legal text which very clearly deducts costs for additional functionality only when the Relevant Transmission Owner can provide two clear costs to calculate the differential. Therefore, we are supportive of the Original in facilitating the ACO better than Baseline CUSC.</p> <p>WACM1</p> <p>Despite WACM1 providing the same competition benefits as the Original we believe in this case that the negative impact on cost reflectivity outweighs the positive impact on competition as it socialises significantly more costs amongst all GB generation users (as the charging methodologies currently stand). Therefore, we are not supportive of WACM1 in facilitating the ACO better than Baseline CUSC.</p>						

WACM2

Despite WACM2 providing the same competition benefits as the Original we believe in this case that the negative impact on cost reflectivity outweighs the positive impact on competition as it socialises significantly more costs amongst all GB generation users (as the charging methodologies currently stand). Therefore, we are not supportive of WACM2 in facilitating the ACO better than Baseline CUSC.

WACM3

WACM3 places a much greater burden on the Relevant Transmission Licensee and NGESO revenue teams to make bespoke calculations on a case by case basis significantly worsening ACO (e). We do not believe there are any benefits to the other ACOs to negate this. We are especially concerned about setting a precedent where users are paid/receive a discount based on the capability of an asset instead of how it is actually used in practice. There are still some outstanding questions on how practicable this WACM is in terms of the data required in the proposed methodology. For all of these reasons we do not support WACM3.

WACM4

Although we are sympathetic to the proposer's intentions here we are reluctant to support this WACM as we are concerned that there has been a lack of transparency in the development of the WACM and therefore industry have not had chance to input into the development process. The draft legal text is very broad and has no provisions for public reporting of the proposed transfers – we feel this does not better facilitate competition. Additionally, as the text currently stands it could be generically applied to a range of third parties and lacks clarity on how a “commensurate reduction” would be calculated. On the principle, we are cautiously supportive of a whole system approach but are wary of taking into

account assets that are only potentially to be built which will require many assumptions to be made. We would be concerned about the transparency of these needs cases as the legal text doesn't specify that the Authority must make a ruling on the amount to be transferred on a case by case basis. WACM4 combines the Original and the “DUoS offset” proposal – we believe there may be scope for double counting of perceived demand benefits here. Consequently, we do not support WACM4.

WACM5

As this WACM is a hybrid of earlier options please see comments on the individual options.

WACM6

As this WACM is a hybrid of earlier options please see comments on the individual options.

WACM7

As this WACM is a hybrid of earlier options please see comments on the individual options.

WACM8

WACM8 proposes an alternative solution to the defect by “pro-rating” the import potential to the island and the export rating to determine a deduction from the local circuit tariff. We believe this method overstates the benefits provided to demand on the island from a newly built transmission link by taking the peak demand on the island with the potential for double counting and not producing an accurate picture of the actual usage of the link for import. We are especially concerned about setting a precedent where users are paid/receive a discount based on the capability of an asset instead of how it is actually used in practice. There are still some outstanding questions on how practicable this WACM is in terms of the data required in the proposed methodology. For all of these reasons we do not support WACM8.

WACM9

As this WACM is a hybrid of earlier options please see comments on the individual options.

Panel Member: Cem Suleyman

	Better facilitates ACO (a)	Better facilitates ACO (b)?	Better facilitates ACO (c)?	Better facilitates ACO (d)?	Better facilitates ACO (e)?	Overall (Y/N)
Original	Y	Y	Y	Neutral	Neutral	Y
WACM1	N	N	N	Neutral	Neutral	N
WACM2	N	N	N	Neutral	Neutral	N
WACM3	N	N	N	Neutral	Neutral	N
WACM4	N	N	N	Neutral	Neutral	N
WACM5	N	N	N	Neutral	Neutral	N
WACM6	N	N	N	Neutral	Neutral	N
WACM7	N	N	N	Neutral	Neutral	N
WACM8	N	N	N	Neutral	Neutral	N
WACM9	N	N	N	Neutral	Neutral	N
Voting Statement						

I believe that the Original better facilitates the Applicable CUSC Objectives, whilst all the WACMs do not better facilitate the Applicable CUSC Objectives for broadly the same reasons expressed by the ESO CUSC Panel Member.

Panel Member: Mark Duffield

	Better facilitates ACO (a)	Better facilitates ACO (b)?	Better facilitates ACO (c)?	Better facilitates ACO (d)?	Better facilitates ACO (e)?	Overall (Y/N)
Original	Y	Neutral	Y	Neutral	N	N
WACM1	Neutral	Neutral	Y	Neutral	N	N
WACM2	Neutral	Neutral	Y	Neutral	N	N
WACM3	Neutral	Neutral	Y	Neutral	N	N
WACM4	Y	Neutral	Y	Neutral	N	N
WACM5	Neutral	Neutral	Y	Neutral	N	N
WACM6	Neutral	Neutral	Y	Neutral	N	N
WACM7	Neutral	Neutral	Y	Neutral	N	N
WACM8	Y	Neutral	Y	Neutral	Neutral	Y
WACM9	Neutral	Neutral	Y	Neutral	N	N
Voting Statement						

ACO (a): Trade off between the overall aims of the modification proposal and the alternates that seek to appropriately determine the correct split between generation and demand charges and the specificity with which they seek to do this. The Original, WACM4 and WACM8 all have a methodological approach for determining adjustments to the tariff. this ensures a consistent treatment for different projects / island connections. All of the others have to differing degrees a subjective approach which may vary between licensees, or a deterministic approach whereby assumptions are made that apply to all projects regardless of their specific situation. These amendments are rated neutral as the benefits of the overall approach are offset by these

inefficiencies.

ACO (b): Neutral, the correct costs will be recovered whichever amendment is selected or if all are rejected.

ACO (c): All recognise the implementation of DC connections which may become more commonplace

ACO (d): Not relevant

ACO (e): All except WACM 8 introduce further subjectivity into the charging methodology by allowing a Transmission Licensee to decide adjustments, without recourse to a specific methodology, to determine adjustments. This increases the likelihood of different licensees approaching a similar connection in different ways, increasing the likelihood of disputes or undue discriminatory treatment between users. WACM8 does not do this.

Panel Member: Joe Dunn

	Better facilitates ACO (a)	Better facilitates ACO (b)?	Better facilitates ACO (c)?	Better facilitates ACO (d)?	Better facilitates ACO (e)?	Overall (Y/N)
Original	Y	Y	Y	Neutral	Neutral	Y
WACM1	Y	Y	Y	Neutral	Neutral	Y
WACM2	N	N	N	Neutral	Neutral	N
WACM3	Y	Y	Y	Neutral	Neutral	Y
WACM4	N	N	N	Neutral	Neutral	N
WACM5	N	N	N	Neutral	Neutral	N
WACM6	N	N	N	Neutral	Neutral	N
WACM7	N	N	N	Neutral	Neutral	N
WACM8	N	N	N	Neutral	Neutral	N
WACM9	N	N	N	Neutral	Neutral	N
Voting Statement						
Original - Costs incurred to provide a generator transmission connection which are incurred for reasons other than the ability to export should be excluded from the specific local circuit charges applied to that generator. Such costs may arise from providing the additional capability to provide for two-way flows to support demand security.						
WACM1 - Agree if aligned to WACM3 that an approximation should be possible and						

would provide greater simplicity and predictability to Users.

WACM3 - Further to 'Original' it is entirely sensible to include the capability to provide other ancillary services. Identifying the incremental cost of facilitating bi-directional flows should be feasible from the original needs case including separating the costs of items providing additional ancillary services functionality.

Excluding such costs places generators subject to local circuit charges on a level footing with mainland generators and better facilitates competition (Applicable Charging Objective (a)). Excluding such costs ensures that the local circuit charge only reflects the costs of providing the generator connection and better facilitates ACO (b). The development of island connections has only recently commenced and developing appropriate charging arrangements better facilitates ACO (c). All the proposals are neutral against ACOs (d) and (e)

While some HVDC converter station costs do provide additional functionality, this equipment is required to enable the basic function of HVDC circuits. Therefore, excluding all converter station costs (WACMs 2, 6, 9) would not be cost reflective or better facilitate competition. Identification of the additional benefits of an HVDC circuit vs a distribution solution would be subjective therefore not transparent. Therefore WACMs 4, 5, 6 & 7 do not better meet the ACOs. There is insufficient evidence that pro-rating the costs of a circuit on the basis of its import/export capability would provide an accurate allocation of the costs attributable to each capability and could lead to less cost reflective charging. Therefore, WACMs 8 & 9 do not better meet the ACOs.

Panel Member: Andrew Enzor (Alternate for Grace Smith)

	Better facilitates ACO (a)	Better facilitates ACO (b)?	Better facilitates ACO (c)?	Better facilitates ACO (d)?	Better facilitates ACO (e)?	Overall (Y/N)
Original	Y	Y	Y	Neutral	Neutral	Y
WACM1	Y	Y	Y	Neutral	Neutral	Y
WACM2	N	N	N	Neutral	Neutral	N
WACM3	Y	Y	Y	Neutral	N	Y
WACM4	N	N	N	Neutral	Neutral	N
WACM5	N	N	N	Neutral	Neutral	N
WACM6	N	N	N	Neutral	Neutral	N
WACM7	N	N	N	Neutral	Neutral	N
WACM8	N	N	N	Neutral	Neutral	N

WACM9	N	N	N	Neutral	Neutral	N
Voting Statement						
<p>Options which remove some of the cost of AC sub-sea and HVDC links from the calculation of generator local circuit charges on a sound justifiable basis better meet ACOs (a), (b) and (c). Ensuring generators are only exposed to the relevant aspects of AC sub-sea and HVDC link costs will result in charges which are more cost-reflective (ACO (b)), improving competition between remote island and mainland generators (ACO (a)) and thus taking account of developments in licensees' businesses as remote island HVDC links become more widespread (ACO (c)).</p> <p>This justification has been achieved for the Original, WACM1 and WACM3:</p> <p>The Original and WACM3 achieve this by enabling the TO to identify the cost of additional functionality on a case by case basis. WACM3 introduces significant complexity and so ACO (e) is not facilitated as well as the baseline, but this is more than offset by better facilitation of other ACOs.</p> <p>WACM1 achieves this by reducing the costs using a 50% reduction in converter costs as justified by analysis undertaken under CMP 213.</p> <p>The reduction in cost proposed by the remaining WACMs is not sufficiently well justified:</p> <p>WACM2 uses an arbitrary reduction factor of 100% for converter costs which is not backed up by evidence.</p> <p>WACM4 (and WACMs 5, 6 and 7 which incorporate it) conflates the additional cost required for bi-directionality with the costs of providing a distribution link. Cost-reflective TNUoS charges should be based on the cost of transmission assets; those costs are not directly impacted by the cost of distribution equivalents.</p> <p>WACM8 (and WACM 9 which incorporates it) risks over-discounting through the use of a flawed method of pro-rating costs between demand and generation.</p>						

Panel Member: Paul Jones

	Better facilitates ACO (a)	Better facilitates ACO (b)?	Better facilitates ACO (c)?	Better facilitates ACO (d)?	Better facilitates ACO (e)?	Overall (Y/N)
Original	N	N	N	Neutral	Neutral	N
WACM1	N	N	N	Neutral	Neutral	N
WACM2	N	N	N	Neutral	Neutral	N
WACM3	N	N	N	Neutral	Neutral	N
WACM4	N	N	N	Neutral	Neutral	N

WACM5	N	N	N	Neutral	Neutral	N
WACM6	N	N	N	Neutral	Neutral	N
WACM7	N	N	N	Neutral	Neutral	N
WACM8	N	N	N	Neutral	Neutral	N
WACM9	N	N	N	Neutral	Neutral	N

Voting Statement

This would result in different treatment for these assets compared with that for onshore circuits. The methodology for onshore circuits reflects the cost of the relevant asset regardless of whether or not it was built entirely for the generation (or demand) concerned. It seeks to provide a marginal signal to reflect the use of the assets concerned, the signal for demand being the opposite of that for generation. It is not a cost recovery mechanism. It calculates, through a loadflow model, what an additional MWkm would cost to transport over the asset concerned (or indeed how much would be saved with a reduction in flow). By artificially reducing the cost per MWkm of the assets concerned, this proposal would reduce cost reflectivity of that signal and would therefore undermine competition in the wholesale market.

The WACMs which seek to socialise the costs of converter stations go beyond the scope of the defect stated in the modification proposal and further reduce cost reflectivity. Ofgem's view on converter stations under CMP213 was that they should form part of the circuit cost of the link concerned, but they did say that they would be open to new arguments on this issue. However, no convincing ones seem to have been forthcoming as a result of CMP303 even after the send back.

The converter stations may be able to provide some functionality which is similar to that provided in different ways onshore, but there seems to be little evidence that this has been in response to an actual wider system need, over and above perhaps overcoming issues which arise in stepping between the AC and DC systems when HVDC technology is used. With other network assets such as quad boosters, these have been deliberately designed in order to meet a specific system need. It is not clear why credits would be allocated against these assets for this in the charging methodology.

The argument around the provision of black start services seems to either be based on the fact that a cable to an island could allow the customers on that island to be re-energised following a black start event, or that HVDC links can provide black start services from generators connected at the other end to the rest of the network. The first of these instances is no different from any part of the transmission network. It does not provide a black start service as such, just a route for delivery to a particular part of the network. In the second instance it is not clear how an island dominated by wind power would be regarded as a reliable black start source for the rest of the network. However, even if those generators could provide the service, it is they who should be rewarded for this not the network asset.

CMP301 has introduced more appropriate arrangements so the baseline is the best option.

Panel Member: Paul Mott

	Better facilitates ACO (a)	Better facilitates ACO (b)?	Better facilitates ACO (c)?	Better facilitates ACO (d)?	Better facilitates ACO (e)?	Overall (Y/N)
Original	Y	Y	Y	Neutral	Neutral	Y
WACM1	Y	Y	Y	Neutral	Neutral	Y
WACM2	Y	Y	Y	Neutral	Neutral	Y
WACM3	Y	Y	Y	Neutral	Neutral	Y
WACM4	N	N	Neutral	Neutral	Neutral	N
WACM5	N	N	Neutral	Neutral	Neutral	N
WACM6	N	N	Neutral	Neutral	Neutral	N
WACM7	N	N	Neutral	Neutral	Neutral	N
WACM8	Y	Y	Y	Neutral	Neutral	Y
WACM9	Y	Y	Y	Neutral	Neutral	Y
Voting Statement						

Regarding (a) (facilitates effective competition....) – the original and the WACMs indicated allow relevant generators to compete fairly in the market without being handicapped by paying extra costs unrelated to the export of their power.

Regarding (b) (.....charges which reflect costs), the original and the WACMs indicated above ensure relevant generators face a cost-reflective local circuit charge, without paying for extra costs unrelated to the export of their power, or costs which benefit other users and not the connecting generators.

Regarding (c) (...properly takes account of the developments in transmission licensees' transmission businesses), the original and the WACMs as indicated in the table better meet this, as for instance HVDC island links (to which the original isn't, mind you, limited) don't exist yet. The original, among other scenarios, covers the case where the TO adds bidirectionality as a function to such a link – so that such a development would be properly taken account of in a fair and cost-reflective manner. The WACMs as indicated in the table also take account of HVDC developments.

(d) Compliance with the Electricity Regulation and (e) Promoting efficiency in the implementation and administration of the CUSC arrangements, do not seem relevant.

Thus, overall the objectives are better met for the WACMs indicated above in the table.

WACM 8 offers a particularly straightforward methodology for reflecting the level of demand import and the benefit that that brings, which avoids the need for TO assessments/judgements and is intuitively and readily comprehensible.

WACM4 and the derivatives that include it do not need a CUSC mod, if Ofgem wants to do this - it can be done outwith the CUSC. Moreover the cost removal that SHEPD proposes (to be reassigned out of the local circuit charge and onto consumers) assumes that consumers were not previously funding any of that island link, yet this is not the case; the local circuit charge is calculated based on full utilisation, costs being amortised over entire link capacity, yet this local circuit charge is then charged out according to TEC, so if sum of TEC on the relevant island is less than link capacity, some of the local circuit cost falls onto the consumers via the TDR. The proposed cost removal in the SHEPD proposals, recently consulted on, that lie behind WACM4 and the derivatives that include it are for this reason unable to effectively take forward cost-reflectivity as consumers seem to be being charged too much. They attempt to address developments in transmission licensees' transmission businesses, but do so ineffectively for this reason.

At the CUSC Panel meeting on 25 October 2019, the Panel Members by majority recommended that the Original (7 out of 9 votes) and WACM3 (5 out of 9 votes) better facilitated the CUSC objectives than the baseline.

It is also worth highlighting that 4 of the 9 Panel members believed that WACM1 better facilitated the CUSC objectives than the baseline.

Vote 2 – Which option is the best?

The CUSC Panel members also identified their best option and there was a range of views. There were 4 votes for the Original, 2 votes for WACM8, 1 vote for WACM3, 1 vote for WACM5 and 1 vote for the Baseline.

Panel Member	BEST Option?
Andy Pace	Original
Garth Graham	WACM5
Jon Wisdom	Original
Cem Suleyman	Original
Mark Duffield	WACM8
Joe Dunn	WACM3
Andrew Enzor (Alternate for	Original

Grace Smith)	
Paul Jones	Baseline
Paul Mott	WACM8

12 Legal Text

This can be found within Annex 7 of this report.

13 Impacts

Costs

Industry costs (Standard CMP)	
Resource costs	£85, 305 – 3 Consultations <ul style="list-style-type: none"> • 8 Workgroup meetings • 10 Workgroup members • 1.5 man days effort per consultation response • 10 consultation respondents
Total Industry Costs	£100, 324

14 Annex 1: CMP303 Terms of Reference

Workgroup Terms of Reference and Membership

TERMS OF REFERENCE FOR CMP303 WORKGROUP

CMP303 seeks to make part of the TNUoS charge more cost-reflective through removal of additional costs from local circuit expansion factors that are incurred beyond the connected, or to-be-connected, generation developers' need.

Responsibilities

1. The Workgroup is responsible for assisting the CUSC Modifications Panel in the evaluation of CUSC Modification Proposal **CMP303** Improving local circuit charge cost-reflectivity, tabled by EDF Energy at the Modifications Panel meeting on 27 July 2018.
2. The proposal must be evaluated to consider whether it better facilitates achievement of the Applicable CUSC Objectives. These can be summarised as follows:

Non-Standard (Charging) Objectives

- a. That compliance with the use of system charging methodology facilitates effective competition in the generation and supply of electricity and (so far as is consistent therewith) facilitates competition in the sale, distribution and purchase of electricity;
 - b. That compliance with the use of system charging methodology results in charges which reflect, as far as is reasonably practicable, the costs (excluding any payments between transmission licensees which are made under and accordance with the STC) incurred by transmission licensees in their transmission businesses and which are compatible with standard licence condition C26 requirements of a connect and manage connection);
 - c. That, so far as is consistent with sub-paragraphs (a) and (b), the use of system charging methodology, as far as is reasonably practicable, properly takes account of the developments in transmission licensees' transmission businesses;
 - d. Compliance with the Electricity Regulation and any relevant legally binding decision of the European Commission and/or the Agency. These are defined within the National Grid Electricity Transmission plc Licence under Standard Condition C10, paragraph 1 *; and
 - e. Promoting efficiency in the implementation and administration of the CUSC arrangements.
3. It should be noted that additional provisions apply where it is proposed to modify the CUSC Modification provisions, and generally reference should be made to the Transmission Licence for the full definition of the term.

Scope of work

4. The Workgroup must consider the issues raised by the Modification Proposal and consider if the proposal identified better facilitates achievement of the Applicable CUSC Objectives.
5. In addition to the overriding requirement of paragraph 4, the Workgroup shall consider and report on the following specific issues:
 - a) Understanding the impacts on wider and local tariffs
 - b) Understanding the impact on generation and demand concerned
 - c) Consideration of the overall benefits of the change v impact on consumers
 - d) Clarify source and process of information required to determine the cost to be proportioned
6. The Workgroup is responsible for the formulation and evaluation of any Workgroup Alternative CUSC Modifications (WACMs) arising from Group discussions which would, as compared with the Modification Proposal or the current version of the CUSC, better facilitate achieving the Applicable CUSC Objectives in relation to the issue or defect identified.
7. The Workgroup should become conversant with the definition of Workgroup Alternative CUSC Modification which appears in Section 11 (Interpretation and Definitions) of the CUSC. The definition entitles the Group and/or an individual member of the Workgroup to put forward a WACM if the member(s) genuinely believes the WACM would better facilitate the achievement of the Applicable CUSC Objectives, as compared with the Modification Proposal or the current version of the CUSC. The extent of the support for the Modification Proposal or any WACM arising from the Workgroup's discussions should be clearly described in the final Workgroup Report to the CUSC Modifications Panel.
8. Workgroup members should be mindful of efficiency and propose the fewest number of WACMs possible.
9. All proposed WACMs should include the Proposer(s)'s details within the final Workgroup report, for the avoidance of doubt this includes WACMs which are proposed by the entire Workgroup or subset of members.
10. There is an obligation on the Workgroup to undertake a period of Consultation in accordance with CUSC 8.20. The Workgroup Consultation period shall be for a period of **15 working days** as determined by the Modifications Panel.
11. Following the Consultation period the Workgroup is required to consider all responses including any WG Consultation Alternative Requests. In undertaking an assessment of any WG Consultation Alternative Request, the Workgroup should consider whether it better facilitates the Applicable CUSC Objectives than the current version of the CUSC.

As appropriate, the Workgroup will be required to undertake any further analysis and update the original Modification Proposal and/or WACMs. All responses including any WG Consultation Alternative Requests shall be included within the final report including a summary of the Workgroup's

deliberations and conclusions. The report should make it clear where and why the Workgroup chairman has exercised his right under the CUSC to progress a WG Consultation Alternative Request or a WACM against the majority views of Workgroup members. It should also be explicitly stated where, under these circumstances, the Workgroup chairman is employed by the same organisation who submitted the WG Consultation Alternative Request.

12. The Workgroup is to submit its final report to the Modifications Panel Secretary in March 2019 for circulation to Panel Members. The final report conclusions will be presented to the CUSC Modifications Panel meeting on 29 March 2019.

Membership

13. It is recommended that the Workgroup has the following members:

Role	Name	Representing
Chairman	Shazia Akhtar	National Grid ESO
National Grid Representative	Eleanor Horn	National Grid ESO
Industry Representatives	Paul Mott	EDF (Proposer)
	Nigel Scott	Xero
	Simon Swaitek	Forsa
	Guy Nicholson	Stakraft
	Sharron Gordon	SHETL
	Garth Graham	SSE Generation Plc
	Aaron Priest	VEWF LLP
Authority Representatives	Tim Aldridge	OFGEM
Technical secretary	Joseph Henry	National Grid ESO

NB: A Workgroup must comprise at least 5 members (who may be Panel Members). The roles identified with an asterisk in the table above contribute toward the required quorum, determined in accordance with paragraph 14 below.

14. The chairman of the Workgroup and the Modifications Panel Chairman must agree a number that will be quorum for each Workgroup meeting. The agreed figure for CMP303 is that at least 5 Workgroup members must participate in a meeting for quorum to be met.
15. A vote is to take place by all eligible Workgroup members on the Modification Proposal and each WACM. The vote shall be decided by simple majority of those present at the meeting at which the vote takes place (whether in person

or by teleconference). The Workgroup chairman shall not have a vote, casting or otherwise]. There may be up to three rounds of voting, as follows:

- Vote 1: whether each proposal better facilitates the Applicable CUSC Objectives;
- Vote 2: where one or more WACMs exist, whether each WACM better facilitates the Applicable CUSC Objectives than the original Modification Proposal;
- Vote 3: which option is considered to BEST facilitate achievement of the Applicable CUSC Objectives. For the avoidance of doubt, this vote should include the existing CUSC baseline as an option.

The results from the vote and the reasons for such voting shall be recorded in the Workgroup report in as much detail as practicable.

16. It is expected that Workgroup members would only abstain from voting under limited circumstances, for example where a member feels that a proposal has been insufficiently developed. Where a member has such concerns, they should raise these with the Workgroup chairman at the earliest possible opportunity and certainly before the Workgroup vote takes place. Where abstention occurs, the reason should be recorded in the Workgroup report.
17. Workgroup members or their appointed alternate are required to attend a minimum of 50% of the Workgroup meetings to be eligible to participate in the Workgroup vote.
18. The Technical Secretary shall keep an Attendance Record for the Workgroup meetings and circulate the Attendance Record with the Action Notes after each meeting. This will be attached to the final Workgroup report.
19. The Workgroup membership can be amended from time to time by the CUSC Modifications Panel.

15 Annex 2: CMP303 Attendance Register

Name	Company/role	25/09/2018	29/10/2018	30/10/2018	20/12/2018	24/01/2019	08/02/2019	12/02/2019	13/02/2019	17/07/2019	29/08/2019
Joseph Henry	National Grid ESO (Chair)	A/D	A	A	A/D	A	A	A	A	A	A
Shazia Akhtar	National Grid ESO (Tech Sec)	A/D	A	A	A/D	A	A	A	A	O	O
Garth Graham	SSE	A/D	A/D	X	A/D	A	A/D	A/D	A/D	A/D	A/D
Andy Colley	SSE Alternative	X	X	A/D	X	X	X	X	X	X	X
Paul Mott (Proposer)	EDF Energy	A/D	A	A	A/D	A/D	A/D	A/D	A/D	A	A
Simon Swiatek	Forsa Energy	A/D	A	A	A/D	A/D	A/D	A/D	A/D	A	A
Guy Nicholson	Element Power	A/D	A	A	A/D	X	X	O	O	X	X
Ankita Mehra	Ofgem	X	X	X	X	X	A/D	X	X	O	O
Tim Aldridge	Ofgem	A/D	X	X	A/D	A/D	X	A/D	A/D	A/D	A/D
Urmi Mistry	NGESO	A/D	X	A/D	X	X	X	X	X	X	X
Harriet Harmon	NGESO Alternative	X	A/D	X	A/D	A	X	X	X	x	x
Eleanor Horne	NGESO Rep	X	X	X	A/D	A	X	X	A	O	O
Simon Sheridan	NGESO Alternative	X	X	X	X	X	A	O	O	X	X
Nigel	Xero Energy	A/D	A	A	A/D	A/D	A/D	X	X	A	A

Scott											
Sharon Gordon	SHETL	X	A	A/D	A/D	A/D	A/D	A/D	A/D	X	X
Aaron Priest	Viking Energy	X	X	X	A/D	A/D	A/D	A/D	O	A/D	A/D

A – Attended

A/D Dialed in

O – Alternate

X – Did not attend

16 Annex 3: Workgroup Consultation Responses



Energy

National Grid ESO
Faraday House
Warwick Technology Park
Gallows Hill
Warwick
CV34 6DA

21st January 2019

CMP303 consultation

Dear Sir/Madam,

We welcome this opportunity to respond to the CMP303 consultation issued on 21 December 2018. We consider this consultation very timely as needs case submissions for the Scottish Islands, including Shetland, are presently being made to Ofgem, and the island CfD auction is imminent.

About The Peel Group

The Peel Group (Peel) was founded in 1920 and has its head office in Greater Manchester. Peel is one of the United Kingdom's foremost privately owned investment enterprises, embracing a broad range of sectors including land and property; ports and airports; transport and logistics; retail and leisure and energy and media. Across the organisation, Peel employs over 2,500 full time employees. Since 2008, Peel have invested over £5.4bn of capital in the UK, delivering over 133,000 direct and indirect jobs including 66,000 within the Northern Powerhouse, and contributing Gross Value Add (GVA) of £27bn. Peel is proud of its legacy of delivering prosperous communities for the UK.

Remote Islands Wind (RIW)

Peel welcomed the Government's manifesto commitment to "support the development of wind projects in the remote islands of Scotland where they directly benefit local communities". We are committed to driving long-term growth in the Shetland Islands, whilst helping unlock benefits from RIW of up to £725m of GVA¹, which have the lowest estimated productivity levels of any region in the UK, trailing the national average by 23%².

Peel's Shetland Islands Projects

Peel Energy, a subsidiary of the Peel Group, has been developing two RIW projects on the Shetland Islands – Beaw Field Wind Farm (72MW) and Mossy Hill Wind Farm (49.9MW). Beaw Field is a consented project with a signed grid connection offer, and Mossy Hill is in the planning system with determination expected shortly and has a grid connection offer which is currently being progressed. These projects have the potential to make a significant impact to local communities. Further details of these benefits are available if you wish to have further information.

Consultation questions and Peel responses

Q1: Do you believe that CMP303 Original proposal better facilitates the Applicable CUSC Objectives?

Section 6 of the consultation sets out five applicable CUSC objectives and suggests that the CMP303 proposal has a positive impact on three of them, primarily related to cost reflectivity and

¹ Source: Baringa – Economic Opportunities of Renewable Energy for Scottish Island Communities.

² Source: Office of National Statistics, Regional and sub-regional productivity in the UK: Jan 2017

Peel Energy Ltd
Peel Dome
Intu Trafford Centre
TraffordCITY
Manchester
M17 8PL

t: 0161 629 8200
w: www.peelenergy.co.uk

A member of the Peel Holdings (Energy) group
Registered office: Peel Dome, Intu Trafford Centre, TraffordCITY, Manchester M17 8PL
Registered number: 07075301 England & Wales

promotion of competition. Two of the five are identified as not applicable. We agree with this assessment.

We consider the CMP303 original and alternatives improve the baseline CUSC in relation to promoting competition and increasing cost reflectivity whilst having no adverse impacts of significance. We do not believe the existing generator local circuit charging methodology as relates to HVAC subsea cables and HVDC reflects the wider transmission system benefits that are accrued by such works and are not required by the generators currently being asked to pay for them. We believe CMP303 correctly identifies this defect and is correct in examining solutions to it.

In relation to the current treatment of generator local circuit charges for HVAC subsea cables and HVDC we believe the CUSC is in defect by not recognising and accounting for the benefits accrued and not required by the generators using them. We therefore agree with CMP303 that costs associated with these additional benefits should be removed. We further note that these issues were debated during Project TransmiT and CMP213 but were not addressed at that time, Ofgem directing industry to address them at a later and more appropriate time which we consider is now.

Q2: Do you support the proposed implementation approach?

We support the implementation approach and timetable proposed, agreeing with the urgent need to establish an outcome ahead of the CfD auctions. The issue of charging is critical to the economics of our projects and other projects on the islands and it is virtually impossible to prepare a competent and competitive CfD bid without a decision on CMP303.

Our main concern with the CMP303 process is that it will be difficult to establish a clear answer in the proposed timescales.

Q3: Do you have any other comments?

We note the short timelines associated with this workgroup and have some concerns that there may be other benefits of HVAC subsea or HVDC links that have not yet been considered. Given the issues around timelines we are comfortable that the workgroup should progress as is but would seek assurance that further modifications in relation to other benefits could be raised at a later date.

Q4: Do you wish to raise a Workgroup Consultation Alternative request for the Workgroup to consider?

We do not wish to raise an alternative.

Q5: Do you consider that any or potential alternatives set out in Section 4 have merit? if so please provide your rationale.

We believe that the original proposal and all the alternatives 1 and 2 are relevant and have merit. We note that they fall into two broad categories related to demand (or import) provision, and the wider benefits of HVDC. Therefore, we believe that a combination, one from each category, should be taken.

In relation to the alternatives 1 and 1a, we are satisfied that both are suitable for use but would suggest further examples are examined to establish whether alternative 1 presents a consistently appropriate method. We also would welcome a National Grid ESO or transmission owner analysis of alternative 1a to provide a separate and validating view of the functionality and costs that are presented in Annex 3. We further note that alternative 1 would align the method with the

Peel Energy Ltd
Peel Dome
Intu Trafford Centre
TraffordCITY
Manchester
M17 8PL

t: 0161 629 8200
w: www.peelenergy.co.uk

A member of the Peel Holdings (Energy) group
Registered office: Peel Dome, Intu Trafford Centre, TraffordCITY, Manchester M17 8PL
Registered number: 07075301 England & Wales

normal onshore method where no substation costs are included and that this would additionally meet the Section 6 CUSC (e) objective of promoting efficiency in implementing the CUSC. We also note the alternative 1a proposer's comments that other HVDC functionality and costs could be included.

In relation to the original and alternatives 2, for Shetland, we favour alternative 2a since the costs of proving a demand supply to Shetland have already been clearly established through a competitive process. This provides a ready and clear path to quantify the adjustment that should be made in relation to demand security.

Q6: Do you consider that any or potential alternatives set out in Section 4 do not have merit? if so please provide your rationale.

As noted above, we consider that all alternatives have merit.

Q7: National Grid ESO have identified a number of potential implications associated with CMP303 which are set out in Appendix 3. Do you agree or disagree with this assessment? If so, please explain why.

We welcome the National Grid ESO analysis in Annex 3 and pages 9 and 10 of the consultation and note that it concludes there is no appreciable impact on consumers and the impact on other generators as just a small increase in the generator residual charge. From this it can be concluded that no adverse impacts are to be expected from improving the generator local circuit charging by modifying the current charging arrangements through CMP 303. We are happy and agree with this assessment.

Yours faithfully,



Daniel Badcock
Development Director
dbadcock@peellandp.co.uk | 0161 629 8216

CUSC Workgroup Consultation Response Proforma

CMP303 “Improving local circuit charge cost-reflectivity”

Industry parties are invited to respond to this consultation expressing their views and supplying the rationale for those views, particularly in respect of any specific questions detailed below.

Please send your responses by **22 January 2019** to cusc.team@nationalgrid.com. Please note that any responses received after the deadline or sent to a different email address may not receive due consideration by the Workgroup

These responses will be considered by the Workgroup at their next meeting at which members will also consider any Workgroup Consultation Alternative Requests. Where appropriate, the Workgroup will record your response and its consideration of it within the final Workgroup report which is submitted to the CUSC Modifications Panel.

Respondent:	<i>James Anderson</i> <i>James.anderson@scottishpower.com</i>
Company Name:	<i>ScottishPower Energy Management Limited</i>
Do you believe that the proposed original better facilitate the Applicable CUSC Objectives? Please include your reasoning.	<p><i>For reference, the Applicable CUSC Objectives for the Use of System Charging Methodology are:</i></p> <p><i>((a) That compliance with the use of system charging methodology facilitates effective competition in the generation and supply of electricity and (so far as is consistent therewith) facilitates competition in the sale, distribution and purchase of electricity;</i></p> <p><i>(b) That compliance with the use of system charging methodology results in charges which reflect, as far as is reasonably practicable, the costs (excluding any payments between transmission licensees which are made under and accordance with the STC) incurred by transmission licensees in their transmission businesses and which are compatible with standard licence condition C26 requirements of a connect and manage connection);</i></p> <p><i>(c) That, so far as is consistent with sub-paragraphs (a) and (b), the use of system charging methodology, as far as is reasonably practicable, properly takes account of the developments in transmission licensees’ transmission businesses;</i></p> <p><i>(d) Compliance with the Electricity Regulation and any relevant legally binding decision of the European Commission and/or the Agency. These are defined within the National Grid Electricity Transmission plc Licence under Standard Condition C10, paragraph 1*; and</i></p> <p><i>(e) Promoting efficiency in the implementation and administration of the CUSC arrangements.</i></p>

	<p>*Objective (d) refers specifically to European Regulation 2009/714/EC. Reference to the Agency is to the Agency for the Cooperation of Energy Regulators (ACER).</p>
	<p><i>The Proposal will better facilitate competition (Applicable Charging objective (a)) by ensuring a level playing field between generators connected using HVDC technology and generators connected using alternative technologies.</i></p> <p><i>By ensuring that costs which do not directly relate to the connection of a generator are excluded from the expansion factor for HVDC circuits, the Proposal will better reflect the incremental costs imposed on the network by that generator and better facilitate ACO (c).</i></p> <p><i>By reflecting the increasing use of HVDC technology on the GB transmission system the proposal will better facilitate ACO (c).</i></p> <p><i>The Proposal is neutral against ACOs (d) & (e) and overall better meets the Applicable Charging Objectives.</i></p>
<p>Do you support the proposed implementation approach? If not, please state why and provide an alternative suggestion where possible.</p>	<p><i>Recognising the interaction of CMP303 with the need to provide certainty to developers ahead of the 2019 Contract for differences auction (summer/autumn 2019) the Proposal should be implemented ahead of the CFD tender submission date if possible.</i></p>
<p>Do you have any other comments?</p>	<p><i>No.</i></p>
<p>Do you wish to raise a Workgroup Consultation Alternative request for the Workgroup to consider?</p>	<p><i>No.</i></p>

Specific questions for CMP303

Q	Question	Response
5	<p>Do you consider that any of the potential alternatives set out in Section 4 do not have merit? Please provide your rationale.</p>	<p><i>During the CMP213 development process, the issue of excluding HVDC converter costs from the expansion factor for HVDC circuits was proposed as a potential Alternative. At that time there was little evidence of actual costs or operational experience of HVDC technology. It is now appropriate to re-consider the costs to be included in the calculation of HVDC expansion factors and all of the options outlined in section 4 are worthy of further development and consideration by the CMP303 workgroup.</i></p>

Q	Question	Response
6	<p>Do you consider that any or potential alternatives set out in Section 4 do not have merit? if so please provide your rationale</p>	<p><i>See answer to question 5</i></p>
7	<p>National Grid ESO have identified a number of potential implications associated with CMP303 which are set out in Annexe 3. Do you agree or disagree with this assessment? If so, please explain why</p>	<p><i>The analysis provided by the ESO in Annexe 3 confirms the assumption that where the total amount recoverable from generators is capped by ER 838/2010 any reduction in the amount recovered through local circuit charges will result in an increase the amount recovered from all generators through the generator residual charge.</i></p> <p><i>This position may change under Ofgem's Targeted Charging Review which amongst other items proposes that TNuoS residual charges should only be recovered from "Final Demand" and that the "narrow" interpretation of Connection Charges in Ofgem's decision on CMP261 should be implemented.</i></p>

CUSC Workgroup Consultation Response Proforma

CMP303 “Improving local circuit charge cost-reflectivity”

Industry parties are invited to respond to this consultation expressing their views and supplying the rationale for those views, particularly in respect of any specific questions detailed below.

Please send your responses by **22 January 2019** to cusc.team@nationalgrid.com. Please note that any responses received after the deadline or sent to a different email address may not receive due consideration by the Workgroup

These responses will be considered by the Workgroup at their next meeting at which members will also consider any Workgroup Consultation Alternative Requests. Where appropriate, the Workgroup will record your response and its consideration of it within the final Workgroup report which is submitted to the CUSC Modifications Panel.

Respondent:	Eleanor Horn, eleanor.horn@nationalgrid.com , 07966 186088
Company Name:	National Grid ESO
Do you believe that the proposed original better facilitate the Applicable CUSC Objectives? Please include your reasoning.	<p><i>(a) That compliance with the use of system charging methodology facilitates effective competition in the generation and supply of electricity and (so far as is consistent therewith) facilitates competition in the sale, distribution and purchase of electricity;</i></p> <p>The umbrella of “facilitating competition” is broad. It is worth bearing in mind <i>why</i> facilitating competition is an important remit of the CUSC. Competition enables markets to function properly. Properly functioning markets are often considered to drive efficiencies; this should, in turn, provide consumer value.</p> <p>We feel that the consumer benefit from more effective competition from island projects in the CfD auctions is more uncertain than the cost to consumers from any residual pass through. Therefore, we would say that the proposed original has at best a negligible or more likely a small negative impact on end consumers - especially when considering the resourcing and system costs to the ESO and TOs of implementation which are also passed through to end consumers. However, we do believe it is an improvement on baseline CUSC in terms of facilitating competition by enabling island developers to participate more effectively.</p> <p><i>(b) That compliance with the use of system charging methodology results in charges which reflect, as far as is reasonably practicable, the costs (excluding any payments between transmission licensees which are made under and accordance with the STC) incurred by transmission licensees in their transmission businesses and which are compatible with standard licence condition C26 requirements of a connect and</i></p>

manage connection);

Socialising the costs apportioned to additional functionality would further reduce the cost reflectivity of transmission use of system charges. Whilst the developer of the island project may not strictly require the extra functionality, the connection would not be built at all had they not chosen to connect there. To then levy some of those costs across generation, no matter where they are located, further distorts the locational signal within TNUoS charges.

Additionally, the proposed original would bring the transmission charging methodology for islands further out of line with mainland connections. We are also concerned that should some costs be determined “not the responsibility” of the agent that originated the connection project there is the potential to create even greater complexity to the transmission charging methodology where the costs for every scheme (mainland or island) are divided differently.

This not only requires greater resourcing from the ESO and Transmission Owners which will be passed through to the end consumer but also make the charging arrangements more difficult to understand for inexperienced market participants.

Socialising more and more costs across all market participants undermines the principle of cost reflectivity and therefore we do not feel that the proposed original has merit under this CUSC objective.

(c) That, so far as is consistent with sub-paragraphs (a) and (b), the use of system charging methodology, as far as is reasonably practicable, properly takes account of the developments in transmission licensees’ transmission businesses;

Our feeling on this applicable CUSC objective is neutral.

The use of sub-sea AC or HVDC links is a relatively new development for the GB grid. It is important to think about how these assets should be treated in the charging methodologies. The proposed original could provide more clarity to project developers on how these costs are treated when compared to baseline CUSC however, should the changes from CMP301 be implemented the proposed original provides little else to support this CUSC objective as the required clarity is already provided.

(d) Compliance with the Electricity Regulation and any relevant legally binding decision of the European Commission and/or the Agency. These are defined within the National Grid Electricity Transmission plc Licence under Standard Condition C10, paragraph 1; and*

N/A

(e) Promoting efficiency in the implementation and administration

	<p><i>of the CUSC arrangements.</i></p> <p>The proposed original may reduce the efficiency of the CUSC arrangements should it set a precedent for users picking and choosing exactly what should be included in their local circuit tariff calculation.</p> <p>*Objective (d) refers specifically to European Regulation 2009/714/EC. Reference to the Agency is to the Agency for the Cooperation of Energy Regulators (ACER).</p>
<p>Do you support the proposed implementation approach? If not, please state why and provide an alternative suggestion where possible.</p>	<p>The implementation approach has not been fully developed by the proposer as we are waiting on the legal text to see how the proposer would recommend the TOs and NGENSO revenue teams share the required data.</p> <p>Our view is that CMP303 does facilitate competition when compared to baseline CUSC but significantly undermines the principle of cost-reflectivity. We have a broadly neutral stance on the other three objectives. Crucially, for us, the challenges surrounding the practical implementation of the proposed original mean that we don't believe it provides consumer value.</p> <p>Additionally, the workgroup did not provide compelling evidence that the practical implementation of this proposal would have a material impact. Whilst the TO may choose between a bi-directional or mono-directional cable, after making their economic and efficient assessment of network requirements, we did not establish if the costs for the two types of cable were significantly different.</p> <p>In summary, we wouldn't support this proposal as improving baseline CUSC without understanding the implementation approach in more detail. Our view is that the proposed original could have merit providing the implementation approach requires that the TO has made an unequivocal decision to procure additional functionality above and beyond the users connection requirements and that they can provide two clear costs related directly to the actual project in question to establish the costs to be reapportioned away from the local circuit tariff.</p>
<p>Do you have any other comments?</p>	<p>During workgroup discussions, the workgroup established that the TO could discuss their functional requirements with vendors (an example being bi-directionality) but that the vendor may come back with "one solution and one price". The proposed original suggests that the additional cost (cost for TO choice – cost for user requirement) be removed from the applicable costs that are fed into the transport model to generate local circuit tariff prices. How would the proposer envisage the modification being practically implemented in a situation such as this where the TO doesn't have two clear prices for the different levels of functionality?</p>

Do you wish to raise a Workgroup Consultation Alternative request for the Workgroup to consider?	No
--	----

Specific questions for CMP303

Q	Question	Response
5	Do you consider that any of the potential alternatives set out in Section 4 do not have merit? Please provide your rationale.	<p>We believe that the alternatives are within the scope of the defect however we don't feel that we have enough detail to fully establish whether they have merit.</p> <p>Our first thoughts are to raise a concern around the reliance on <u>estimating</u> perceived benefits/costs. The estimating methodologies propose using figures from other schemes. There is a risk that too much of the project cost is socialised. We feel that this seriously undermines the principle of cost reflectivity and will have a negative impact on consumers.</p>
6	Do you consider that any or potential alternatives set out in Section 4 do not have merit? if so please provide your rationale	N/A
7	National Grid ESO have identified a number of potential implications associated with CMP303 which are set out in Appendix 3. Do you agree or disagree with this assessment? If so, please explain why	As the provider of the analysis we believe it to be accurate based on the available data and the agreed assumptions/parameters. As is clarified in the workgroup report the NGESO analysis was produced before we knew the outcome of the TCR and so the outputs will most likely now be different. Greater detail from the TCR will be known by June 2019 and the analysis could be reassessed however this is outside the timescales preferred by the workgroup.

CUSC Workgroup Consultation Response Proforma

CMP303 “Improving local circuit charge cost-reflectivity”

Industry parties are invited to respond to this consultation expressing their views and supplying the rationale for those views, particularly in respect of any specific questions detailed below.

Please send your responses by **22 January 2019** to cusc.team@nationalgrid.com. Please note that any responses received after the deadline or sent to a different email address may not receive due consideration by the Workgroup

These responses will be considered by the Workgroup at their next meeting at which members will also consider any Workgroup Consultation Alternative Requests. Where appropriate, the Workgroup will record your response and its consideration of it within the final Workgroup report which is submitted to the CUSC Modifications Panel.

Respondent:	<p><i>Please insert your name and contact details (phone number or email address)</i></p> <p>Michael Ferguson - michael.ferguson@sse.com, 07876 837 081 / Simon Redfern - simon.redfern@sse.com, 07881 343 355</p>
Company Name:	<p><i>Please insert Company Name</i></p> <p>Scottish Hydro Electric Power Distribution plc (CUSC party / signatory)</p>
Do you believe that the proposed original better facilitate the Applicable CUSC Objectives? Please include your reasoning.	<p><i>For reference, the Applicable CUSC Objectives for the Use of System Charging Methodology are:</i></p> <p><i>((a) That compliance with the use of system charging methodology facilitates effective competition in the generation and supply of electricity and (so far as is consistent therewith) facilitates competition in the sale, distribution and purchase of electricity;</i></p> <p><i>(b) That compliance with the use of system charging methodology results in charges which reflect, as far as is reasonably practicable, the costs (excluding any payments between transmission licensees which are made under and accordance with the STC) incurred by transmission licensees in their transmission businesses and which are compatible with standard licence condition C26 requirements of a connect and manage connection);</i></p> <p><i>(c) That, so far as is consistent with sub-paragraphs (a) and (b), the use of system charging methodology, as far as is reasonably practicable, properly takes account of the developments in transmission licensees’ transmission businesses;</i></p> <p><i>(d) Compliance with the Electricity Regulation and any relevant legally binding decision of the European Commission and/or the Agency. These are defined within the National Grid Electricity</i></p>

*Transmission plc Licence under Standard Condition C10, paragraph 1**; and

(e) Promoting efficiency in the implementation and administration of the CUSC arrangements.

*Objective (d) refers specifically to European Regulation 2009/714/EC. Reference to the Agency is to the Agency for the Cooperation of Energy Regulators (ACER).

We consider that charging for HVDC links should be cost reflective, with potential for customer / DSO / NGESO contributions towards costs where justified. We consider that this arrangement better enables objective (a) in more effectively facilitating competition in the generation and supply of electricity.

The CMP 303 proposals better facilitate objective (b) as the charges continue to reflect the costs incurred by transmission licensees, but lead to these costs being shared more equitably among relevant parties who benefit from shared use of a given asset.

We consider that charging for HVDC links should be cost reflective, with mechanisms for customer / DSO / NGESO contributions towards costs, where justified. We consider that the core recommended proposal and several of the alternative proposals set out in CMP 303 align to a degree with “whole system” *principles* of cost- and benefit-sharing, which have been set out by Ofgem and supported by stakeholders as an integral part of an efficient system¹, and as such go some way towards facilitating objective (c). However we consider that several of the alternatives do not go far enough in aligning with these principles, as set out below.

The CMP 303 proposals identify two broad principles for achieving cost-reflectivity: i) the identification and carve-out of relevant transmission asset / equipment costs such as converter and bidirectionality costs from TNUoS charges, where it is determined that these assets are not required, or are not required in entirety, by generators; and ii) the application of a value for the provision of supply / services from an HVDC system such as “making supply” to an island distribution system, also applied to reduce TNUoS charges.

With regards to i) the core recommended proposal of CMP 303 identifies the requirement to carve out “extra costs” of “additional functionality” which are “unrelated from the generators needs” from the costs borne by the generators who have requested associated transmission links. It is proposed that costs relating to

¹ [Ofgem Consultation on licence conditions and Guidance for network operators to support an efficient, coordinated and economical Whole System](#), December 2019

the function of bidirectionality are removed at a minimum. We agree with cost-sharing, cost-reflective charging in principle, and that a customer should not be faced with undue costs which are unrelated to the service it requires, and it is for the TO, NGENSO, generators and Ofgem to determine specific arrangements.

With regards to ii) (which it may be appropriate to apply in addition to i)) where it is established that a third party may benefit from an HVDC system, we recommend that it is for the relevant customer (e.g. DSO / NGENSO) to determine its need, and to make a valuation of the relevant assets / services which would be used by / of benefit to those customers in meeting that need. There should also be a correct allocation of cost, applied towards those customers. We believe this better aligns with whole system objectives, which are envisaged to see “network operators...identify and pursue solutions that can benefit multiple parties across the system”, with “...Parties contributing efficient costs to reflect the benefits they receive in delivering their obligations and outputs”.² We consider that modifications / clarifications to CMP 303 proposals to this effect would more closely align with whole system principles and would better facilitate objective (c) than the current CMP 303 proposals. **All of SHEPD’s views hereafter set principle i) to one side, as subject to determination by other parties, and are made in relation to principle ii) only.**

SHEPD has been developing proposals for an enduring solution for Shetland over the past several years, in the context of its distribution licence obligation. SHEPD has over the past year carried out detailed analysis and has developed comprehensive methodologies with independent industry consultants which i) identify island distribution system need, ii) identify and value avoided cost benchmarks, iii) value services from a transmission link to a distribution system and iv) identify how a contribution made by the DSO for the benefit of distribution consumers would be paid for by those consumers. SHEPD has also progressed proposals, with BEIS and Ofgem, around how relevant costs would be recovered from distribution or GB customers.

These proposals have been under review by Ofgem in the course of 2018, and assessed in detail since SHEPD’s formal submission to Ofgem in November 2018. Ofgem has indicated its intention to consult on its position and SHEPD’s recommendation on an island contribution methodology in March 2019, with the intent to reach a decision before the expected launch of the 2019 CfD auction, which is expected in May 2019. SHEPD’s methodologies and proposed contribution values would be shared for stakeholder assessment and feedback at

² [Ofgem consultation on licence conditions and Guidance for network operators to support an efficient, coordinated, and economical Whole System](#), p.6-7

	<p>this point.</p> <p>We recommend that the CMP 303 proposals are further articulated and implemented in such a way as to clearly define the role and involvement of the relevant customer in identifying its need and its contribution towards costs for shared use of an asset. In the cases of HVDC transmission links to Shetland and the Western Isles, this customer would be SHEPD (and potentially also NGESO, and perhaps others), and we suggest SHEPD’s methodologies should determine the contribution for meeting distribution system needs.</p> <p>Finally, it is not clear to us how the proposed allocation of costs relating to “additional functionality” to the generation residual tariff meets either the Applicable CUSC Objectives or the underpinning rationale set out in the CMP 303 consultation, given that the UK generator base will not benefit from this functionality. In its DSO recommendation SHEPD has proposed that, as services of value to the distribution system, relevant contribution costs are targeted towards those customers (through either DUoS or, for Shetland, the Hydro Benefit Replacement Scheme).</p> <p>We have not commented on objectives (d) and (e).</p>
<p>Do you support the proposed implementation approach? If not, please state why and provide an alternative suggestion where possible.</p>	<p>We agree with the urgency of the implementation timing, driven by the impending CfD auction, and the imperative that developers must have clarity on TNUoS charges ahead of this, noted in section 7.</p>
<p>Do you have any other comments?</p>	<p>SHEPD supports the principles of cost reflectivity outlined in CMP 303, and notes its view that these are best achieved not only by carving out costs identified as relating to bidirectionality, as in CMP 303’s core proposal, but also by reflecting the value an HVDC transmission link brings to users. We have developed methodologies which propose this for distribution customers on the Scottish islands. We recommend that CMP 303 is modified to clearly define the role of the customer(s) who would benefit from shared use of an asset to define the scale / nature of its need for such an asset, and the value it places on this.</p> <p>We have included this approach as an alternative proposal, but propose that it should also be incorporated into any CMP 303 proposals taken forward which identify the DSO as a potential customer, by further articulating and clearly defining the role and involvement of the relevant customer (e.g. the DSO) in identifying its need and its contribution towards costs for shared use of an asset. There is the clear direction of travel set out in the developing whole systems</p>

workstreams which, as referred to earlier in our response, are envisaged to see “network operators...identify and pursue solutions that can benefit multiple parties across the system”, with “...Parties contributing efficient costs to reflect the benefits they receive in delivering their obligations and outputs”.³ It is not clear how networks may deliver whole systems efficient outcomes if they are not permitted to be actively involved in specifying, and contributing towards solutions. We have submitted SHEPD’s proposals as an alternative which may be progressed in combination with other proposals (e.g. 4(b)), but which also should be taken forward as an amendment to any existing proposals which are progressed which involve the principle of a contribution by the DSO towards a transmission link..

SHEPD welcomes the Workgroup Consultation on CMP 303, and has reviewed it with great interest. The general philosophy of different users of an asset contributing towards its cost is one which underpins SHEPD’s Distribution System Operator (DSO) Contribution workstream which has been in development since early 2018, and our associated recommendation to Ofgem made in November 2018. SHEPD has responsibility, defined in its electricity distribution licence, for identifying and delivering an enduring solution to meet the needs of the distribution system on the Shetland Islands. SHEPD has associated cost recovery arrangements to provide for its efficient expenditure in meeting this obligation. Shetland is the only specific island location for which SHEPD has this kind of licence obligation, reflecting the materiality and urgency of the need of the distribution system, which is the only remaining island with no existing mainland connection.

SHEPD DSO Contribution Recommendation

Since early 2018 SHEPD has, with leading industry consultants, undertaken a workstream to:

1. update its view on benchmark costs of a range of alternative means of meeting distribution system needs, including reviewing those solutions / costs identified through an open market tender process in 2017 (including the proposed 60MW distribution link);
2. develop first-of-a-kind methodologies which value the services which would be provided by a mainland transmission link to the Shetland distribution system (reflecting on the third party proposals for a transmission link to be progressed, and recognising that a link could meet

³ [Consultation on licence conditions and Guidance for network operators to support an efficient, coordinated, and economical Whole System](#), December 2018 p.6-7,

distribution system needs);

3. analyse and compare the costs and benefits of these services against those of the benchmarked costs of alternative means of meeting distribution system needs; and to
4. identify how a contribution made by the DSO for the benefit of distribution consumers would be paid for by those consumers.

This workstream culminated in a recommendation to Ofgem which sets out:

1. a methodology to determine the expected cost to meet distribution system needs if a future tender was run, defined as the “avoided cost” value (for the specific Shetland case being £400m – not £279m as indicated in the CMP 303 consultation);
2. a methodology which calculates a value of a contribution towards a transmission asset based on analysis of the services that it could provide, defined as the “fair value” contribution (we have defined a fair value for the Shetland case which we have provided to Ofgem in our recommendation, which is proposed to be consulted on shortly); and
3. a mechanism by which a contribution may be made, proposing that any contribution is netted off by the relevant TO in its calculation of local circuit costs, before these are confirmed to NGENSO and become part of TNUoS charges.
4. Finally, SHEPD proposes that a contribution made by the DSO for the benefit of distribution consumers would be paid for by those consumers. SHEPD has proposed to Ofgem that this is best achieved by a direct contribution to the cost of the new asset by the DSO. This is akin to investing in a solution, directs costs to the distribution customers who benefit and are recovered in a way that is consistent with the RIIO allowed revenue structure. It is also very similar to the contribution of connecting parties to their connection assets.

We note that we have shared the analysis on and value of the proposed Shetland fair value contribution with Ofgem, and would propose to share this with the Panel at a later date. We note that Ofgem has said its intent is to consult on SHEPD’s contribution approach and to reach a conclusion on value before the 2019 CfD auction.

As such, there are notable parallels between SHEPD’s recommendation and some of the principles of approach set out in the proposed CMP 303 modification.

However, there are also several key areas of divergence.

Specifically:

1. SHEPD recommends that it is for the relevant customer (e.g.

DSO / NGESO) to determine its need, and to make a valuation of the avoided costs or “fair value” of relevant assets / services which would be used by / of benefit to those customers in meeting that need, and not for one value to be applied in all cases as is proposed by alternatives 2(a) and 4(a). There should also be a correct allocation of cost, applied towards those customers who benefit. We consider that modifications / clarifications to CMP 303 proposals to this effect would more closely align with whole system principles; and

2. SHEPD’s recommendation to Ofgem proposes that a “fair value” contribution is made towards a link, a step further than applying the “avoided cost” of alternative means of meeting the need. The fair value contribution is based on SHEPD’s assessment of the value of services and identification of a cost saving for consumers against the avoided cost value. This is a first-of-a-kind, “whole system” approach. Several of the CMP 303 alternatives propose that the whole avoided cost – the cost of alternative means of meeting the need - is carved out of the transmission capital costs. We agree that it is reasonable to assume that the cost avoided for a given group of consumers represents the maximum value of a contribution towards a shared-use transmission link. As noted, both the Shetland avoided cost and fair value contribution methodologies and values are expected to be consulted on shortly.

SHEPD’s workstream has focused primarily on the Shetland arrangements, reflecting the fact that there is an urgent need to secure a security of supply solution. However SHEPD’s contribution methodologies may be applied elsewhere, adapted on a case by case basis in order to ensure proportionality and cost efficiency.

In summary, our position is that we recommend that the value of a transmission asset to other customers / users is determined and applied on the basis of a case by case assessment of need and valuation of use of a given asset / services by those customers, and that it would be reasonable that the “avoided cost” of meeting that need by other means need would represent the maximum contribution those customers would be likely to make.

Summary of areas of alignment and divergence

These views are expressed **in principle** - SHEPD detailed comments to be taken into account in relation to specific proposals.

CMP 303 principle	Alignment / Divergence	SHEPD DSO contribution methodology principle
Customer should not be targeted with undue cost which is unrelated to service required (core proposal)	✓ Alignment	Contributions may be proposed where assets / services meet specific needs of distribution system/ customer
Different users of a shared asset should contribute towards its cost (core and alternative proposals)	✓ Alignment	As above
User contributions towards cost should be applied and reflected in charging arrangements (core and alternative proposals)	✓ Alignment	Contributions are applied towards capital costs of asset
Supply offset based on NES 2017 value applied consistently to all islands (alternatives 2a, 4a)	✗ Divergence	Contribution towards cost based on determination of need and value of services, defined by recipient customer
Attribution of excess cost to generation residual (passive)	✗ Divergence	Contribution actively defined and made by proactive recipient customer base (e.g. DSO / demand)

Clarifications on SHEPD NES and DSO contribution processes

CMP 303 makes the following statement:

“The cost of the HVDC part of the solution was £279m if a transmission link is built to Shetland to enable generation exports, the bi-directional transmission link will also provide a supply to the island to replace the power station with a capital saving of £279m.”

We note the following:

- The CMP 303 proposals make an error in assuming that security of supply for Shetland in the NES process was to be secured by the HVDC link. This is not the case, as the security of supply is provided by the back-up power station and the link just provides cheaper (and potentially cleaner) energy.

- In some parts CMP 303 references the NES solution as a transmission link - this is incorrect. The recommended solution, on the basis of meeting the tender's technical and security of supply requirements, and subsequently being the most cost efficient offering, was a 60MW distribution link.
- The HVDC part of the proposed NES link solution was not £279m. This £279m value was the capital cost for the construction of the link including the 132kV and 33kV connections at each end, and does not include any margin for profit or risk, which would be expected to be built in by any provider bidding to provide such as asset in a commercial process. This was also not a tendered or evaluated cost, as the tenders were made on the basis of Availability and Output / Utilisation charges. –This value represents Ofgem's interpretation of the capital cost of the tendered solution extracted from the tenderer's financial model. Therefore it is our view that this "avoided cost" value should be higher, as no party will offer such as asset at cost. As set out above, SHEPD and Baringa Partners have identified this value as c.£400m.
- The HVDC link proposed in the NES was not specified or tendered as bidirectional. The tender procured a Shetland supply solution only, and export capability was not specified, valued or procured.
- It is claimed in the CMP 303 consultation that the Shetland competition proves that HVDC is cheaper than AC. It is not possible to make this assumption on the basis of the NES process, as no AC link was offered.
- Several of the CMP 303 alternatives assume that the whole avoided cost is carved out of the transmission capital costs. We consider it is reasonable to assume that the avoided cost to a given group of consumers is the maximum value to consumers who would have shared use of a transmission link.
- In using the cost of the NES distribution link as the avoided cost, CMP 303 ignores the additional costs of connecting the distribution system to the HVDC network and the ongoing operational costs.

The role of the customer, and cost versus value

A key distinction between the CMP 303 proposals as currently drafted (particularly 2(a), 2(b), 4(a) and 4(b)) and SHEPD's recommendation is who has responsibility to determine the need for, and identifies the value of avoided cost or of services provided by a transmission asset to a given recipient consumer, such as the DSO / distribution system. CMP 303's proposals in their current forms appear to determine the net-off amount as a fixed value derived from Ofgem's 2017 assessment of capex costs of a distribution link (alternative 2(a)). We understand why this approach has been taken, but consider that adopting these assumptions without reference to the DSO resigns the end

	<p>consumer, e.g. the distribution system, to a passive role, as if uninterested in the assets or services in question. We consider that need and value should be determined by the recipient consumer.</p> <p>SHEPD's methodologies identify the cost which could reasonably be expected to be incurred in procuring a new solution from the market, and subsequently define its view on the value of services which could be procured from a transmission asset.</p> <p>Finally, we believe that the proposed legal text set out on page 20 is open to interpretation and would benefit from further clarification, probably best achieved collaboratively with relevant stakeholders.</p>
<p>Do you wish to raise a Workgroup Consultation Alternative request for the Workgroup to consider?</p>	<p>As set out above, SHEPD recommends that it is for the relevant customer (e.g. DSO / NGESO) to determine its need, and to make a valuation of the avoided costs and / or "fair value" of relevant assets / services which would be used by / of benefit to those customers in meeting that need. There should also be a correct allocation of cost, applied towards those customers who benefit.</p> <p>We note our view that for any of the alternatives where there is an attempt made to reflect the benefit or value of an asset and / or other services to other customers / users, it is for those parties who will benefit from the shared use of the asset and / or associated services to determine both i) the scale and nature of the need that those parties have, and ii) the value that they place on associated assets or services. We disagree with any methodology which assumes the same level of need and application of the same valuation of benefits across all island situations. This would fail to take proper account of need, and would be highly unlikely to result in a cost efficient or cost reflective outcome. We therefore strongly recommend that CMP 303 is modified to incorporate this process of engagement with, and determination of need by, relevant parties.</p> <p>SHEPD, as a potential future user of island transmission links, has identified its needs in relation to these distribution systems. Subject to Ofgem's approval, our avoided costs / fair value contribution methodologies have been proposed for Shetland, and associated proposals for the Western Isles are currently under assessment. As such, in the case of the Scottish islands which are the focus of current transmission link developments, SHEPD's contribution methodology may, subject to consultation and Ofgem review, be utilised to determine the need for, and value of, DSO / distribution contributions towards transmission costs.</p> <p>We have submitted SHEPD's proposals as an alternative which</p>

may be progressed in combination with other proposals (e.g. 4(b)), but which also should be taken forward as an amendment to any existing proposals which are progressed which involve the principle of a contribution by the DSO towards a transmission link.

Specific questions for CMP303

Q	Question	Response
5	<p>Do you consider that any of the potential alternatives set out in Section 4 do not have merit? Please provide your rationale.</p>	<p>We note that this question appears to have been written incorrectly in the template – we are responding to Q5 as set out in the consultation document which asks, “Do you consider that any or potential alternatives set out in Section 4 have merit? if so please provide your rationale” (CMP 303 consultation document p.17).</p> <p>Alternative 1 proposes the removal of converter station costs from HVDC charging. As set out elsewhere in our response, SHEPD supports the principles of cost reflectivity outlined in CMP 303, and that a customer should not be targeted with undue cost which is unrelated to the service it requires. We agree with these principles of cost-reflectivity. We consider that it is for the TO, NGENSO, generators and Ofgem to determine specific arrangements which specify the technical requirements of a given transmission development and identify the “additional functionality” of specific assets.</p> <p>Alternative 1a essentially values the services provided by the HVDC link to the distribution network. It is similar in principle to that proposed in SHEPD’s fair value test methodology, but looks more widely to carve out the costs of specific assets which provide associated system benefits, whereas the fair value test considers the value to the island DSO. Alternative 1(a) is not articulated in enough detail to confirm a definitive view. We agree in general with the principles of cost-reflectivity. We would note that, as above, SHEPD considers that it is for the TO, NGENSO, generators and Ofgem to determine such arrangements for specific assets. We note that the consultation document does not clearly conclude whether associated assets are needed by generators or not.</p> <p>Alternative 2(b) is close to the avoided costs assessment included within the DSO recommendation, which defines the benchmarked level of avoided costs from the 2017 NES process (see our explanation of this process under the “Other comments” section, above),</p>

Q	Question	Response
		<p>and we broadly support it in principle. However, it does not reflect additional costs that would arise when procuring a link through a competitive tender, such as for profit and risk, or the costs of connection and adaptation of the distribution network to an HVDC supply (again, see our narrative under “Other comments”). SHEPD’s recommendation identifies both a higher avoided costs value of £400m, and a “fair value” for services from a transmission link.</p> <p>Alternatives 4(a) and (b) appear to be combinations of alternatives 1 and 2. We agree with the principles of cost-reflectivity, and agree that an additive approach may be appropriate– we suggest that a mechanism is required which identifies a maximum value of additive alternatives to ensure this remains cost efficient and fair.</p>
6	<p>Do you consider that any or potential alternatives set out in Section 4 do not have merit? if so please provide your rationale</p>	<p>With reference to alternative 2(a) (and mirrored in 4(a)), the CMP 303 consultation makes the following statement (p.13):</p> <p><i>“The same principle of security of supply would apply to other remote islands, and as cost saving information is not to hand for these islands therefore the same percentage cost reduction for transmission charging purposes should be applied to other remote islands, as with HVDC links for Shetland.”</i></p> <p>We do not agree with this position. Avoided costs for the Western Isles can and are being assessed by SHEPD. Taking account of existing network and generation infrastructure, it is clear that the value to consumers of a transmission connection to the Western Isles is an order of magnitude smaller than for Shetland. This is a result of the geography of the islands, the historical additional investment those island networks have received, and the timing of the need to replace the current Shetland solution. It does not seem reasonable to assume that Shetland is an appropriate benchmark for the value of other HVDC links.</p> <p>SHEPD’s recommendation identified both an updated avoided costs value of £400m, and a proposed methodology and value for services from a transmission link.</p> <p>SHEPD considered the same approach identified under alternative 2(c) as part of its fair value test methodology, but rejected this on the basis that the value of the link to the distribution system is not</p>

Q	Question	Response
		<p>proportional to the energy flows, but to the proportion of the time that the distribution system relies on the link for import of energy to meet demand. We would be interested in further justification of this proposal.</p> <p>The consultation notes that alternative proposals 3 and 5 are discontinued and not formally submitted. SHEPD has ignored these proposals as they reflect on a far-reaching tariff change, which is outside the scope of the DSO workstream.</p>
7	<p>National Grid ESO have identified a number of potential implications associated with CMP303 which are set out in Appendix 3. Do you agree or disagree with this assessment? If so, please explain why</p>	<p>It is not clear to us how the proposed allocation of costs relating to “additional functionality” to the generation residual tariff meets either the Applicable CUSC Objectives or the underpinning rationale set out in the CMP 303 consultation, given that the UK generator base will not benefit from this functionality. In its DSO recommendation SHEPD has proposed that, as services of value to the distribution system, costs are targeted towards those customers (through either DUoS or, for Shetland, the Hydro Benefit Replacement Scheme).</p>

CUSC Workgroup Consultation Response Proforma

CMP303 “Improving local circuit charge cost-reflectivity”

Industry parties are invited to respond to this consultation expressing their views and supplying the rationale for those views, particularly in respect of any specific questions detailed below.

Please send your responses by **22 January 2019** to cusc.team@nationalgrid.com. Please note that any responses received after the deadline or sent to a different email address may not receive due consideration by the Workgroup

These responses will be considered by the Workgroup at their next meeting at which members will also consider any Workgroup Consultation Alternative Requests. Where appropriate, the Workgroup will record your response and its consideration of it within the final Workgroup report which is submitted to the CUSC Modifications Panel.

Respondent:	<i>Garth Graham (garth.graham@sse.com)</i>
Company Name:	<i>SSE Generation Ltd</i>
Do you believe that the proposed original better facilitate the Applicable CUSC Objectives? Please include your reasoning.	<p><i>For reference, the Applicable CUSC Objectives for the Use of System Charging Methodology are:</i></p> <p><i>((a) That compliance with the use of system charging methodology facilitates effective competition in the generation and supply of electricity and (so far as is consistent therewith) facilitates competition in the sale, distribution and purchase of electricity;</i></p> <p>We believe that CMP303 Original will better facilitate this applicable objective by ensure that as market participants pay more cost reflective charges that they are able to compete more effectively in the generation and supply of electricity.</p> <p><i>(b) That compliance with the use of system charging methodology results in charges which reflect, as far as is reasonably practicable, the costs (excluding any payments between transmission licensees which are made under and accordance with the STC) incurred by transmission licensees in their transmission businesses and which are compatible with standard licence condition C26 requirements of a connect and manage connection);</i></p> <p>We believe that the Original is clearly better in terms of facilitating this applicable objective. This is because, as the Proposer has set out in the proposal and the Workgroup has examined, there are additional costs associated with making an HVDC link (and the associated onshore TO works) bi-directional</p>

	<p>that is over and above the costs that would have arisen had the link been only mono-directional.</p> <p>There are clearly wider benefits for demand users (and network operators?) of having a bi-directional functionality for the HVDC link itself along with the associated onshore TO (and / or DNO?) works.</p> <p>However, it is inappropriate, in terms of cost reflectivity, to recover these additional costs (from having bi-directionality) not from the parties that (i) give rise to it and/or (ii) benefit from the additional functionality (namely Demand) but, instead recover it from the generator(s) alone via the local circuit charge.</p> <p><i>(c) That, so far as is consistent with sub-paragraphs (a) and (b), the use of system charging methodology, as far as is reasonably practicable, properly takes account of the developments in transmission licensees' transmission businesses;</i></p> <p>The Original is better in terms of facilitating this applicable objective as it takes account of developments in the transmission system which is seeing the application of HVDC technology to island situations; namely the connection of generation from a number of the Scottish island groups to the NETS. As this recent development in the transmission business is being taken on board; by network operators, generators, the Regulator and end consumers; it is appropriate, at this time, that the CUSC charging methodology is updated reflect this recent development in a way that is better in terms of cost reflectivity and effective competition in generation and supply of electricity.</p> <p><i>(d) Compliance with the Electricity Regulation and any relevant legally binding decision of the European Commission and/or the Agency. These are defined within the National Grid Electricity Transmission plc Licence under Standard Condition C10, paragraph 1*; and</i></p> <p>We believe that the Original is neutral in terms of this applicable objective.</p> <p><i>(e) Promoting efficiency in the implementation and administration of the CUSC arrangements.</i></p> <p>We believe that the Original is neutral in terms of this applicable objective.</p>
<p>Do you support the proposed implementation approach? If not, please state why and provide an alternative suggestion where possible.</p>	<p>We note the proposed implementation approach set out in Section 7 of the Workgroup consultation and we support that proposed approach. We would, in particular, wish to emphasis the imminent date related issue, namely the forthcoming CfD auction (the date for which is set by the Secretary of State).</p>

	<p>In this regard, it is vital that an Authority decision is given at least ten working days ahead of the auction closing date to allow participants in the auction sufficient time to factor in the Authority decision (in terms of its impact on TNUoS, and local circuit charges in particular) when they are providing prices into that auction.</p>
<p>Do you have any other comments?</p>	<p>We note the Workgroup deliberations in terms of Potential Alternative 1 and are mindful of the deliberations of the CMP213 Workgroup¹ in this areas which identified that certain elements within the DC Converter Station (rather than all the elements of the DC Converter Station) are akin to the onshore AC transmission infrastructure, such as (AC) sub stations, the cost of which is recovered (cost reflectively) on a non-locational basis.</p> <p>For the avoidance of doubt, it is our understand that this is also the intention for Potential Alternative 1 – namely (in addition to the bi-directionality set out in CMP303 Original) that some, but not all, of the DC Converter Station costs (those akin to the onshore AC transmission infrastructure) would be recovered on a non-locational basis, with the balance of the DC Converter Station costs being recovered (in terms of generators) via, in the example of the Scottish islands, the local circuit charge.</p> <p>Based on the CMP213 analysis this suggest, in the context of Potential Alternative 1, “that approximately half of the basic cost elements of the HVDC converter station have characteristics equivalent to AC and the other half to DC”.</p> <p>Therefore, if one assumes that circa half the total cost of a HVDC link consists of the cost of the (two) converter stations and the remaining half is the cost of the cable(s) then approximately a quarter of the total cost of the HVDC link cost would be recovered on a non-locational basis and the remaining three quarters would be recovered on a locational basis.</p>
<p>Do you wish to raise a Workgroup Consultation Alternative request for the Workgroup to consider?</p>	<p>No.</p>

Specific questions for CMP303

¹ See, for example, para 5.27 of the CMP213 FMR
“After the Workgroup consultation, a paper was circulated to provide further information and justification around this potential alternative area. This can be found in Annex 14.4. This included further evidence reinforcing the validity of the Cigre cost breakdown provided prior to consultation (that approximately half of the basic cost elements of the HVDC converter station have characteristics equivalent to AC and the other half to DC), including confirmation from a technology supplier that the breakdown is representative of current converter technologies. It also highlighted that under turnkey contracting arrangements, specific cost details are difficult to obtain and so this supports a generic approach.”

Q	Question	Response
---	----------	----------

Q	Question	Response
5	<p>Do you consider that any of the potential alternatives set out in Section 4 do not have merit? Please provide your rationale. [we not the error above, and have based our answer on the version of Q5 shown on page 17]</p>	<p>We have considered the various potential alternatives set out on pages 13-17 of the Workgroup consultation.</p> <p>In our view the following <u>do have merit</u>.</p> <p>Potential Alternative 1 The work of the CMP213 Workgroup and the external analysis provided by CIGRE (linked to our answer to Q3 above) together with the CMP303 Workgroup deliberations on page 14, lead us to believe that there is merit (on the primary grounds of improving cost reflectivity) in this potential alternative. Thus the cost reallocation (from local circuit charges to the wider charging element of TNUoS) is equivalent to those elements of HVDC that are akin to the wider network costs being recovered in a similar way.</p> <p>Potential Alternative 2(b) Taking into account the information on pages 14-15 we believe that this potential alternative has merit as it is more cost reflective to apply, on a case by case basis, any offsetting saving in costs that could be warranted by avoiding the need to build a Distribution rated link by virtue of building a Transmission rated HVDC link instead.</p> <p>Potential Alternative 2(c) Taking into account the information on pages 15-16 we believe that this potential alternative may possibly have some merit in certain circumstances.</p> <p>Potential Alternative 4(b) Taking into account the information on pages 13-17 we believe that this potential alternative does have merit as it combines Potential Alternative 1 with Potential Alternative 2(b) which, as we have noted above, both have merit, as standalone Potential Alternatives, and when combined with the other exhibit the merits of their constituent parts (which we have set out above).</p> <p>In the context of Potential Alternative 2(b) it is important to note that the cost offset (or avoided) arising from not building a distribution link (to meet the needs of Demand, not Generation, on the island) is correctly recovered from Demand via DUoS as it is Demand (not Generation) that receives the benefit of this avoided cost (of not building a Distribution link because a Transmission link is built instead). In terms of Potential Alternative 4(b) then, as it combines 1 and 2(b), those respective cost approaches, combined, should apply to 4(b) as well.</p>

Q	Question	Response
6	<p>Do you consider that any or potential alternatives set out in Section 4 do not have merit? if so please provide your rationale</p>	<p>We have considered the various potential alternatives set out on pages 13-17 of the Workgroup consultation.</p> <p>In our view the following <u>do not have merit</u>.</p> <p>Potential Alternative 2(a) Taking into account the information on pages 14-15 we believe that this potential alternative does not have merit. This is because it is less cost reflective to apply a cost that has been derived for a particular HVDC link (such as for Shetland) to other HVDC links (such as that for the Western Isles) especially where the information needed to produce the 'generic' percentage should also be available, on a case by case basis, to allow for the actual relevant percentage figure to be calculated for each HVDC link.</p> <p>Potential Alternative 3 Taking into account the information on page 16 we believe that this potential alternative does not have merit. This is because, like Potential Alternative 2(a), it applies a single generic expansion factor across GB when it is possible (as we have now) to have more cost reflective expansion factors for the various categories of items that form the current expansion factors.</p> <p>Potential Alternative 4(a) Taking into account the information on pages 13-17 we believe that this potential alternative does not have merit. We note it combines Potential Alternative 1 (which has merit) with Potential Alternative 2(a) which, as we have noted above, does not have merit. When combined the 'dis-merit' of 2(a) is <u>not</u> outweighed by the merit of Potential Alternative 1.</p> <p>Potential Alternative 5 Taking into account the information on pages 13-17 we believe that this potential alternative does not have merit. We note it combines Potential Alternative 2 (of which 2(b) and possibly 2(c) have merit) with Potential Alternative 3 which, as we have noted above, does not have merit. When combined the 'dis-merit' of 3 is <u>not</u> outweighed by the merit of Potential Alternative 2(b) (and possibly 2(c)) for the reasons noted in Q5 above.</p>

Q	Question	Response
7	<p>National Grid ESO have identified a number of potential implications associated with CMP303 which are set out in Appendix 3. Do you agree or disagree with this assessment? If so, please explain why</p>	<p>We have considered the information contained in Appendix 3 from the ESO.</p> <p>In respect of the potential implications we note that the ESO appears to have undertaken their analysis on the basis of an incorrect assumption as regards CMP303 Original and the Potential Alternatives (of which we focus here on 2(b) and 4(b) as these have merit).</p> <p>It appears, from Appendix 3, that the ESO is assuming that it is better, in terms of cost reflectivity, to recover the costs associated with these changes etc., for Demand; such as with bi-directionality and the distribution saving offset; from Generation TNUoS and not Demand via, for example, DUoS.</p> <p>We do not agree with this central premise of the ESO's analysis.</p> <p>The additional costs of (i) bi-directionality (in CMP303 Original) and then (ii) the re-allocation of the TO costs that are offset by the avoided costs of not building a Distribution link because of the building of a Transmission link (in Potential Alternatives 2(b) and 4(b) – with the Alternative 1 aspects recovered from TNUoS) should be recovered, cost reflectively, from those users who benefit from those aspects, namely Demand via, for example, DUoS rather than TNUoS.</p>

CUSC Workgroup Consultation Response Proforma

CMP303 “Improving local circuit charge cost-reflectivity”

Industry parties are invited to respond to this consultation expressing their views and supplying the rationale for those views, particularly in respect of any specific questions detailed below.

Please send your responses by **22 January 2019** to cusc.team@nationalgrid.com. Please note that any responses received after the deadline or sent to a different email address may not receive due consideration by the Workgroup

These responses will be considered by the Workgroup at their next meeting at which members will also consider any Workgroup Consultation Alternative Requests. Where appropriate, the Workgroup will record your response and its consideration of it within the final Workgroup report which is submitted to the CUSC Modifications Panel.

Respondent:	Simon Swiatek sswiatek@forsaenergy.com
Company Name:	Forsa Energy
Do you believe that the proposed original better facilitate the Applicable CUSC Objectives? Please include your reasoning.	(a) Yes - the removal of additional costs that are unrelated to the generator’s needs will assist generators in market competition. (b) Yes – the proposal means the local circuit charge payable by the generator will be reflective of the costs incurred by the relevant transmission licensee in providing the required export capability (removing any extra costs unrelated to the required export capability). (c) Yes - this proposal will take account of developments in transmission licensees’ business such as providing HVDC links to remote island. The proposal will mean that costs unrelated to export capability are not assigned to generator local circuit tariffs.
Do you support the proposed implementation approach? If not, please state why and provide an alternative suggestion where possible.	Yes. We agree with section 7 of the consultation that the modification would require an authority decision at least a few weeks in advance of the proposed CFD auction. This is required in order to allow generators to review their financial modelling and finalise their auction bids.
Do you have any other comments?	No
Do you wish to raise a Workgroup Consultation Alternative request for the Workgroup to consider?	No

Specific questions for CMP303

Q	Question	Response
5	<p>Do you consider that any of the potential alternatives set out in Section 4 do not have merit? Please provide your rationale.</p>	No
6	<p>Do you consider that any or potential alternatives set out in Section 4 do not have merit? if so please provide your rationale</p>	(same question as above?)
7	<p>National Grid ESO have identified a number of potential implications associated with CMP303 which are set out in Appendix 3. Do you agree or disagree with this assessment? If so, please explain why</p>	<p>The assessment clearly shows the impact on generation residual for various different reductions in local circuit revenue.</p>

cusc.team@nationalgrid.com

22 January 2019

Dear Sir/Madam

CMP303 consultation

We welcome this opportunity to respond to the work group consultation on CMP 303 – Improving local circuit cost charging reflectivity.

HIE along with its local partners - the democratically elected local authorities covering the north of Scotland and the islands; Shetland Islands Council, Orkney Islands Council, Comhairle nan Eilean Siar, The Highland Council and Argyll & Bute Council - make representations to key participants to influence the way in which regulation of the energy industry is managed in order to ensure the needs and interests of the Highlands and Islands are understood and taken into consideration. HIE also works closely with Scottish Government in relation to grid regulatory matters.

The Highlands and the Islands off the north and west coast represent a large geographical region. The region has a low population density with many pockets of population spread across areas that are often remote. The region is home to a large volume of renewable energy power stations – from small scale, local developments to very large commercial installations. There are many more sites across the region that could be exploited to provide yet more cost effective, low carbon, renewable energy. Establishment of new transmission connections from Western Isles, Shetland and Orkney is critically important to the ability of these areas to exploit their substantial renewable energy resources and secure the considerable economic benefits associated with doing so. We therefore have a keen interest in this proposal, and any others which may support investment in these connections.

This consultation is very timely as needs case submissions for the Scottish Islands are presently being made to Ofgem, and the next CfD auction within which remote island wind will be eligible to compete is imminent. We note that discussions reflective of CMP303 were held during Project TransmiT and CMP213 but not progressed as these work streams had other key aims.

Noting the above, we believe this consultation is now extremely important in crystallising the previous discussions in today's context. Put in simple terms, we do not believe the existing generator local circuit charging methodology as relates to HVAC subsea cables and HVDC reflects the wider transmission system benefits that are accrued by such works and are not required by the generators currently being asked to pay for them. We believe CMP303 correctly identifies this defect and is correct in

examining solutions to it.

Consultation questions and our responses

Q1: Do you believe that CMP303 Original proposal better facilitates the Applicable CUSC Objectives?

Section 6 of the consultation sets out five applicable CUSC objectives and suggests that the CMP303 proposal has a positive impact on three of them, primarily related to cost reflectivity and promotion of competition. Two of the five are identified as not applicable. We agree with this assessment.

We believe that CMP303 improves the baseline CUSC in relation to promoting competition and increasing cost reflectivity whilst having no adverse impacts of significance. In relation to the current treatment of generator local circuit charges for HVAC subsea cables and HVDC we believe it is almost unarguable that these transmission works provide benefits beyond those required by the generators using them. We therefore agree with CMP303 that costs associated with these additional benefits should be removed and consider that the key issue is in quantifying them. We further note that this latter point is reflective of the discussions during Project TransmiT and CMP213 and of Ofgem's final position at that time in that insufficient quantification was provided at that time as evidence.

Q2: Do you support the proposed implementation approach?

We broadly support the implementation approach and timetable proposed agreeing with the urgent need to establish an outcome ahead of the CfD auctions. Whilst we completely agree with the CMP303 proposal and believe it is correct in identifying the CUSC defect and in proposing to remove costs that are not relevant to the generators, we are concerned at this stage that there appears to be some uncertainty over what the costs relate to and how the costs are calculated. We note that there is a variety of alternatives and many of these are case specific and require a good deal of technical and cost assessment work. Given the potential difficulty in establishing a clear method and answer in the required timescales, we hope that this will be afforded the priority required.

Q3: Do you have any other comments?

We note the short timelines associated with this work group and have some concerns that there may be other benefits of HVAC subsea or HVDC links that have not yet been considered. Given the issues around timelines we are comfortable that the working group should progress as is but would seek assurance that further modifications in relation to other benefits could be raised at a later date.

We note and welcome the working group's comments and confirmations that CMP303 is applicable on a GB basis even though the current extent of relevant HVAC subsea cables and HVDC is somewhat limited. In this context we note it is important that the original proposal and alternatives are also considered in the wider GB context.

Q4: Do you wish to raise a Workgroup Consultation Alternative request for the Workgroup to consider?

We do not wish to raise an alternative.

Q5: Do you consider that any or potential alternatives set out in Section 4 have merit? if so please provide your rationale.

We believe that the original proposal and all the alternatives 1 and 2 are relevant and have merit. We note that they fall into two broad categories related to demand (or import) provision, and the wider benefits of HVDC. Therefore, we believe that a combination of the original and alternatives 2 must be taken together with alternatives 1, e.g. alternative 2c and 1 could be taken or, alternative 2a and 1a etc. The task of the workgroup is to assess which combination is best.

It has been clear (at least since Project TransmiT and CMP213) that HVDC provides a wider system benefit and hence either alternative 1 or 1a should be selected. We suggest that 1a be considered first in that it examines the actual costs on a case specific basis and hence is most cost reflective. However, if the answers are consistent and support alternative 1, then alternative 1 should be adopted in the interests of simplicity. We further note that this approach would meet the Section 6 CUSC (e) objective of promoting efficiency in implementing the CUSC. We would welcome a National Grid ESO or transmission owner analysis of alternative 1a to provide a separate and validating view of the functionality and costs that are presented in Annex 3. We also note the alternative 1a proposer's comments that other HVDC functionality and costs could be included.

It has also long been clear that such HVAC subsea and HVDC links not only provide for generation export but also provide for import and demand security. Therefore, the original and one of the alternatives 2 are relevant and one should be selected. As with our comments above in relation to HVDC, we welcome a case specific approach but consider an approach that simplifies matters desirable. In this respect alternative 2b and 2c would appear to have most merit.

Q6: Do you consider that any or potential alternatives set out in Section 4 do not have merit? if so please provide your rationale.

As noted above, we consider that all alternatives have some merit, however, 2 (a) and, as a knock-on 4(a), could be construed as less cost reflective than 2 (b) and 4 (b) as they seek to apply a generic percentage to TNUoS subtraction, rather than applying actual costs on a case by case basis. On that basis, we do not agree that these should be considered further.

Q7: National Grid ESO have identified a number of potential implications associated with CMP303 which are set out in Appendix 3. Do you agree or disagree with this assessment? If so, please explain why.

We welcome the National Grid ESO analysis in Annex 3 and pages 9 and 10 of the consultation and note that it concludes the impact on consumers as negligible and the impact on other generators as very small – a small increase in the generator residual charge. From this it can be concluded that no adverse impacts are to be expected from improving the generator local circuit charging by modifying the current charging arrangements through CMP 303. We absolutely agree with this assessment.

We do however note Ofgem's Targeted Charging Review may affect this and National Grid ESO's comments that removal of the generator residual would mean a small increase in the demand residual as a result of CMP303. We do not necessarily see this as an issue as it would be demand that would in fact be the main beneficiary of the additional benefits of the HVAC subsea cables and HVDC, e.g. via provision of demand security, black start provision, transmission system control functions.

We hope you find these comments helpful, and we look forward to seeing the results of the consultation in due course.

Yours faithfully

A rectangular box containing a handwritten signature in cursive script that reads "Elaine Hanton".

Elaine Hanton
Head of Energy: Emerging Technologies and Regulation

In partnership with:-
Shetland Islands Council
Orkney Islands Council
Comhairle nan Eilean Siar
The Highland Council
Argyll & Bute Council

CUSC Workgroup Consultation Response Proforma

CMP303 “Improving local circuit charge cost-reflectivity”

Industry parties are invited to respond to this consultation expressing their views and supplying the rationale for those views, particularly in respect of any specific questions detailed below.

Please send your responses by **22 January 2019** to cusc.team@nationalgrid.com. Please note that any responses received after the deadline or sent to a different email address may not receive due consideration by the Workgroup

These responses will be considered by the Workgroup at their next meeting at which members will also consider any Workgroup Consultation Alternative Requests. Where appropriate, the Workgroup will record your response and its consideration of it within the final Workgroup report which is submitted to the CUSC Modifications Panel.

Respondent:	<i>Aaron Priest, Head of Development and Strategy, Viking Energy Shetland, North Ness Business Park, Lerwick, Shetland ZE1 0LZ on behalf of Viking Energy Windfarm LLP. aaron.priest@vikingenergy.co.uk</i>
Company Name:	<i>Viking Energy Wind Farm LLP</i>
Do you believe that the proposed original better facilitate the Applicable CUSC Objectives? Please include your reasoning.	<p><i>(a) That compliance with the use of system charging methodology facilitates effective competition in the generation and supply of electricity and (so far as is consistent therewith) facilitates competition in the sale, distribution and purchase of electricity; Viking Energy Wind Farm LLP (VEWF) believes that the proposed original will have a positive impact on this objective. Currently TNUoS charges for HVDC circuits include costs which are not properly cost reflective which results in distortion of competition by disadvantaging those generators who have to pay costs which are excluded on equivalent HVAC circuits.</i></p> <p><i>(b) That compliance with the use of system charging methodology results in charges which reflect, as far as is reasonably practicable, the costs (excluding any payments between transmission licensees which are made under and accordance with the STC) incurred by transmission licensees in their transmission businesses and which are compatible with standard licence condition C26 requirements of a connect and manage connection);VEWF believes that the proposed original will better facilitate this objective. Current HVDC TNUOS charging arrangements include charges which are not properly cost reflective and which are discriminatory when compared to treatment of equivalent export via HVAC circuits.</i></p> <p><i>(c) That, so far as is consistent with sub-paragraphs (a) and (b), the use of system charging methodology, as far as is reasonably</i></p>

	<p><i>practicable, properly takes account of the developments in transmission licensees' transmission businesses; VEWf believes that the proposed original will help to ensure that the CUSC and use of charging methodology treats HVDC links in a fair, more cost-reflective and non-discriminatory manner, as required within TOs' transmission licences.</i></p> <p><i>(d) Compliance with the Electricity Regulation and any relevant legally binding decision of the European Commission and/or the Agency. These are defined within the National Grid Electricity Transmission plc Licence under Standard Condition C10, paragraph 1*; VEWf believes that the original is neutral in terms of this objective. and</i></p> <p><i>(e) Promoting efficiency in the implementation and administration of the CUSC arrangements.</i></p> <p><i>*Objective (d) refers specifically to European Regulation 2009/714/EC. Reference to the Agency is to the Agency for the Cooperation of Energy Regulators (ACER). VEWf believes that the original is neutral in terms of this objective.</i></p>
<p>Do you support the proposed implementation approach? If not, please state why and provide an alternative suggestion where possible.</p>	<p><i>VEWf agrees that the implementation process and date should be compatible with the requirements of the announced May 2019 CfD auction. VEWf agrees that, if the CfD auction is to run fairly and competitively, all bidding plant must be able to properly understand and forecast the local circuit element of their TNUoS charge. Therefore a decision is required by the Authority in time for parties to take that decision into account when they participate in that auction.</i></p>
<p>Do you have any other comments?</p>	<p><i>VEWf wishes to reiterate its belief that there is strong evidence to suggest discriminatory TNUoS charging arrangements for HVDC circuits under the CUSC, as it stands, when compared to the treatment of HVAC circuits. VEWf wishes to reiterate that these arrangements are not properly cost reflective. Discrimination, and arrangements which are not properly cost reflective, would constitute a breach of GBSO licence conditions and need to be addressed and rectified quickly. It is arguable that the forthcoming May 2019 CfD auction's fairness and competitiveness could be called into question unless these anomalies are rectified quickly.</i></p> <p><i>The following text is lifted from the EU Renewable Energy Directive (2009/28/EC), which, according to the European Union (Withdrawal) Act 2018 will continue to apply post-Brexit.</i></p> <p><i>“3. Member States shall require transmission system operators and distribution system operators to set up and make public their standard rules relating to the bearing and sharing of costs of technical adaptations, such as grid connections and grid</i></p>

	<p><i>reinforcements, improved operation of the grid and rules on the non-discriminatory implementation of the grid codes, which are necessary in order to integrate new producers feeding electricity produced from renewable energy sources into the interconnected grid.</i></p> <p><i>Those rules shall be based on objective, transparent and non-discriminatory criteria taking particular account of all the costs and benefits associated with the connection of those producers to the grid and of the particular circumstances of producers located in peripheral regions and in regions of low population density. Those rules may provide for different types of connection.”</i></p> <p><i>“7. Member States shall ensure that the charging of transmission and distribution tariffs does not discriminate against electricity from renewable energy sources, including in particular electricity from renewable energy sources produced in peripheral regions, such as island regions, and in regions of low population density.”</i></p>
<p>Do you wish to raise a Workgroup Consultation Alternative request for the Workgroup to consider?</p>	<p><i>No, VEWf instead wishes to offer support for one of the alternatives set out in Section 4.</i></p>

Specific questions for CMP303

Q	Question	Response
---	----------	----------

Q	Question	Response
5	<p>Do you consider that any of the potential alternatives set out in Section 4 do/ do not have merit? Please provide your rationale.</p>	<p><i>VEWF believes that proposed alternatives 1 and 1 (a) have merit. Removing converter costs and the costs of wider system functionality not required for generator export will level the playing field in the treatment of, and charging arrangements for, HVDC circuits. By definition, this will help to tackle existing discrimination and will improve cost reflectivity.</i></p> <p><i>VEWF considers that potential alternative 2 (a) does not have merit as it is not cost reflective. VEWf supports the underlying principle in alternative 2 which is – “For Island HVDC Transmission Charges, recognise the alternatives of making a supply to the islands and subtract this benefit from the cost before applying TNUoS.” as this is more cost reflective. However, the wording in 2 (a) which VEWf believes does not have merit (as it’s not cost reflective) is the following sentence: “As these costs are clear for Shetland, use the Shetland percentage as the model and apply same percentages to HVDC link to the Western Isles and Orkney”. VEWf is of the view that project specific figures, on an island by island basis, would be more cost reflective than the arbitrary application of a generic percentage based solely on one (Shetland) island network. For these reasons, VEWf supports the wording of potential alternative 2 (b). Also, as potential alternative 4 (a) is a hybrid containing the wording of 2 (a), VEWf considers it not to have merit (as it’s not cost reflective) and favours the wording within 4 (b), which is VEWf’s preferred overall option from the potential alternatives set out in the Workgroup consultation.</i></p> <p><i>For the record, VEWf believes that any costs related to changes to Grid Supply Points and related security factor definitions, associated with making supply to the islands via HVDC links, should sit with the relevant DSO. This is based on the principle of maintaining appropriate cost reflectivity.</i></p>
6	<p>Do you consider that any or potential alternatives set out in Section 4 do not have merit? if so please provide your rationale</p>	<p><i>See answer to 5 above.</i></p>

Q	Question	Response
7	National Grid ESO have identified a number of potential implications associated with CMP303 which are set out in Appendix 3. Do you agree or disagree with this assessment? If so, please explain why	<i>Further detailed impact analysis will be required as the range of options narrows. Current analysis is recognised by all parties as “initial and very high level”.</i>

CUSC Workgroup Consultation Response Proforma

CMP303 “Improving local circuit charge cost-reflectivity”

Industry parties are invited to respond to this consultation expressing their views and supplying the rationale for those views, particularly in respect of any specific questions detailed below.

Please send your responses by **22 January 2019** to cusc.team@nationalgrid.com. Please note that any responses received after the deadline or sent to a different email address may not receive due consideration by the Workgroup.

These responses will be considered by the Workgroup at their next meeting at which members will also consider any Workgroup Consultation Alternative Requests. Where appropriate, the Workgroup will record your response and its consideration of it within the final Workgroup report which is submitted to the CUSC Modifications Panel.

Respondent:	Paul Mott
Company Name:	EDF Energy
Do you believe that the proposed original better facilitate the Applicable CUSC Objectives? Please include your reasoning.	<p>Yes. Regarding (a) (<i>facilitates effective competition in the generation and supply of electricity</i>) – the original allows relevant generators to compete fairly in the market without being handicapped by paying extra costs unrelated to the export of their power.</p> <p>Regarding (b) (<i>.....charges which reflect, as far as is reasonably practicable, costs</i>), the original ensures relevant generators face a cost-reflective local circuit charge, without paying for extra costs unrelated to the export of their power.</p> <p>Regarding (c) (<i>...properly takes account of the developments in transmission licensees’ transmission businesses</i>), the original better meets this, as HVDC island links don’t exist yet, and the original, among other scenarios, covers the case where the TO adds bidirectionality as a function to such a link – so that such a development would be properly taken account of in a fair and cost-reflective manner</p> <p>(d) Compliance with the Electricity Regulation and (e) Promoting efficiency in the implementation and administration of the CUSC arrangements, do not seem relevant.</p> <p>Thus, overall the objectives are better met.</p>
Do you support the proposed implementation approach? If not, please state why and provide an alternative suggestion where possible.	<p>We agree that CMP303 original proposal, and its WACMs, are all linked to an imminent date related issue; namely the date of the next CFD auctions that some local-circuit-connected generators, both AC and DC connected, will compete in to secure support, which is expected to be held by c. May 2019 (in any event, by or before June 2019). In order to compete in this auction efficiently, this generation plant must be able to forecast the local circuit</p>

	tariff element of their TNUoS charge (which could be materially impacted if this proposal was or was not approved). Therefore timing must allow for a decision by the Authority (with it to be implemented at the start of next charging year) at least a few weeks ahead of the auction. The timeframe is just adequate.
Do you have any other comments?	-
Do you wish to raise a Workgroup Consultation Alternative request for the Workgroup to consider?	-

Specific questions for CMP303

Q	Question	Response
----------	-----------------	-----------------

Q	Question	Response
5	<p>Do you consider that any of the potential alternatives set out in Section 4 have merit? Please provide your rationale.</p>	<p>The potential alternatives have potential merit, because they try to help estimate the wider benefits that such local circuit links can bring in varying ways. In doing so, they have the potential to improve the cost-reflectivity of the charge for such links.</p> <p>Potential Alternative 1a proposed by Xero, "Wider System Benefits of HVDC", would require the identification by the TO of the costs of equivalent plant or services (e.g. quad boosters and AC compensation) that would have been used for an AC connection. The costs of the equivalent plant or services are then deducted from the HVDC costs entered into the generator local circuit TNUoS charge calculation to reduce the local circuit charge the relevant generators pay, as opposed to WACM1's comparable but simpler deduction of converter costs (below). Under the CMP303 original approach, the TO might not feel invited or entitled to consider these costs which are directly associated with the choice of link technology, yet which arise away from the actual link; WACM1a would make clear to exclude these costs.</p> <p>Potential WACM 1 would require the TO to remove all converter station costs from HVDC charging. This is argued by its proposer to have merit because the HVDC approach would provide additional functionality over an AC link, which is inherent with the installation of HVDC equipment/cable. Power electronics (converter) type costs would also exist within the AC world as well as DC in the form of costs for technology such as quad boosters (to direct AC power flows elsewhere on adjacent bits of network), yet which aren't needed adjacent to a DC link, as a DC link's flows can be very directly and precisely controlled. The costs of quad boosters are excluded from AC local circuit charges, and given similar functionality should, WACM1 suggests, the costs of the converter stations should be excluded from DC local circuit costs for charging purposes. Potential WACM1 simplifies calculations compared to potential WACM 1a, by not undertaking the case by case analysis.</p> <p>Potential WACM 2a arises from agreement at the workgroup that having bi-directionality of a future transmission link would further reinforce islands and could only add to their security of supply level. It suggests that the alternative of making a supply to the islands via distribution rated HVDC is identified, this amount being subtracted from the local circuit cost before calculating the local circuit charge. As the proposer argues that these costs have been painstakingly identified for the Shetlands, via a competition to replace the power station there, that identified the lowest cost solution as an HVDC transmission link from Shetland to GB mainland. As the equivalent cost might be hard to identify for other islands, the potential WACM proposes to use Shetland as the model and to apply the same %ages to HVDC link to other HVDC connected islands.</p> <p>Potential WACM 2b is as above but island-specific – this has less merit, as this data would be very hard to assess for the western isles</p> <p>Potential WACM 2c also has potential merit; it considers the value of the new links in supplying demand ... for subsea cable connections that constitute a generator local circuit for the purposes of TNUoS charging, it suggests that the proportion of the connection that relates to maximum import, compared to maximum export, is calculated and that this proportion of total link cost should not be charged to the relevant generators, using a cost pro-rating approach. The remaining two potential options are merely hybrids of the above potential alternatives.</p>

Q	Question	Response
6	<p>Do you consider that any or potential alternatives set out in Section 4 do not have merit? if so please provide your rationale</p>	<p>Potential WACM 2b is as WACM2a but island-specific – this has <u>less</u> merit, as this data would be very hard to assess for the western isles. It is unclear if it is practical and proportionate.</p>
7	<p>National Grid ESO have identified a number of potential implications associated with CMP303 which are set out in Annex 3. Do you agree or disagree with this assessment? If so, please explain why</p>	<p>ESO have modelled reductions in the local circuit revenues (of certain parties) by 10%, 30% and 60% compared to baseline (no change). There is only an impact on the generation residual tariff. The demand residual tariff is not impacted at all. The generation residual increases by between 10p and 57p from the three synthesised scenarios, becoming less negative. Therefore, the modelling shows that this modification, in reducing the local circuit tariffs for any relevant generators, will increase the generation residual, but with no modelled effect at all on the demand residual (TDR) and hence on demand side TNUoS. We expected this outcome, and are in accord.</p>

CMP303 Initial Impact Analysis of the Modification

CMP303 'Improving local circuit charge cost-reflectivity', was raised by EDF in September 2018. This modification looks to make part of the TNUoS charge more cost reflective through the removal of additional costs from the local circuit expansion factors that are incurred beyond the connected, or to-be connected, generation developers need.

Following the first workgroup, NGENSO has conducted some very high level analysis on the impacts of this, using a very simplistic method of applying percentage decreases to local circuit revenue. There are some caveats which need to be considered when looking at the results of this analysis:

- The local circuit revenue amounts have been amended rather than the local circuit expansion factors. This is because these factors are contained within the Transport & Tariff model. Therefore, taking into account the time it would need and the complexities around this method of analysis we decided to adjust the local circuit revenue amounts as this would be sufficient for an initial impact analysis.
- We have used a percentage change in the local circuit revenue amounts rather than a specific figure as no methodology has been worked out yet. Therefore, this is a good way to see potential impacts on tariffs initially before a clear solution is developed by the workgroup.

To carry out the analysis, we have conducted a number of scenarios. We have reduced the local circuit revenues (of certain parties) by 10%, 30% and 60% compared to baseline (no change).

The following graph shows the change in local circuit revenue for each scenario:

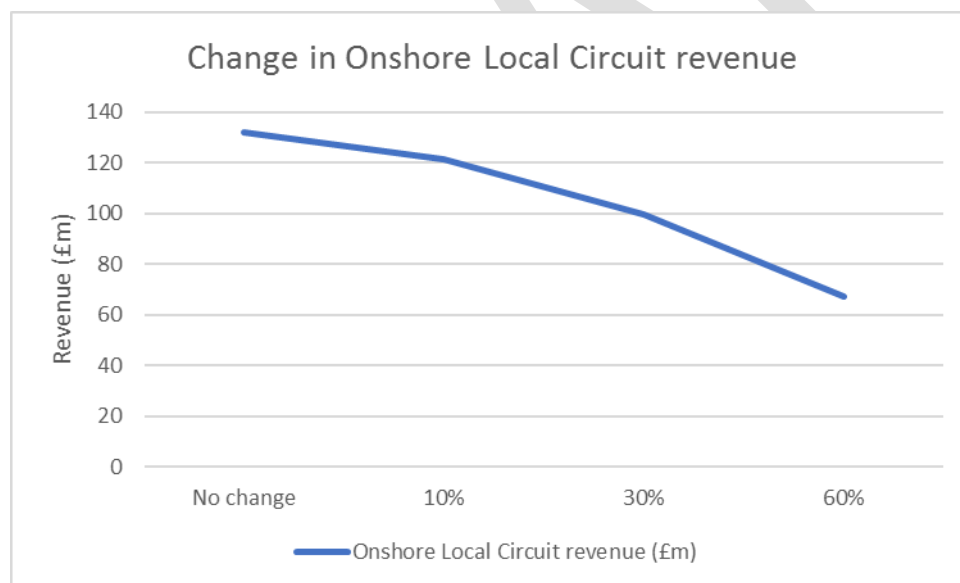

(Source: Analysis based on August 2018 5-year forecast, using 2023/24 scenario T&T model)

The following table notes the impacts on residual tariffs (both demand and generation):

	Generation Residual	Monetary change in Gen Residual compared to baseline	Demand Residual	Monetary change in Dem Residual compared to baseline
No change (baseline)	-8.31	0.00	66.79	0.00
10% decrease	-8.21	-0.10 (i.e. less negative)	66.79	0.00
30% decrease	-8.02	-0.29	66.79	0.00
60% decrease	-7.74	-0.57	66.79	0.00

(Source: Analysis based on August 2018 5-year forecast, using 2023/24 scenario T&T model)

As you can see from the table there is only an impact on the generation residual tariff. The demand residual tariff is not impacted at all. The generation residual increases by between 10p and 57p from the scenarios we have used, becoming less negative.

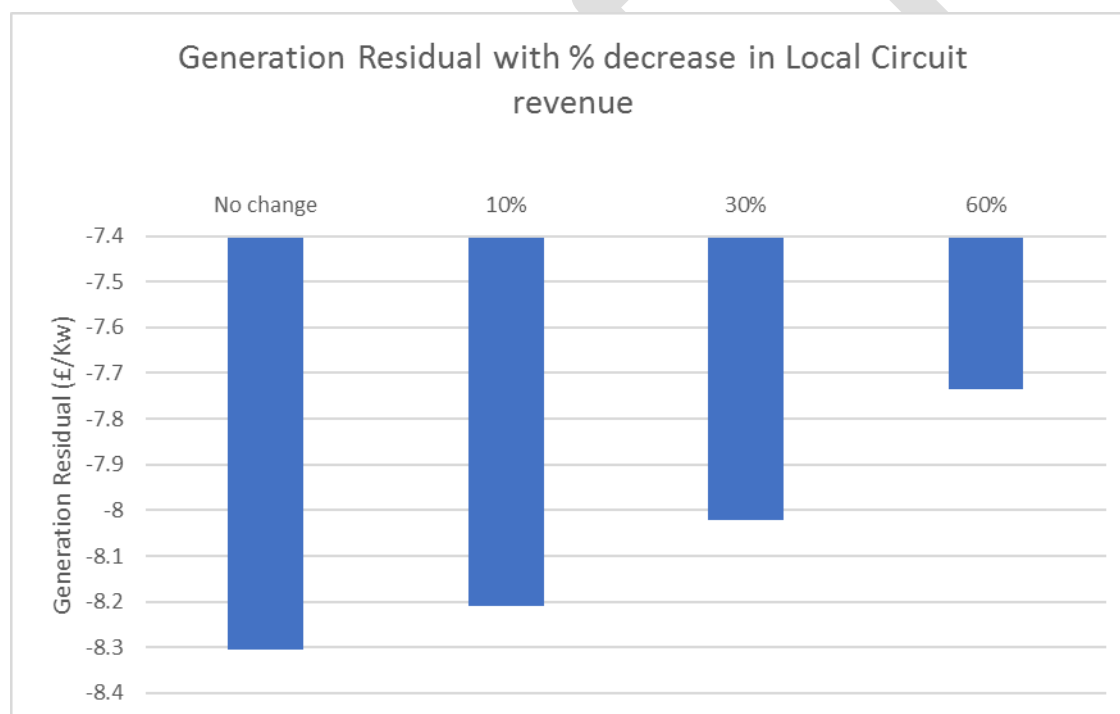

(Source: Analysis based on August 2018 5-year forecast, using 2023/24 scenario T&T model)

Therefore, this modification will reduce the local circuit tariffs for generators who will be covered by this modification. However, this reduction has (from the analysis above) reallocated the costs to the generation residual and so all other generators will pick up the costs of this modification in this scenario.

As this is only initial and very high level analysis, the workgroup will need to consider their solution in detail. Due to the intricacies of the Transport and Tariff Model, the modification will have to be very clear on what calculation will need to take place and also the information provision from the TO and how this fits into the model. This will ensure that the analysis is reflective of the modification's intent.

18 Annex 5: Workgroup Member Analysis

CMP303 GB HVDC ISLAND TRANSMISSION CHARGING

Submission to Working Group for Connection and Use of System Code (CUSC) modification CMP303 regarding transmission charging for HVDC and remote islands in GB.

The contents of this presentation are the work of the author and are for consideration, discussion, endorsement, modification, enhancement or correction by the working group and are not necessarily approved or endorsed by Statkraft.

Distribution: CMP303 Workgroup

Prepared by Guy Nicholson 29/10/2018



Contents

- ▶ Defect defined in CMP303
- ▶ Evidence of defect and additional costs of AC solutions
- ▶ Charging of AC onshore vs HVDC to islands
- ▶ More AC substations provide more AC transmission capacity
- ▶ AC circuits require more assets than just cables or lines in order to function
- ▶ HVDC can be cheaper than AC
- ▶ Optimisation of capacity for lower costs and charges
- ▶ WACMs

Defect stated in CMP303

1 Summary

Defect

When a new local circuit is built to enable the export of new generation, extra costs may be incurred on additional functionality that is unrelated to the needs of said generation.

The defect is that, absent clarification of the exclusion of these extra costs, they are very likely to be included in the actual costs used to calculate the expansion factor and hence the relevant local circuit charge, meaning that relevant generators are facing a local circuit charge that is not fully cost-reflective.

Evidence of defect and additional costs of AC solutions (1of2)

- ▶ As evidence of the defect, an analysis has been undertaken of the reinforcement works proposed for the new Hinkley Point power station.
- ▶ The capacity increase delivered and the lengths of overhead line and cable have been multiplied by the expansion factors to determine the proportion of project Capex associated with these elements that is used in the TNUOS charges.
- ▶ The costs for Hinkley – Seabank are £800m (Ofgem).
- ▶ The new connection is 48.5km of overhead line and 8.5km of underground cable (NG Hinkley Connection Project).
- ▶ The incremental TEC delivered is the new TEC ($2 \times 1670 - 1261$) = 2079MW (TEC Register).

Executive Summary

The Hinkley-Seabank Project

The Hinkley-Seabank project (HSB) is an electricity transmission project to connect EDF's Hinkley Point C nuclear power station to the GB transmission network. HSB has been progressed through the planning process by National Grid (NGET) as the transmission owner (TO) for England and Wales. The cost of the project is currently estimated at close to £800m.

<https://hinkleyconnection.co.uk/project-summary/>

The Hinkley Connection project is a new high-voltage electricity connection between Bridgwater and Seabank near Avonmouth. It is a significant investment in the region's electricity network and will enable us to connect new sources of power to homes and businesses, including Hinkley Point C, EDF Energy's new nuclear power station in Somerset.

It will play a vital role in delivering electricity efficiently, reliably, and safely and will support the UK's move to reduce carbon emissions.

The new connection will be 57 km long - consisting of 48.5 km of overhead line and 8.5 km of underground cable through the Mendip Hills Area of Outstanding Natural Beauty (AONB).

We are also making significant changes to the local electricity network owned by Western Power Distribution (WPD) by removing 67km of overhead line. See [here](#) for further information.

Hinkley Point 400kV Substation	1,261.00	-200.00	1,061.00	01-04-2017
Hinkley 400kV Substation	0.00	1,670.00	1,670.00	06-12-2024
Hinkley 400kV Substation	0.00	1,670.00	1,670.00	06-12-2025

Evidence of defect and additional costs of AC solutions (2of2)

- The Expansion factor for OHL is 14.083 £/MWkm
- The multiplier for 400kV cable is 10.2
- The Annuity factor is 5.8% (statement of use of system charges)

So the Capex for OHL is 242.81£/MWkm
for Cable is 2,476.67 £/MWkm

Applying the km of line/ cable and the MW for the increased capacity yields the capex for the OHL and the cable:

OHL Capex	26.84£m
Cable Capex	47.98£m
OHL+ Cable Capex	74.81£m

The calculated capex on OHL and Cable is only 9% of the total project capex of £800m, presumably as it does not cover costs of substations, undergrounding and diverting DNO assets, etc etc.

I.e. for Hinkley ~90% of the reinforcement costs are socialised.

This situation should be compared to the approach to HVDC on the Islands where [100%] of the costs are included in the expansion factor and therefore in charges to generation users.

In addition Hinkley Point has -ve generation charges, so it is not contributing to the £800m reinforcement capex, that contribution must come from other users/generators.

Issue	Revision
14	0

This is a copy of the statement provided to Ofgem on 7 March for approval of form under licence condition C4.8.

The Statement of Use of System Charges

Effective from 1 April 2018

Table 1.1: TNUoS Calculation Parameters

Parameter	Value/Basis
Transport model network, nodal generation & nodal demand data	Based upon various data sources as defined in Section 14 of the Connection and Use of System Code (CUSC)
Expansion constant	£14.08310010/MWkm
Annuity factor	5.8%
Overhead factor	1.8%
Locational onshore security factor	1.8
Offshore civil engineering discount	£0.440694 /kW

Charging of AC onshore vs HVDC to islands

- ▶ Onshore AC connections require substations but substation costs are socialised. Imagine the first 275kV circuit built in UK from Tyneside to Strathclyde. This line would require 275kV substations which did not exist before. This is analogous to HVDC requiring converter stations. The onshore AC assets constructed for Hinkley require undergrounding of DNO assets to achieve planning. These costs are socialised and not assigned to the generator concerned, however the cost of undergrounding/subsea installation to the islands required by the physical geography is currently allocated to the island users.
- ▶ There is undue discrimination against island users.

More AC substations provide more AC transmission capacity

- ▶ Adding substations to the AC network increases transmission capacity even though the costs of these substations are socialised and not added to the expansion constant.
- ▶ Take the Pembroke to Walham 400kV circuit as an example. It is the longest 400kV circuit in GB (ETYS2017), however it is proposed to shorten this circuit by turning it into Swansea North substation. This turn-in cost is associated with the substation and is not charged to the expansion factor. The AC work to improve capacity is socialised, whereas HVDC, which provides such long distance transmission capacity in the first place, has the costs of the converter stations (which are equivalents to substations) charged to the expansion factor.

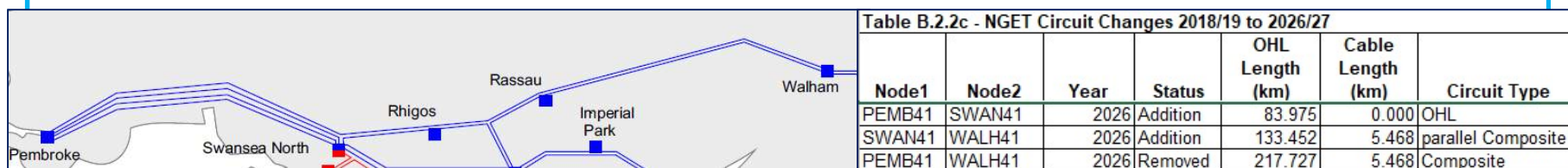

- ▶ Compare this situation to a hypothetical HVDC link where a third converter station is added halfway along the link to improve the transmission capacities of the overall system. This third converter station would result in an increased expansion factor for the circuit, with an increase in TNUOS to users at the far end, although there is no benefit to those far end users of the third converter station.

AC circuits require more assets than just cables or lines in order to function

- ▶ AC networks generate and consume reactive power according to their power flow/loading. Series capacitors are deployed to reduce their impedance. Quad boosters are applied to manage the sharing of flows. None of these assets or the substations they sit in are charged in the expansion factor. Also AC networks incur ancillary services costs to manage these issues and deliver the thermal capability of AC lines. These services and costs are not required or incurred for HVDC island links yet the converter stations, which enable these cost savings, are charged in TNUOS, via the expansion factor, which is undue discrimination for HVDC vs AC assets.
- ▶ For example, an IEEE Paper by Colin Bayfield of Scottish Power showed that half the costs associated with the Harker to Strathavan 400kV line build in the mid 1990s were associated with the costs of the overhead line, the other half were for substations and stability. Since it was built, a number of other substations have been added along the 400kV line and Series capacitors applied to increase the boundary capacity of the same asset with the same thermal rating.
- ▶ HVDC does not require any of these add-ons, so is discriminated against in the charging regime.

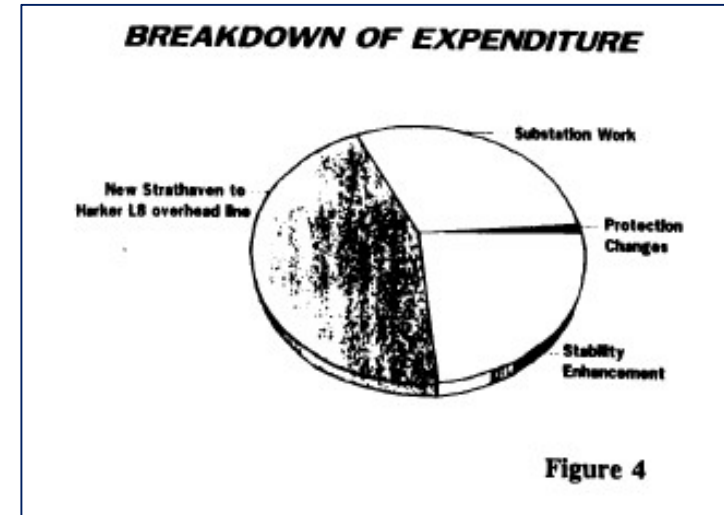

- ▶ IEEE paper on cost of new 400kV overhead line - with 50% being non overhead line costs

Optimisation of capacity for lower costs and charges

- ▶ OFTO assets are designed and built by offshore developers. The developers control the ratings and costs of these assets and can manage their TNUOS charges as a result.
- ▶ Island developers do not control the size or cost of assets, which is determined by the TO, therefore island developers are not able to manage TNUoS charges.
- ▶ For example, based on the HVDC cost model developed for Greenlink and Maali interconnector projects, Statkraft have calculated that the additional costs of taking the Shetland HVDC connection from 600 to 800MW is less than 4% for the 33% capacity increase. The larger capacity would reduce TNUOS by a greater amount than the increase in capital cost. The offshore developer can manage and exploit such benefits of scale, whereas the island developer cannot.

HVDC solutions are can have lower capex than AC

- ▶ There is an assumption in some quarters that HVDC solutions are always more expensive than AC solutions, however this is not always the case. The competition to replace the Shetland Power Station demonstrated that an HVDC link (with converters and cables) was the most cost effective. We assume that National Grid Ventures, who proposed the HVDC solution, did so because it was more cost effective than using AC.



Consultation on the cost of the new energy solution for Shetland

1.10. SSEN has now completed the competitive process and has informed Ofgem that its preferred bidder is a joint bid by NGSLL and Aggreko, the preferred Shetland New Energy Solution (SNES). The solution involves building a High Voltage Direct Current (HVDC) link between Shetland and mainland GB with a back-up diesel generator on Shetland.

HVDC island links provide security of supply

- ▶ The Shetlands are not connected to the GB grid and the power station requires replacement. A competition to replace the station identified the lowest cost solution as an HVDC link from Shetland to mainland. The cost of the HVDC part of the solution was [£279m] if a transmission link is built to Shetland to enable generation exports, the link will also provide an island supply to replace the power station with a capital saving of [£279m]. This avoided cost should be deducted from the actual cost of the HVDC transmission link before TNUOS charges are calculated.
- ▶ The same principle of security of supply applies to other remote islands, and as cost saving information is not to hand for these islands the same %age cost reduction for charging should be applied to other remote islands with HVDC links as for Shetland.

Arbitrary Geographical and historical nature of TNUOS

- ▶ It has been shown that for the Hinkley point reinforcements, 90% of the costs are associated with works other than the 400kV overhead lines and cables themselves.
- ▶ When the Beaulieu Denny 400kV upgrade was completed there was a reduction in the northerly TNUOS charges because of the decreased unit capacity costs.
- ▶ Both of the above works incurred investment costs but did/will not raise charges commensurately.
- ▶ In parts of GB, old and new assets have been built at lower voltages than 400kV for permitting or historic reasons. These lower voltages incur higher local TNUOS charges on generation users, however there is no commensurate reduction in charges for demand users.
- ▶ Transmission reinforcements are increasingly expected to involve sections of more expensive underground cable in order to satisfy contemporary visual sensitivities.
- ▶ To avoid the arbitrary nature of charges due to historic or geographical reasons a standard expansion factor could be applied to all assets regardless of voltage or type.

Summary of discrimination in HVDC charging

- ▶ AC networks require substations to function and transmit power. The substation house switchgear and protection, transformers, reactors, capacitors, Statcoms, series capacitors and quad boosters which are required to deliver power transfer of AC. These assets are not charged to the expansion factors whereas HVDC converters are.
- ▶ 50%-90% of the costs of building/reinforcing AC networks, are not included in AC the expansion factors.
- ▶ AC networks require ancillary services to operate them including reactive power, dynamic voltage control, inter-tripping etc. These costs re not incurred on HVDC links.
- ▶ OFTO developers control the sizing of their assets and can cost optimise, inland generation developers cannot.
- ▶ HVDC transmission links provide security of supply on remote islands
- ▶ The nature of network charging is somewhat arbitrary, whilst generally cost reflective there are instances when this is not the case. A standard km based expansion factor regardless of circuit voltage or type would remove such idiosyncrasies.

WACMs (workgroup alternative code modifications)

1. Remove all converter station costs from HVDC charging.
2. For Island HVDC charges, recognise the alternatives of making a supply to the islands via distribution rated HVDC and subtract this benefit from the cost before applying TNUOS. As these costs are clear for Shetland use Shetland as the model and apply same %ages to HVDC link to the Western Isles.
3. Given the discrepancies in charging and the historical and geographical accidents and associated costs relating to either: the remote islands; or the densely populated areas of England; or the landscape designations; apply a single global GB expansion factor to all assets: AC and DC; cable and overhead line; and all voltages; to remove these idiosyncrasies.
4. Combine 1&2 above
5. Combine 2&3 above.



THANK YOU

Guy Nicholson, Grid Manager

Guy.Nicholson@Statkraft.com



Statkraft
PURE ENERGY

www.statkraft.com

19 Annex 6: Alternative Request forms

CUSC WORKGROUP ALTERNATIVE REQUEST FORM

Respondent Name and contact details	Garth Graham (garth.graham@sse.com)
CMP303	WACM1
Capacity in which the WG Consultation Alternative Request is being raised : (i.e. CUSC Party, BSC Party or “National Consumer Council ”)	CUSC Party
<p>Description of the Proposal for the Workgroup to consider (<i>mandatory by proposer</i>):</p> <p>[WACM1]</p> <p>This Alternative will only apply half the cost of HVDC convertor station(s) to be recovered via the local circuit charge, with the balance being recovered via the Residual.</p> <p>The information within the CMP213 Final Modification Report ¹ and Annexes² identified:</p> <p><i>“that approximately half of the basic cost elements of the HVDC converter station have characteristics equivalent to AC and the other half to DC”</i> [paragraph 5.27 Vol 1]</p> <p>This view was reached, by the CMP213 Workgroup, after consideration of some external analysis which was set out in the Annexes to their report:</p> <p><i>“Based upon the analysis of the 2001 Cigre paper (186) a case has been made for the exclusion of 50% of the costs of a typical converter station as these elements perform a similar function to those of AC transmission substations (sections 5.32 to 5.35 of the Workgroup report). This conclusion remains consistent with the updated 2009 Cigre paper (388) and also the 2012 PB Power Electricity Transmission Costing Study which reference the same cost breakdown.”</i> [page 210, Vol 2]</p> <p>However, it should be noted that the CMP213 Workgroup did not just rely on these external sources of analysis alone - they also sought further cost information from a convertor station provider, which noted that:</p> <p><i>“Detailed converter cost information has also been sought from technology suppliers. However, concerns were expressed on the confidential nature of such detailed costing information. This level of detail has not been in the public domain previously as converters have been supplied under turnkey contracting arrangements as part of larger transmission projects. <u>A leading supplier has, however, confirmed that the Cigre cost breakdown is representative of the AC/DC equipment in both CSC and VSC technologies.</u>”</i> [emphasis added] [page 210, Vol 2]</p>	

¹ Volume 1 <https://www.nationalgrideso.com/sites/eso/files/documents/15494-Final%20CUSC%20Modification%20Report%20Volume%201.pdf>

² Volume 2 <https://www.nationalgrideso.com/sites/eso/files/documents/15495-Final%20CUSC%20Modification%20Report%20Volume%202%20-%20Annexes.pdf>

The CMP213 Workgroup therefore came to the view that:

“A robust case does therefore exist for the exclusion of 50% of the converter station costs for both CSC and VSC technologies.”

This Alternative is based on a fixed percentage figure (50%) being used to discount the cost of the convertor station(s) being recovered from the local circuit charge.

The benefits of applying a fixed percentage figure, rather than a non-fixed percentage figure calculated on a case by case basis was examined by the CMP213 Workgroup, who set out that:

“While it is accepted that there should be specific Expansion Factors for each HVDC circuit due to their varying lengths and therefore the differing proportion of cost split between the HVDC cable and the associated converter stations, it would provide a greater degree of stability and predictability to system users if the percentage of converter station costs to be included in the expansion factor was codified in advance.” [emphasis added] [page 210, Vol 2]

This Alternative would still apply the Original solution (in terms of the extra cost of bi-directional compared to mono-directional not being recovered from the local circuit etc.,)

Description of the difference(s) between your proposal compared to Original / Workgroup Alternative(s) *(mandatory by proposer):*

The difference with this Alternative compared to the Original is that it would allow for more cost reflective, predicable, stable and non-discriminatory transmission charging as the treatment of onshore AC and equivalent offshore HVDC transmission assets that exhibit the same characteristics would be treated in a similar charging manner.

Justification for the proposal (including why the Original proposal / Workgroup Alternative(s) does not address the defect) *(mandatory by proposer):*

This Alternative will allow for more cost reflective, predicable, stable and non-discriminatory transmission charging.

Impact on the CUSC *(this should be given where possible):*

Broadly the same as the Original.

Impact on Core Industry Documentation *(this should be given where possible):*

None.

Impact on Computer Systems and Processes used by CUSC Parties *(this should be given where possible):*

None.

Justification for the proposal with Reference to Applicable CUSC Objectives* (mandatory by proposer):

This Alternative proposal will better achieve Applicable Objectives for the same reasons as the Original.

In addition it will be better in terms of Applicable Objectives (b)³ as it allows for TNUoS charges to be more cost reflective than the Baseline (status quo) CUSC would allow.

Attachments (Yes/No):
If Yes, Title and No. of pages of each Attachment:

No.

Notes:

1. Applicable CUSC Objectives* - These are defined within the National Grid Electricity Transmission plc Licence under Standard Condition C10, paragraph 1. Reference should be made to this section when considering a proposed Modification.

³ (b) That compliance with the use of system charging methodology results in charges which reflect, as far as is reasonably practicable, the costs (excluding any payments between transmission licensees which are made under and accordance with the STC) incurred by transmission licensees in their transmission businesses and which are compatible with standard licence condition C26 requirements of a connect and manage connection);

CUSC WORKGROUP ALTERNATIVE REQUEST FORM

Respondent Name and contact details	Dr Nigel Scott Nigel.scott@xeroenergy.co.uk 0141 221 8556
CMP303 Improving local circuit charge cost-reflectivity	
Capacity in which the WG Consultation Alternative Request is being raised : (i.e. CUSC Party, BSC Party or "National Consumer Council ")	Working group member
Description of the Proposal for the Workgroup to consider <i>(mandatory by proposer):</i>	
This WACM 2 proposes to remove the cost of the HVDC converters from the costs entered into the generator local circuit TNUoS calculation on the basis that the normal onshore AC methodology does not include substations. The cost will be recovered via residual charges.	
Description of the difference(s) between your proposal compared to Original / Workgroup Alternative(s) <i>(mandatory by proposer):</i>	
The original proposal does not identify this aspect of HVDC links. This alternative should be applied in concurrence with the original proposal, whereby the bi-directional component of HVDC cost should not be recovered by generators to whom it is not relevant. However, this alternative will provide additional socialisation of HVDC costs, to better achieve the CUSC objectives, through recovery of HVDC converter costs via residual charges, in line with normal onshore AC methodology.	
Justification for the proposal <i>(including why the Original proposal / Workgroup Alternative(s) does not address the defect)</i> <i>(mandatory by proposer):</i>	
See also above. The original does not examine the treatment of HVDC substation costs and the disparity to normal onshore AC methodology.	
Impact on the CUSC <i>(this should be given where possible):</i>	
The proposal will improve cost reflectivity when calculating generator local circuit charges associated with HVAC subsea cable connections or new HVDC connections. The CUSC will need amendment at 14.15.75 and 14.15.76.	
Impact on Core Industry Documentation <i>(this should be given where possible):</i>	
This impacts the CUSC.	
Impact on Computer Systems and Processes used by CUSC Parties <i>(this should be given where possible):</i>	

Justification for the proposal with Reference to Applicable CUSC Objectives* (mandatory by proposer):

1. Competition. The proposal facilitates the relevant generators subject to the local circuit charges being able to compete more fairly in the market place.
2. Cost reflectivity. The proposal better reflects the costs incurred by the transmission parties (owners) that are relevant to the affected generators. It also recognises that certain costs (of substations) are not normally included in generator local circuit charges.
3. Transmission licensee business development. The proposal complements potential future changes to the transmission businesses by improving the charging basis for future HVDC works.
4. Compliance with regulations. Not affected.
5. Promoting efficiency in CUSC administration. Simplifies TNUoS calculations.

Attachments (Yes/No):
If Yes, Title and No. of pages of each Attachment:

Yes
Title - WACM 3 - Wider system benefits of HVDC (reference BRN 1234/028/001C)
Pages - 18

Notes:

1. Applicable CUSC Objectives* - These are defined within the National Grid Electricity Transmission plc Licence under Standard Condition C10, paragraph 1. Reference should be made to this section when considering a proposed Modification.

CUSC WORKGROUP ALTERNATIVE REQUEST FORM

CUSC WORKGROUP ALTERNATIVE REQUEST FORM	
Respondent Name and contact details	Dr Nigel Scott Nigel.scott@xeroenergy.co.uk 0141 221 8556
CMP303 Improving local circuit charge cost-reflectivity	
Capacity in which the WG Consultation Alternative Request is being raised : (i.e. CUSC Party, BSC Party or "National Consumer Council ")	Working group member
<p>Description of the Proposal for the Workgroup to consider <i>(mandatory by proposer):</i></p> <p>This WACM 3 identifies additional functionality of HVDC local circuits that is unrelated to the needs of the generation whose export is facilitated by the HVDC local circuits. It proposes to quantify the costs of this additional functionality by examining the costs of equivalent plant or services. The costs of the equivalent plant or services are then deducted from the HVDC costs entered into the generator local circuit TNUoS charge calculation to reduce the charge the relevant generators pay. The additional functionality is as follows.</p> <ol style="list-style-type: none"> 1. Reactive power provision 2. Voltage control 3. Power flow control (quadrature booster functionality) 4. Black start 	
<p>Description of the difference(s) between your proposal compared to Original / Workgroup Alternative(s) <i>(mandatory by proposer):</i></p> <p>The original does not identify this aspect of HVDC links. The alternative 2 proposes to remove the cost of the HVDC converters from the costs entered into the generator local circuit TNUoS calculation on the basis that the normal onshore methodology does not include substations. This alternative examines the actual wider system benefits and associated costs of HVDC and so sets out a case specific and clearly justified basis for cost removal.</p>	
<p>Justification for the proposal (<u>including why the Original proposal / Workgroup Alternative(s) does not address the defect</u>) <i>(mandatory by proposer):</i></p> <p>See also above. The original and other alternative 2 do not examine the actual wider system benefits of HVDC or the costs.</p>	
<p>Impact on the CUSC <i>(this should be given where possible):</i></p> <p>The proposal will improve cost reflectivity when calculating generator local circuit charges associated with HVAC subsea cable connections or new HVDC connections. The CUSC will need amendment at 14.15.75 and 14.15.76.</p>	
<p>Impact on Core Industry Documentation <i>(this should be given where possible):</i></p> <p>This impacts the CUSC.</p>	

Impact on Computer Systems and Processes used by CUSC Parties *(this should be given where possible):*

Justification for the proposal with Reference to Applicable CUSC Objectives* *(mandatory by proposer):*

1. Competition. The proposal facilitates the relevant generators subject to the local circuit charges being able to compete more fairly in the market place.
2. Cost reflectivity. The proposal better reflects the costs incurred by the transmission parties (owners) that are relevant to the affected generators. It also recognises that certain costs (of the wider system benefits) are not normally included in generator local circuit charges.
3. Transmission licensee business development. The proposal complements potential future changes to the transmission businesses by improving the charging basis for future HVDC works. It also recognises the benefits the transmission owners receive from HVDC.
4. Compliance with regulations. Not affected.
5. Promoting efficiency in CUSC administration. Not affected.

Attachments (Yes/No):
If Yes, Title and No. of pages of each Attachment:

Yes
Title - WACM 3 - Wider system benefits of HVDC (reference BRN 1234/028/001C)
Pages - 18

Notes:

1. Applicable CUSC Objectives* - These are defined within the National Grid Electricity Transmission plc Licence under Standard Condition C10, paragraph 1. Reference should be made to this section when considering a proposed Modification.



Xero Energy Limited
60 Elliot Street
Glasgow G3 8DZ
United Kingdom
Tel: +44 (0)141 221 8556
www.xeroenergy.co.uk
Reg. SC313697 in Scotland

BRIEFING NOTE

PROJECT: CMP 303
SUBJECT: WACM 3 - Wider system benefits of HVDC
CLIENT: Not applicable
REFERENCE: BRN 1234/028/001C
CLIENT REFERENCE: Not applicable

Document History

V	AUTH	VERF	APPR	DATE	NOTES
A	NCS	ES	NCS	28/11/2018	Draft version only.
B	NCS	FW	NCS	05/12/2018	First draft issue for CMP 303 working group only.
C	NCS	FW	NCS	04/02/2019	Updated WACM references

Notes

This document and any accompanying documents are to be distributed to members within the named client organisation only and are not to be distributed to other third parties or the public without express written consent from Xero Energy Limited. Xero Energy Limited does not accept responsibility for the application or use made of information or advice supplied. Such responsibility remains with the client.

1 Introduction

1.1 General

This short note has been drafted by Dr Nigel Scott of Xero Energy Limited to constitute and explain a WACM to the CMP 303 process. This WACM is 3.

The original CMP 303 text identifies the CUSC defect as follows.

When a new local circuit is built to enable the export of new generation, extra costs may be incurred on additional functionality that is unrelated to the needs of said generation. ... Absent clarification of the exclusion of these extra costs, they are very likely to be included in the actual costs used to calculate the expansion factor and hence the relevant local circuit charge, meaning that relevant generators are facing a local circuit charge that is not fully cost-reflective.

The proposed amended CUSC text is as follows.

14.15.75 AC sub-sea cable and HVDC circuit expansion factors are calculated on a case by case basis using actual project costs (Specific Circuit Expansion Factors), except that these project costs should only include costs relevant to and needed by the connected generators. The incremental cost of any extra functionality that the TO chooses to add, of wider benefit, should not be included.

14.15.76 Subject to 14.15.75, for HVDC circuit expansion factors both the cost of the converters and the cost of the cable are included in the calculation

1.2 Overview of WACM 3

This WACM 3 identifies additional functionality of HVDC local circuits that is unrelated to the needs of the generation whose export is facilitated by the HVDC local circuits. It proposes to quantify the costs of this additional functionality by examining the costs of equivalent plant or services. The costs of the equivalent plant or services are then deducted from the HVDC costs entered into the generator local circuit TNUoS charge calculation to reduce the charge the relevant generators pay.

1.3 Overview of additional functionality

1.3.1 Included in this note

The additional functionality identified and discussed further in this note is as follows.

1. Reactive power provision
2. Voltage control
3. Power flow control (quadrature booster functionality)
4. Black start

The additional functionality is provided as part of the HVDC link and provides wider transmission (and whole system) benefits, which are unrelated to the needs of the generators. Were this functionality provided separately, it would have a cost associated with it. This cost should therefore be removed from the generator local circuit charges as it is not relevant to the generator and presents a benefit to the wider system, which the relevant HVDC local circuit generators should not be paying for.

1.3.2 Excluded from this note

It should be noted that there is other functionality that could be considered additional, but at present this note is focused on the above as these are expected to be the key additional functions which constitute the largest costs. Such other additional functionality includes items such as power quality improvement, fault level boosting, stability control and more. A non-exhaustive list of other functionality is included as Appendix A.

It should further be noted that other proposals under CMP 303 cover the aspect of import or demand supply as additional functionality. This note therefore assumes that aspects related to this, such as demand security, reinforcement avoidance and standby diesel generator displacement/replacement, are effectively covered elsewhere.

1.4 Contents of this note

This note is set out as follows.

- Section 1 – Introduction (this section)
- Section 2 – HVDC TNUoS charging history
- Section 3 – Additional functionality
- Section 4 – Quantifying the costs
- Section 5 – Summary and conclusions
- Section 6 – References
- Section 7 – Appendix A – Other benefits of HVDC
- Section 8 – Appendix B - Acronyms

2 HVDC TNUoS charging history

2.1 General

Until recently, there were no HVDC links within the GB transmission system, only interconnections from other jurisdictions. Therefore, local circuit use of system charging of HVDC links has only been considered in this context, and in relatively simple and narrow terms.

2.2 Project TransmiT

Between 2010 and 2012, a review (Project TransmiT) of transmission use of system charging arrangements (TNUoS) for generators was undertaken by the regulator, Ofgem. This was primarily driven by the increase of intermittent wind generation in relatively remote locations such as Scotland. This work resulted in a change to the general charging arrangements and ultimately to the current local circuit treatment of HVDC links. The focus of this review was not however the treatment of HVDC, although it did feature.

In 2011, and as part of Project TransmiT, Ofgem considered whether HVDC converter station costs should be excluded when calculating wider tariffs where the link is in parallel with the existing system [1]. Ofgem consulted on this in May 2012 and subsequently directed National Grid to consider this case along with the wider benefits and costs relating to local circuit links as part of a CUSC modification process to revise charging arrangements [2]. This became the CMP213 process led by National Grid, with the focus again on the general use of system charging arrangements and not the treatment of HVDC, although it was duly considered.

2.3 CMP213

CMP213 was the National Grid led industry process to modify the charging arrangements as a follow up to Project TransmiT. As part of the initial scoping of options, National Grid examined cases where various percentages of the HVDC converter station costs were socialised [3] [4]. These cases were considered for both bootstrap (parallel) and local circuit (radial) HVDC links.

National Grid published a working group report in June 2013 which included a section on the wider benefits of Voltage Source HVDC with specific reference to the wider benefits of the Western Isles HVDC link [5]. This section was primarily based on a paper by SSE and ABB and set out a list of benefits. Despite the evidence provided in this National Grid assessment, and counter to its considerations published in March 2012, Ofgem came to a view in August 2013 [6] that socialisation of converter costs was not appropriate.

The consultation responses received by Ofgem did highlight a wide variety of potential wider benefits from HVDC, but it seems that the benefits were not quantified and there was insufficient appetite to pursue them given the focus of CMP213 was on the more general charging arrangements and this in itself was a major issue for industry. Ofgem did however note that it was open to further evidence on the wider system benefits of HVDC.

The wider system benefits from HVDC were again touched on during a further consultation round in April 2014 [7] with a number of respondents again highlighting the wider benefits. In its July 2014 decision [8], Ofgem again stated it had not seen enough evidence to further consider socialisation of HVDC (converter) costs. Ofgem additionally considered that wider socio-economic benefits were beyond its remit and suggested National Grid and industry tackle the issues around the wider benefits of HVDC at a later and more appropriate date [7].

2.4 Post CMP213

The charging arrangements that CMP213 developed have been implemented and there have been a wide variety of amendments to them over the last few years. There has however been little follow up to the CMP213 discussions on HVDC wider benefits and charging, bar the CMP301 CUSC clarification still in process at time of writing. Given there are now two operational HVDC links in the GB system and further parallel and radial local circuit HVDC links are likely, it would seem an appropriate time to revisit the charging arrangements for HVDC.

2.5 Current charging position

In calculating the local circuit generator charge from an HVDC link, Section 14 of the CUSC requires that the cost of the converters and cables is used.

In comparing the HVDC charging regime to the onshore charging regime for AC systems it can be seen that the AC regime is quite different in that no substation assets are normally included, just the overhead line or underground cable circuits themselves. Indeed, the relevant AC substation assets which would be needed to provide the additional functionality that the HVDC links bring are not included in local circuit charges (or wider zonal charges). This discrepancy suggests that there is an issue that needs to be addressed in making the current HVDC local circuit charging regime more cost reflective and the overall charging regime less discriminatory against HVDC systems and the users (generators) paying for them more directly through local circuit charges.

3 Additional functionality

3.1 Introduction

This section of the report examines four categories of additional functionality that a typical local circuit HVDC link provides. This note is focused on the more modern Voltage Source Converter technology which has just been installed to interconnect northern and north-eastern Scotland across the Moray Firth, i.e. Caithness-Moray HVDC link, and may be rolled out for other mainland to mainland transmission system uses. It is also proposed for various local circuit uses, e.g. the Western Isles of Scotland and Shetland.

3.2 Reactive power

National Grid is seeing an increasing need to absorb reactive power. This is a result of increased embedded generation and demand reductions leading to a lightly loaded transmission system producing excess reactive power. This is a localised issue but National Grid reports this is seen in all regions.

In addition to this, there is a need to be able to provide reactive power and vary the amount either provided or absorbed for various reasons.

An HVDC link will be very capable at providing reactive power services. These can be provided at both ends of the link by the converters. The equivalent devices to provide a reactive power capability similar to the HVDC converters, where an HVDC link is not present, are such as an SVC, STATCOM and similar FACTS devices.

3.3 Voltage support

The provision of reactive power also is important in providing the various voltage support services that National Grid requires. This is similarly a localised issue, but with similar trends to reactive power issues across the regions of the GB transmission system.

As with reactive power provision, an HVDC link will be very capable of providing voltage support services at both ends of the link. The equivalent devices to provide voltage support where an HVDC link is not present are also similar.

For both reactive power and voltage support it should be noted that the type of requirements will dictate the type of device. As an HVDC converter is very flexible and dynamic then a suitable equivalent would be a STATCOM or similar power electronics FACTS device, but not fixed capacitors and reactors.

3.4 Power flow control (quadrature booster function)

An HVDC link can control how much power flows through it and hence how much must flow through other circuits which may be in parallel. This offers an operational benefit similar to a quadrature booster in an AC network, something also noted during the Project TransmiT and CMP213 consultation responses. A quadrature booster would provide an equivalent capability on an AC system.

A quadrature booster is a device typically constructed from two transformers, though some versions can be constructed using only one transformer. They have been in use on the GB transmission system for many decades and their behaviour and characteristics are well understood. A quadrature booster acts to control the transfer of power along parallel routes in the transmission system and can therefore control power flows and other system characteristics beyond what would otherwise be possible in an AC system.

The principle of operation is that the quad booster adds an out of phase voltage, of controllable magnitude, to the prevailing voltage of the circuit and thereby causes a controllable shift in the phase angle of the resultant voltage. It is this phase angle which determines the transfer of power along the circuit.

3.5 Black start

Black start service provision has traditionally been provided by large synchronous generators which are flexible enough to provide both balancing and frequency response, and, reactive power and voltage support. Black start involves bringing the system back up after a blackout event. VSC HVDC technology can provide black start capability at either end, provided the other end is up and running and can source real power as required.

In recent years, black start provision has been an issue and service provision costs have been very high. Black start is also a significant issue in Scotland given the lack of plant capable of offering the service.

There is no readily available economic equivalent device to provide black start at present and this capability would normally be purchased from (large synchronous) generators. National Grid is however looking at other types of service provider as the availability of suitable large synchronous generators has waned over recent times.

4 Quantifying the costs

4.1 Introduction

This section examines the costs associated with the additional functionality and hence the costs that should be removed from the generator local circuit charges associated with an HVDC link.

Whilst the general method used could be applied to any case, it is easier to understand the order of costs and the resultant generator local circuit charge reduction by way of an example.

4.2 Example using an HVDC link

Whilst the general method used could be applied to any case, it is easiest to understand the order of costs and the resultant generator local circuit charge reduction by way of an example. For the purposes of this note, an HVDC link is used. Costs used are assumed and approximate and are based on proposals for Shetland [9, 10] and the Western Isles [11, 12].

The example considers a 600MW HVDC VSC link at a total cost of £700 million assumed to be broken down as follows.

- HVDC Converters £300 million
- HVDC cable circuit £300 million
- HVAC substation assets (switchgear, transformers, etc) £100 million

The overall HVDC converter and cable costs are entered into the local circuit TNUoS calculation as per the current CUSC methodology. This means that £600 million is entered into the local circuit TNUoS calculation giving a local circuit TNUoS charge to the generators of £76 per kW per annum.

It should be noted that non-asset specific costs such as development and consenting costs, insurance and project management are likely to be included in the above figures. These costs are normally allocated pro-rata over the HVDC and HVAC assets as per common practice.

The following estimates of cost for equivalent plant to provide the additional functionality do not allow for non-asset specific costs (e.g. development costs). This should be taken into account but as the non-asset specific costs in the example used above are not known, this is not possible. Therefore the cost reductions shown in this note will not fully reflect the costs that should be removed and will be less than if the non-asset specific costs were known.

4.3 Reactive power and voltage control

4.3.1 Equivalent costs

To provide the equivalent cost for reactive power and voltage control, the below examines the cost of a STATCOM or similar device. This device (or similar) can provide both functions and is reflective of the capability of the HVDC converter(s).

It is assumed that each end of the HVDC link can provide this capability up to the rating of the link. In the case of Shetland and the Western Isles it is assumed this means a dynamic reactive power and voltage control capability at either end of up to 600MVar.

The cost for an equivalent 600MVar device is estimated at around £90 million to £110 million depending on the type and specification of the device(s). This excludes transformers and switchgear to take the device up to transmission voltage and hence the cost estimate can be more or less directly compared to an HVDC converter cost (one only) at £150 million.

For reference purposes, the interconnecting switchgear, transformers and associated other plant to connect from a medium voltage up to transmission voltage are estimated at £20 million to £55 million depending on the transmission voltage, e.g. 132kV, 275kV or 400kV, and the exact specification of the plant. This plant cost is assumed to not be included as it is akin to the AC substation plant excluded from the HVDC local circuit calculation under the current version of the CUSC.

4.3.2 Generator local circuit calculation

Taking the Shetland and the Western Isles HVDC link examples and making an average cost debit of £100 million from both ends of the HVDC link would reduce the eligible converter costs from £300 million to £100 million. Therefore, the total cost entered into the local circuit TNUoS calculation is reduced to £400 million giving a local circuit TNUoS charge to the generators of £51 per kW per annum.

4.3.3 Issues to consider

There is a need to consider the utility of a 600MVar device at the two locations.

There is also a query over the overall utilisation factor and the ability to run up to 600MVar when under MW load for an HVDC link.

4.4 Power flow control (quadrature booster function)

4.4.1 Equivalent costs

To provide the equivalent cost for power flow control, the cost of a quadrature booster is examined below. As the HVDC link cannot perform this function independently at each end, only one quadrature booster would be required to provide the equivalent function of the whole HVDC link.

Taking the Shetland and Western Isles example, XE estimates the cost of a quadrature booster, suitable for the control of 600MVA, at around £5 million to £10 million depending on the transmission voltage, e.g. 132kV, 275kV or 400kV and exact specification of plant.

As a quadrature booster interfaces directly to the transmission system circuit, it is difficult to separate out costs of the plant equivalent to an HVDC converter from the transformers and switchgear which are an integral part of the quadrature booster.

4.4.2 Generator local circuit calculation

Taking the Shetland and Western Isles HVDC link examples and making an average cost debit of £7.5 million from the HVDC link for one quadrature booster would reduce the eligible converter costs from £300 million to £292.5 million. Therefore, the total cost entered into the local circuit TNUoS calculation is reduced to £592.5 million giving a local circuit TNUoS charge to the generators of £75 per kW per annum.

4.4.3 Issues to consider

In the case of an HVDC link interconnecting two systems at different voltages it will be less expensive to provide the quadrature booster at the end which is at a lower voltage, assuming this is practical and there are no other technical reasons not to do this.

There is also a need to consider the necessary rating of the quadrature booster to provide the required function.

4.5 Black start

4.5.1 Equivalent costs

During 2017/18, National Grid incurred total costs of £57.7 million for the provision of Black Start [13] across fifteen Black Start Units [14] [15] [16]. Therefore, the average expenditure during 2017/18 was approximately £3.8m per Black Start Unit. The overall size/capability of these individual units cannot be readily confirmed through publicly available information.

Based on very high-level analysis, a 600MW HVDC link could provide an annual network value of at least £1 million to £4 million based on National Grid's approximate spend on the current fleet of Black Start units. However, as seen in recent years, the increasing scarcity of black start units could increase this system value and cost significantly.

Assuming a 50 year lifetime for the HVDC link, as reflected in the generator local circuit calculations, and ignoring any financial manipulation gives a very rough net present value of around £125 million. A more complete financial analysis is beyond the scope of this paper and an appropriate financial method and variables for this should ideally be provided by National Grid. In the meantime, it should thus be appreciated that the £125 million estimate could be significantly amended, but nonetheless will likely still be a significant cost.

4.5.2 Generator local circuit calculation

Taking the Shetland and Western Isles HVDC link examples and making a cost debit of £125 million from the HVDC link would reduce the eligible converter costs from £300 million to £175 million. Therefore, the total cost entered into the local circuit TNUoS calculation is reduced to £475 million giving a local circuit TNUoS charge to the generators of £60 per kW per annum.

4.5.3 Issues to consider

There are a number of issues to consider for Black start.

Unlike reactive power provision, voltage control and quadrature booster function, there is no equivalent plant that can be examined to understand cost and value. For black start, service provision costs need to be examined. These costs have shown very significant variations in recent years due to closures (or proposed mothballing) of traditional providers of black start, i.e. large thermal synchronous power stations. This means a definitive cost is virtually impossible to determine.

Another key issue with the HVDC link providing black start is that it must source its real power from a live system and ultimately generators which must respond accordingly to the demands of the HVDC link and system being restored.

Finally, once an equivalent annual service cost has been determined, this figure needs to be manipulated to an equivalent net present value or lump sum to allow it to be debited directly from the HVDC costs. How this is done is also open to interpretation.

5 Summary and conclusions

5.1 General

This short note has briefly outlined a number of the additional functions that are provided with a VSC HVDC link in the transmission system and that are not necessarily required for generators using the link.

These additional functions have costs associated with them and thus, these costs should be deducted from the costs entered into the local circuit generator TNUoS calculation. This will provide a more cost reflective charge to the generators and better reflect the wider system costs and benefits where such equivalent plant cost is normally socialised or recovered through other means.

5.2 Additional functions

The additional functions examined herein are as follows.

- Reactive power provision
- Voltage control
- Power control (quadrature booster function)
- Black start

There are also other functions that the VSC HVDC link can provide and could be examined also. These are briefly highlighted in Appendix A.

5.3 Equivalent plant costs

For each function, it is proposed that the cost of the equivalent plant is established and deducted from the relevant costs of the HDVC link that are entered into the generator local circuit TNUoS calculation. For the case of reactive power and voltage control, it is proposed to cost SVC, STATCOM or similar plant at both ends of the HVDC link. For the case of power control, it is proposed to cost a quadrature booster. For the case of black start, there is no equivalent plant as such and the costs of providing or procuring the service need to be used.

5.4 Cost example

The proposed 600MW Shetland and Western Isles HVDC links have been used as an example, with equivalent plant and service costs determined and deducted from the relevant costs of the HDVC link that are entered into the generator local circuit TNUoS calculation.

Table 5-1 below sets out the approximate costs of the Shetland and Western Isles HVDC links and resultant generator local circuit TNUoS. It then shows the order of capital cost reduction due to the four functions (reactive power and voltage control are treated as one) and the resultant generator local circuit TNUoS reduction. The final column looks at the impact on cost and generator local circuit TNUoS with all four functions taken together.

Item	Costs, £ million				
	Shetland and Western Isles HVDC links	Reactive power & voltage control	Quadrature booster	Black Start	All 4 functions
Equivalent plant (debit)	-	(200)	(7.5)	(125)	(332.5)
HVDC converters	300	300	300	300	300
HVDC cables	300	300	300	300	300
HVAC assets	100	100	100	100	100
Total for TNUoS	600	400	592.5	475	267.5
TNUoS, £/kW/annum	76	51	75	60	34

Table 5-1: Summary of costs and generator local circuit TNUoS tariffs

5.5 Conclusions

5.5.1 WACM 3

This paper has presented a rationale and method to reduce the costs entered into generator local circuit TNUoS calculations where HVDC links are proposed. This is WACM 3. It is proposed that the relevant costs are removed on a case by case basis.

In the example used, this results in a cost deduction that exceeds the cost of the HVDC converters. This highlights the high value to the wider system that the HVDC converters bring and the importance of recognising this value.

As the cost debit is around the cost of the HVDC converters, this WACM 3 methodology, and WACM 2, effectively remove all substation costs from the calculation of the TNUoS. This aligns closely to the existing onshore method where substation costs are socialised, and only underground cables and overhead lines are of interest.

It should be recognised that the calculations presented are based on various assumptions and that the calculation basis needs to be clearly established and agreed. This will lead to some changes to the estimated equivalent costs and estimated generator local circuit TNUoS tariffs.

Further to the above, it is recommended that other examples should be considered to assess whether the methodology is suitably reproducible, and the findings appropriate across different HVDC links.

Finally, it should be noted that there is other functionality that an HVDC link provides that is relevant to the above but not addressed in this paper.

5.5.2 WACM 2

Although not the subject of this note, WACM 2 proposes that the cost of the HVDC converters is removed from the generator local circuit TNUoS calculation entirely. The analysis of this note also supports this proposal. Simply removing the cost of the HVDC converters in total and without recourse to any other calculation has the additional and significant benefit of simplifying the whole calculation process by removing the need to identify the costs of the additional functionality along with all the assumptions and considerations that need to be addressed and are somewhat debatable. As noted above, this also aligns the calculation of the TNUoS closely to the existing onshore method where substation costs are socialised, and only underground cables and overhead lines are of interest.

6 References

- [1] Ofgem, "Electricity transmission charging: assessment of options for change", 20 December 2011.
- [2] Ofgem, "Electricity transmission charging arrangements: Significant Code Review conclusions", 04 May 2012.
- [3] National Grid, "Stage 02: Workgroup Consultation - CMP213 Project TransmiT TNUoS Developments", 07 December 2012.
- [4] National Grid, "Stage 04: Code Administrator Consultation - Volume 1 - CMP213 Project TransmiT TNUoS Developments", 10 April 2013.
- [5] National Grid, "Stage 06: Final CUSC Modification Report - Volume 2 - CMP213 Project TransmiT TNUoS Developments - Annexes", 14 June 2013.
- [6] Ofgem, "Project TransmiT: Impact Assessment of industry's proposals (CMP213) to change the electricity transmission charging methodology", 01 August 2013.
- [7] Ofgem, "Project TransmiT: Further consultation on proposals to change the electricity transmission charging methodology", 25 April 2014.
- [8] Ofgem, "Project TransmiT: Decision on proposals to change the electricity transmission charging methodology", 25 July 2014.
- [9] Scottish and Southern Energy Power Distribution plc, "Shetland HVDC Link Consultation", August 2016.
- [10] P. Wheelhouse, "Renewables", in *Scottish Parliament*, Edinburgh, December 2016.
- [11] Scottish & Southern Electricity Network, "Western Isles HVDC Link Consultation", 2017.
- [12] Subsea World News, "Western Isles HVDC Link Costs Rise (UK)", Subsea World News, 05 December 2012. [Online]. Available: subseaworldnews.com. [Accessed 04 December 2018].
- [13] National Grid ESO, "Black Start Allowed Revenue", April 2018.
- [14] National Grid, "Monthly Balancing Services 2017/18", January 2018.
- [15] National Grid, "Monthly Balancing Services 2017/18", February 2018.
- [16] National Grid, "Monthly Balancing Services 2017/18", March 2018.
- [17] National Grid, "System Operability Framework", November 2016.
- [18] Baringa, "Scottish Islands Renewable Project", 14 May 2013.

7 Appendix A - Other benefits of HVDC

7.1 General

This section briefly highlights other potential wider system benefits of HVDC.

7.2 Other wider system benefits of HVDC

7.2.1 Short circuit level

A VSC HVDC link can work with low network fault levels, such as on the Scottish islands. It also offers some uplift in fault level, albeit limited to about the rating of the link.

7.2.2 Increased fault level- power quality and stability

Low fault levels result in many issues such as power quality, protection difficulties and stability problems. National Grid has identified a drop-in network fault levels as a problem on the main transmission system [17].

The existing fault levels on the Scottish islands are already very low as a result of electrical remoteness or high circuit impedance back to the main transmission system on the mainland. The addition of the proposed HVDC link will increase fault levels and the additional generation it facilitates will also increase fault levels. The level of increase will also depend in part on how the new HVDC link and existing system are configured.

7.2.3 Balancing and frequency response

In addition to improving security of supply, the HVDC link can provide a balancing and frequency response function to isolated ends. The HVDC link itself cannot provide real power and so this assumes it can source the necessary variable real power from one end, so as to provide the service at the other end. For the Scottish islands, the implication is that this is provided by mainland generators.

7.2.4 Socio-economic impacts

The socio-economic uplift to regions connected via HVDC links or other has been noted in the past. This issue was also addressed in 2013 through an independent report [18]. The report concluded that development of renewable generation on the Scottish islands could have significant benefits to both the local island economy, the rest of Scotland and elsewhere in the UK. There would also be facilitation of further marine renewables development to the benefit of UK businesses involved in the sector.

The report further concluded the development of island renewable generation would bring carbon and fuel savings. For the Western Isles and Shetland this would be facilitated by the VSC HVDC links.

The report also concluded that the island renewable generation and associated transmission links could provide further benefits related to local security of supply, whilst the diversity benefits of developing renewables on the islands (especially marine) could reduce the overall cost of intermittency on the GB system.

7.2.5 Promotion of new renewables and sustainability

Currently, both installed HVDC links primarily facilitate further deployment of renewable energy in Scotland. This would appear to be similar for the currently proposed HVDC links and a number of possible future links. This meets the political sustainability agenda for renewable energy.

7.2.6 Reduction in future HVDC costs through learning

During Project TransmiT it was considered that there would be some wider benefit to install HVDC links now in terms of learning and future cost reductions. This is based on the premise that HVDC links will become much more prevalent in future.

7.2.7 Power oscillation damping

The VSC HVDC link can provide power system stabilisation and in particular be used to damp down power oscillations. This is a concern of National Grid and requirements to consider this and act against it have been introduced in recent years.

7.2.8 Power quality (flicker, unbalance and harmonics)

The fast-reactive capability of the VSC HVDC link can be used to reduce voltage flicker and reduce or eliminate certain voltage harmonics and voltage unbalance. This can provide a direct improvement in power quality.

7.2.9 System inertia

While power electronic converters do not themselves provide any inertia, they can be programmed to provide synthetic inertia. Reducing inertia is a problem on the transmission system [17] and results in various issues such as reduced stability.

8 Appendix B - Acronyms

Acronym	Definition
CMP	CUSC Modification Proposal
CUSC	Connection and Use of System Code
FACTS	Flexible Alternating Current Transmission Systems
GB	Great Britain
HVAC	High Voltage Alternating Current
HVDC	High Voltage Direct Current
kV	Kilovolt
MVAr	Megavolt Ampere reactive
MW	Megawatt
Ofgem	Office of Gas and Electricity Markets
Quadrature booster	Phase Angle Regulating Transformer
STATCOM	Static Synchronous Compensator
SVC	Static Volt Ampere Reactive Compensator
TNUoS	Transmission Network Use of System (charges)
VSC	Voltage Source Converter
WACM	Workgroup Alternative CUSC Modification proposal

CUSC WORKGROUP ALTERNATIVE REQUEST FORM

CUSC WORKGROUP ALTERNATIVE REQUEST FORM	
Respondent Name and contact details	<i>Garth Graham (garth.graham@sse.com)</i>
CMP303	WACM4
Capacity in which the WG Consultation Alternative Request is being raised : (i.e. CUSC Party, BSC Party or "National Consumer Council ")	CUSC Party
<p>Description of the Proposal for the Workgroup to consider <i>(mandatory by proposer):</i></p> <p>[WACM4] The information within the SHEPD response to the Workgroup consultation along with the associated Workgroup Alternative Request Form from SHEPD identified that work is underway within the DSO to assess what, if any, value might be attributed to offset some of the cost of a transmission link in place of building a distribution link. The decision on whether that value figure is correct and then how, if appropriate, that should be recovered from relevant stakeholders is for Ofgem to determine. For the purposes of this Alternative the figure determined by Ofgem is referred to as £X.</p> <p>This Alternative would put in place a mechanism whereby an amount £Y, determined by Ofgem, could be recovered entirely from Demand TNUoS only.</p> <p>It is possible that Ofgem may determine that £X and £Y are one and the same figure. However, it is possible that Ofgem may determine that only a proportion of £X should be recovered via the £Y mechanism introduced (with this Alternative) into Section 14. The balance between £X and £Y (which we refer to as £Z) would, it is presumed, be recovered in another way (such as via DUoS?) but, for the avoidance of doubt, neither the amount £X or £Z form part of this Alternative per se. It is the figure for £Y that is included within Section 14 and recovered only from Demand TNUoS, and which this Alternative is focussed on.</p> <p>For the avoidance of doubt, the value of £Y could be determined, by Ofgem, as £0 (zero). This would allow the formulaic changes introduced by this Alternative to work, all be it that practically it would have no effect on Demand TNUoS.</p> <p>As with the value of MAR used within the Baseline Section 14; which is a number determined via the Regulatory settlement between Ofgem and the relevant TOs; so the value of £Y would, likewise, be determined by Ofgem in discussions with the relevant parties, and then reported to the ESO for them to use when determining TNUoS charges (as happens today with the MAR value).</p> <p>Taking two hypothetical examples to illustrate this, and assuming in both cases that TNUoS (absent the Distribution offset) was £2,500M (amount £A) and Ofgem determined that an offset should apply in terms of the value of the need associated with not building a distribution link but rather utilising a transmission link, then:</p> <p>Example 1. Ofgem determines that £X is £100M and that the value of £Y is the same (£100M). It was noted in</p>	

the Workgroup meeting that the U.K. Government had established a policy that the cost of the link to Shetland should be recovered from GB parties¹. This, for example, might be the reason why Ofgem determined that 100% of the Distribution offset (£X) should be recovered from Demand TNUoS via the £Y figure included, via this Alternative, in Section 14.

This Alternative would permit this to occur.

Thus the total amount to be recovered, via TNUoS, would be £2,600M (amount £B) which combines the requisite amounts for £X and £A.

Therefore, step one would see the ESO recovering the £Y figure (of £100M) from Demand TNUoS parties via a "Distribution Offset Uplift".

Step two would see the ESO recover the balance (the £A figure) from Demand and Generators TNUoS tariffs in the normal way.

As a result Demand TNUoS parties would pay a total of (i) the Distribution Offset Uplift and (ii) their share of TNUoS via the published tariff(s).

Example 2

This example is the same Example 1 in approach, it's just that the quantum is less. Thus, with this Example 2, Ofgem determines that £X is £100M and that the value of £Y is less than this; say 50%, so £50M

Thus the total amount to be recovered, via TNUoS, would be £2,550M (amount £B) which combines the requisite amounts for £X and £A.

Therefore, step one would see the ESO recovering the £Y figure (of £50M) from Demand TNUoS parties via a "Distribution Offset Uplift".

As with Example 1, step two would see the ESO recover the balance (the £A figure) from Demand and Generators TNUoS tariffs in the normal way.

This Alternative would still apply the Original solution (in terms of the extra cost of bi-directional compared to mono-directional not being recovered from the local circuit etc.,)

Description of the difference(s) between your proposal compared to Original / Workgroup Alternative(s) (mandatory by proposer):

The difference with this Alternative compared to the Original is that it would allow Ofgem to determine an £ amount, associated with the distribution needs being satisfied via the transmission link, that could be recovered from Demand TNUoS only.

Justification for the proposal (including why the Original proposal / Workgroup Alternative(s) does not address the defect) (mandatory by proposer):

¹ DECC July 2016 'HYDRO BENEFIT REPLACEMENT SCHEME & COMMON TARIFF OBLIGATION' document. Paragraph 1.3 "the full costs of the cross-subsidy for Shetland would be spread over Great Britain from the date at which the new energy solution for Shetland is implemented"
https://assets.publishing.service.gov.uk/government/uploads/system/uploads/attachment_data/file/534154/Government_Response_Hydro_Benefit_4_July.pdf

Commented [GG1]: This is based on Approach 2 in my email of Friday 25/1. With Approach 1 there would be a single step, to recover the amount £Y from Demand only.

<p>This Alternative will allow Ofgem to determine what, if any, amount of the cost associated with the building of HVDC transmission assets by the TO should be recovered from Demand TNUoS. It does not require that any amount should be recovered in this way; rather it facilitates this if Ofgem determines that that is the most appropriate way to proceed for the overall benefit of end consumers.</p>	
<p>Impact on the CUSC <i>(this should be given where possible):</i></p> <p>Broadly the same as the Original.</p>	
<p>Impact on Core Industry Documentation <i>(this should be given where possible):</i></p> <p>None.</p>	
<p>Impact on Computer Systems and Processes used by CUSC Parties <i>(this should be given where possible):</i></p> <p>None.</p>	
<p>Justification for the proposal with Reference to Applicable CUSC Objectives* <i>(mandatory by proposer):</i></p> <p>This Alternative proposal will better achieve Applicable Objectives for the same reasons as the Original.</p> <p>In addition it will be better in terms of Applicable Objectives (b)² and (c)³ as it allows for developments, such as that some of the needs of the Distribution network is provided by the Transmission network, whilst doing so in a more cost reflective way than the Baseline (status quo) CUSC would allow.</p>	
<p>Attachments (Yes/No): If Yes, Title and No. of pages of each Attachment:</p>	<p>No.</p>

Notes:

1. Applicable CUSC Objectives* - These are defined within the National Grid Electricity Transmission plc Licence under Standard Condition C10, paragraph 1. Reference should be made to this section when considering a proposed Modification.

² (b) That compliance with the use of system charging methodology results in charges which reflect, as far as is reasonably practicable, the costs (excluding any payments between transmission licensees which are made under and accordance with the STC) incurred by transmission licensees in their transmission businesses and which are compatible with standard licence condition C26 requirements of a connect and manage connection);

³ (c) That, so far as is consistent with sub-paragraphs (a) and (b), the use of system charging methodology, as far as is reasonably practicable, properly takes account of the developments in transmission licensees' transmission businesses;

CUSC WORKGROUP ALTERNATIVE REQUEST FORM

CUSC WORKGROUP ALTERNATIVE REQUEST FORM	
Respondent Name and contact details	<i>Garth Graham (garth.graham@sse.com)</i>
CMP303	WACM5
Capacity in which the WG Consultation Alternative Request is being raised : (i.e. CUSC Party, BSC Party or "National Consumer Council ")	CUSC Party
Description of the Proposal for the Workgroup to consider <i>(mandatory by proposer):</i>	
<p>[WACM5]</p> <p>This Alternative combines:</p> <p>(a) the WACM1 features (applying half the cost of HVDC convertor station(s) to be recovered via the local circuit charge, with the balance being recovered via the Residual); and</p> <p>(b) the WACM4 features (the recovery of a proportion of the cost of a transmission HVDC link equivalent to the needs of distribution from Demand TNUoS in the proportion(s) determined by Ofgem).</p> <p>This Alternative would still apply the Original solution (in terms of the extra cost of bi-directional compared to mono-directional not being recovered from the local circuit etc.,)</p>	
Description of the difference(s) between your proposal compared to Original / Workgroup Alternative(s) <i>(mandatory by proposer):</i>	
<p>The difference with this Alternative compared to the Original is the same as set out in WACMs 1 and 4.</p>	
Justification for the proposal <i>(including why the Original proposal / Workgroup Alternative(s) does not address the defect)</i> <i>(mandatory by proposer):</i>	
<p>The justification for this Alternative compared to the Original is the same as set out in WACMs 1 and 4.</p>	
Impact on the CUSC <i>(this should be given where possible):</i>	
<p>Broadly the same as the Original.</p>	
Impact on Core Industry Documentation <i>(this should be given where possible):</i>	
<p>None.</p>	

Impact on Computer Systems and Processes used by CUSC Parties *(this should be given where possible):*

None.

Justification for the proposal with Reference to Applicable CUSC Objectives* *(mandatory by proposer):*

This Alternative proposal will better achieve Applicable Objectives for the same reasons as the Original.

In addition the justification for this Alternative with reference to the Applicable Objectives is the same as set out in WACMs 1 and 4.

Attachments (Yes/No):
If Yes, Title and No. of pages of each Attachment:

No.

Notes:

1. Applicable CUSC Objectives* - These are defined within the National Grid Electricity Transmission plc Licence under Standard Condition C10, paragraph 1. Reference should be made to this section when considering a proposed Modification.

CUSC WORKGROUP ALTERNATIVE REQUEST FORM

CUSC WORKGROUP ALTERNATIVE REQUEST FORM	
Respondent Name and contact details	<p><i>Dr Nigel Scott</i> Nigel.scott@xeroenergy.co.uk 0141 221 8556</p>
CMP303 Improving local circuit charge cost-reflectivity	
Capacity in which the WG Consultation Alternative Request is being raised : (i.e. CUSC Party, BSC Party or "National Consumer Council ")	Working group member
<p>Description of the Proposal for the Workgroup to consider <i>(mandatory by proposer):</i></p> <p>This WACM 6 is a combination of WACM 2 and WACM 4.</p> <p>WACM 2 - to remove the cost of the HVDC converters from the costs entered into the generator local circuit TNUoS calculation on the basis that the normal onshore AC methodology does not include substations.</p> <p>WACM 4 - the recovery of a proportion of the cost of a transmission HVDC link equivalent to the needs of distribution from Demand TNUoS in the proportion(s) determined by Ofgem.</p> <p>This alternative should be applied in concurrence with the original proposal.</p>	
<p>Description of the difference(s) between your proposal compared to Original / Workgroup Alternative(s) <i>(mandatory by proposer):</i></p> <p>Same as those of WACM 2 and 4.</p>	
<p>Justification for the proposal (<u>including why the Original proposal / Workgroup Alternative(s) does not address the defect</u>) <i>(mandatory by proposer):</i></p> <p>Same as those of WACM 2 and 4.</p>	
<p>Impact on the CUSC <i>(this should be given where possible):</i></p> <p>Same as those of WACM 2 and 4.</p>	
<p>Impact on Core Industry Documentation <i>(this should be given where possible):</i></p> <p>Same as those of WACM 2 and 4.</p>	
<p>Impact on Computer Systems and Processes used by CUSC Parties <i>(this should be given where possible):</i></p>	

Justification for the proposal with Reference to Applicable CUSC Objectives* (*mandatory by proposer*):

Same as those of WACM 2 and 4.

Attachments (Yes/No):

If Yes, Title and No. of pages of each

Attachment:

Yes

Title - WACM 3 - Wider system benefits of HVDC
(reference BRN 1234/028/001C)

Pages - 18

Notes:

1. Applicable CUSC Objectives* - These are defined within the National Grid Electricity Transmission plc Licence under Standard Condition C10, paragraph 1. Reference should be made to this section when considering a proposed Modification.

CUSC WORKGROUP ALTERNATIVE REQUEST FORM

Respondent Name and contact details	<i>Dr Nigel Scott</i> Nigel.scott@xeroenergy.co.uk 0141 221 8556
CMP303 Improving local circuit charge cost-reflectivity	
Capacity in which the WG Consultation Alternative Request is being raised : (i.e. CUSC Party, BSC Party or "National Consumer Council ")	Working group member
Description of the Proposal for the Workgroup to consider <i>(mandatory by proposer):</i> This WACM 7 is a combination of WACM 3 and WACM 4. WACM 3 - to remove the cost of additional functionality of HVDC local circuits that is unrelated to the needs of the generation whose export is facilitated by the HVDC local circuits and to calculate these costs on a case by case basis. WACM 4 - the recovery of a proportion of the cost of a transmission HVDC link equivalent to the needs of distribution from Demand TNUoS in the proportion(s) determined by Ofgem. This alternative should be applied in concurrence with the original proposal.	
Description of the difference(s) between your proposal compared to Original / Workgroup Alternative(s) <i>(mandatory by proposer):</i> Same as those of WACM 3 and 4.	
Justification for the proposal <i>(including why the Original proposal / Workgroup Alternative(s) does not address the defect)</i> <i>(mandatory by proposer):</i> Same as those of WACM 3 and 4.	
Impact on the CUSC <i>(this should be given where possible):</i> Same as those of WACM 3 and 4.	
Impact on Core Industry Documentation <i>(this should be given where possible):</i> Same as those of WACM 3 and 4.	
Impact on Computer Systems and Processes used by CUSC Parties <i>(this should be given where possible):</i> (This section is currently blank)	

Justification for the proposal with Reference to Applicable CUSC Objectives* (*mandatory by proposer*):

Same as those of WACM 3 and 4.

Attachments (Yes/No):

If Yes, Title and No. of pages of each

Attachment:

Yes

Title - WACM 3 - Wider system benefits of HVDC
(reference BRN 1234/028/001C)

Pages - 18

Notes:

1. Applicable CUSC Objectives* - These are defined within the National Grid Electricity Transmission plc Licence under Standard Condition C10, paragraph 1. Reference should be made to this section when considering a proposed Modification.

CUSC WORKGROUP ALTERNATIVE REQUEST FORM

CUSC WORKGROUP ALTERNATIVE REQUEST FORM	
Respondent Name and contact details	<p><i>Dr Nigel Scott</i> Nigel.scott@xeroenergy.co.uk 0141 221 8556</p>
CMP303 Improving local circuit charge cost-reflectivity	
Capacity in which the WG Consultation Alternative Request is being raised : (i.e. CUSC Party, BSC Party or "National Consumer Council ")	Working group member
<p>Description of the Proposal for the Workgroup to consider <i>(mandatory by proposer):</i></p> <p>This alternative 8 identifies a method to quantify the necessary cost reduction to local circuit generator TNUoS charges as a result of the bidirectional nature of the local circuit, that bidirectional nature relating to import against the relevant generator's export for the purposes of demand and other.</p> <p>For HVAC subsea cable connections or new HVDC connections that constitute a generator local circuit for the purposes of TNUoS charging, the proportion of the costs of the connection for import flows (e.g. for demand, and export on to other localities) must be recognised and should not be charged to the relevant generators. This is achieved by deducting (pro-rata) a proportion of the cost of the connection from the relevant cost entered to the generator local circuit TNUoS calculation. This pro-rata proportion shall be calculated using the import / generation export ratio. The import shall be calculated based on the maximum anticipated import needs.</p>	
<p>Description of the difference(s) between your proposal compared to Original / Workgroup Alternative(s) <i>(mandatory by proposer):</i></p> <p>This alternative 8 uses a simple pro-rata method based on import and generator export flows to quantify the cost reduction for the purposes of generator local circuit charging. This avoids arguable and bespoke costing exercises.</p>	
<p>Justification for the proposal (<u>including why the Original proposal / Workgroup Alternative(s) does not address the defect</u>) <i>(mandatory by proposer):</i></p> <p>See also above. The original and other alternatives involve calculating costs of links and their alternative options. This is bespoke, detailed and complex, and, debatable over whether the solution costed is appropriate. This proposal avoids this.</p>	
<p>Impact on the CUSC <i>(this should be given where possible):</i></p> <p>The proposal will improve cost reflectivity when calculating generator local circuit charges associated with HVAC subsea cable connections or new HVDC connections. The CUSC will need amendment at 14.15.75 and 14.15.76.</p>	
<p>Impact on Core Industry Documentation <i>(this should be given where possible):</i></p> <p>This impacts the CUSC.</p>	

Impact on Computer Systems and Processes used by CUSC Parties *(this should be given where possible):*

Justification for the proposal with Reference to Applicable CUSC Objectives* *(mandatory by proposer):*

1. Competition. The proposal facilitates the relevant generators subject to the local circuit charges being able to compete more fairly in the market place.
2. Cost reflectivity. The proposal better reflects the costs incurred by the transmission parties (owners) that are relevant to the affected generators.
3. Transmission licensee business development. The proposal complements potential future changes to the transmission businesses by improving the charging basis for future HVAC and HVDC works, noting there is very little of either at present.
4. Compliance with regulations. Not affected.
5. Promoting efficiency in CUSC administration. If CMP303 changes are to be made to the CUSC, this proposal simplifies the way in which this change will be made and exercised in the future.

Attachments (Yes/No):
If Yes, Title and No. of pages of each Attachment:

Yes
Title - WACM 8 – Cost reduction pro-rata to import (reference BRN 1234/028/002C)
Pages - 9

Notes:

1. Applicable CUSC Objectives* - These are defined within the National Grid Electricity Transmission plc Licence under Standard Condition C10, paragraph 1. Reference should be made to this section when considering a proposed Modification.



Xero Energy Limited
60 Elliot Street
Glasgow G3 8DZ
United Kingdom
Tel: +44 (0)141 221 8556
www.xeroenergy.co.uk
Reg. SC313697 in Scotland

BRIEFING NOTE

PROJECT: CMP 303
SUBJECT: WACM 8 – Cost reduction pro-rata to import
CLIENT: Not applicable
REFERENCE: BRN 1234/028/002C
CLIENT REFERENCE: Not applicable

Document History

V	AUTH	VERF	APPR	DATE	NOTES
A	NCS	FW	NCS	27/11/2018	Draft version.
B	NCS	FW	NCS	05/12/2018	First draft for CMP 303 working group only.
C	NCS	FW	NCS	04/02/2019	Updated WACM references

Notes

This document and any accompanying documents are to be distributed to members within the named client organisation only and are not to be distributed to other third parties or the public without express written consent from Xero Energy Limited. Xero Energy Limited does not accept responsibility for the application or use made of information or advice supplied. Such responsibility remains with the client.

1 Introduction

1.1 General

This short note has been drafted by Dr Nigel Scott to constitute and explain a WACM to the CMP 303 process. This WACM is 8.

The original CMP 303 text identifies the CUSC defect as follows and identifies an example, highlighted in bold.

*When a new local circuit is built to enable the export of new generation, extra costs may be incurred on additional functionality that is unrelated to the needs of said generation. **For example, on an island requiring a DC connection, the transmission owner would naturally build the HVDC infrastructure as one-way, only allowing flow from the island, where the generation is located, to the mainland. There may be a cost difference if the link is built as bidirectional. The relevant TO may choose to incur any such incremental expenditure making the link bidirectional, if it felt that there were security benefits in terms of, under certain scenarios, securing demand.** ... Absent clarification of the exclusion of these extra costs, they are very likely to be included in the actual costs used to calculate the expansion factor and hence the relevant local circuit charge, meaning that relevant generators are facing a local circuit charge that is not fully cost-reflective.*

The proposed amended CUSC text is as follows.

14.15.75 AC sub-sea cable and HVDC circuit expansion factors are calculated on a case by case basis using actual project costs (Specific Circuit Expansion Factors), except that these project costs should only include costs relevant to and needed by the connected generators. The incremental cost of any extra functionality that the TO chooses to add, of wider benefit, should not be included.

14.15.76 Subject to 14.15.75, for HVDC circuit expansion factors both the cost of the converters and the cost of the cable are included in the calculation

This WACM 8 identifies an alternative method to quantify the necessary cost reduction to local circuit generator TNUoS charges as a result of the bidirectional nature of the local circuit, that bidirectional nature relating to import against the relevant generator's export for the purposes of demand and other. This is an alternative to the example in the original proposal.

1.2 Overview of WACM 8 proposal

For HVAC subsea cable connections or new HVDC connections that constitute a generator local circuit for the purposes of TNUoS charging, the proportion of the costs of the connection for import flows (e.g. for demand, and export on to other localities) must be recognised and should not be charged to the relevant generators. This is achieved by deducting (pro-rata) a proportion of the cost of the connection from the relevant cost entered to the generator local circuit TNUoS calculation. This pro-rata proportion shall be calculated using the import / generation export ratio.

1.3 Contents of this note

This note is set out as follows.

- Section 1 – Introduction (this section)
- Section 2 – Quantifying the costs
- Section 3 – Points of discussion
- Section 4 – Conclusions
- Section 5 – References
- Section 6 – Appendix A – Acronyms

2 Quantifying the costs

2.1 Introduction

This section examines the costs associated with the additional functionality, i.e. the import, and hence the costs that should be removed from the generator local circuit charges.

Three different calculation methods are proposed in this section based on:

- The known maximum import.
- The known maximum import plus an additional allowance for future import increases.
- Import capability instead of actual import.

2.2 Example using an HVDC link

Whilst the general method used could be applied to any case, it is easiest to understand the order of costs and the resultant generator local circuit charge reduction by way of an example. For the purposes of this note, an HVDC link is used. Costs used for this example are assumed and approximate and are based on proposals for Shetland [1, 2] and the Western Isles [3, 4].

The example considers a 600MW HVDC VSC link at a total cost of £700 million assumed to be broken down as follows.

- HVDC Converters £300 million
- HVDC cable circuit £300 million
- HVAC substation assets (switchgear, transformers, etc) £100 million

The overall HVDC converter and cable costs are entered into the local circuit TNUoS calculation as per the current CUSC methodology. This means that £600 million is entered into the local circuit TNUoS calculation giving a local circuit TNUoS charge to the generators of £76 per kW per annum.

It should be noted that non-asset specific costs such as development and consenting costs, insurance and project management are likely to be included in the above figures. These costs are normally allocated pro-rata over the HVDC and HVAC assets as per common practice.

2.3 Calculation methods

2.3.1 Known maximum import

To provide an example it is assumed the known maximum import to Shetland or the Western Isles constitutes 30MW peak for demand purposes. The ratio of import to export is thus 30/600 implying a 5% reduction in the relevant costs and generator local circuit TNUoS. In this case the generator local circuit TNUoS is reduced from £76 to £72 per kW per annum.

2.3.2 Known maximum import plus additional import allowance

Further to the above, it is proposed that a margin for factors such as load growth, demand fluctuations and other should be added. Careful consideration needs to be given to the most appropriate factor, and, for examples like the Western Isles which are interconnected to other parts of the transmission system, the potential through flows should also be accounted for. Other factors may also be relevant such as future interconnectors.

Taking the example of the Western Isles, there is a 24MVA interconnection back through the existing transmission system to Skye which could require a further 24MW of import. There should also be some allowance for growth in demand (which could allow for electric vehicles and socio-economic uplift among others). This figure should be determined by an agreed methodology and be reflective of common distribution and transmission practice together with case specific factors. For the purposes of this note, and to keep calculations simple, it is assumed this adds a further 6MW although this figure could easily be much larger. Overall, there is a known maximum import of 30MW, a potential additional 24MW import to Skye, and, a further 6MW allowance for demand growth giving 60MW total.

If 60MW is used, the ratio of import to export is thus 60/600 implying a 10% reduction in the relevant costs and generator local circuit TNUoS. In this case the generator local circuit TNUoS is reduced from £76 to £68 per kW per annum.

2.3.3 Import capability

Most local circuit assets will in theory be able to import as much as they export. The capability of the asset may be more than its actual use. Using capability would avoid the uncertainties and assumptions around import growth.

In the case of the Western Isles HVDC link, it is assumed that the link is fully bidirectional and hence has a 600MW import capability (to the Western Isles). If 600MW is used, the ratio of import to export is thus 600/600 implying a 100% reduction in the relevant costs and generator local circuit TNUoS. In this case the generator local circuit TNUoS is reduced from £76 to £0 per kW per annum.

3 Points of discussion

3.1 Peak imports

Peak import will be a relatively rare occurrence and it could be considered as to whether a peak figure is appropriate. Transmission assets are however sized to meet system peaks, notably in relation to demand. In addition, a similar issue arises for the generation export which itself may rarely reach its full (peak) rating.

3.2 Future imports

More difficult to assess is the treatment of over capacity for import increases in the future. A prudent network owner operator would normally size assets to allow for this uncertainty. In Section 2.3.2 several issues which merit consideration have been outlined and these include the following.

- Growth in demand - general
- System through flows, e.g. to other parts of the total system
- Imports for other matters such as interconnectors or energy storage
- Growth in demand due to fundamental shifts in electricity use such as electric vehicles

3.3 TNUoS tariffs over time

The generator local circuit TNUoS tariff will be set with the asset commissioning and then appropriately inflated over time. It will not normally be otherwise amended, irrespective of the amount of generation using the asset. However, if the import levels change over time it would be possible to adjust the tariffs accordingly. Alternately, the tariff should be set from the start with an appropriate allowance for change as outlined in this note.

3.4 Import capability

There is a case to be made that the pro-rata reduction in cost entered into the generator local circuit calculation should reflect capability. This would avoid issues of how to treat import variation over time. It also fully reflects the potential (import) utility of the asset.

3.5 Pro-rata calculation method

The method proposed appears reasonable and for the examples using assumed actual known maximum import and the same with an additional allowance results in cost and TNUoS reductions which are modest, e.g. 5% and 10% in the example used.

When this method is extended to the import capability, it will often result in a removal of the generator local circuit TNUoS in its entirety. It is therefore worth considering as to whether this is appropriate or whether the method should remove less. To some extent a 50% reduction would seem logical given the import and export capability is the same. However, demand currently pays around 85% of the total TNUoS levied and so the 100% reduction may be appropriate in this context.

4 Conclusions

4.1 General

This short note has outlined a relatively simple method, with three variations, to account for the extra costs of import on an HVAC subsea cable circuit or HVDC circuit when these circuits are local circuits for the purposes of charging generators. It is proposed to use a pro-rata method of import / export to assess how much cost should be deducted from the cost entered into the generator local circuit TNUoS calculation.

For the example used of the Western Isles, this results in a 5% reduction in the generator local circuit charge as the (assumed) known maximum import (demand) is 5% of the export capacity for generation.

It is proposed however that the percentage reduction should be increased to allow for other factors such as onward interconnection and future demand increase. For the example of the Western Isles this has given a 10% reduction in the generator local circuit charge.

Accounting for how the import might change in the future is however somewhat subjective. To overcome such difficulties and allow TNUoS tariffs to be clearly and unequivocally set from the outset, it is further proposed that the reduction for import could be based on capability rather than use. This is similar to the generator tariffs. For most local circuit assets, which can import as much as they export, this would result in a 100% reduction in costs entered into the generator local circuit TNUoS calculation, bringing the tariff to £0.

The first two methods, based on known maximum export and known maximum import with an additional allowance, result in modest reductions to cost and local circuit generator charge which appear cost reflective. Using capability however, while simpler, will tend to reduce the local circuit generator charge to zero.

It is proposed the calculations would be case (local circuit asset) specific.

5 References

- [1] Scottish and Southern Energy Power Distribution plc, "Shetland HVDC Link Consultation", August 2016.
- [2] P. Wheelhouse, "Renewables", in *Scottish Parliament*, Edinburgh, December 2016.
- [3] Scottish & Southern Electricity Network, "Western Isles HVDC Link Consultation", 2017.
- [4] Subsea World News, "Western Isles HVDC Link Costs Rise (UK)", 05 November 2012. [Online]. Available: www.subseaworldnews.com. [Accessed 05 November 2018].

6 Appendix A - Acronyms

Acronym	Definition
CMP	CUSC Modification Proposal
CUSC	Connection and Use of System Code
HVAC	High Voltage Alternating Current
HVDC	High Voltage Direct Current
kV	Kilovolt
MW	Megawatt
TO	Transmission Owner
VSC	Voltage Source Converter
WACM	Workgroup Alternative CUSC Modification proposal

CUSC WORKGROUP ALTERNATIVE REQUEST FORM

CUSC WORKGROUP ALTERNATIVE REQUEST FORM	
Respondent Name and contact details	<p><i>Dr Nigel Scott</i> Nigel.scott@xeroenergy.co.uk 0141 221 8556</p>
CMP303 Improving local circuit charge cost-reflectivity	
Capacity in which the WG Consultation Alternative Request is being raised : (i.e. CUSC Party, BSC Party or "National Consumer Council ")	Working group member
<p>Description of the Proposal for the Workgroup to consider <i>(mandatory by proposer):</i></p> <p>This WACM 9 is a combination of WACM 2 and WACM 8.</p> <p>WACM 2 - to remove the cost of the HVDC converters from the costs entered into the generator local circuit TNUoS calculation on the basis that the normal onshore methodology does not include substations.</p> <p>WACM 8 - to quantify the necessary cost reduction to local circuit generator TNUoS charges as a result of the bidirectional nature of the local circuit, that bidirectional nature relating to import against the relevant generator's export for the purposes of demand and other.</p>	
<p>Description of the difference(s) between your proposal compared to Original / Workgroup Alternative(s) <i>(mandatory by proposer):</i></p> <p>Same as those of WACM 2 and 8.</p>	
<p>Justification for the proposal (<u>including why the Original proposal / Workgroup Alternative(s) does not address the defect</u>) <i>(mandatory by proposer):</i></p> <p>Same as those of WACM 2 and 8.</p>	
<p>Impact on the CUSC <i>(this should be given where possible):</i></p> <p>Same as those of WACM 2 and 8.</p>	
<p>Impact on Core Industry Documentation <i>(this should be given where possible):</i></p> <p>Same as those of WACM 2 and 8.</p>	
<p>Impact on Computer Systems and Processes used by CUSC Parties <i>(this should be given where possible):</i></p>	

Justification for the proposal with Reference to Applicable CUSC Objectives* (*mandatory by proposer*):

Same as those of WACM 2 and 8.

Attachments (Yes/No):
If Yes, Title and No. of pages of each Attachment:

Yes
Title - WACM 3 - Wider system benefits of HVDC (reference BRN 1234/028/001C)
Pages – 18
Title - WACM 8 – Cost reduction pro-rata to import (reference BRN 1234/028/002C)
Pages - 9

Notes:

1. Applicable CUSC Objectives* - These are defined within the National Grid Electricity Transmission plc Licence under Standard Condition C10, paragraph 1. Reference should be made to this section when considering a proposed Modification.

CMP303 – ORIGINAL

Onshore Wider Circuit Expansion Factors

- 14.15.70 Base onshore expansion factors are calculated by deriving individual expansion constants for the various types of circuit, following the same principles used to calculate the 400kV overhead line expansion constant. The factors are then derived by dividing the calculated expansion constant by the 400kV overhead line expansion constant. The factors will be fixed for each respective price control period.
- 14.15.71 In calculating the onshore underground cable factors, the forecast costs are weighted equally between urban and rural installation, and direct burial has been assumed. The operating costs for cable are aligned with those for overhead line. An allowance for overhead costs has also been included in the calculations.
- 14.15.72 The 132kV onshore circuit expansion factor is applied on a TO basis. This is to reflect the regional variation of plans to rebuild circuits at a lower voltage capacity to 400kV. The 132kV cable and line factor is calculated on the proportion of 132kV circuits likely to be uprated to 400kV. The 132kV expansion factor is then calculated by weighting the 132kV cable and overhead line costs with the relevant 400kV expansion factor, based on the proportion of 132kV circuitry to be uprated to 400kV. For example, in the TO areas of National Grid and Scottish Power where there are no plans to uprate any 132kV circuits, the full cable and overhead line costs of 132kV circuit are reflected in the 132kV expansion factor calculation.
- 14.15.73 The 275kV onshore circuit expansion factor is applied on a GB basis and includes a weighting of 83% of the relevant 400kV cable and overhead line factor. This is to reflect the averaged proportion of circuits across all three Transmission Licensees which are likely to be uprated from 275kV to 400kV across GB within a price control period.
- 14.15.74 The 400kV onshore circuit expansion factor is applied on a GB basis and reflects the full costs for 400kV cable and overhead lines.
- 14.15.75 AC sub-sea cable and HVDC circuit expansion factors are calculated on a case by case basis using actual project costs (Specific Circuit Expansion Factors)- Where the relevant Transmission Licensee has chosen, through its own assessment, to provide functionality above and beyond that which is needed by the relevant Generator User, (and that Transmission Licensee has provided to The Company the incremental cost of such functionality), The Company shall exclude that incremental cost from the actual project costs, for the purposes of calculating the Specific Circuit Expansion Factor. Where the Transmission Licensee has, following its own best endeavours been unable to provide the incremental cost of the functionality, The Company shall use the actual project costs provided to it by the relevant Transmission Licensee and no adjustment shall be made in relation to any additional functionality, except that these project costs should only include costs relevant to and needed by the connected generators. The incremental cost of any extra functionality that the TO chooses to add, of wider benefit, should not be included.

14.15.76 [Subject to 14.15.75](#), calculation of HVDC circuit expansion factors and AC sub-sea circuit expansion factors, shall include only the cost of the converters (where applicable); the cost of the cable; and a percentage of the total overhead project costs, defined as the combined costs of the cables and converters (as relevant) divided by the total capital cost of the project.

CMP303 – WACM1 – 50% Converter

Onshore Wider Circuit Expansion Factors

14.15.70 Base onshore expansion factors are calculated by deriving individual expansion constants for the various types of circuit, following the same principles used to calculate the 400kV overhead line expansion constant. The factors are then derived by dividing the calculated expansion constant by the 400kV overhead line expansion constant. The factors will be fixed for each respective price control period.

14.15.71 In calculating the onshore underground cable factors, the forecast costs are weighted equally between urban and rural installation, and direct burial has been assumed. The operating costs for cable are aligned with those for overhead line. An allowance for overhead costs has also been included in the calculations.

14.15.72 The 132kV onshore circuit expansion factor is applied on a TO basis. This is to reflect the regional variation of plans to rebuild circuits at a lower voltage capacity to 400kV. The 132kV cable and line factor is calculated on the proportion of 132kV circuits likely to be uprated to 400kV. The 132kV expansion factor is then calculated by weighting the 132kV cable and overhead line costs with the relevant 400kV expansion factor, based on the proportion of 132kV circuitry to be uprated to 400kV. For example, in the TO areas of National Grid and Scottish Power where there are no plans to uprate any 132kV circuits, the full cable and overhead line costs of 132kV circuit are reflected in the 132kV expansion factor calculation.

14.15.73 The 275kV onshore circuit expansion factor is applied on a GB basis and includes a weighting of 83% of the relevant 400kV cable and overhead line factor. This is to reflect the averaged proportion of circuits across all three Transmission Licensees which are likely to be uprated from 275kV to 400kV across GB within a price control period.

14.15.74 The 400kV onshore circuit expansion factor is applied on a GB basis and reflects the full costs for 400kV cable and overhead lines.

14.15.75 AC sub-sea cable and HVDC circuit expansion factors are calculated on a case by case basis using actual project costs (Specific Circuit Expansion Factors). Where the relevant Transmission Licensee has chosen, through its own assessment, to provide functionality above and beyond that which is needed by the relevant Generator User, and that Transmission Licensee has provided to The Company the incremental cost of such functionality, The Company shall exclude that incremental cost from the actual project costs, for the purposes of calculating the Specific Circuit Expansion Factor. Where the Transmission Licensee has, following its own best endeavours been unable to provide the incremental cost of the functionality, The Company shall use the actual project costs provided to it by the relevant Transmission Licensee and no adjustment shall be made in relation to any additional functionality.

14.15.76 Subject to 14.15.75, calculation of HVDC circuit expansion factors, and AC sub-sea circuit expansion factors shall include only ~~both 50% of~~ the cost of the converter(s) (where applicable), the full cost of the cable; and a percentage of the total overhead project costs, defined as the combined costs of the cables and converters (as relevant) divided by the total capital cost of the project.

CMP303 – WACM2 – 100% Converter

Onshore Wider Circuit Expansion Factors

14.15.70 Base onshore expansion factors are calculated by deriving individual expansion constants for the various types of circuit, following the same principles used to calculate the 400kV overhead line expansion constant. The factors are then derived by dividing the calculated expansion constant by the 400kV overhead line expansion constant. The factors will be fixed for each respective price control period.

14.15.71 In calculating the onshore underground cable factors, the forecast costs are weighted equally between urban and rural installation, and direct burial has been assumed. The operating costs for cable are aligned with those for overhead line. An allowance for overhead costs has also been included in the calculations.

14.15.72 The 132kV onshore circuit expansion factor is applied on a TO basis. This is to reflect the regional variation of plans to rebuild circuits at a lower voltage capacity to 400kV. The 132kV cable and line factor is calculated on the proportion of 132kV circuits likely to be uprated to 400kV. The 132kV expansion factor is then calculated by weighting the 132kV cable and overhead line costs with the relevant 400kV expansion factor, based on the proportion of 132kV circuitry to be uprated to 400kV. For example, in the TO areas of National Grid and Scottish Power where there are no plans to uprate any 132kV circuits, the full cable and overhead line costs of 132kV circuit are reflected in the 132kV expansion factor calculation.

14.15.73 The 275kV onshore circuit expansion factor is applied on a GB basis and includes a weighting of 83% of the relevant 400kV cable and overhead line factor. This is to reflect the averaged proportion of circuits across all three Transmission Licensees which are likely to be uprated from 275kV to 400kV across GB within a price control period.

14.15.74 The 400kV onshore circuit expansion factor is applied on a GB basis and reflects the full costs for 400kV cable and overhead lines.

14.15.75 AC sub-sea cable and HVDC circuit expansion factors are calculated on a case by case basis using actual project costs (Specific Circuit Expansion Factors). Where the relevant Transmission Licensee has chosen, through its own assessment, to provide functionality above and beyond that which is needed by the relevant Generator User, (and that Transmission Licensee has provided to The Company the incremental cost of such functionality), The Company shall exclude that incremental cost from the actual project costs, for the purposes of calculating the Specific Circuit Expansion Factor. Where the Transmission Licensee has, following its own best endeavours been unable to provide the incremental cost of the functionality, The Company shall use the actual project costs provided to it by the relevant Transmission Licensee and no adjustment shall be made in relation to any additional functionality

14.15.76 Subject to 14.15.75, calculation of HVDC circuit expansion factors and AC sub-sea circuit expansion factors shall include ~~both the cost of the converters and only~~ the cost of the cable ~~are~~ and a percentage of the total overhead project costs, defined as the combined costs of the cables and converters (as relevant) divided by the total capital cost of the project. For the avoidance of doubt, the cost of the convertor(s) is not included in the calculation.

CMP303 – WACM3 – Case by Case Converter

Onshore Wider Circuit Expansion Factors

14.15.70 Base onshore expansion factors are calculated by deriving individual expansion constants for the various types of circuit, following the same principles used to calculate the 400kV overhead line expansion constant. The factors are then derived by dividing the calculated expansion constant by the 400kV overhead line expansion constant. The factors will be fixed for each respective price control period.

14.15.71 In calculating the onshore underground cable factors, the forecast costs are weighted equally between urban and rural installation, and direct burial has been assumed. The operating costs for cable are aligned with those for overhead line. An allowance for overhead costs has also been included in the calculations.

14.15.72 The 132kV onshore circuit expansion factor is applied on a TO basis. This is to reflect the regional variation of plans to rebuild circuits at a lower voltage capacity to 400kV. The 132kV cable and line factor is calculated on the proportion of 132kV circuits likely to be uprated to 400kV. The 132kV expansion factor is then calculated by weighting the 132kV cable and overhead line costs with the relevant 400kV expansion factor, based on the proportion of 132kV circuitry to be uprated to 400kV. For example, in the TO areas of National Grid and Scottish Power where there are no plans to uprate any 132kV circuits, the full cable and overhead line costs of 132kV circuit are reflected in the 132kV expansion factor calculation.

14.15.73 The 275kV onshore circuit expansion factor is applied on a GB basis and includes a weighting of 83% of the relevant 400kV cable and overhead line factor. This is to reflect the averaged proportion of circuits across all three Transmission Licensees which are likely to be uprated from 275kV to 400kV across GB within a price control period.

14.15.74 The 400kV onshore circuit expansion factor is applied on a GB basis and reflects the full costs for 400kV cable and overhead lines.

14.15.75 AC sub-sea cable and HVDC circuit expansion factors are calculated on a case by case basis using actual project costs (Specific Circuit Expansion Factors). Where the relevant Transmission Licensee has chosen, through its own assessment, to provide functionality above and beyond that which is needed by the relevant Generator User, (and that Transmission Licensee has provided to The Company the incremental cost of such functionality), The Company shall exclude that incremental cost from the actual project costs, for

the purposes of calculating the Specific Circuit Expansion Factor. Where the Transmission Licensee has, following its own best endeavours been unable to provide the incremental cost of the functionality, The Company shall use the actual project costs provided to it by the relevant Transmission Licensee and no adjustment shall be made in relation to any additional functionality.

14.15.76 Subject to 14.15.75 above, calculation of HVDC circuit expansion factors, and AC sub-sea circuit expansion factors shall include only the cost of the converters (where applicable), the cost of the cable and a percentage of the total overhead project costs, defined as the combined costs of the cables and converters (as relevant) divided by the total capital cost of the project. From this cost should be debited the cost of the following equivalent plant were it to replace the HVDC link, such cost to be provided by the relevant Transmission Licensee to The Company.

– A reactive power and voltage control device at each end of the HVDC link with the capability of the HVDC converters to the extent that capability may be used.

– A quadrature booster with the capability of the HVDC link where the link is run in parallel with other Transmission Circuits or the Distribution System.

An additional cost is also to be debited to represent the Black Start capability of the HVDC link. This cost is to be a percentage of the aggregated cost for procuring Black Start as published by The Company. The percentage of this cost to be taken from the actual project costs is calculated by dividing the peak Demand the HVDC link can Black Start by the total Chargeable Gross Demand Capacity in GB. Where no suitable data is to calculate this percentage, determined by The Company, is provided to The Company no adjustment shall be made.

The maximum Demand that the HVDC link can Black Start shall be the rating of the HVDC link where it connects two areas of mainland, or where it connects mainland to island shall be the lower of:

(a) the rating of the HVDC link

(b) maximum gross Demand on the island.

CMP303 – WACM4 – DUoS offset + Original

Onshore Wider Circuit Expansion Factors

14.15.70 Base onshore expansion factors are calculated by deriving individual expansion constants for the various types of circuit, following the same principles used to calculate the 400kV overhead line expansion constant. The

factors are then derived by dividing the calculated expansion constant by the 400kV overhead line expansion constant. The factors will be fixed for each respective price control period.

- 14.15.71 In calculating the onshore underground cable factors, the forecast costs are weighted equally between urban and rural installation, and direct burial has been assumed. The operating costs for cable are aligned with those for overhead line. An allowance for overhead costs has also been included in the calculations.
- 14.15.72 The 132kV onshore circuit expansion factor is applied on a TO basis. This is to reflect the regional variation of plans to rebuild circuits at a lower voltage capacity to 400kV. The 132kV cable and line factor is calculated on the proportion of 132kV circuits likely to be uprated to 400kV. The 132kV expansion factor is then calculated by weighting the 132kV cable and overhead line costs with the relevant 400kV expansion factor, based on the proportion of 132kV circuitry to be uprated to 400kV. For example, in the TO areas of National Grid and Scottish Power where there are no plans to uprate any 132kV circuits, the full cable and overhead line costs of 132kV circuit are reflected in the 132kV expansion factor calculation.
- 14.15.73 The 275kV onshore circuit expansion factor is applied on a GB basis and includes a weighting of 83% of the relevant 400kV cable and overhead line factor. This is to reflect the averaged proportion of circuits across all three Transmission Licensees which are likely to be uprated from 275kV to 400kV across GB within a price control period.
- 14.15.74 The 400kV onshore circuit expansion factor is applied on a GB basis and reflects the full costs for 400kV cable and overhead lines.
- 14.15.75 AC sub-sea cable and HVDC circuit expansion factors are calculated on a case by case basis using actual project costs (Specific Circuit Expansion Factors). Where the relevant Transmission Licensee has chosen, through his own assessment, to provide functionality above and beyond that which is needed by the relevant Generator User, (and that Transmission Licensee has provided to The Company the incremental cost of such functionality), The Company shall exclude that incremental cost from the actual project costs, for the purposes of calculating the Specific Circuit Expansion Factor. Where the Transmission Licensee has, following its own best endeavours been unable to provide the incremental cost of the functionality, The Company shall use the actual project costs provided to it by the relevant Transmission Licensee and no adjustment shall be made in relation to any additional functionality
- 14.15.76 In the event that The Authority decides to allow a Distribution Network Owner User and a Transmission Owner to net, or partially-net any revenues between them, such that Use of System charges for the Transmission Network, and use of system charges for the Distribution Network are offset, and The Company is advised by The Authority or Transmission Owner of a commensurate reduction in the costs or a change in the components that would otherwise be considered in the calculation of the expansion factor, The Company shall calculate the expansion factor using the revised information provided to it by the relevant party.

14.15.77 [Subject to 14.15.75](#), calculation of HVDC circuit expansion factors and AC sub-sea circuit expansion factors shall include only the cost of the converters (where applicable), the cost of the cable and a percentage of the total overhead project costs, defined as the combined costs of the cables and converters (as relevant) divided by the total capital cost of the project

CMP303 – WACM5 – 50% converter + DUoS offset + original

Onshore Wider Circuit Expansion Factors

- 14.15.70 Base onshore expansion factors are calculated by deriving individual expansion constants for the various types of circuit, following the same principles used to calculate the 400kV overhead line expansion constant. The factors are then derived by dividing the calculated expansion constant by the 400kV overhead line expansion constant. The factors will be fixed for each respective price control period.
- 14.15.71 In calculating the onshore underground cable factors, the forecast costs are weighted equally between urban and rural installation, and direct burial has been assumed. The operating costs for cable are aligned with those for overhead line. An allowance for overhead costs has also been included in the calculations.
- 14.15.72 The 132kV onshore circuit expansion factor is applied on a TO basis. This is to reflect the regional variation of plans to rebuild circuits at a lower voltage capacity to 400kV. The 132kV cable and line factor is calculated on the proportion of 132kV circuits likely to be uprated to 400kV. The 132kV expansion factor is then calculated by weighting the 132kV cable and overhead line costs with the relevant 400kV expansion factor, based on the proportion of 132kV circuitry to be uprated to 400kV. For example, in the TO areas of National Grid and Scottish Power where there are no plans to uprate any 132kV circuits, the full cable and overhead line costs of 132kV circuit are reflected in the 132kV expansion factor calculation.
- 14.15.73 The 275kV onshore circuit expansion factor is applied on a GB basis and includes a weighting of 83% of the relevant 400kV cable and overhead line factor. This is to reflect the averaged proportion of circuits across all three Transmission Licensees which are likely to be uprated from 275kV to 400kV across GB within a price control period.
- 14.15.74 The 400kV onshore circuit expansion factor is applied on a GB basis and reflects the full costs for 400kV cable and overhead lines.
- 14.15.75 AC sub-sea cable and HVDC circuit expansion factors are calculated on a case by case basis using actual project costs (Specific Circuit Expansion Factors). Where the relevant Transmission Licensee has chosen, through its own assessment, to provide functionality above and beyond that which is needed by the relevant Generator User, (and that Transmission Licensee has provided to The Company the incremental cost of such functionality), The Company shall exclude that incremental cost from the actual project costs, for the purposes of calculating the Specific Circuit Expansion Factor. Where the Transmission Licensee has, following its own best endeavours been unable to provide the incremental cost of the functionality, The Company shall use the actual project costs provided to it by the relevant Transmission Licensee and no adjustment shall be made in relation to any additional functionality
- 14.15.76 In the event that The Authority decides to allow a Distribution Network Owner User and a Transmission Owner to net, or partially-net any revenues between them, such that Use of System charges for the Transmission Network, and use of system charges for the Distribution Network are offset, and The Company is advised by The Authority or Transmission Owner of a commensurate reduction in the costs or a change in the components that would otherwise be considered in the calculation of the expansion factor, The

Company shall calculate the expansion factor using the revised information provided to it by the relevant party.

- 14.15.77 Subject to 14.15.75, calculation of HVDC circuit expansion factors and AC sub-sea circuit expansion factors shall include only ~~both 50% of~~ the cost of the converter(s) (where applicable), and the full cost of the cable and a percentage of the total overhead project costs, defined as the combined costs of the cables and converters (as relevant) divided by the total capital cost of the project.

Onshore Wider Circuit Expansion Factors

- 14.15.70 Base onshore expansion factors are calculated by deriving individual expansion constants for the various types of circuit, following the same principles used to calculate the 400kV overhead line expansion constant. The factors are then derived by dividing the calculated expansion constant by the 400kV overhead line expansion constant. The factors will be fixed for each respective price control period.
- 14.15.71 In calculating the onshore underground cable factors, the forecast costs are weighted equally between urban and rural installation, and direct burial has been assumed. The operating costs for cable are aligned with those for overhead line. An allowance for overhead costs has also been included in the calculations.
- 14.15.72 The 132kV onshore circuit expansion factor is applied on a TO basis. This is to reflect the regional variation of plans to rebuild circuits at a lower voltage capacity to 400kV. The 132kV cable and line factor is calculated on the proportion of 132kV circuits likely to be uprated to 400kV. The 132kV expansion factor is then calculated by weighting the 132kV cable and overhead line costs with the relevant 400kV expansion factor, based on the proportion of 132kV circuitry to be uprated to 400kV. For example, in the TO areas of National Grid and Scottish Power where there are no plans to uprate any 132kV circuits, the full cable and overhead line costs of 132kV circuit are reflected in the 132kV expansion factor calculation.
- 14.15.73 The 275kV onshore circuit expansion factor is applied on a GB basis and includes a weighting of 83% of the relevant 400kV cable and overhead line factor. This is to reflect the averaged proportion of circuits across all three Transmission Licensees which are likely to be uprated from 275kV to 400kV across GB within a price control period.
- 14.15.74 The 400kV onshore circuit expansion factor is applied on a GB basis and reflects the full costs for 400kV cable and overhead lines.
- 14.15.75 AC sub-sea cable and HVDC circuit expansion factors are calculated on a case by case basis using actual project costs (Specific Circuit Expansion Factors). Where the relevant Transmission Licensee has chosen, through its own assessment, to provide functionality above and beyond that which is needed by the relevant Generator User, (and that Transmission Licensee has provided to The Company the incremental cost of such functionality), The Company shall exclude that incremental cost from the actual project costs, for the purposes of calculating the Specific Circuit Expansion Factor. Where the Transmission Licensee has, following its own best endeavours been unable to provide the incremental cost of the functionality, The Company shall use the actual project costs provided to it by the relevant Transmission Licensee and no adjustment shall be made in relation to any additional functionality
- 14.15.76 In the event that The Authority decides to allow a Distribution Network Owner User and a Transmission Owner to net, or partially-net any revenues between them, such that Use of System charges for the Transmission Network, and use of system charges for the Distribution Network are offset, and The Company is advised by The Authority or Transmission Owner of a commensurate reduction in the costs or a change in the components that

would otherwise be considered in the calculation of the expansion factor, The Company shall calculate the expansion factor using the revised information provided to it by the relevant party.

14.15.77 Subject to 14.15.75, calculation of HVDC circuit expansion factors and AC sub-sea circuit expansion factors shall include ~~both the cost of the converters and only~~ the cost of the cable ~~are~~ and a percentage of the total overhead project costs, defined as the combined costs of the cables and converters (as relevant) divided by the total capital cost of the project. For the avoidance of doubt, the cost of the convertor(s) is not included in the calculation.

CMP303 – WACM7 – Case by case converter + DUoS offset + Original

Onshore Wider Circuit Expansion Factors

14.15.70 Base onshore expansion factors are calculated by deriving individual expansion constants for the various types of circuit, following the same principles used to calculate the 400kV overhead line expansion constant. The factors are then derived by dividing the calculated expansion constant by the 400kV overhead line expansion constant. The factors will be fixed for each respective price control period.

14.15.71 In calculating the onshore underground cable factors, the forecast costs are weighted equally between urban and rural installation, and direct burial has been assumed. The operating costs for cable are aligned with those for overhead line. An allowance for overhead costs has also been included in the calculations.

14.15.72 The 132kV onshore circuit expansion factor is applied on a TO basis. This is to reflect the regional variation of plans to rebuild circuits at a lower voltage capacity to 400kV. The 132kV cable and line factor is calculated on the proportion of 132kV circuits likely to be uprated to 400kV. The 132kV expansion factor is then calculated by weighting the 132kV cable and overhead line costs with the relevant 400kV expansion factor, based on the proportion of 132kV circuitry to be uprated to 400kV. For example, in the TO areas of National Grid and Scottish Power where there are no plans to uprate any 132kV circuits, the full cable and overhead line costs of 132kV circuit are reflected in the 132kV expansion factor calculation.

14.15.73 The 275kV onshore circuit expansion factor is applied on a GB basis and includes a weighting of 83% of the relevant 400kV cable and overhead line factor. This is to reflect the averaged proportion of circuits across all three Transmission Licensees which are likely to be uprated from 275kV to 400kV across GB within a price control period.

14.15.74 The 400kV onshore circuit expansion factor is applied on a GB basis and reflects the full costs for 400kV cable and overhead lines.

14.15.75 AC sub-sea cable and HVDC circuit expansion factors are calculated on a case by case basis using actual project costs (Specific Circuit Expansion Factors). Where the Relevant Transmission Licensee has chosen, through its own assessment, to provide functionality above and beyond that which is needed by the relevant Generator User, (and that Transmission Licensee has provided to The Company the incremental cost of such functionality), The Company shall exclude that incremental cost from the actual project costs, for the purposes of calculating the Specific Circuit Expansion Factor. Where the Transmission Licensee has, following its own best endeavours, not provided the incremental cost of the functionality, The Company shall use the actual project costs provided to it by the relevant Transmission Licensee and no adjustment shall be made in relation to any additional functionality

14.15.76 In the event that The Authority decides to allow a Distribution Network Owner User and a Transmission Owner to net, or partially-net any revenues

between them, such that Use of System charges for the Transmission Network, and use of system charges for the Distribution Network are offset, and The Company is advised by The Authority or Transmission Owner of a commensurate reduction in the costs or a change in the components that would otherwise be considered in the calculation of the expansion factor, The Company shall calculate the expansion factor using the revised information provided to it by the relevant party.

14.15.77 Subject to 14.15.75 above, calculation of HVDC circuit expansion factors and AC sub-sea circuit expansion factors shall include only the cost of the converters (where applicable) and the cost of the cable and a percentage of the total overhead project costs, defined as the combined costs of the cables and converters (as relevant) divided by the total capital cost of the project. From this cost should be debited the cost of the following equivalent plant were it to replace the HVDC link, such cost to be provided by the relevant Transmission Licensee to The Company.

– A reactive power and voltage control device at each end of the HVDC link with the capability of the HVDC converters to the extent that capability may be used.

– A quadrature booster with the capability of the HVDC link where the link is run in parallel with other Transmission Circuits or the Distribution System.

An additional cost is also to be debited to represent the Black Start capability of the HVDC link. This cost is to be a percentage of the aggregated cost for procuring Black Start as published by The Company. The percentage of this cost to be taken from the actual project costs is calculated by dividing the peak Demand the HVDC link can Black Start by the total Chargeable Gross Demand Capacity in GB. Where no suitable data is to calculate this percentage, determined by The Company, is provided to The Company no adjustment shall be made.

The maximum Demand that the HVDC link can Black Start shall be the rating of the HVDC link where it connects two areas of mainland, or where it connects mainland to island shall be the lower of;

(a) the rating of the HVDC link

(b) maximum gross Demand on the island.

CMP303 – WACM8 – Pro-rata (excludes original)

Onshore Wider Circuit Expansion Factors

14.15.70 Base onshore expansion factors are calculated by deriving individual expansion constants for the various types of circuit, following the same principles used to calculate the 400kV overhead line expansion constant. The factors are then derived by dividing the calculated expansion constant by the 400kV overhead line expansion constant. The factors will be fixed for each respective price control period.

14.15.71 In calculating the onshore underground cable factors, the forecast costs are weighted equally between urban and rural installation, and direct burial has been assumed. The operating costs for cable are aligned with those for overhead line. An allowance for overhead costs has also been included in the calculations.

14.15.72 The 132kV onshore circuit expansion factor is applied on a TO basis. This is to reflect the regional variation of plans to rebuild circuits at a lower voltage capacity to 400kV. The 132kV cable and line factor is calculated on the proportion of 132kV circuits likely to be uprated to 400kV. The 132kV expansion factor is then calculated by weighting the 132kV cable and overhead line costs with the relevant 400kV expansion factor, based on the proportion of 132kV circuitry to be uprated to 400kV. For example, in the TO areas of National Grid and Scottish Power where there are no plans to uprate any 132kV circuits, the full cable and overhead line costs of 132kV circuit are reflected in the 132kV expansion factor calculation.

14.15.73 The 275kV onshore circuit expansion factor is applied on a GB basis and includes a weighting of 83% of the relevant 400kV cable and overhead line factor. This is to reflect the averaged proportion of circuits across all three Transmission Licensees which are likely to be uprated from 275kV to 400kV across GB within a price control period.

14.15.74 The 400kV onshore circuit expansion factor is applied on a GB basis and reflects the full costs for 400kV cable and overhead lines.

14.15.75 AC sub-sea cable and HVDC circuit expansion factors are calculated on a case by case basis using actual project costs (Specific Circuit Expansion Factors). A deduction shall be made from the costs to reflect the use of the AC sub-sea cable and HVDC circuit expansion factors for import. This deduction shall be made using the potential import requirement to export rating. The import requirement shall be determined by the peak demand over the AC sub-sea cable by The Company using data from the Distribution licensee or Transmission licensee. The import requirement shall be determined by the sum of two parts as follows:

(a) The distribution system peak demand on the island as required by the relevant Distribution Licensee and provided by the relevant Distribution Licensee to The Company.

(b) The transmission system peak demand on the island (excluding the demand included under a)) and provided by the relevant Transmission Licensee to The Company.

Where no suitable data, determined by The Company, is provided to The Company no adjustment shall be made.

For the avoidance of doubt an example is enclosed below:

A transmission voltage sub-sea AC cable of export capability of 100MW with actual project costs of £175million is built to connect a generation user on an island. The Distribution licensee provides to The Company a peak demand of 10MW on the island in question. There is no transmission connected demand on the island as confirmed by the Transmission Licensee. The deduction from actual project costs is 10/100 or 10%, so the actual project costs to be fed into the local circuit tariff calculation is £157.5million.

~~14.15.75~~14.15.76 Calculation of HVDC circuit expansion factors and AC sub-sea circuit expansion factors shall include only the cost of the converters (where applicable), the cost of the cable and a percentage of the total overhead project costs, defined as the combined costs of the cables and converters (as relevant) divided by the total capital cost of the project.

CMP303 – WACM9 – 100% Converter + Pro-rated (excludes original)

Onshore Wider Circuit Expansion Factors

14.15.70 Base onshore expansion factors are calculated by deriving individual expansion constants for the various types of circuit, following the same principles used to calculate the 400kV overhead line expansion constant. The factors are then derived by dividing the calculated expansion constant by the 400kV overhead line expansion constant. The factors will be fixed for each respective price control period.

14.15.71 In calculating the onshore underground cable factors, the forecast costs are weighted equally between urban and rural installation, and direct burial has been assumed. The operating costs for cable are aligned with those for overhead line. An allowance for overhead costs has also been included in the calculations.

14.15.72 The 132kV onshore circuit expansion factor is applied on a TO basis. This is to reflect the regional variation of plans to rebuild circuits at a lower voltage capacity to 400kV. The 132kV cable and line factor is calculated on the proportion of 132kV circuits likely to be uprated to 400kV. The 132kV expansion factor is then calculated by weighting the 132kV cable and overhead line costs with the relevant 400kV expansion factor, based on the proportion of 132kV circuitry to be uprated to 400kV. For example, in the TO areas of National Grid and Scottish Power where there are no plans to uprate

any 132kV circuits, the full cable and overhead line costs of 132kV circuit are reflected in the 132kV expansion factor calculation.

14.15.73 The 275kV onshore circuit expansion factor is applied on a GB basis and includes a weighting of 83% of the relevant 400kV cable and overhead line factor. This is to reflect the averaged proportion of circuits across all three Transmission Licensees which are likely to be updated from 275kV to 400kV across GB within a price control period.

14.15.74 The 400kV onshore circuit expansion factor is applied on a GB basis and reflects the full costs for 400kV cable and overhead lines.

14.14.75 AC sub-sea cable and HVDC circuit expansion factors are calculated on a case by case basis using actual project costs (Specific Circuit Expansion Factors). A deduction shall be made from the costs to reflect the use of the AC sub-sea cable and HVDC circuit expansion factors for import. This deduction shall be made using the potential import requirement to export rating. The import requirement shall be determined by the peak demand over the AC sub-sea cable by The Company using data from the Distribution licensee or Transmission licensee. The import requirement shall be determined by the sum of two parts as follows:

- (a) The distribution system peak demand on the island as required by the relevant Distribution Licensee and provided by the relevant Distribution Licensee to The Company.
- (b) The transmission system peak demand on the island (excluding the demand included under a)) and provided by the relevant Transmission Licensee to The Company.

Where no suitable data, determined by The Company, is provided to The Company no adjustment shall be made.

For the avoidance of doubt an example is enclosed below:

A transmission voltage sub-sea AC cable of export capability of 100MW with actual project costs of £175million is built to connect a generation user on an island. The Distribution licensee provides to The Company a peak demand of 10MW on the island in question. There is no transmission connected demand on the island as confirmed by the Transmission Licensee. The deduction from actual project costs is 10/100 or 10%, so the actual project costs to be fed into the local circuit tariff calculation is £157.5million.

14.15.76 Subject to 14.15.75, calculation of HVDC circuit expansion factors and AC sub-sea circuit expansion factors shall include only the cost of the cable and a percentage of the total overhead project costs, defined as the combined costs of the cables and converters (as relevant) divided by the total capital cost of the project. For the avoidance of doubt, the cost of the convertor(s) is not included in the calculation.

21 Annex 8: First Code Administrator Consultation Responses

CMP303 - Improving local circuit charge cost-reflectivity

Industry parties are invited to respond to this consultation expressing their views and supplying the rationale for those views, particularly in respect of any specific questions detailed below.

Please send your responses by **19 March 2019** to cusc.team@nationalgrid.com. Please note that any responses received after the deadline or sent to a different email address may not receive due consideration by the CUSC Modifications Panel when it makes its final determination.

These responses will be included in the Final CUSC Modification Report which is submitted to the CUSC Modifications Panel.

Respondent:	Simon Swiatek sswiatek@forsaenergy.com
Company Name:	Forsa Energy
Do you believe that the proposed original or any of the alternatives better facilitate the Applicable CUSC Objectives? Please include your reasoning.	<p>[with the exception of WACMs 4, 5, 6 and 7]:</p> <p>(a) Yes - the removal of additional costs that are unrelated to the generator's needs will assist generators in market competition.</p> <p>(b) Yes – the proposal means the local circuit charge payable by the generator will be reflective of the costs incurred by the relevant transmission licensee in providing the required export capability (removing any extra costs unrelated to the required export capability).</p> <p>(c) Yes - this proposal will take account of developments in transmission licensees' business such as providing HVDC links to remote island. The proposal will mean that costs unrelated to export capability are not assigned to generator local circuit tariffs.</p> <p>We are supportive of the original and WACMs 1 2, 3, 8 and 9 as shown in our voting statement. These WACMs provide various degrees of assistance in meeting the CUSC objectives. We note in particular that the proposal to remove converter costs (as seen in WACMs 1, 2, 3 and 9) reflects some of the ideas developed previously as part of CMP213. WACM 8 offers a straightforward methodology for reflecting the level of demand import. WACM 9 takes account of the additional benefits provided by converters (by combining WACM 3 and WACM 8).</p>
Do you support the proposed implementation approach? If not, please state why and provide an alternative suggestion where possible.	Yes. We agree with section 7 of the consultation that the modification would require an authority decision at least a few weeks in advance of the proposed CFD auction. This is required in order to allow generators to review their financial modelling and finalise their auction bids.

Do you have any other comments?	As per our voting statement, at this time we are not convinced that WACM 4 (and associated WACMs 5, 6 and 7) will be non-discriminatory to all islands, though we do note the ongoing work being carried out by the proposer.

CUSC Code Administrator Consultation Response Proforma

CMP303 - Improving local circuit charge cost-reflectivity

Industry parties are invited to respond to this consultation expressing their views and supplying the rationale for those views, particularly in respect of any specific questions detailed below.

Please send your responses by **19 March 2019** to cusc.team@nationalgrid.com. Please note that any responses received after the deadline or sent to a different email address may not receive due consideration by the CUSC Modifications Panel when it makes its final determination.

These responses will be included in the Final CUSC Modification Report which is submitted to the CUSC Modifications Panel.

Respondent:	<i>Daniel Badcock, dbadcock@peellandp.co.uk</i>
Company Name:	<i>Peel Energy</i>
Do you believe that the proposed original or any of the alternatives better facilitate the Applicable CUSC Objectives? Please include your reasoning.	<p>For reference, the Applicable CUSC objectives are:</p> <p>(a) That compliance with the use of system charging methodology facilitates effective competition in the generation and supply of electricity and (so far as is consistent therewith) facilitates competition in the sale, distribution and purchase of electricity;</p> <p>(b) That compliance with the use of system charging methodology results in charges which reflect, as far as is reasonably practicable, the costs (excluding any payments between transmission licensees which are made under and accordance with the STC) incurred by transmission licensees in their transmission businesses and which are compatible with standard licence condition C26 requirements of a connect and manage connection);</p> <p>(c) That, so far as is consistent with sub-paragraphs (a) and (b), the use of system charging methodology, as far as is reasonably practicable, properly takes account of the developments in transmission licensees' transmission businesses;</p> <p>(d) Compliance with the Electricity Regulation and any relevant legally binding decision of the European Commission and/or the Agency. These are defined within the National Grid Electricity Transmission plc Licence under Standard Condition C10, paragraph 1*; and</p> <p>(e) Promoting efficiency in the implementation and</p>

	<p>administration of the CUSC arrangements.</p> <p>We agree with the view that the proposal has a positive impact on CUSC objectives, a, b and c and is not relevant to objectives d and e.</p> <p>We consider that the CMP303 proposal improves the baseline CUSC in relation to promoting competition and increasing cost reflectivity whilst having no adverse impacts of significance. We do not believe the existing generator local circuit charging methodology as relates to HVAC subsea cables and HVDC reflects the wider transmission system benefits that are accrued by such works and are not required by the generators currently being asked to pay for them. We believe CMP303 correctly identifies this defect and is correct in examining solutions to it.</p> <p>In relation to the current treatment of generator local circuit charges for HVAC subsea cables and HVDC we believe the CUSC is in defect by not recognising and accounting for the benefits accrued and not required by the generators using them. We therefore agree with CMP303 that costs associated with these additional benefits should be removed. We further note that these issues were debated during Project TransmiT and CMP213 but were not addressed at that time, Ofgem directing industry to address them at a later and more appropriate time which we consider is now.</p>
<p>Do you support the proposed implementation approach? If not, please state why and provide an alternative suggestion where possible.</p>	<p>We support the implementation approach and timetable proposed, agreeing with the urgent need to establish an outcome ahead of the CfD auctions. The issue of charging is critical to the economics of our projects and other projects on the islands and it is virtually impossible to prepare a competent and competitive CfD bid without a decision on CMP303.</p> <p>Our main concern with the CMP303 process is that it will be difficult to establish a clear answer in the proposed timescales.</p>
<p>Do you have any other comments?</p>	<p>We note the short timelines associated with this workgroup and have some concerns that there may be other benefits of HVAC subsea or HVDC links that have not yet been considered. Given the issues around timelines we are comfortable that the workgroup should progress as is but would seek assurance that further modifications in relation to other benefits could be raised at a later date.</p>

CUSC Code Administrator Consultation Response Proforma

CMP303 - Improving local circuit charge cost-reflectivity

Industry parties are invited to respond to this consultation expressing their views and supplying the rationale for those views, particularly in respect of any specific questions detailed below.

Please send your responses by **19 March 2019** to cusc.team@nationalgrid.com. Please note that any responses received after the deadline or sent to a different email address may not receive due consideration by the CUSC Modifications Panel when it makes its final determination.

These responses will be included in the Final CUSC Modification Report which is submitted to the CUSC Modifications Panel.

Respondent:	Paul Mott
Company Name:	EDF Energy
Do you believe that the proposed original or any of the alternatives better facilitate the Applicable CUSC Objectives? Please include your reasoning.	<p>Yes. Regarding (a) (<i>facilitates effective competition in the generation and supply of electricity</i>) – the original, and all WACMs except 4 to 7, have the potential to allow relevant generators to compete fairly in the market without being handicapped by paying extra costs unrelated to the export of their power. The concept that underlies WACMs 4 to 7 is being considered separately in the needs case process, and is referred to in the needs case minded-to Ofgem consultation documents issued this morning for two of the island links, “<i>SHEPD has submitted a proposal to contribute, on behalf of demand consumers, towards the cost of transmission links to reflect the avoided cost of replacing existing back-up generation on the Isles in future. We are considering the SHEPD proposal and we will shortly be publishing a separate document outlining our views</i>” – we take it that this separate document will be a consultation. CUSC says at 14.15.75 that AC cable and HVDC circuit expansion factors are to be calculated on a case by case basis using actual project costs, which presumably might be interpreted as altered (reduced) actual project costs, should Ofgem’s view of SHEPD’s proposals be positive.</p> <p>Regarding (b) (<i>.....charges which reflect, as far as is reasonably practicable, costs</i>), the original and WACMs allow relevant generators face a cost-reflective local circuit charge, without paying for extra costs unrelated to the export of their power. WACM4,5,6,7 however are neutral here, as it is not clear if they are workable or relevant.</p> <p>Regarding (c) (<i>...properly takes account of the developments in transmission licensees’ transmission businesses</i>), the original and the variants except 4 to 7 inclusive better meet this, as HVDC island links don’t exist yet, and the original, and others,</p>

	<p>cover these new links – so that such a development would be properly taken account of in a fair and cost-reflective manner. The original is not limited to HVDC though, and neither is the demand pro-rata WACM.</p> <p>(d) Compliance with the Electricity Regulation and (e) Promoting efficiency in the implementation and administration of the CUSC arrangements, do not seem relevant.</p> <p>Thus, overall the objectives are better met by the original and all WACMs except 4 to 7 inclusive, which do not better meet the objectives than original, or than baseline. WACM4 and the derivatives that include it (WACM 5, WACM 6, and WACM 7) have a drawback that it is not clear that the relevant numbers to make this WACM work for all island groups, or any, can be derived to same timeframe, and indeed in time for the critical May CFD auction. Such a timing discrepancy could impede competition, though we note the ongoing work being carried out by Ofgem. This risk could render WACM4 and the derivatives that include it, unable to effectively take forward cost-reflectivity. They attempt to address developments in transmission licensees’ transmission businesses, but do so ineffectively for the above reason.</p>
<p>Do you support the proposed implementation approach? If not, please state why and provide an alternative suggestion where possible.</p>	<p>We agree that CMP303 original proposal, and its WACMs, are all linked to an imminent date related issue; namely the date of the next CFD auctions that some local-circuit-connected generators, both AC and DC connected, will compete in to secure support, which is expected to be held by May 2019. In order to compete in this auction efficiently, this generation plant must be able to forecast the local circuit tariff element of their TNUoS charge (which could be materially impacted if this proposal was or was not approved). Therefore timing must allow for a decision by the Authority (with it to be implemented at the start of next charging year) at least a few weeks ahead of the auction. The timeframe is just adequate.</p>
<p>Do you have any other comments?</p>	<p>We would comment that the original, and WACMs 8, 1, 2, and 3, are relatively simpler and easier to administer, and the former two are applicable to a range of local circuits/types, wherever they are relevant.</p>

CUSC Code Administrator Consultation Response Proforma

CMP303 - Improving local circuit charge cost-reflectivity

Industry parties are invited to respond to this consultation expressing their views and supplying the rationale for those views, particularly in respect of any specific questions detailed below.

Please send your responses by **19 March 2019** to cusc.team@nationalgrid.com. Please note that any responses received after the deadline or sent to a different email address may not receive due consideration by the CUSC Modifications Panel when it makes its final determination.

These responses will be included in the Final CUSC Modification Report which is submitted to the CUSC Modifications Panel.

Respondent:	<i>Paul Jones</i> paul.jones@uniper.energy
Company Name:	<i>Uniper UK Ltd</i>
Do you believe that the proposed original or any of the alternatives better facilitate the Applicable CUSC Objectives? Please include your reasoning.	<p>It is not clear that a case has been made that this proposal would result in comparable treatment of subsea cables circuits compared with onshore equivalents in the context of the stated defect (ie that a circuit may have additional functionality over and above that needed for the specific generator concerned). No consideration is given under the present methodology as to why a certain technology and voltage level has been chosen for a specific circuit onshore either. Decisions are highly likely to have been for purposes other than just supporting the generation which uses the circuit, particularly as many of the routes will have been constructed a long time before many of the generators were built or even planned. The ICRP methodology does not look at those historic decisions and simply assesses whether an additional 1MW of generation would increase or decrease usage of the relevant circuits. It then allocates a cost or benefit based on that increased or decreased usage and the MWkm cost of the specific circuit type. Therefore, it is not clear that there is a defect to address.</p> <p>Arguably, making the changes proposed will reduce cost reflectivity as the circuit charges will not reflect the true cost of the assets concerned, particularly compared with the treatment of onshore assets. Reduction in cost reflectivity will result in inefficient locational decisions being made and undermine competition in the generation market.</p> <p>We certainly do not support the use of this modification to reopen the issue of whether or not converter stations should be included in the circuit charges for those assets. Dilution of the signal in relation to the cost of converter stations in this manner goes over and above the scope of the original defect, which simply refers to</p>

	<p>whether circuits were designed with additional functionality to that needed just to support the generation using them.</p> <p>A conscious decision was made by the Authority when approving the chosen solution for CMP213 to include 100 percent of these costs. Indeed, the Authority believed that the inclusion of these costs would be more cost reflective than not doing so and stated its view that <i>“the investment in the HVDC converter stations (including the specific design elements) for bootstrap and island links arise specifically to serve those links and provide the required transmission capacity. Furthermore, our general view is that it is appropriate that costs that are being triggered by users are paid for by those users, to promote cost reflectivity and ensure efficient decisions.”</i> (Ofgem’s CMP213 impact assessment Aug 2013)</p> <p>We note that the arguments for the exclusion of costs are largely based on analysis which was presented by some CMP213 workgroup members when also advocating such an approach. It should be noted that this view was only supported by a slight majority of CMP213 workgroup members. Out of the 20 options voted on which included some form of exclusion of converter costs, only 4 options received supporting votes from a majority of workgroup members. In these instances 8 out of 15 work group members supported these options (ie 53% of the total vote). It would be reasonable to conclude that the vote was split in these cases.</p> <p>Due to the reduction in cost reflectivity that this modification would represent and the detrimental effect this would have on competition, we consider that objectives a) and b) would be undermined if it were to be implemented.</p>
<p>Do you support the proposed implementation approach? If not, please state why and provide an alternative suggestion where possible.</p>	<p>No, we do not support implementation of the modification.</p>
<p>Do you have any other comments?</p>	<p>No thank you.</p>

CUSC Code Administrator Consultation Response Proforma

CMP303 - Improving local circuit charge cost-reflectivity

Industry parties are invited to respond to this consultation expressing their views and supplying the rationale for those views, particularly in respect of any specific questions detailed below.

Please send your responses by **19 March 2019** to cusc.team@nationalgrid.com. Please note that any responses received after the deadline or sent to a different email address may not receive due consideration by the CUSC Modifications Panel when it makes its final determination.

These responses will be included in the Final CUSC Modification Report which is submitted to the CUSC Modifications Panel.

Respondent:	<p><i>Please insert your name and contact details (phone number or email address)</i></p> <p>Michael Ferguson - michael.ferguson@sse.com, 07876 837 081 / Simon Redfern - simon.redfern@sse.com, 07881 343 355</p>
Company Name:	<p><i>Please insert Company Name</i></p> <p>Scottish Hydro Electric Power Distribution plc (CUSC party / signatory)</p>
Do you believe that the proposed original or any of the alternatives better facilitate the Applicable CUSC Objectives? Please include your reasoning.	<p><i>For reference, the Applicable CUSC Objectives for the Use of System Charging Methodology are:</i></p> <p><i>((a) That compliance with the use of system charging methodology facilitates effective competition in the generation and supply of electricity and (so far as is consistent therewith) facilitates competition in the sale, distribution and purchase of electricity;</i></p> <p><i>(b) That compliance with the use of system charging methodology results in charges which reflect, as far as is reasonably practicable, the costs (excluding any payments between transmission licensees which are made under and accordance with the STC) incurred by transmission licensees in their transmission businesses and which are compatible with standard licence condition C26 requirements of a connect and manage connection);</i></p> <p><i>(c) That, so far as is consistent with sub-paragraphs (a) and (b), the use of system charging methodology, as far as is reasonably practicable, properly takes account of the developments in transmission licensees' transmission businesses;</i></p> <p><i>(d) Compliance with the Electricity Regulation and any relevant legally binding decision of the European Commission and/or the Agency. These are defined within the National Grid Electricity Transmission plc Licence under Standard Condition C10, paragraph 1*; and</i></p> <p><i>(e) Promoting efficiency in the implementation and administration of the CUSC arrangements.</i></p> <p>*Objective (d) refers specifically to European Regulation 2009/714/EC. Reference to the Agency is to the Agency</p>

for the Cooperation of Energy Regulators (ACER).

We set out in our previous response that we consider that charging for HVDC links should be cost reflective, with potential for customer / DSO / NGESO / other contributions towards costs, or otherwise allocations of those costs to those consumers who benefit, where justified. We consider that this arrangement better enables objective (a) in more effectively facilitating competition in the generation and supply of electricity.

The CMP 303 original and alternative proposals *in general* better facilitate objective (b) than the baseline *to the extent that* the charges continue to reflect the costs incurred by transmission licensees, and lead to costs being shared more equitably among relevant parties who benefit from shared use of a given asset. However, we don't believe that the proposals adequately bear a whole system future in mind in their consideration of this defect.

The CMP 303 proposals identify two broad principles for achieving cost-reflectivity: i) the identification and carve-out of relevant transmission asset / equipment costs such as converter and bidirectionality costs from TNUoS charges, where it is determined that these assets are not required, or are not required in entirety, by generators; and ii) the application of a value for the provision of supply / services from an HVDC system such as "making supply" to an island distribution system, also applied to reduce TNUoS charges.

We note that most of the alternatives focus on carving out the cost of additional functionality. This is reasonable, and moves towards cost-reflectivity, but does not go far enough in accommodating the concept of value to wider users in meeting need, as envisaged under whole system principles, which should always be considered in the context of the cost of alternative ways by which that need could be met. This is a forward-looking approach which ensures better readiness with future whole system proposals.

The original recommended proposal of CMP 303 identifies the requirement to carve out "extra costs" of "additional functionality" which are "unrelated from the generators needs" from the costs borne by the generators who have requested associated transmission links (item i) above). It is proposed that costs relating to the function of bidirectionality are removed at a minimum. We agree with cost-sharing, cost-reflective charging in principle, and that a customer should not be faced with undue costs which are unrelated to the service it requires, and it is for the TO, NGESO, generators and Ofgem to determine specific arrangements. We consider that the original and each of the revised WACMs have some merit in seeking to align TNUoS charges with this principle. However we would note that WACMs which propose cost carve-outs risk causing discriminatory effects if the identification of relevant assets / services is not managed carefully to avoid mis-allocation of costs to the various consumer groups. The involvement of the DSO / DNO or other relevant consumer at this stage in order to confirm need / benefit / value could, again, mitigate this issue.

With regards to item ii) above (which it may be appropriate to apply in addition to i), as proposed in various WACMs) where it

is established that a third party may benefit from an HVDC system, we recommend that it is for the relevant customer (e.g. DSO / NGESO) to determine its need, and to make a valuation of the relevant assets / services which would be used by / of benefit to those customers in meeting that need. There should also be a correct allocation of cost, applied towards those customers. We believe this better aligns with both cost-reflectivity and whole system objectives, which are envisaged to see “network operators...identify and pursue solutions that can benefit multiple parties across the system”, with “...Parties contributing efficient costs to reflect the benefits they receive in delivering their obligations and outputs”.¹

We note the position reflected in the consultation document that,

“Whilst the Workgroup found some merit in the alternative request provided by SHEPD, this was not taken forwards by the Workgroup in the form proposed. During Workgroup 5, the Workgroup contacted SHEPD to discuss the proposal further. After the discussions, it was decided that the aspects of the alternative request should to be considered as a formal WACM (it subsequently became WACM4 – see below for further details).”²

We reiterate our view that **our alternative approach should be reflected in any CMP303 proposal taken forward to implementation**, in order to provide that the benefit or value of an asset and / or services to distribution customers / users is taken into account. Doing so would take proper account of specific need and, following whole system principles, would be more likely to result in a cost efficient / cost reflective outcome. We maintain the recommendation that CMP303 is modified to incorporate this process of engagement with, and determination of need by, relevant parties / customers; and that any CUSC modification taken forward, including definitions, is drafted such that it can accommodate the effect of an offset contribution made by a DSO / DNO on behalf of its consumers, where an efficient whole system arrangement has been identified and the relevant methodology for / value of a contribution has been agreed with Ofgem.

We consider that modifications / clarifications to the CMP 303 proposals taken forward to this effect would more closely align with whole system principles and would better facilitate objective (c).

As noted in our original response, SHEPD has been developing proposals for an enduring solution for Shetland over the past several years, in the context of its distribution licence obligation. SHEPD has over the past year carried out detailed analysis and has developed comprehensive methodologies with independent industry consultants which i) identify island distribution system need, ii) identify and value avoided cost benchmarks, iii) value services from a transmission link to a distribution system and iv) identify how a contribution made by the DSO for the benefit of distribution consumers would be paid for by those consumers. SHEPD has also progressed proposals, with BEIS and Ofgem,

¹ [Ofgem consultation on licence conditions and Guidance for network operators to support an efficient, coordinated, and economical Whole System](#), p.6-7

² [CMP303 - Improving local circuit charge cost-reflectivity: Stage 04: Code Administrator Consultation](#), p.19

	<p>around how relevant costs would be recovered from distribution or GB customers.</p> <p>It is expected that Ofgem will consult on SHEPD's recommendation and its own position on an island contribution methodology in March 2019. Ofgem has noted its ability, in the existing (challenging) timescales, to reach a decision before the expected launch of the 2019 CfD auction (expected in May 2019). SHEPD's methodologies and proposed contribution values will be shared for stakeholder assessment and feedback at this point. We note that SHEPD has already carried out engagement with NGES, BEIS, the Scottish Government, island councils and MPs / MSPs and all relevant Shetland, Western Isles and Orkney developers on the contribution methodology, value, and pan-island approach.</p> <p>We therefore continue to recommend that the CMP 303 proposals are articulated and implemented in such a way as to clearly define the role and involvement of the relevant customer in identifying its need and its contribution towards costs for shared use of an asset. In the cases of HVDC transmission links to Shetland and the Western Isles, this customer would be SHEPD (and potentially also NGESO, and perhaps others), and we suggest SHEPD's methodologies should determine the contribution for meeting distribution system needs.</p> <p>We have not commented on objectives (d) and (e).</p>
<p>Do you support the proposed implementation approach? If not, please state why and provide an alternative suggestion where possible.</p>	<p>Again, we agree with the urgency of the implementation timing, driven by the impending CfD auction, and the imperative that developers must have clarity on TNUoS charges ahead of this – there is a consensus on this point among respondents.</p> <p>We consider that the legal text proposed for WACM 4 looks sensible as a starting point, but would strongly suggest that it is further refined by a solicitor with NGESO, Ofgem and relevant stakeholders in order to ensure it is fully fit for purpose. This may include adding definitions (e.g. for "functionality") and taking into account Ofgem's consultation and determination on SHEPD's Recommendation. SHEPD would be very happy to participate in such a working group for this purpose. It could also be sensible to develop a working document which sits alongside the CUSC to provide more detailed commentary and interpretation on its implementation.</p>
<p>Do you have any other comments?</p>	<p>We would like to provide clarification on several points in relation to our workstream, and how this has been translated into WACM 4 (5, 6), leading to incorrect assumptions made by stakeholders which have been reflected in the consultation document.</p> <ol style="list-style-type: none"> 1. <u>Is a DNO offset (per WACM4 and associated WACMs) discriminatory if different contribution values are applied across the different Scottish islands?</u> <p>SHEPD understands the sensitivity to this issue. SHEPD's methodology is based on an assessment of distribution</p>

system need, and the benefits / value to the system that a transmission link would bring. The cost of the “next-best alternative” is also relevant, in order to provide context in terms of how much a party would have to pay for goods or services in the absence of the relevant transmission link solution, and how to determine what is best value. (For example, as noted in SHEPD’s response to the Stage 2 consultation, the next-best alternative cost SHEPD has identified to provide the same services as could be provided by the transmission link is c.£400m. Therefore there is a significant level of cost which would be avoided in pursuing a whole system solution.) There are inevitably and unarguably different levels of need and, hence, benefit and value of transmission solutions to different groups of distribution consumers.

Several of the WACMs apply this principle:

- WACM 8 proposes a calculation based on the *specific* share of use of the link for import to distribution consumers, “*calculated using the import / generation export ratio. The import shall be calculated based on the maximum anticipated import needs*”.³
- WACM 3 proposes a case-by-case assessment of the “additional functionality” in terms of ancillary services to the wider network (reactive power, voltage control etc).⁴
- WACMs 1 and 2 reflect on project-specific converter cost deductions.

These methodologies correctly identify that the costs of, need for and value of an asset / benefit / service vary from situation to situation, and that **the impact on TNUoS charged in different situations is simply a by-product of this assessment.**

SHEPD would be positively discriminating, and acting outside of its licence obligations, if a contribution was proposed which was disproportionate to the need, value and benefit to its consumers. We note that the methodology and value have been shared with Ofgem and other stakeholders, and will be consulted upon shortly.

We would note again that WACMs which propose cost carve-outs risk causing discriminatory effects if the identification of relevant assets / services is not managed carefully, to avoid mis-allocation of costs to consumer groups. The involvement of the DSO / DNO or other relevant consumer at this stage in order to confirm need / benefit / value could, again, mitigate this issue.

³ CMP303 - Improving local circuit charge cost-reflectivity: Stage 04: Code Administrator Consultation, p.21

⁴ Ibid., p.20

2. Does the contribution methodology apply only to the Shetland scenario?

No. We have provided Ofgem with contribution methodologies and values for Shetland, the Western Isles and Orkney. Naturally, these values vary in each situation, reflecting on the level of need, and value / benefits which a transmission link would bring, taking into account any existing infrastructure in these locations.

3. Will contribution values for all islands be available in the required timeframes?

SHEPD has been working on its contribution methodology since the beginning of 2018. We submitted our formal Recommendation to Ofgem in November 2018, further to engagement with them through that year.

We have provided Ofgem with contribution methodologies and values for Shetland, the Western Isles and Orkney. SHEPD's ability to make the island contributions is subject to relevant regulatory approvals, including on the methodology, values, and cost recovery arrangements, where relevant.

Our Recommendation aligns with the timeframe for CMP 303, in that we have set out that a decision by Ofgem is required by May 2019 in order for generators to progress with their CfD bidding strategies with certainty of the related TNUoS impact. Ofgem has confirmed its ability to make a determination on our Recommendation in this timeframe.

4. Has WACM 4 / the Shetland DSO contribution workstream been developed with Ofgem and stakeholder engagement?

Yes. The DSO offset principle within WACM 4 was included in some form in Alternative 2 included within the Stage 02 Workgroup Consultation proposal⁵, and has been refined in response to SHEPD's feedback to that document. The alternative proposals raised in relation to CMP 303 have been considered by the Working Group, including Ofgem and NGESO, and the public through consultation.

As noted above, SHEPD's proposals have been shared with Ofgem since the beginning of 2018, and other stakeholders at relevant points in time in later 2018 and early 2019. Ofgem has reviewed the detail of our methodologies and assumptions. The other stakeholders we have shared our proposals with include National Grid ESO; BEIS; the Scottish Government; Shetland, Western Isles and Orkney councils, MPs and MSPs; and all of the transmission-connecting and several distribution-level generators on those islands, including EdF, Forsa, Peel, Statkraft, Viking, DP Energy,

⁵ CMP303 – Improving local circuit charge cost-reflectivity: Stage 02 – Workgroup Consultation

	<p>Hoolan and Aquatera.</p>
--	-----------------------------

Ofgem will shortly consult on the proposals publicly.

CUSC Code Administrator Consultation Response Proforma

CMP303 - Improving local circuit charge cost-reflectivity

Industry parties are invited to respond to this consultation expressing their views and supplying the rationale for those views, particularly in respect of any specific questions detailed below.

Please send your responses by **19 March 2019** to cusc.team@nationalgrid.com. Please note that any responses received after the deadline or sent to a different email address may not receive due consideration by the CUSC Modifications Panel when it makes its final determination.

These responses will be included in the Final CUSC Modification Report which is submitted to the CUSC Modifications Panel.

Respondent:	<i>Garth Graham (garth.graham@sse.com)</i>
Company Name:	<i>SSE Generation Ltd.,</i>
Do you believe that the proposed original or any of the alternatives better facilitate the Applicable CUSC Objectives? Please include your reasoning.	<p>For reference, the Applicable CUSC objectives are:</p> <p>(a) That compliance with the use of system charging methodology facilitates effective competition in the generation and supply of electricity and (so far as is consistent therewith) facilitates competition in the sale, distribution and purchase of electricity;</p> <p>We believe that CMP303 Original along with WACM1, WACM3 WACM4, WACM5 and WACM7 will ensure that the use of system charging methodology better facilitates effective competition. This is because the individual elements of each of the proposals; either as 'stand-alone' or in 'combination'; ensure that the use of system charges are more cost reflective and as such this is better in terms of facilitating effective competition.</p> <p>We believe that WACM2, WACM6, WACM8 and WACM9 do not better facilitate effective competition.</p> <p>(b) That compliance with the use of system charging methodology results in charges which reflect, as far as is reasonably practicable, the costs (excluding any payments between transmission licensees which are made under and accordance with the STC) incurred by transmission licensees in their transmission businesses and which are compatible with standard licence condition C26 requirements of a connect and manage connection);</p> <p>We believe that CMP303 Original along with WACM1, WACM3 WACM4, WACM5 and WACM7 will ensure that the use of system charging methodology is better in terms of cost</p>

reflectivity. This is because the individual cost elements of each of the proposals; either as 'stand-alone' or in 'combination'; will be charged, as appropriate, to the users that gave rise to those costs, thus ensuring that the use of system charges are more cost reflective.

Thus, the Original, with its application of the additional costs of bi-directional (compared to mono-directional) to the users who give rise to those costs, is more cost reflective than the current Baseline CUSC.

WACM1 includes the Original solution but also incorporates the charging of half the costs of the HVDC convertor station element in a similar way to the equivalent HVAC transmission system element. The 50% figure has been sourced from an internationally recognised centre of expertise on the topic (namely CIGRE). Therefore, this WACM1 approach ensures that users who give rise to the convertor stations costs are charged accordingly, which is more cost reflective than the current Baseline CUSC.

WACM3 includes the Original solution but also incorporates the identification of additional functionality of HVDC links which are unrelated to the needs associated with generation and charges the costs associated with that additional functionality appropriately. Therefore, this WACM3 approach ensures that users who give rise to the additional functionality costs are charged accordingly, which is more cost reflective than the current Baseline CUSC.

WACM4 includes the Original solution but also incorporates ability for the identification, by the Authority, of additional benefits of (transmission) HVDC links when compared with an equivalent (distribution) link, if appropriate, and thus provides a cost reflective offset to be applied. Therefore, this WACM4 approach ensures that users of the transmission system are charged appropriately, which is more cost reflective than the current Baseline CUSC.

WACM5 is a combination of WACM1 and WACM4 and as such it incorporates all the additional cost reflective benefits that these two 'stand-alone' proposals have in terms of convertor station costs and an (Authority determined) appropriate offset associated with the avoided costs for a distribution link. Therefore, this WACM5 approach ensures that users of the transmission system are charged appropriately, which is more cost reflective than the current Baseline CUSC.

WACM7 is a combination of WACM3 and WACM4 and as such it

incorporates all the additional cost reflective benefits that these two 'stand-alone' proposals have in terms of identifying additional functionality for HVDC links and an (Authority determined) appropriate offset associated with the avoided costs for a distribution link. Therefore, this WACM7 approach ensures that users of the transmission system are charged appropriately, which is more cost reflective than the current Baseline CUSC.

We believe that WACM2, WACM6, WACM8 and WACM9 do not better facilitate cost reflective charging for use of system charges.

(c) That, so far as is consistent with sub-paragraphs (a) and (b), the use of system charging methodology, as far as is reasonably practicable, properly takes account of the developments in transmission licensees' transmission businesses;

We believe that CMP303 Original along with WACM1, WACM3 WACM4, WACM5 and WACM7 will ensure that the use of system charging methodology as far as is reasonably practicable properly takes account of developments in the transmission business; as regards the development of HVDC links in terms of demand and generation locations; within the transmission licensees area of operations.

We believe that WACM2, WACM6, WACM8 and WACM9 do not better ensure that the use of system charging methodology as far as is reasonably practicable properly takes account of developments in the transmission business.

(d) Compliance with the Electricity Regulation and any relevant legally binding decision of the European Commission and/or the Agency. These are defined within the National Grid Electricity Transmission plc Licence under Standard Condition C10, paragraph 1*; and

We believe that CMP303 Original along with WACM1, WACM3 WACM4, WACM5 and WACM7 will achieve a use of system charging methodology for GB that is in compliance with EU law, in terms of the legally binding EU Renewable Energy Directive (2009/28/EC)¹.

In this regard, it is important to recognise Recital (63), which states that:

¹ <https://eur-lex.europa.eu/legal-content/EN/TXT/PDF/?uri=CELEX:32009L0028&from=EN>

“Electricity producers who want to exploit the potential of energy from renewable sources in the peripheral regions of the Community, in particular in island regions and regions of low population density, should, whenever feasible, benefit from reasonable connection costs in order to ensure that they are not unfairly disadvantaged in comparison with producers situated in more central, more industrialised and more densely populated areas.”

This is a situation that self-evidently exists for the costs arising from the proposed Shetland and Western Isles HVDC links (which are both island regions and regions of low population density).

Therefore, potential auction participation from renewable energy sources from those locations will be achieved to a greater extent (than the current CUSC Baseline) by CMP303 Original along with WACM1, WACM3 WACM4, WACM5 and WACM7 which, in turn, demonstrates compliance with EU law.

Furthermore, Article 16 of the Directive sets out, in the following terms, that:

(i) *“[Article 16(7)] Member States shall ensure that the charging of transmission and distribution tariffs does not discriminate against electricity from renewable energy sources, in particular electricity from renewable energy sources produced in peripheral regions, such as island regions, and in regions of low population density”* (a situation that exists for the proposed Shetland and Western Isles HVDC links) and;

(ii) *“[Article 16(3)] standard rules relating to the bearing and sharing of costs of technical adaptations, such as grid connections and grid reinforcements...[and that] Those rules shall be based on objective, transparent and non-discriminatory criteria taking particular account of all the costs and benefits associated with the connection of those producers to the grid and of the particular circumstances of producers located in peripheral regions and in regions of low population density.”* (a situation that exists for the proposed Shetland and Western Isles HVDC links).

(e) Promoting efficiency in the implementation and administration of the CUSC arrangements.

We believe that the Original and all nine WACMs are neutral in terms of better achieving this applicable objective.

Do you support the proposed

We do support the proposed implementation approach as set out

<p>implementation approach? If not, please state why and provide an alternative suggestion where possible.</p>	<p>in Section 8 of the consultation document.</p> <p>We would, in particular, wish to re-emphasise the point we (and many other respondents to the Workgroup Consultation) made previously around the time criticality of a decision on CMP303 ahead of the forthcoming auction (the date for which has been set by the Secretary of State and not by any potential auction participant) as the decision, on CMP303, will have a materially important effect on auction participants that arise “<i>in particular [with] electricity from renewable energy sources produced in peripheral regions, such as island regions, and in regions of low population density</i>”, namely from Shetland and the Western Isles.</p>
<p>Do you have any other comments?</p>	<p>We note that Ofgem has today (19th March 2019) issued a consultation, which can be found at:</p> <p>https://www.ofgem.gov.uk/publications-and-updates/shetland-transmission-project-consultation-final-needs-case-and-delivery-model</p> <p>For the avoidance of doubt we have not been able to fully review or consider that Ofgem consultation document today or take it into account when preparing this response to the CMP303 consultation.</p> <p>We have no additional comments at this time.</p>

CUSC Code Administrator Consultation Response Proforma

CMP303 - Improving local circuit charge cost-reflectivity

Industry parties are invited to respond to this consultation expressing their views and supplying the rationale for those views, particularly in respect of any specific questions detailed below.

Please send your responses by **19 March 2019** to cusc.team@nationalgrid.com. Please note that any responses received after the deadline or sent to a different email address may not receive due consideration by the CUSC Modifications Panel when it makes its final determination.

These responses will be included in the Final CUSC Modification Report which is submitted to the CUSC Modifications Panel.

Respondent:	<i>Aaron Priest, Head of Development and Strategy, Viking Energy Shetland, North Ness Business Park, Lerwick, Shetland ZE1 0LZ on behalf of Viking Energy Windfarm LLP. aaron.priest@vikingenergy.co.uk</i>
Company Name:	<i>Viking Energy Wind Farm LLP</i>
Do you believe that the proposed original or any of the alternatives better facilitate the Applicable CUSC Objectives? Please include your reasoning.	<p>For reference, the Applicable CUSC objectives are:</p> <p>(a) That compliance with the use of system charging methodology facilitates effective competition in the generation and supply of electricity and (so far as is consistent therewith) facilitates competition in the sale, distribution and purchase of electricity; <i>Viking Energy Wind Farm LLP (VEWF) believes that the proposed original and alternatives WACM1, WACM3, WACM4, WACM5 and WACM 7 would have a positive impact in better facilitating competition (and cost reflectivity). Currently TNUoS charges for HVDC circuits include costs which are not properly cost reflective and which result in distortion of competition by disadvantaging those generators who have to pay costs which are excluded on equivalent HVAC circuits. Fairer competition (and cost reflectivity) would be facilitated by recovering costs which more directly reflect the contractual export requirements of the generator on HVDC circuits. All the WACMs listed above contain this fundamental principle, as they contain the proposed original, and this should be borne in mind when considering other aspects of the WACMs.</i></p> <p><i>WACM1 includes the original, but also seeks a more equitable TNUoS charging arrangement for HVDC converter stations. Work conducted by CIGRE, in direct follow-up to Project TransmiT, provides solid evidence that approximately half of the costs of HVDC converter stations can be attributed to components and functions which have the characteristics of HVAC substations. The cost of these</i></p>

HVDC components and functions are currently unfairly recovered via local circuit charging arrangements on HVDC circuits, whilst for HVAC substations these costs are excluded from local circuit charges. As things stand, competition is distorted by the failure to act on this evidence and this perpetuates an inequality in charging arrangements between HVAC and HVDC circuits. Unequal treatment distorts competition (and cost reflectivity).

WACM3 contains the original, but also seeks to identify additional functionality of HVDC circuits not required by exporting generators and not charged to exporting generators on equivalent HVAC circuits. These functions are reactive power, voltage control, power flow control and black start. For HVDC circuits the provision of these wider functions is charged to exporting generators within the local circuit charge, whilst on HVAC circuits they are not. Again, unequal treatment distorts competition (and cost-reflectivity).

WACM4 contains the original, but recognises the additional function of island HVDC links in underpinning island security of supply. It recommends offsetting a capital value for this function which would be determined by the Authority. Competition (and cost-reflectivity) is facilitated under such an arrangement by recovering costs which more directly reflect the needs of the exporting generator.

WACM5 is a hybrid of the original, WACM1 and WACM4. All these elements would better facilitate competition (and cost-reflectivity) for the reasons laid out above and in the Final Workgroup Report. In capturing these separate elements, and with the converter station argument backed by CIGRE's evidence, WACM5 represents VEWf LLP's best option in better facilitating the relevant CUSC objectives of competition and cost reflectivity.

WACM7 is a hybrid of the original, WACM3 and WACM4. Again, as laid out above and in the Final Workgroup report, all these constituent parts would better facilitate competition (and cost reflectivity).

(b) That compliance with the use of system charging methodology results in charges which reflect, as far as is reasonably practicable, the costs (excluding any payments between transmission licensees which are made under and accordance with the STC) incurred by transmission licensees in their transmission businesses and which are compatible with standard licence condition C26 requirements of a connect and manage connection); *VEWF believes that the proposed original and alternatives WACM1, WACM3, WACM4,*

WACM5 and WACM 7 would have a positive impact in better facilitating cost reflectivity. Current HVDC TNUOS charging arrangements include charges which are not properly cost reflective and which are discriminatory when compared to treatment of equivalent export via HVAC circuits. The answers provided to (a) above apply equally to better facilitation of cost reflectivity.

WACM5 is a hybrid of the original, WACM1 and WACM4 All its constituent elements better facilitate cost-reflectivity (and competition) for the reasons laid out in (a) above and in the Final Workgroup Report. In capturing these separate elements, and with the converter station argument backed by CIGRE's evidence, WACM5 represents VEWf LLP's best option in better facilitating relevant CUSC objectives of competition and cost-reflectivity.

(c) That, so far as is consistent with sub-paragraphs (a) and (b), the use of system charging methodology, as far as is reasonably practicable, properly takes account of the developments in transmission licensees' transmission businesses; *VEWF believes that the proposed original and alternatives WACM1, WACM3, WACM4, WACM5 and WACM 7 would help to ensure that the CUSC and use of system charging methodology treats HVDC links in a fair, more cost-reflective and non-discriminatory manner, as required within TOs' transmission licences.*

(d) Compliance with the Electricity Regulation and any relevant legally binding decision of the European Commission and/or the Agency. These are defined within the National Grid Electricity Transmission plc Licence under Standard Condition C10, paragraph 1*; *For the reasons we detail in our answer to Q3 below, VEWf believes that the original and alternatives WACM1, WACM3, WACM4, WACM5 and WACM 7 would have a positive impact in better facilitating this objective as they ensure compliance with relevant legally binding EU law, namely EU Renewable Energy Directive (2009/28/EC) and in particular the two references (3 & 7) we quote in our answer to Q3 below. and*

(e) Promoting efficiency in the implementation and administration of the CUSC arrangements. *VEWF believes that the original and the WACMs are neutral in terms of this objective.*

<p>Do you support the proposed implementation approach? If not, please state why and provide an alternative suggestion where possible.</p>	<p><i>VEWF agrees that the implementation process and date should be compatible with the requirements of the announced May 2019 CfD auction. VEFW agrees that, if the CfD auction is to run fairly and competitively, all bidding plant must be able to properly understand and forecast the local circuit element of their TNUoS charge. Therefore a decision is required by the Authority in time for parties to take that decision into account when they participate in that auction.</i></p>
<p>Do you have any other comments?</p>	<p><i>VEWF wishes to reiterate its belief that there is strong evidence to suggest discriminatory TNUoS charging arrangements for HVDC circuits under the CUSC, as it stands, when compared to the treatment of HVAC circuits. VEFW wishes to reiterate that these arrangements are not properly cost reflective. Discrimination, and arrangements which are not properly cost reflective, would constitute a breach of GBSO licence conditions and need to be addressed and rectified quickly. It is arguable that the forthcoming May 2019 CfD auction's fairness and competitiveness could be called into question unless these anomalies are rectified quickly.</i></p> <p><i>The following text is lifted from the EU Renewable Energy Directive (2009/28/EC), which, according to the European Union (Withdrawal) Act 2018 will continue to apply post-Brexit.</i></p> <p><i>“3. Member States shall require transmission system operators and distribution system operators to set up and make public their standard rules relating to the bearing and sharing of costs of technical adaptations, such as grid connections and grid reinforcements, improved operation of the grid and rules on the non-discriminatory implementation of the grid codes, which are necessary in order to integrate new producers feeding electricity produced from renewable energy sources into the interconnected grid.</i></p> <p><i>Those rules shall be based on objective, transparent and non-discriminatory criteria <u>taking particular account of all the costs and benefits associated with the connection of those producers to the grid and of the particular circumstances of producers located in peripheral regions and in regions of low population density.</u> Those rules may provide for different types of connection.”</i></p> <p><i>“7. Member States shall ensure that the charging of transmission and distribution tariffs does not discriminate against electricity from renewable energy sources, <u>including in particular electricity from renewable energy sources produced in peripheral regions, such as island regions, and in regions of low population density.</u>”</i></p>

In regard to these two, separate, underlined legal obligations above, we would remind the CUSC Panel and the Authority that, in the case of the HVDC links to Shetland (and the Western Isles) these involve “in particular electricity from renewable energy sources produced in peripheral regions, such as island regions, and in regions of low population density”.



Xero Energy Limited
60 Elliot Street
Glasgow G3 8DZ
United Kingdom
Tel: +44 (0)141 221 8556
www.xeroenergy.co.uk
Reg. SC313697 in Scotland

BRIEFING NOTE

PROJECT: CMP 303
SUBJECT: WACM 3 - Wider system benefits of HVDC
CLIENT: Not applicable
REFERENCE: BRN 1234/028/001D
CLIENT REFERENCE: Not applicable

Document History

V	AUTH	VERF	APPR	DATE	NOTES
A	NCS	ES	NCS	28/11/2018	Draft version only.
B	NCS	FW	NCS	05/12/2018	First draft issue for CMP 303 working group only.
C	NCS	FW	NCS	04/02/2019	Updated WACM references.
D	NCS	FW	NCS	04/09/2019	Updated from discussion paper to position paper using the proposed Western Isles HVDC link as an example.

Notes

This document and any accompanying documents are to be distributed to members within the named client organisation only and are not to be distributed to other third parties or the public without express written consent from Xero Energy Limited. Xero Energy Limited does not accept responsibility for the application or use made of information or advice supplied. Such responsibility remains with the client.

1 Introduction

1.1 General

This short note has been drafted by Dr Nigel Scott of Xero Energy Limited to constitute and explain a WACM to the CMP 303 process. This WACM is 3.

The original CMP 303 text identifies the CUSC defect as follows.

When a new local circuit is built to enable the export of new generation, extra costs may be incurred on additional functionality that is unrelated to the needs of said generation. ... Absent clarification of the exclusion of these extra costs, they are very likely to be included in the actual costs used to calculate the expansion factor and hence the relevant local circuit charge, meaning that relevant generators are facing a local circuit charge that is not fully cost-reflective.

The proposed amended CUSC text is as follows.

14.15.75 AC sub-sea cable and HVDC circuit expansion factors are calculated on a case by case basis using actual project costs (Specific Circuit Expansion Factors), except that these project costs should only include costs relevant to and needed by the connected generators. The incremental cost of any extra functionality that the TO chooses to add, of wider benefit, should not be included.

14.15.76 Subject to 14.15.75, for HVDC circuit expansion factors both the cost of the converters and the cost of the cable are included in the calculation.

1.2 Overview of WACM 3

This WACM 3 identifies additional functionality of HVDC local circuits that is unrelated to the needs of the generation whose export is facilitated by the HVDC local circuits. It proposes to quantify the costs of this additional functionality by examining the costs of equivalent plant or services. The costs of the equivalent plant or services are then deducted from the HVDC costs entered into the generator local circuit TNUoS charge calculation to reduce the charge the relevant generators pay.

1.3 Overview of additional functionality

1.3.1 Included in this note

The additional functionality identified and discussed further in this note is as follows.

1. Reactive power provision
2. Voltage control
3. Power flow control (quadrature booster functionality)
4. Black start

The additional functionality is provided as part of the HVDC link and provides wider transmission (and whole system) benefits, which are unrelated to the needs of the generators. Were this functionality provided separately in the wider system, it would have a cost associated with it. This cost should therefore be removed from the generator local circuit charges as it is not relevant to the generator and presents a benefit to the wider system, which the relevant HVDC local circuit generators should not be paying for.

1.3.2 Excluded from this note

It should be noted that there is other functionality that could be considered additional, but at present this note is focused on the above as these are expected to be the key additional functions which constitute the largest costs. Such other additional functionality includes items such as power quality improvement, fault level boosting, stability control and more. A non-exhaustive list of other functionalities is included as Appendix A.

It should further be noted that other proposals under CMP 303 cover the aspect of import or demand supply as additional functionality. This note therefore assumes that aspects related to this, such as demand security, reinforcement avoidance and standby diesel generator displacement/replacement, are effectively covered elsewhere.

1.4 Contents of this note

This note is set out as follows.

- Section 1 – Introduction (this section)
- Section 2 – HVDC TNUoS charging history
- Section 3 – Additional functionality
- Section 4 – Quantifying the costs
- Section 5 – Cost deduction impact on TNUoS
- Section 6 - Summary
- Section 7 – References
- Section 8 – Appendix A – Other benefits of HVDC
- Section 9 – Appendix B - Acronyms

2 HVDC TNUoS charging history

2.1 General

Until recently, there were no HVDC links within the GB transmission system, only HVDC interconnections from other jurisdictions. Therefore, local circuit use of system charging of HVDC links has only been considered in this context, and in relatively simple and narrow terms.

2.2 Project TransmiT

Between 2010 and 2012, a review (Project TransmiT) of transmission use of system charging arrangements (TNUoS) for generators was undertaken by the regulator, Ofgem. This was primarily driven by the increase of intermittent wind generation in relatively remote locations such as Scotland. This work resulted in a change to the general charging arrangements and ultimately to the current local circuit treatment of HVDC links. The focus of this review was not however the treatment of HVDC, although it did feature.

In 2011, and as part of Project TransmiT, Ofgem considered whether HVDC converter station costs should be excluded when calculating wider tariffs where the link is in parallel with the existing system [1]. Ofgem consulted on this in May 2012 and subsequently directed National Grid Electricity System Operator to consider this case along with the wider benefits and costs relating to local circuit links as part of a CUSC modification process to revise charging arrangements [2]. This became the CMP213 process led by National Grid Electricity System Operator, with the focus again on the general use of system charging arrangements and not the treatment of HVDC, although it was duly considered.

2.3 CMP213

CMP213 was the National Grid Electricity System Operator led industry process to modify the charging arrangements as a follow up to Project TransmiT. As part of the initial scoping of options, National Grid Electricity System Operator examined cases where various percentages of the HVDC converter station costs were socialised [3] [4]. These cases were considered for both bootstrap (parallel) and local circuit (radial) HVDC links.

National Grid Electricity System Operator published a working group report in June 2013 which included a section on the wider benefits of Voltage Source HVDC with specific reference to the wider benefits of the Western Isles HVDC link [5]. This section was primarily based on a paper by SSE and ABB and set out a list of benefits. Despite the evidence provided in this National Grid Electricity System Operator assessment, and counter to its considerations published in March 2012, Ofgem came to a view in August 2013 [6] that socialisation of converter costs was not appropriate.

The consultation responses received by Ofgem did highlight a wide variety of potential wider benefits from HVDC, but it seems that the benefits were not quantified and there was insufficient appetite to pursue them given the focus of CMP213 was on the more general charging arrangements and this in itself was a major issue for industry. Ofgem did however note that it was open to further evidence on the wider system benefits of HVDC.

The wider system benefits from HVDC were again touched on during a further consultation round in April 2014 [7] with a number of respondents again highlighting the wider benefits. In its July 2014 decision [8], Ofgem again stated it had not seen enough evidence to further

consider socialisation of HVDC (converter) costs. Ofgem additionally considered that wider socio-economic benefits were beyond its remit and suggested National Grid Electricity System Operator and industry tackle the issues around the wider benefits of HVDC at a later and more appropriate date [7].

2.4 Post CMP213

The charging arrangements that CMP213 developed have been implemented and there have been a wide variety of amendments to them over the last few years. There has however been little follow up to the CMP213 discussions on HVDC wider benefits and charging, bar the CMP301 CUSC clarification still in process at time of writing. Given there are now two operational HVDC links in the GB system and further parallel and radial local circuit HVDC links are likely, it would seem an appropriate time to revisit the charging arrangements for HVDC.

2.5 Current charging position

In calculating the local circuit generator charge from an HVDC link, Section 14 of the CUSC requires that the cost of the converters and cables is used.

In comparing the HVDC charging regime to the onshore charging regime for AC systems it can be seen that the AC regime is quite different in that no substation assets are normally included, just the overhead line or underground cable circuits themselves. Indeed, the relevant AC substation assets which would be needed to provide the additional functionality that the HVDC links bring are not included in local circuit charges (or wider zonal charges). This discrepancy suggests that there is an issue that needs to be addressed in making the current HVDC local circuit charging regime more cost reflective and the overall charging regime less discriminatory against HVDC systems and the users (generators) paying for them more directly through local circuit charges.

3 Additional functionality

3.1 Introduction

This section of the report examines four categories of additional functionality that a typical local circuit HVDC link provides. This note is focused on the more modern Voltage Source Converter technology which has just been installed to interconnect northern and north-eastern Scotland across the Moray Firth, i.e. Caithness-Moray HVDC link, and may be rolled out for other mainland to mainland transmission system uses. It is also proposed for various local circuit uses, e.g. the Western Isles of Scotland and Shetland.

3.2 Reactive power

National Grid Electricity System Operator Electricity System Operator (NGESO) is seeing an increasing need to absorb reactive power. This is a result of increased embedded generation and demand reductions leading to a lightly loaded transmission system producing excess reactive power. This is a localised issue but NGESO reports this is seen in all regions.

In addition to this, there is a need to be able to provide reactive power and vary the amount either provided or absorbed for various reasons.

An HVDC link will be very capable at providing reactive power services. These can be provided at both ends of the link by the converters. The equivalent devices to provide a reactive power capability similar to the HVDC converters, where an HVDC link is not present, are such as an SVC, STATCOM and similar devices.

3.3 Voltage support

The provision of reactive power is also important in providing the various voltage support services that NGESO requires. This is similarly a localised issue, but with similar trends to reactive power issues across the regions of the GB transmission system.

As with reactive power provision, an HVDC link will be very capable of providing voltage support services at both ends of the link. The equivalent devices to provide voltage support where an HVDC link is not present are also similar.

For both reactive power and voltage support it should be noted that the type of requirements will dictate the type of device. As an HVDC converter is very flexible and dynamic, a suitable equivalent would be a STATCOM or similar power electronics device, but not fixed capacitors and reactors.

3.4 Power flow control (quadrature booster function)

An HVDC link can control how much power flows through it and hence how much must flow through other circuits which may be in parallel. This offers an operational benefit similar to a quadrature booster in an AC network, something also noted during the Project TransmiT and CMP213 consultation responses. A quadrature booster would provide an equivalent capability on an AC system.

A quadrature booster is a device typically constructed from two transformers, though some versions can be constructed using only one transformer. They have been in use on the GB transmission system for many decades and their behaviour and characteristics are well understood. A quadrature booster acts to control the transfer of power along parallel routes in the transmission system and can therefore control power flows and other system characteristics beyond what would otherwise be possible in an AC system.

The principle of operation is that the quad booster adds an out of phase voltage, of controllable magnitude, to the prevailing voltage of the circuit and thereby causes a controllable shift in the phase angle of the resultant voltage. It is this phase angle which determines the transfer of power along the circuit.

3.5 Black start

Black start service provision has traditionally been provided by large synchronous generators which are flexible enough to provide both balancing and frequency response, and, reactive power and voltage support. Black start involves bringing the system back up after a blackout event. VSC HVDC technology can provide black start capability at either end, provided the other end is up and running and can source real power as required.

In recent years, black start provision has been an issue and service provision costs have been very high. Black start is also a significant issue in Scotland given the lack of plant capable of offering the service.

There is no readily available economic equivalent device to provide black start at present and this capability would normally be purchased from (large synchronous) generators. NGENSO is however looking at other types of service provider as the availability of suitable large synchronous generators has waned over recent times.

4 Quantifying the costs

4.1 Introduction

This section examines the costs associated with the additional functionality and hence the costs that should be removed from the generator local circuit charges associated with an HVDC link.

Whilst the general method used can be applied to any case, it is easier to understand the method, order of costs and the resultant generator local circuit charge reduction by way of an example.

4.2 Example HVDC link

For the purposes of this note, an example HVDC link based on the current Western Isles proposal is used. Costs used are assumed and approximate and are broadly reflective of proposals for both Shetland [9, 10] and the Western Isles [11, 12].

The Western Isles example considers a 600MW HVDC VSC link at a total cost of £700 million assumed to be broken down as follows.

- HVDC Converters £300 million
- HVDC cable circuit £300 million
- HVAC substation assets (switchgear, transformers, etc) £100 million

The overall HVDC converter and cable costs are entered into the local circuit TNUoS calculation as per the current CUSC methodology. This means that £600 million is entered into the local circuit TNUoS calculation giving a local circuit TNUoS charge to the generators of £76 per kW per annum.

It should be noted that non-asset specific costs such as development and consenting costs, insurance and project management are likely to be included in the above figures. These costs are normally allocated pro-rata over the HVDC and HVAC assets as per common practice and as is required by the CUSC.

The following estimates of cost for equivalent plant to provide the additional functionality do not allow for non-asset specific costs (e.g. development costs). This should be taken into account as these costs are often significant. As the non-asset specific costs in the example used above are not known, it is not possible to account for them in this example. Therefore, the cost reductions shown in this note will not fully reflect the costs that should be removed and will be less than if the non-asset specific costs were known and included.

4.3 Net Present Value

For cases such as Black Start where an annual value is calculated, this has been converted to a Net Present Value (NPV) using an 8% discount rate. This has been done to provide a ballpark NPV for the purposes of deduction from the HVDC converter costs. This financial treatment should be revised in line with appropriate practice of NGENSO who is the beneficiary.

4.4 Example cases

Two example cases are used based on the costs and technical capability of the proposed Western Isles HVDC link.

- Case 1. The Western Isles link connects the Scottish mainland (at Beauly) to the Western Isles as proposed. At Beauly the HVDC link is connected to the main 400kV transmission system. On the Western Isles, the HVDC link is connected to the Western Isles 132kV system and this system is not run in parallel with the existing Western Isles link.
- Case 2. An HVDC link with the same costs and technical capability of the proposed Western Isles link is used to connect two mainland regions. The link remains a local circuit however for relevant generators.

Case 1 is examined to understand how the proposed WACM 3 method will apply to the actual proposed Western Isles HVDC link and how this result may be similar for other island connections.

Case 2 is examined to understand how the proposed WACM 3 method may apply to other cases which are not island connections.

No other cases are currently foreseen.

4.5 Equivalent costs

4.5.1 Reactive power and voltage control

To provide the equivalent cost for reactive power and voltage control, the below examines the cost of a STATCOM or similar device. This device (or similar) can provide both functions and is reflective of the capability of the HVDC converter(s).

The two cases are considered as follows.

- Case 1. It is assumed that only the Beaulieu end (mainland Scotland) utilises the capability of the converters as the Western Isles grid is relatively small. This means a dynamic reactive power and voltage control capability at Beaulieu of up to 600MVAR. This case is probably most representative of the Western Isles HVDC link, albeit some capability is likely to be used on the Western Isles.
- Case 2. It is assumed that each end of the HVDC link can provide this capability up to the rating of the link and independently of the other end. This means a dynamic reactive power and voltage control capability at either end of up to 600MVAR.

The cost for an equivalent 600MVAR device is estimated at around £90 million to £110 million depending on the type and specification of the device(s). An average value of £100 million is used. This excludes transformers and switchgear to take the device up to transmission voltage and hence the cost estimate can be more or less directly compared to an HVDC converter cost (one only) at £150 million.

It should be noted that the above calculation does not take utilisation into account. The device of 600MVAR capability is there for use and may at times be operated at 600MVAR whilst at other times less than this, as suits the needs of the transmission system.

For reference purposes, the interconnecting switchgear, transformers and associated other plant to connect from a medium voltage up to transmission voltage are estimated at £20 million to £55 million depending on the transmission voltage, e.g. 132kV, 275kV or 400kV, and the exact specification of the plant. This plant cost is assumed to not be included as it is akin to the AC substation plant excluded from the HVDC local circuit calculation under the current version of the CUSC.

- Case 1. The equivalent costs are £100 million.
- Case 2. The assumed costs are £200 million.

4.5.2 Reactive power and voltage control (alternative method)

An alternative valuation method is to look at the value of reactive power rather than the cost of the equivalent device to provide it. The value of reactive power provision is given in the CUSC. At time of writing in July 2019, the price for reactive power was set at £2.77 per MVARh by NGENSO [13]. It should be noted that this value does not include the value of any voltage control services (contracts) or similar and is the plain mandated price for reactive power. This value is also relatively low for a monthly value over the last two years with most months over £3 per MVARh and some over £3.5 per MVARh. Over the last ten years this value is still quite modest with many periods where prices have been higher. Furthermore, this value does not include any enhanced payments for operation outside of the 0.95-0.85 range, which the HVDC converters will be capable of.

To estimate the value of the reactive power provision annually, it is necessary to understand utilisation. It is assumed that a 600MVAR device sees a 50% utilisation. This means that the assumed 600MVAR capability averages in use at 300MVAR. This gives an annual value of £7.28 million per converter.

Converting the annual value to an NPV gives around £87 million over 40 years for the value of reactive power from the HVDC link. This is of comparable magnitude to the £100 million estimated device cost albeit slightly less.

This reactive power value is however quite sensitive to actual utilisation and financial treatment and as discussed above is a conservative (low) estimate. Reducing the 8% discount rate quickly increases this value over £100 million.

Overall, the device cost is an easier and more robust method and, given the comparability of the two methods, the device cost basis is to be recommended.

4.5.3 Power flow control (quadrature booster function)

To provide the equivalent cost for power flow control, the cost of a quadrature booster is examined below. As the HVDC link cannot perform this function independently at each end, only one quadrature booster would be required to provide the equivalent function of the whole HVDC link. The two cases are as follows.

- Case 1. It is understood that the Western Isles HVDC link will not be run in parallel with the existing AC system. Therefore, the value of this wider benefit is assumed to be zero for the Western Isles.
- Case 2. Taking the example HVDC link, XE estimates the cost of a quadrature booster, suitable for the control of 600MVA, at around £5 million to £10 million depending on the transmission voltage, e.g. 132kV, 275kV or 400kV and exact specification of plant. A value of £7.5 million is thus used as an average.

As a quadrature booster interfaces directly to the transmission system circuit, it is difficult to separate out costs of the plant equivalent to an HVDC converter from the transformers and switchgear which are an integral part of the quadrature booster.

4.5.4 Black start

During 2017/18, NGENSO incurred total costs of £57.7 million for the provision of Black Start [14] across fifteen Black Start Units [15] [16] [17]. Therefore, the average expenditure during 2017/18 was approximately £3.8 million per Black Start Unit. The overall size/capability of these individual units cannot be readily confirmed through publicly available information.

Based on very high-level analysis, a 600MW HVDC link could provide an annual network value of at least £1 million to £4 million based on NGENSO's approximate spend on the current fleet of Black Start units if treated as a unit. However, as seen in recent years, the increasing scarcity of Black Start units could increase this system value and cost significantly.

An alternative method to understand the value of Black Start is to pro-rata the MW that can be Black Started against the total GB MW. For the purposes of this note, peak demand is used, although average might be a better measure.

- Case 1. In the case of the Western Isles, it is assumed the HVDC link would only be used to Black Start the Western Isles and not the mainland. Therefore, the HVDC link can only Black Start a maximum demand of around 30MW, which can be compared to the spend of £57.7 million against a peak GB demand of 57GW. The value is significantly reduced to the order of £30k annually.
- Case 2. Using the same approach but assuming the HVDC link can Black Start up to 600MW as it connects mainland to mainland, gives a value around £607k annually. It is possible to argue that this value could apply at both ends. For the purposes of this note, this is not assumed.

Assuming the average annual values above and a 40 year lifetime for the HVDC link gives a rough net present value as follows.

- Case 1. £0.36 million.
- Case 2. £7.2 million.

A more complete financial analysis is beyond the scope of this paper and an appropriate financial method and variables for this should ideally be provided by National Grid Electricity System Operator.

5 Cost deduction impact on TNUoS

5.1 Introduction

The cost deductions calculated for the above two cases can be added together for each case and deducted from the total entered into the generator local circuit TNUoS calculation as presented below.

5.2 Case 1 - Western Isles example

Table 5-1 below sets out the approximate costs of the Western Isles HVDC link and resultant generator local circuit TNUoS. It then shows the order of capital cost reduction due to the four functions (reactive power and voltage control are treated as one) and the resultant generator local circuit TNUoS reduction compared to the base case (Western Isles HVDC link at £76/kW/annum). The final column looks at the impact on cost and generator local circuit TNUoS with all four functions taken together.

Item	Costs, £ million				
	Western Isles HVDC link	Reactive power & voltage control	Quadrature booster	Black Start	All 4 functions
Equivalent plant (debit)	-	(100)	(0)	(0.4)	(100.4)
HVDC converters	300	300	300	300	300
HVDC cables	300	300	300	300	300
HVAC assets	100	100	100	100	100
Total for TNUoS	600	500	600	599.6	499.6
TNUoS, £/kW/annum	76	64	76	76	64

Table 5-1: Summary of costs and generator local circuit TNUoS tariffs

For the Western Isles it can be seen that only the deductions for the reactive power and voltage control capability at Beaulieu have a material impact. These reduce the costs entered into the generator local circuit calculation by £100 million resulting in a TNUoS reduction from £76 to £64/kW/annum reflecting the value of the HVDC link to the wider system. For reference purposes this is about 33% of the HVDC converter costs in this example.

5.3 Case 2 – Mainland to mainland link

Table 5-2 below sets out the approximate costs of the mainland to mainland example HVDC link, the order of capital cost reduction due to the four functions (reactive power and voltage control are treated as one) and the resultant generator local circuit TNUoS figures (similar to the presentation of Case 1).

Item	Costs, £ million				
	HVDC links	Reactive power & voltage control	Quadrature booster	Black Start	All 4 functions
Equivalent plant (debit)	-	(200)	(7.5)	(7.2)	(214.7)
HVDC converters	300	300	300	300	300
HVDC cables	300	300	300	300	300
HVAC assets	100	100	100	100	100
Total for TNUoS	600	400	592.5	592.8	385.3
TNUoS, £/kW/annum	76	51	75	75	49

Table 5-2: Summary of costs and generator local circuit TNUoS tariffs

For the mainland to mainland case it can be seen that the deductions for the reactive power and voltage control capability are again dominant but that the other functions (Quadrature boost and Black Start) also have a small impact. Overall, these reduce the costs entered into the generator local circuit calculation by nearly £215 million resulting in a TNUoS reduction from £76 to £49/kW/annum reflecting the value of the HVDC link to the wider system. For reference purposes this is about 72% of the HVDC converter costs in this example.

6 Summary

6.1 General

This short note has briefly outlined four additional functions that are provided with a VSC HVDC link in the transmission system and that are not necessarily required for generators using the link and effectively paying for it via generator local circuit TNUoS.

These additional functions have costs associated with them and thus, these costs should be deducted from the costs entered into the generator local circuit TNUoS calculation. This will provide a more cost reflective charge to the generators and better reflect the wider system costs and benefits where such equivalent plant cost is normally socialised or recovered through other means.

6.2 Additional functions

The additional functions examined herein are as follows.

- Reactive power provision
- Voltage control
- Power control (quadrature booster function)
- Black Start

There are also other functions that the VSC HVDC link can provide and could be examined also. These are briefly highlighted in Appendix A.

6.3 Equivalent plant or service costs

For each function, it is proposed that the cost of the equivalent plant is established and deducted from the relevant costs of the HVDC link that are entered into the generator local circuit TNUoS calculation. For the case of reactive power and voltage control, it is proposed to cost SVC, STATCOM or similar plant. For the case of power control, it is proposed to cost a quadrature booster. For the case of black start, there is no equivalent plant as such and the costs of providing or procuring the service needs to be used.

6.4 Cases examined - results

Two cases have been examined in this note, both based off a 600MW, £700 million HVDC link. The two cases are the Western Isles HVDC link (as proposed), and a mainland to mainland HVDC link.

For the Western Isles it has been calculated that approximately £100 million should be deducted. This is based on the value of reactive power and voltage control at Beaulieu. This is 33% of the HVDC converter costs and reduces the generator local circuit TNUoS from £76 to £64/kW/annum.

For the mainland to mainland link, most of the equivalent cost (£200 million) is again due to reactive power and voltage control but this time at both ends. Power control (quadrature boost) and Black Start add a further small cost (just under £15 million). This totals 72% of the HVDC converter costs and reduces generator local circuit TNUoS from £76 to £49/kW/annum.

7 References

- [1] Ofgem, "Electricity transmission charging: assessment of options for change", 20 December 2011.
- [2] Ofgem, "Electricity transmission charging arrangements: Significant Code Review conclusions", 04 May 2012.
- [3] National Grid, "Stage 02: Workgroup Consultation - CMP213 Project TransmiT TNUoS Developments", 07 December 2012.
- [4] National Grid, "Stage 04: Code Administrator Consultation - Volume 1 - CMP213 Project TransmiT TNUoS Developments", 10 April 2013.
- [5] National Grid, "Stage 06: Final CUSC Modification Report - Volume 2 - CMP213 Project TransmiT TNUoS Developments - Annexes", 14 June 2013.
- [6] Ofgem, "Project TransmiT: Impact Assessment of industry's proposals (CMP213) to change the electricity transmission charging methodology", 01 August 2013.
- [7] Ofgem, "Project TransmiT: Further consultation on proposals to change the electricity transmission charging methodology", 25 April 2014.
- [8] Ofgem, "Project TransmiT: Decision on proposals to change the electricity transmission charging methodology", 25 July 2014.
- [9] Scottish and Southern Energy Power Distribution plc, "Shetland HVDC Link Consultation", August 2016.
- [10] P. Wheelhouse, "Renewables", in *Scottish Parliament*, Edinburgh, December 2016.
- [11] Scottish & Southern Electricity Network, "Western Isles HVDC Link Consultation", 2017.
- [12] Subsea World News, "Western Isles HVDC Link Costs Rise (UK)", Subsea World News, 05 December 2012. [Online]. Available: subseaworldnews.com. [Accessed 04 December 2018].
- [13] National Grid Electricity System Operator plc, "CUSC - Section 14 - Charging Methodologies", CUSC v1.22, 23 August 2018.
- [14] National Grid ESO, "Black Start Allowed Revenue", April 2018.
- [15] National Grid, "Monthly Balancing Services 2017/18", January 2018.
- [16] National Grid, "Monthly Balancing Services 2017/18", February 2018.
- [17] National Grid, "Monthly Balancing Services 2017/18", March 2018.
- [18] National Grid, "System Operability Framework", November 2016.
- [19] Baringa, "Scottish Islands Renewable Project", 14 May 2013.

8 Appendix A - Other benefits of HVDC

8.1 General

This section briefly highlights other potential wider system benefits of HVDC.

8.2 Other wider system benefits of HVDC

8.2.1 Short circuit level

A VSC HVDC link can work with low network fault levels, such as on the Scottish islands. It also offers some uplift in fault level, albeit limited to about the rating of the link.

8.2.2 Increased fault level- power quality and stability

Low fault levels result in many issues such as power quality, protection difficulties and stability problems. National Grid Electricity System Operator has identified a drop-in network fault levels as a problem on the main transmission system [18].

The existing fault levels on the Scottish islands are already very low as a result of electrical remoteness or high circuit impedance back to the main transmission system on the mainland. The addition of the proposed HVDC link will increase fault levels and the additional generation it facilitates will also increase fault levels. The level of increase will also depend in part on how the new HVDC link and existing system are configured.

8.2.3 Balancing and frequency response

In addition to improving security of supply, the HVDC link can provide a balancing and frequency response function to isolated ends. The HVDC link itself cannot provide real power and so this assumes it can source the necessary variable real power from one end, so as to provide the service at the other end. For the Scottish islands, the implication is that this is provided by mainland generators.

8.2.4 Socio-economic impacts

The socio-economic uplift to regions connected via HVDC links or other has been noted in the past. This issue was also addressed in 2013 through an independent report [19]. The report concluded that development of renewable generation on the Scottish islands could have significant benefits to both the local island economy, the rest of Scotland and elsewhere in the UK. There would also be facilitation of further marine renewables development to the benefit of UK businesses involved in the sector.

The report further concluded the development of island renewable generation would bring carbon and fuel savings. For the Western Isles and Shetland this would be facilitated by the VSC HVDC links.

The report also concluded that the island renewable generation and associated transmission links could provide further benefits related to local security of supply, whilst the diversity benefits of developing renewables on the islands (especially marine) could reduce the overall cost of intermittency on the GB system.

8.2.5 Promotion of new renewables and sustainability

Currently, both installed HVDC links primarily facilitate further deployment of renewable energy in Scotland. This would appear to be similar for the currently proposed HVDC links and a number of possible future links. This meets the political sustainability agenda for renewable energy.

8.2.6 Reduction in future HVDC costs through learning

During Project TransmiT it was considered that there would be some wider benefit to install HVDC links now in terms of learning and future cost reductions. This is based on the premise that HVDC links will become much more prevalent in future.

8.2.7 Power oscillation damping

The VSC HVDC link can provide power system stabilisation and in particular be used to damp down power oscillations. This is a concern of National Grid Electricity System Operator and requirements to consider this and act against it have been introduced in recent years.

8.2.8 Power quality (flicker, unbalance and harmonics)

The fast-reactive capability of the VSC HVDC link can be used to reduce voltage flicker and reduce or eliminate certain voltage harmonics and voltage unbalance. This can provide a direct improvement in power quality.

8.2.9 System inertia

While power electronic converters do not themselves provide any inertia, they can be programmed to provide synthetic inertia. Reducing inertia is a problem on the transmission system [18] and results in various issues such as reduced stability.

9 Appendix B - Acronyms

Acronym	Definition
CMP	CUSC Modification Proposal
CUSC	Connection and Use of System Code
FACTS	Flexible Alternating Current Transmission Systems
GB	Great Britain
HVAC	High Voltage Alternating Current
HVDC	High Voltage Direct Current
kV	Kilovolt
MVAr	Megavolt Ampere reactive
MW	Megawatt
Ofgem	Office of Gas and Electricity Markets
Quadrature booster	Phase Angle Regulating Transformer
STATCOM	Static Synchronous Compensator
SVC	Static Volt Ampere Reactive Compensator
TNUoS	Transmission Network Use of System (charges)
VSC	Voltage Source Converter
WACM	Workgroup Alternative CUSC Modification proposal

23 Annex 10: Xero Energy Position Paper - Wider System Benefits of HVDC – CIGRE



Xero Energy Limited
60 Elliot Street
Glasgow G3 8DZ
United Kingdom
Tel: +44 (0)141 221 8556
www.xeroenergy.co.uk
Reg. SC313697 in Scotland

BRIEFING NOTE

PROJECT: CMP 303 support
SUBJECT: Wider System Benefits of HVDC – CIGRE
CLIENT: Not applicable
REFERENCE: BRN 1234/028/003A
CLIENT REFERENCE: Not applicable

Document History

V	AUTH	VERF	APPR	DATE	NOTES
A	NCS	JSF, MK	NCS	12/09/2019	First issue

Notes

This document and any accompanying documents are to be distributed to members within the named client organisation only and are not to be distributed to other third parties or the public without express written consent from Xero Energy Limited. Xero Energy Limited does not accept responsibility for the application or use made of information or advice supplied. Such responsibility remains with the client.

1 Introduction

This report has been drafted to support work that has been undertaken by the CMP303 working group. This note presents a review of a number of CIGRE papers on HVDC systems with a view to understanding and quantifying the wider benefits that arise from the grid services provided by HVDC systems.

CMP303 has proposed that the current CUSC method of charging generators a generator local circuit TNUoS charge for HVDC systems is not fully cost reflective if the HVDC systems contain benefits for the wider system which are not required by the generators, i.e. the generators should not be paying for functionality they do not require. Therefore, the generator local circuit TNUoS charge should be reduced, and, this reduction should reflect the financial value of the wider benefits which are not used or needed by the generators.

There are several wider benefits provided by HVDC systems to a grid beyond those needed or utilised by generators. These benefits and services have been previously outlined in a discussion note provided to the CMP303 working group [1]. In this previous note, the following four key wider benefits were identified and a method presented to quantify the benefits by costing the equivalent plant needed to provide them.

- Reactive power provision
- Voltage control
- Power control
- Black start capability

Within this report, the CIGRE literature on this topic is reviewed and the information relevant to the wider benefits of HVDC links is summarised. Based on the CIGRE literature, the estimated costs related to HVDC services are then presented and discussed.

It should be noted that a number of CIGRE publications were cited as evidence of HVDC wider benefits during an earlier CUSC process, CMP213, and this has been referenced again by one proposal in the CMP303 working group. These CIGRE publications are reviewed herein along with any additional CIGRE papers.

2 Literature review

2.1 Introduction

This section summarises the findings of review of CIGRÉ literature on this topic. A general search of CIGRE papers was undertaken and three reports were identified to form this literature review as below. These are the reports that were identified during CMP213 [2] [3], plus an additional report identified separately [4].

- CIGRÉ TB 186 - Economic assessment of HVDC Links – June 2001 [2].
- CIGRÉ TB 388 - Impact of HVDC lines on the economics of HVDC projects – August 2009 [3].
- CIGRÉ TB 492 - Voltage source converter (VSC) HVDC for Power transmission - Economic aspects and comparison with other AC and DC technologies – April 2012 [4].

These reports look at a range of issues, and in part, benefits and costs which are applicable to HVDC systems. These reports were produced between 2001 to 2012. Because of this the information provided may not be as up to date as it would ideally be and this should be born in mind in regard any cost calculations and conclusions.

2.2 CIGRÉ TB 186 - Economic assessment of HVDC Links

2.2.1 Overview

CIGRÉ TB 186 focuses on the capital and operational costs of HVDC systems as well as the methodology for calculating these. It does not however focus on the assessment of the wider system benefits / services. It states that the technical benefits an HVDC system brings should be included in economic assessments.

The report discusses the wider benefits of HVDC links but does not provide any information on the level of cost savings or the equipment the benefits could replace. This is highlighted particularly in section 5.1.1 in the following quotes [2]:

- *“HVDC can feed (or reduce) active power into the disturbed system to control the frequency much faster than a normally controlled generator. If the feeding AC system is strong enough the DC link can, within its rating, control the frequency in the receiving system. A prerequisite for this kind of system support is only the appropriate mode of control.”*
- *“Control features for power modulation with the appropriate phase angle can actively introduce damping torque. In general, this valuable feature of an HVDC link is inherent and requires no significant extra costs”*
- *“A DC link can also be used for voltage control. The convertor absorbs reactive power depending on the control angle, which normally will be compensated by filters and/or capacitor banks.”*

No values are given or suggested for what the significant extra costs may be. This paper only serves to confirm, qualitatively, the assumption that there are wider benefits of HVDC systems.

2.3 CIGRÉ TB 388 - Impact of HVDC lines on the economics of HVDC projects

2.3.1 Overview

This report focuses on the cost of HVDC lines rather than any wider benefits and has little discussion on the issues relevant to this report. It does, however, present a breakdown of the capital cost of an HVDC substation (HVDC and HVAC portions).

2.3.2 HVDC substation cost breakdown

The breakdown of the capital cost of an HVDC substation is in table 5.4 of CIGRE TB 388. This is reproduced in Table 2-1 below.

Standard thyristor bipole with two terminals	Standard Bipole [%]	HVDC Equipment [%]
Valve Group	22	22
Converter Transformer	22	
DC Switchyard and filter	6	6
AC Switchyard and filter	9	
Control, protection, communication	8	
Civil, mechanics, works	13.5	
Auxiliary Power	2.5	
Project engineering, administration	17	
Total 100	100	

Table 2-1: Cost division showing % capital cost for HVDC [3]

This shows approximately a 47% HVDC and 53% HVAC cost split for the capital costs of the HVAC and HVDC parts of a substation, with cost such as project engineering pro-rata allocated across the HVAC and HVDC plant.

This approximate 50/50 value varies significantly from XE recent experience on projects. This is only a capital cost and does not consider the wider benefits of HVDC systems.

With reference to the GB Connection and Use of System Code, direction is already given on how to apportion substation costs for the purposes of generator local circuit TNUoS charge calculation. In the current version of the CUSC this is captured in Section 14.15.76 and has recently been clarified via CMP301. The current CUSC presents a specific calculation for each substation based on the actual assets and asset values using a common boundary, rather than a generic percentage split approach.

2.4 CIGRÉ TB 492 - Voltage source converter (VSC) HVDC for Power transmission – Economic aspects and comparison with other AC and DC technologies

2.4.1 Overview

Out of the three CIGRÉ reports cited, CIGRÉ TB 492 is the most relevant. It is also the most recent. It compares the advantages of voltage source converter HVDC systems against other types of DC and AC systems. Part of the comparison process involves an economic assessment of the wider benefits of the systems.

The report has a table which shows the relative advantages for value matrix for HVDC systems when used for large system and island interconnections. The table shows that HVDC (VSC type) systems tend to be better suited to provision of the following grid services.

- Damping control
- Voltage control
- Voltage quality
- Black start

2.4.2 Economic values of wider system benefits

CIGRÉ TB 492 provides some information regarding the economic value of additional grid services such as reactive power support and active power control. These are outlined in the following paragraphs and tables.

Reactive power support for voltage control

Table 4.7 from CIGRÉ TB 492 outlines suggested availability and utilisation service payments which are typical for basic and enhanced reactive power support across Europe. A value of 0.3 to 0.5 €/MVar/h for basic reactive power support based on a study of the Italian market is given. This is shown in Table 2-2. The €4.52/MVar/h utilization payment for enhanced reactive power support value is referenced to the reactive power market in Britain, cited from a National Grid study.

Item	Basic reactive power support	Enhanced reactive power support
Power factor	above 0.95 lead & 0.85 lag	below 0.95 lead & 0.85 lag
Availability payment	0.3 .. 0.5 €/MVar/h	0.3 .. 0.5 €/MVar/h
Utilization payment	0	4.52 €/MVar/h

Table 2-2: Reactive power support (from table 4.7 [4])

Power control

Table 4.9 in CIGRÉ TB 492 provides capital costs for the plant required for power flow control in an HVAC system. This function is inherently available in HVDC systems. This is shown in Table 2-3. The values presented are referenced to a report by DENA from 2005. Typical HVAC plant for power control on parallel circuits would be quadrature boosters.

Active power flow control	Additional investment costs for HVAC to achieve	HVDC
Slow successive	12 €/MVA	Inherent
Fast continuous	40 €/MVA	Inherent

Table 2-3: Active power control – equipment costs (from table 4.9 [4])

Black start

An economic value for the provision of black start capability is given in Table 4.11 of CIGRÉ TB 492. Section 4.3.6 states there are a number of possible methods to assess the value of black start capability. The report uses analysis of gross domestic product to give a value of 0.86 k€ per year and MW capacity. It also states that another approach would be the actual contract value for existing black-start capability provisions.

Wider benefit economic value summary

A summary of the economic value of the services and functions identified in CIGRÉ TB 492 is shown in Table 2-4. Included are the wider benefits discussed above (reactive power – voltage control, power control and black start) plus a number of other wider benefits cited by the CIGRÉ work.

Service / function	Economic value (CIGRÉ TB 492 [4])
Fast active power flow control	40 €/MVA
Basic reactive power availability	0.3 to 0.5 €/MVar/h
Enhanced reactive power availability and utilisation	0.3 to 0.5 €/MVar/h + 4.52 €/MVar/h
Transient stability improvement	Case dependant (e.g. 15% more NTC)
Damping control	-
Black-start / Island supply	0.86 k€ per year and MW capacity
Environmental impact	Varies from case to case – reported 6 to 10% of transmission investments in one example
System loss production	1..2% of overall system losses

Table 2-4: Economic evaluation of beneficial functions (from Table 4.11 in [4])

Net Present Value

CIGRÉ TB 492 [4] section 4.3 also outlines a method for the calculation of the wider system benefits of an HVDC system using Net Present Value (NPV) analysis to construct the cost value of HVDC services.

3 HVDC wider system benefits

3.1 Introduction

This section estimates the value of the wider system benefits (additional grid services) provided by HVDC to provide an estimate of the overall value of the HVDC wider system benefits.

3.2 Method

The following method has been used to assess the potential value of HVDC wider system benefits.

1. Relevant services and values are identified from CIGRÉ TB 492 above.
2. These are then used to calculate an annual value or equivalent equipment capital cost for each service.
3. The calculated annual values are then converted to an NPV to understand the overall and present value of the service to which any equivalent equipment capital costs are added.

For the NPV analysis, a discount rate of 8% has been used. This value is taken from the cash flow analysis example in section 5.4.4 of CIGRÉ TB 492 [4]. The NPV for a 40-year project has been calculated to reflect typical asset lifetimes.

Whilst the general method used could be applied to any case, it is easiest to understand the order of costs and the resultant generator local circuit charge reduction by way of an example. For the purposes of this note, and to allow comparison to [1], the same examples are used, outlined below in Section 3.3.

3.3 Example HVDC link

3.3.1 Capital costs

Costs used are assumed and approximate and are based on proposals for Shetland [5] [6] and the Western Isles [7] [8]. The example considers a 600MW HVDC VSC link at a total cost of £700 million assumed to be broken down as follows.

- HVDC converters £300 million
- HVDC cable circuit £300 million
- HVAC substation assets (switchgear, transformers, etc) £100 million

The HVDC converter and cable costs are entered into the local circuit TNUoS calculation as per the current CUSC methodology. This means that £600 million is entered into the local circuit TNUoS calculation giving a local circuit TNUoS charge to the generators of £76 per kW per annum.

It should be noted that non-asset specific costs such as development and consenting costs, insurance and project management are likely to be included in the above figures. These costs are normally allocated pro-rata over the HVDC and HVAC assets as per common practice.

Similar to [9], The following estimates of cost for equivalent plant to provide the additional functionality do not allow for non-asset specific costs (e.g. development costs). This should be taken into account as these costs are often significant. As the non-asset specific costs in the example used above are not known, it is not possible to account for them in this example. Therefore, the cost reductions shown in this note will not fully reflect the costs that should be removed and will be less than if the non-asset specific costs were known and included.

3.3.2 Example cases

Similar to [9], two example cases are used based on the costs and technical capability of the proposed Western Isles HVDC link.

- Case 1. The Western Isles link connects the Scottish mainland (at Beaully) to the Western Isles as proposed. At Beaully the HVDC link is connected to the main 400kV transmission system. On the Western Isles, the HVDC link is connected to the Western Isles 132kV system and this system is not run in parallel with the existing Western Isles link.
- Case 2. An HVDC link with the same costs and technical capability of the proposed Western Isles link is used to connect two mainland regions. The link remains a local circuit however for relevant generators.

Case 1 is examined to understand how the method will apply to the actual proposed Western Isles HVDC link and how this result may be similar for other island connections. Case 2 is examined to understand how the method may apply to other cases which are not island connections.

No other cases are currently foreseen.

3.4 Equivalent costs

3.4.1 Power control capability

It has been assumed that the 600MW HVDC link can provide up to a 600MW power control capability. This is similar to [1]. The calculation for fast active power support gives a value of €24,000,000 based on a 600MW capability. This is an equipment cost rather than a per annum value so is not related to the time it is being used like the other three values. If there is no parallel AC links, then this value is zero.

- Case 1. It is understood that the Western Isles HVDC link and existing AC link will not be run in parallel and therefore the value of the power control capability can be set to zero.
- Case 2. It is assumed that the full link capability can be used and the value is thus €24,000,000.

3.4.2 Reactive capability

The quoted CIGRE values given above were used to calculate the value per annum for the example 600MW HVDC system with reactive power capability of up to 600MVAR at each end. According to CIGRÉ TB 492 [4], the reactive capability depends on the overall MVA rating of the HVDC system, the amount of real power being transmitted and the voltage. For the example used, the capability available, and hence the average utilised capacity, has been assumed to be the average of the 40% to 60% range (240MVAR to 360MVAR) quoted for an example in [4], i.e. 50% or 300MVAR.

A value of €0.4/MVAR/h has been used as the average of the range 0.3-0.5 quoted by CIGRÉ. The calculations were also run with 5% enhanced reactive power utilization (operation below 0.95 lead & 0.85 lag) to assess the potential impact of this payment. Review of National Grid Electricity System Operator's reactive power market reports shows that enhanced reactive power services seem to seldomly be used [9], hence the 5% assumption.

- Case 1. For the Western Isles end HVDC converter it has been assumed the capability is hardly used and accordingly has been set to zero value. For the mainland end HVDC converter a 300MVAR use has been assumed. This gives an annual value of €1646k, or an NPV of €19.6 million.
- Case 2. For a mainland to mainland HVDC link it has been assumed that 300MVAR is used on average at each end. This gives €3293k annually or an NPV of €39.2 million.

3.4.3 Black start capability

The HVDC link is assumed to be capable of Black Starting up to 600MW as required and the value is €0.86k per year and MW capacity as per CIGRÉ TB 492 [4].

- Case 1. It has been assumed that the 600MW HVDC link will be used to Black start up to 30MW of demand on the Western Isles, this figure being assumed representative of the approximate maximum demand, as used also in [1]. This gives an annual value of €25.8k and an NPV of €308k.
- Case 2. The value of black start has been taken according to the full link rating of 600MW on the basis that the HVDC link is linking two mainland areas. This gives an annual value of €516k and an NPV of €6.2 million.

3.5 Cost summary

The total cost (or value) in each case is as follows.

- Case 1. €20 million, almost entirely built up from the value of the mainland end reactive power and voltage control. This is around 6% of the HVDC converter cost, using a €1.15 to £1 exchange rate.
- Case 2. €69 million, across all four services. This is around 20% of the HVDC converter cost, using a €1.15 to £1 exchange rate.

4 Conclusions

4.1 General

This note has briefly reviewed a number of CIGRE papers and used CIGRÉ TB 492 [4] to derive the value of the wider system benefits of an example HVDC link representing two cases.

- Case 1. A 600MW, £700 million HVDC link from Beaulieu on mainland Scotland to the Western Isles, as proposed.
- Case 2. A 600MW, £700 million HVDC link from one mainland location to another mainland location.

Using assumptions similar to [9], Case 1 yields a value of around €20 million and Case 2, €69 million. Using a €1.15 to £1 exchange rate yields, £17 million and £60 million respectively. These values are around 6% and 20% of the converter costs for Case 1 and Case 2 respectively.

4.2 Comparison to [9]

The above values are significantly less than the 33% and 72% of HVDC converter cost estimated in [9]. This is mainly because CIGRE quotes (basic) reactive power value at €0.4 per MVarh and in the GB market the (basic) value used in [11] is £2.77 per MVarh, almost ten times the value. The study [9] also used the estimated capital cost of a 600MVar equivalent reactive power and voltage control device at £100 million whereas CIGRE has used an operational service value (at the lower rate as noted).

The value of power control is €24 million versus £7.5 million [9], and Black Start at €860 per MW per annum versus £1012 per MW per annum [9], values which are less significant and closer in terms of magnitude. It should be noted the €24 million for a quadrature booster may include switchgear and other items which are excluded from the £7.5 million estimate in [9].

4.3 4.3 other points of note

Both studies have tended to err on the side of conservatism and hence the cost estimates will tend to the lower end of the range on this basis.

The CIGRE work is also from 2012 meaning the values it uses, from the wider European markets, are around seven to eight years out of date and may now be higher if for example inflation is considered.

5 References

- [1] Xero Energy Limited, "WACM 3 Wider system benefits of HVDC", Breifing Note, BRN 1234/028/001C, 04 February 2019.
- [2] CIGRÉ, "Economic Assessment of HVDC Links", Technical Brochure 186, 2001.
- [3] CIGRÉ, "Impacts of HVDC Lines on the Economics of HVDC Projects", Technical Brochure 388, 2009.
- [4] CIGRÉ, "Voltage source converter (VSC) HVDC for Power transmission - Economic aspects and comparison with other AC and DC technologies", Technical Brochure 492, 2012.
- [5] S. a. S. E. P. D. plc, "hetland HVDC Link Consultation", August 2016.
- [6] P.Wheelhouse, "'Renewables", in Scottish Parliament, Edinburgh", December 2016.
- [7] S. & S. E. Network, "Western Isles HVDC Link Consultation", 2017.
- [8] S. W. News, "Western Isles HVDC Link Costs Rise (UK", Subsea World News, 05 December 2012. [Online]. Available: subseaworldnews.com. [Accessed 04 December 2018].
- [9] Xero Energy Limited, "WACM 3 Wider system benefits of HVDC", Briefing Note, BRN 1234_028_001D, 04 September 2019.
- [10] National Grid Electricity System Operator, "Enhanced reactive power service (ERPS)", [Online]. Available: <https://www.nationalgrideso.com/balancing-services/reactive-power-services/enhanced-reactive-power-service-erps?market-information>. [Accessed 14 March 2019].
- [11] National Grid Electricity System Operator plc, "Obligatory Reactive Power Services", July 2019.

24 Annex 11: Further ESO Analysis: WACM Scenarios

<https://www.nationalgrideso.com/document/153116/download>

Further analysis on WACM Scenarios can be found via the above link to the National Grid ESO website.

25 Annex 12: Ofgem Send Back Letter



Making a positive difference
for energy consumers

Trisha McAuley
CUSC Panel Chair
c/o National Grid Electricity
System Operator
Faraday House
Warwick Technology Park
Gallows Hill
Warwick
CV34 6DA

Direct Dial: 020 3263 9721
Email: tim.aldridge@ofgem.gov.uk
cc. cusc.team@nationalgrid.com

Date: 11 June 2019

Dear Trisha,

Authority decision to direct that the modification report on Connection and Use of System Code (CUSC) CMP303: 'Improving local circuit charge cost-reflectivity' be revised and resubmitted

EDF Energy raised CMP303 for consideration by the CUSC Panel on 27 July 2018. The Panel decided to send CMP303 to a Workgroup to be developed and assessed against the CUSC Applicable Objectives. On 18 April 2019, the CUSC Panel submitted a Final Modification Report (FMR) for CMP303 to us.

The Proposer raised CMP303 'to make part of the TNUoS charge more cost-reflective through removal of additional costs from local circuit expansion factors that are incurred beyond the connected, or to-be-connected, generation developers' need.' The FMR included nine Workgroup Alternative Code Modifications ("WACMs"), in addition to the Original Modification.

We have determined that we cannot properly form an opinion on CMP303 based on the submitted FMR. We therefore direct that the FMR is revised and resubmitted to take into account our concerns expressed below.

1. Concerns

We have identified two principal concerns with the FMR: the Workgroup has not undertaken sufficient analysis, and the legal text is not sufficiently robust.

1.1 Analysis

We have a number of concerns with the analysis provided in the FMR. At various points in the FMR, the Workgroup commits to undertake more detailed analysis. For example:

'In order to fulfil the requirements of this modification, the Workgroup agreed that the costings of mono-directional vs bi-directional transmission links would need to be understood in full.' (p.7)

'The Workgroup endeavoured to understand how tangible and detrimental the current charging baseline error, as perceived by the Proposer, was within the CUSC.' (p.8)

'NGESO made it clear throughout their analysis that these figures are very high level; the Workgroup will need to explore this further following the development of the solution within the Workgroup.' (p.9)

'As this is only initial and very high level analysis, the workgroup will need to consider their solution in detail. Due to the intricacies of the Transport and Tariff Model, the modification will have to be very clear on what calculation will need to take place and also the information provision from the TO and how this fits into the model. This will ensure that the analysis is reflective of the modification's intent.' (p.2 of Annex 4 – NGESO Impact Analysis)

On the basis of the FMR, the Workgroup does not appear to have fully-completed these tasks. Furthermore, the Terms of Reference¹ (ToR) for the Workgroup state (p.2) that it should consider and report on specific issues, including:

- a) Understanding the impacts on wider and local tariffs*
- b) Understanding the impact on generation and demand concerned*
- c) Consideration of the overall benefits of the change v impact on consumers.*

Any such analysis has only been undertaken in a cursory manner and does not provide a robust basis to inform our decision making for CMP303.

In addition, the Panel's consideration of the FMR raised two points that have not been fully explored by the Workgroup.

The first is that some of the WACMs propose, as part of the solution, excluding a proportion of the convertor costs from the expansion factor for HVDC and AC subsea cables. The analysis presented by the Workgroup is inconclusive as to whether or not these WACMs are consistent with our decision on CMP213.² Some Workgroup members have used CMP213 to support these WACMs, while one Panel member cited CMP213 in rejecting these WACMs.

The second concerns a lack of analysis of the extent to which CMP303 would be consistent with respect to historical connections and/or onshore circuits. Some Panel members questioned whether CMP303 would lead to differential treatment of generators, with the potential to undermine competition.

1.2 Legal text

The drafting of the legal text appears not to have been fully-completed, as there are drafting notes in the legal text in the FMR. Some of the legal text in the FMR also shows changes against earlier versions of the modification proposal considered by the Workgroup, rather than the baseline of the existing CUSC text.

More substantively, we have outstanding concerns relating to how legally robust the proposed text will be. In particular, it is not clear from the FMR whether or not existing provisions (e.g. in the System Operator (SO) – Transmission Owner (TO) Code (STC)) would be sufficient for the sharing of relevant costs (of additional functionality) between a TO and National Grid Electricity SO (NGESO). Page 9 of the FMR notes *'that the nature, timing and information of the data flows between the respective TOs and NGESO would need to be clarified if the modification were to be implemented.'*

On a related point, it is not clear that the proposed wording would be robust in practice in terms of the generator agreeing to the incremental costs as proposed by the relevant TO. Such a potential disagreement between the generator and TO may undermine the intent of the modification, which is to identify costs beyond those needed by the generator.

¹ The Workgroup ToR start on page 90 of the FMR.

² CMP213: Project TransMIT TNUoS Developments: <https://www.nationalgrideso.com/codes/connection-and-use-system-code-cusc/modifications/cmp213-project-transmit-tnuos-developments>

Furthermore, 5d of the Workgroup ToR states that the group should '*clarify source and process of information required to determine the cost to be proportioned*'. The legal drafting does not do this.

WACM4 (and its variants) relate to a so-called 'DUoS offset' whereby the costs of additional functionality are levied on distribution rather than transmission customers. Without prejudice to our final decision on this modification or the whole systems principle this is seeking to support, we have not been presented with compelling evidence that the proposed approach for these WACMs is legally robust. We echo the concerns of a number of Panel members that it is unclear that these proposed changes to the CUSC are the appropriate route for giving effect to this proposed mechanism.

2. Additional steps

We therefore direct that additional steps are undertaken by the CUSC Panel to address these concerns. A revised FMR should address the points below.

2.1 Analysis

The revised FMR should include more robust analysis to ensure that the specific issues, 5a-c of the ToR, are addressed. It should clarify where the analysis proposed in the FMR has been undertaken and record the Workgroup's and Panel's conclusions of said analysis. In considering the impacts of the proposal, it should also take into consideration the issues recently raised by CMP317³ and Ofgem's Targeted Charging Review minded-to decision⁴ on setting the Transmission Generation Residual to zero, both of which have the potential to change the impact of CMP303.

Additional analysis should also be undertaken to address the two points of concern raised by Panel members. This analysis should:

- a) present analysis on the extent to which the WACMs relating to a proportion of convertor costs (being considered as additional functionality) are consistent with the conclusions of previous modification CMP213; and
- b) evaluate the proposed modification in terms of the impact on competition with historical and onshore circuits.

2.2 Legal text

The revised FMR should provide assurances that the proposed legal text would be robust in practice, including addressing the ToR requirement 5d. This should include consideration of the need for safeguards to avoid a potential for conflict of interest where the relevant TO and generator are part of the same parent group or where they disagree on what is to be considered as an additional/incremental cost.

We note that a separate proposal has been made by Scottish Hydro Electric Power Distribution in relation to the Scottish Islands which could affect the 'DUoS offset' WACMs. Our latest view on this proposal and further information can be found on our website.⁵

Furthermore, the legal drafting should take into account our approval of CMP301, published alongside this letter, which affects some of the same legal text as is proposed to be amended by this modification.

³ CMP317: Identification and exclusion of Assets Required for Connection when setting Generator Transmission Network Use of System (TNUoS) charges: <https://www.nationalgrideso.com/codes/connection-and-use-system-code-cusc/modifications/identification-and-exclusion-assets>

⁴ <https://www.ofgem.gov.uk/publications-and-updates/targeted-charging-review-minded-decision-and-draft-impact-assessment>

⁵ <https://www.ofgem.gov.uk/publications-and-updates/consultation-shepd-proposal-contribute-proposed-transmission-links-shetland-western-isles-and-orkney>

3. Other issues

Finally, we note that some of the shortcomings with the FMR would appear to be partly as a result of the accelerated timetable for taking forward this proposal. While we acknowledge the desire for certainty in advance of the current Contracts for Difference (CfD) allocation round, we consider the accelerated timetable has in this case served to undermine the robustness of the conclusions of the Workgroup. We also consider that the proposed legal text would not have necessarily removed the uncertainty with respect to network charging that the Proposer was seeking, and that this is just one of a number of other uncertainties to be factored into CfD bids.

After addressing the issues discussed above, and revising the FMR accordingly, the CUSC Panel should re-submit it to us for decision as soon as practicable.

Yours sincerely

Andrew Burgess
Deputy Director, Charging and Access
Duly authorised on behalf of the Authority

26 Annex 13: Second Code Administrator Consultation Responses

CMP303 – Second Code Administrator Consultation - Response pro-forma

Industry parties are invited to respond to this consultation expressing their views and supplying the rationale for those views, particularly in respect of any specific questions detailed below.

Please send your responses by **2 October 2019** to cusc.team@nationalgrid.com. Please note that any responses received after the deadline or sent to a different email address may not receive due consideration by the CUSC Modifications Panel when it makes its final determination.

These responses will be included in the Final CUSC Modification Report which is submitted to the CUSC Modifications Panel.

Respondent:	Paul Mott
Company Name:	EDF Energy
Do you believe that the proposed original or any of the alternatives better facilitate the Applicable CUSC Objectives? Please include your reasoning.	<p>Yes. Regarding (a) (<i>facilitates effective competition...</i>) – the original, and the WACMs except 4, 5, 6 and 7, have the potential to allow relevant generators to compete fairly in the market without being handicapped by paying extra costs unrelated to the export of their power.</p> <p>The concept that underlies WACMs 4, 5, 6 and 7 is being considered separately by Ofgem; it entails a risk of double counting in that consumers might have to pay some costs twice : they may already be paying for some of the cost of the initially-surplus link capacity for a given island, until the link is fully utilised by growth in the connected generation’s total capacity, through demand TNUoS, yet under the new proposal, in addition they make SHEPD’s proposed capital contribution, the calculation of which assumes that they aren’t already funding any of the link. The total contribution could thus be in excess of assumed benefits.</p> <p>Regarding (b) (<i>.....charges which reflect, as far as is reasonably practicable, costs</i>), the original and WACMs allow relevant generators to face a cost-reflective local circuit charge, without paying for extra costs unrelated to the export of their power. WACM4,5,6,7 however are neutral here, as it is not clear if they are workable or relevant.</p> <p>Regarding (c) (<i>...properly takes account of the developments in transmission licensees’ transmission businesses</i>), the original and the variants except 4, 5, 6 and 7 inclusive better meet this, as HVDC island links don’t exist yet, and the original, and others, cover these new links – so that such a development would be properly taken account of in a fair and cost-reflective manner. The original is not limited to HVDC though, and neither is the</p>

	<p>demand pro-rata WACM.</p> <p>(d) Compliance with the Electricity Regulation and (e) Promoting efficiency in the implementation and administration of the CUSC arrangements, have no relevance, so the mod and WACMs are neutral against these two charging objectives.</p> <p>Thus, overall the objectives are better met by the original and all WACMs except 4 to 7 inclusive, which do not better meet the objectives than original, or than baseline.</p>
<p>Do you support the proposed implementation approach? If not, please state why and provide an alternative suggestion where possible.</p>	<p>We support the proposed approach whereby Ofgem would, if it meets timescales, decide on this mod this year for implementation, if approved, from 1/4/2020.</p>
<p>Do you have any other comments?</p>	<p>-</p>

CMP303 – Second Code Administrator Consultation - Response pro-forma

Industry parties are invited to respond to this consultation expressing their views and supplying the rationale for those views, particularly in respect of any specific questions detailed below.

Please send your responses by **2 October 2019** to cusc.team@nationalgrid.com. Please note that any responses received after the deadline or sent to a different email address may not receive due consideration by the CUSC Modifications Panel when it makes its final determination.

These responses will be included in the Final CUSC Modification Report which is submitted to the CUSC Modifications Panel.

Respondent:	<i>Joanna Chetwood</i> joanna.chetwood@vattenfall.com
Company Name:	<i>Vattenfall Wind Power Ltd</i>
Do you believe that the proposed original or any of the alternatives better facilitate the Applicable CUSC Objectives? Please include your reasoning.	<p>We welcome this second consultation round and that Ofgem has asked the CMP 303 working group to better substantiate the proposals made in the working group. Overall, we welcome CMP 303 as a long overdue recognition that the existing charging arrangements for HVDC links are not cost reflective and change is needed.</p> <p>In relation to the CUSC objectives we comment as follows.</p> <p>(a) Facilitation of competition.</p> <p>We consider the original and WACMs 1 – 3 (related to HVDC wider system benefits) better facilitate competition. The cost inclusion to local circuit TNUoS of HVDC converters as well as the HVDC cable is not wholly appropriate as the converters in particular provide wider system benefits, the cost or value of which should not be included in the local circuit charge. This current inclusion leads to very high local circuit TNUoS charges. This has been accepted as a barrier to generation on the Scottish Islands and the results of the recent CfD auctions back this up, particularly in relation to Shetland and the main project on the Western Isles (Stornoway Wind Farm) where no CfD were awarded.</p> <p>The case for removing some HVDC converter cost due to its wider system benefit was made during Ofgem’s own Project TransmiT and during CMP213 albeit rather qualitatively. The work now evidenced in CMP303 (please refer in particular to the work in Annex 9 and 10) shows how the wider system benefits can be quantified and local circuit TNUoS charges suitably adjusted. This work also refers clearly to similar work and conclusions published by CIGRE.</p>

Making this adjustment will remove the incorrect TNUoS charging penalty that generators 'using' HVDC links are currently liable for. This will assist in levelling the charging playing field and promote better competition.

(b) Better reflection of transmission party costs.

With reference also to our response to CUSC objective (a) above, transmission party costs are better reflected as the wider system benefits of HVDC links are costs that the transmission system operator (NGESO) and the transmission owners would normally incur either for service procurement, or, for the installation of their own plant.

For example, a reactive power and voltage control device such as a STATCOM would normally be installed by a transmission owner and the cost not targeted to any particular transmission users, or, the reactive power and voltage control service procured by NGESO from a generator. Under the present methodology, these HVDC wider system benefits are paid for solely by the generators liable for the local circuit charge which cannot be correct.

The above example also holds for the Power Control and Black Start wider system benefits examined in CMP 303 and more clearly in the Annex 9 and 10 papers.

(c) Takes account of the developments in transmission licensees' transmission businesses.

Please refer to the responses to CUSC objectives (a) and (b). the current methodology does not properly account for the development of HVDC links by the transmission licensees as part of their business (asset base) and how costs and value are allocated and accounted for. CMP 303 will better achieve this.

(d) Compliance with the Electricity Regulation and any relevant legally binding decision of the European Commission and/or the Agency. These are defined within the National Grid Electricity Transmission plc Licence under Standard Condition C10, paragraph 1*; and

CMP 303 proposals will maintain compliance in so far as we can see.

(e) Promoting efficiency in the implementation and

	<p>administration of the CUSC arrangements.</p> <p>CMP 303 we believe will be relatively neutral in this respect.</p> <p>The implementation of the CUSC may be slightly more complex with CMP 303, however, this needs to be taken in the overall context of charging which is already very complex and in the context of a very significant improvement in cost reflectivity.</p>
Do you support the proposed implementation approach? If not, please state why and provide an alternative suggestion where possible.	<p>We support the proposed implementation approach and in particular that of WACM 3 which is well substantiated by Annex 9 and 10, provides a clear method of implementation, and, is most cost reflective as it looks at each HVDC link on a case by case basis and shows (through Annex 9 and 10) that this is necessary.</p>
Do you have any other comments?	<p>None.</p>

CMP303 – Second Code Administrator Consultation - Response pro-forma

Industry parties are invited to respond to this consultation expressing their views and supplying the rationale for those views, particularly in respect of any specific questions detailed below.

Please send your responses by **2 October 2019** to cusc.team@nationalgrid.com. Please note that any responses received after the deadline or sent to a different email address may not receive due consideration by the CUSC Modifications Panel when it makes its final determination.

These responses will be included in the Final CUSC Modification Report which is submitted to the CUSC Modifications Panel.

Respondent:	<i>Paul Jones</i>
Company Name :	<i>Uniper UK Ltd</i>
Do you believe that the proposed original or any of the alternatives better facilitate the Applicable CUSC Objectives? Please include your reasoning.	<p>No, we continue to believe that the modifications are worse than the current baseline as they reduce cost reflectivity of the links and introduce discriminatory treatment compared with other elements of the transmission network. Our full comments in this respect can be found in our response to the original Code Administrator consultation.</p> <p>We believe that a more appropriate solution has already been implemented under CMP301.</p>
Do you support the proposed implementation approach? If not, please state why and provide an alternative suggestion where possible.	No, we do not support implementation of the modification.
Do you have any other comments?	<p>We note that in Ofgem's send back letter the workgroup was asked to provide further evidence as to why the alternatives which seek to remove various costs associated with converter stations from the charges, would be consistent with Ofgem's decision on CMP213. We believe that this was in response to a comment we made in our previous response on this modification, which pointed out that a conscious decision was made by the Authority when approving the chosen solution for CMP213 to include 100 percent of these costs. We quoted the relevant section of Ofgem's impact assessment for CMP213 in this response which said "<i>the investment in the HVDC converter stations (including the specific design elements) for bootstrap and island links arise specifically to serve those links and provide</i></p>

the required transmission capacity. Furthermore, our general view is that it is appropriate that costs that are being triggered by users are paid for by those users, to promote cost reflectivity and ensure efficient decisions”.

Indeed, in Ofgem’s decision letter, the Authority stated that they believed that the inclusion of these costs would be more cost reflective than not doing so as they said “*WACM2 also incorporates solutions for HVDC into the charging methodology. In doing so, it does not socialise any of the associated converter station costs. We have not seen strong enough evidence to avoid targeting the recovery of these costs from the users of the links.*”

Therefore, our assumption would have been that further evidence than that provided for CMP213 would have to be presented to Ofgem to change their opinion. There appears to be little provided in this respect in the new work group consultation although we note two potential new papers in appendix 9 and 10.

In the limited time provided for in this relatively short consultation period of 5 working days, it has not been possible to fully assess the implications of these papers, but they largely seem to summarise evidence which was provided at the time of CMP213 either in Project Transmit, CMP213 and the CIGRE documents. It did not appear to be new evidence as such. It also appeared to be mainly provided in support of WACM 3 to the modification which we understand to be very similar in nature to the changes introduced under CMP301. Therefore, we would suggest that this has been superseded by the decision to implement that modification proposal.

CMP303 – Second Code Administrator Consultation - Response pro-forma

Industry parties are invited to respond to this consultation expressing their views and supplying the rationale for those views, particularly in respect of any specific questions detailed below.

Please send your responses by **2 October 2019** to cusc.team@nationalgrid.com. Please note that any responses received after the deadline or sent to a different email address may not receive due consideration by the CUSC Modifications Panel when it makes its final determination.

These responses will be included in the Final CUSC Modification Report which is submitted to the CUSC Modifications Panel.

Respondent:	<i>Non- Disclosed Response</i>
Company Name:	<i>Non- Disclosed Response</i>
<p>Do you believe that the proposed original or any of the alternatives better facilitate the Applicable CUSC Objectives? Please include your reasoning.</p>	<p>[with the exception of WACMs 4,5,6 and 7]</p> <p>(a) Yes – the removal of additional costs that are unrelated to the generator’s needs will assist generators in market competition.</p> <p>(b) Yes – the proposal means the local circuit charge payable by the generator will be reflective of the costs incurred by the relevant transmission licensee in providing the required export capability (removing any extra costs unrelated to the required export capability).</p> <p>(c) Yes- this proposal will take account of developments in transmission licensees’ business such as providing HVDC links to remote island. The proposal will mean that costs unrelated to export capability are not assigned to generator local circuit tariffs.</p> <p>(d) Neutral</p> <p>(e) Neutral</p> <p>We are supportive of the original and WACMs 1 2, 3, 8 and 9 as shown in our previous voting statement. These WACMs provide various degrees of assistance in meeting the CUSC objectives.</p> <p>We note that since the original consultation, NGET have carried out detailed work to demonstrate the impact of these WACMs on demand tariffs.</p>

Do you support the proposed implementation approach? If not, please state why and provide an alternative suggestion where possible.	Yes
Do you have any other comments?	No