

The Power Potential Project A guide to participating

A technical guide to the services for
synchronous and non-synchronous DER
participants

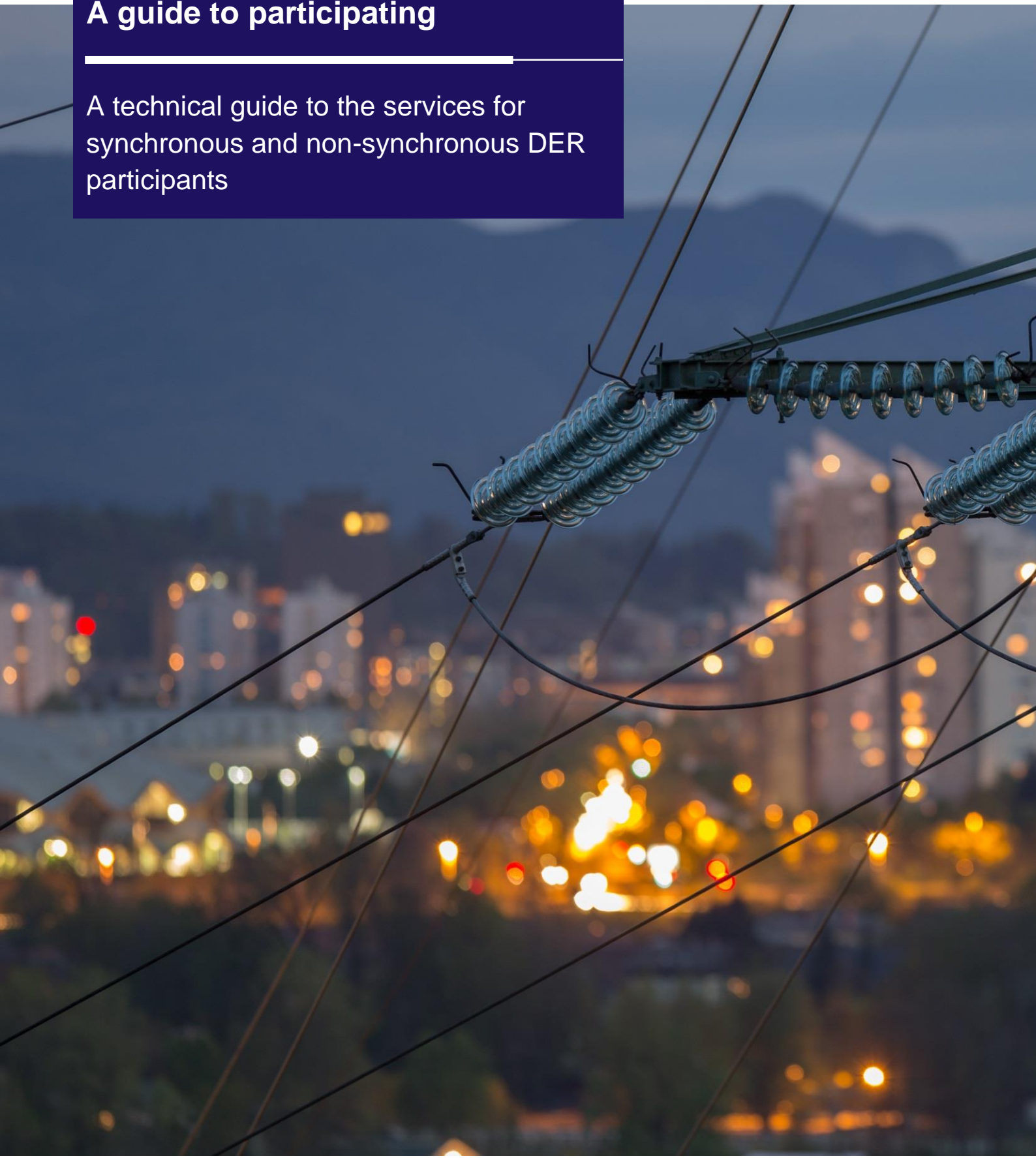

Table of Contents

Our vision	3
1. Introduction.....	4
2. What are the services being provided through Power Potential?	5
2.1 How are the services instructed?.....	5
2.2 Active Power service	5
2.3 Reactive Power service.....	5
2.4 Examples of service instructions	6
3. How do I know if my plant is suitable?	7
4. What are the next steps?	8
Appendix 1 – Voltage droop control for Reactive Power service.....	9
A1.1 Non-synchronous generators.....	9
A1.1.1 Power factor control	9
A1.1.2 Voltage droop control.....	10
A1.2 Synchronous generators.....	12
Appendix 2 – Do I need to make changes to my plant to take part in the Power Potential trial?.....	12
Appendix 3 – Heatmaps with effectiveness in respect to each Grid Supply Point (GSP)	14

Our vision

National Grid (NG) and UK Power Networks, together with the Office of Gas and Electricity Markets (OFGEM) and the Department for Business, Energy and Industrial Strategy (BEIS), have a shared vision for a more open and participatory power system.

The change in paradigm focuses on lowering barriers to entry to new markets and to enable more distributed energy resources (DER) to provide active and reactive power services. This would result in increased competition, leading to lower prices for electricity customers, and would support the delivery of the UK's power system decarbonisation targets.

The **Power Potential** innovation project is a joint venture between National Grid and UK Power Networks. The project trial will provide opportunities for DER participants to provide new services to the electricity transmission system. This will create new revenue opportunities and establish new business models for the development and operation of DER. Through this trial, DER will support the transmission system with both reactive and active power services in the South-East of England.

National Grid and UK Power Networks would like you to consider taking part in the Power Potential trial which could result in an additional revenue stream for your plant.

1. Introduction

The following generators/plants connected in the South-East coast area of England are encouraged to participate in the Power Potential trial:

- PV power plants
- wind farms
- batteries and storage sites
- synchronous generators
- aggregators
- other distributed energy resources not reflected in this list.

Ideally, connected at 33 kV or above for most effectiveness with a capacity of 1 MW \geq

Before deciding to take part in the trial there are a number of points you may need to consider. They include:

- what are the services to be provided through Power Potential?
- how do I know if my plant is suitable?
- do I need to make any changes to my plant to take part?
- what are the next steps?

This document is designed to help you answer these technical questions and to inform your decision to take part in Power Potential project trial.

2. What are the services being provided through Power Potential?

In order to take part in the Power Potential trial, a DER generator/plant will be requested to be capable of controlling at least one of the following two aspects of its operation:

- active power generated
- reactive power generated or absorbed.

We encourage all participants to deliver both if possible.

2.1 How are the services instructed?

Instructions for active and reactive power service are sent from UK Power Networks to the DER generator via the Power Potential platform. This provides transmission services to National Grid.

DER generators would be instructed by UK Power Networks using voltage droop control. This is for the reactive power service and to an active power MW set-point for the active power service. In both cases, the performance capability of the generator would be respected.

2.2 Active power service

The active power service relates to the active power generated from the participating DER plant. It will need to be capable of automatically ramping up or down the active power generated according to instruction, and within the plant limitations. This service is expected to help improve the management of system constraints. It will be exercised depending on the cost compared to other options in the area.

Providing this service means the plant should be ready to change its active power output upon an instruction from UK Power Networks. The plant response should be automatic and within its pre-defined limits and ramp rates.

2.3 Reactive power service

The reactive power service relates to the reactive power generated or absorbed by the participating DER plant. This production/absorption of reactive power would allow more effective control of the voltage in the distribution and transmission systems. To do this, an automatic response enabled through a voltage droop control is required. This control system will automatically respond to voltage changes measured at the point of connection. Any change in voltage target set point received electronically should be acted on within two seconds.

A short description of voltage droop control is contained in Appendix 1 of this document. The technical requirements for the reactive power provider are described next.

A capability equivalent to 32% of the maximum export capacity (in MW) is required to be delivered or absorbed at the point of connection (i.e. capability to provide 0.95 power factor lagging or leading at the generator terminals).

Example: a 10 MW plant should be capable of delivering or absorbing 3.2 Mvar across its operating range (including at full power generation) at its point of connection).

If your plant already exists, please tell us what can be delivered at the plant connection point and we will advise if it is suitable for the trial. You can contact us at: box.powerpotential1@nationalgrid.com
Being capable of delivering the reactive power service when there is no sun (for PV power plants – sometimes called ‘Q at night’) and when there is no wind (for wind farms – sometimes called ‘STATCOM mode’) is considered very advantageous for the Power Potential trial. Similarly, storage

sites capable of 'STATCOM mode', where they can deliver reactive power even if they are not charging or discharging, are particularly valued.

The DER plant should be capable of moving the operating point 90% of the possible change from full lead (importing reactive power) to full lag (exporting reactive power) within two seconds.

2.4 Examples of service instructions

Some examples are detailed next to give the prospective DER participant an idea of the frequency of the services being provided through the Power Potential project.

- **Scenario 1:** Reactive power service to manage transmission high voltage.

Instruction to absorb reactive power to manage high grid voltages, especially during nights (all year round) and in the weekends when embedded generation suppresses system demand. Frequency of service instruction: **very frequent**.

- **Scenario 2:** Reactive power service to manage a transmission voltage export constraint.

The use of the service in this scenario is driven by outages on the transmission system and by interconnector flows on the South-East coast. This is during times of peak system demand when interconnectors are flowing at full capacity into the Great Britain system. Frequency of service instruction: **frequent**.

- **Scenario 3:** Active power service to manage a transmission thermal constraint.

The instruction is to reduce active power to manage flows on the transmission system so they remain within acceptable asset short term ratings. The requirement for the service is driven by planned and unplanned transmission outages. Also by existing and future interconnector flows and active power exports from the DNO network. Frequency of service instruction: **not frequent**.

3. How do I know if my plant is suitable?

If a DER generator has the capability to provide active and/or reactive power service, it is a likely candidate to participate in the Power Potential trial. To participate in the reactive power service, a suitable control system is required to provide voltage droop control at the connection point (see Appendix 1).

Technical specifications related to generator capabilities can be discussed with the Power Potential project team and where feasible, we will try and accommodate all potential participants within the trial. For guidance, Appendix 2 of this document provides the expected communication requirements for the Power Potential trial.

To check the efficiency of a DER generator in providing the reactive power service, heatmaps are available in Appendix 3. These indicate the value of the service depending on the generator's location for different system conditions. An example of a heatmap is presented in Figure 1. The colour coded map shows the effectiveness of different DER locations to provide reactive power service at a particular Grid Supply Point (GSP).

Key:

Green areas = high effective

Yellow areas = good effective

Red = low effective.

Figure 1- Example of heatmap for effectiveness with respect to Ninfield GSP. Location of the GSP shown with a black cube.

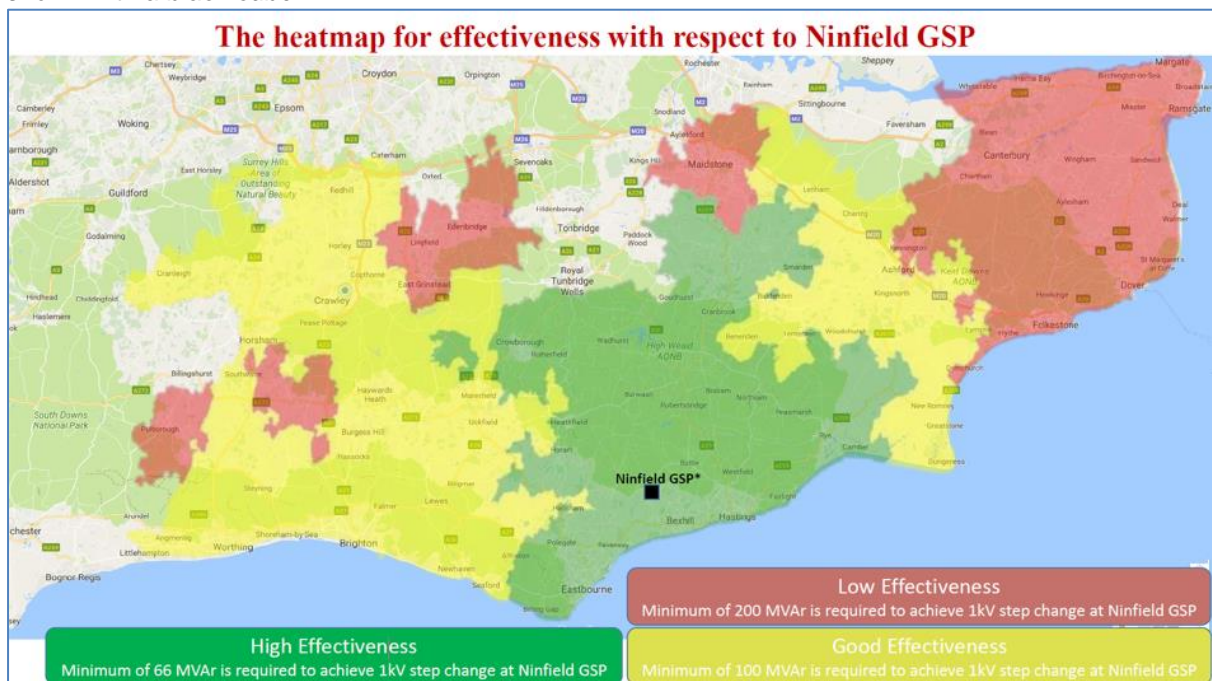

We hope that this document has provided clarity on the opportunity to participate in Power Potential. If you have any outstanding questions, there are a number of options. Your engineering, procurement and construction (EPC) providers or engineering teams may be able to provide bespoke guidance on whether your asset(s) need be modified to participate.

Alternatively, please contact the Power Potential team for more information on the project at box.powerpotential1@nationalgrid.com.

4. What are the next steps?

After reading this document, you should:

- determine the capability and changes (if any) you would need to make to your generation plant to be able to participate with your engineering teams / consultants / EPC providers,
- decide which services you would be able to offer
- with your commercial team, assess if taking part in the trial will be cost effective

Contact:

If you decide you want to participate, or have any questions relating to this document or the project in general, contact us: box.PowerPotential1@nationalgrid.com

Information:

For more information on the Power Potential project, please visit our website:

www.nationalgrid.com/powerpotential

1. Appendix 1 – Voltage droop control for the reactive power service

Under the reactive power service, synchronous and non-synchronous DER will follow a voltage droop control scheme to regulate their terminal bus bar voltage in order to provide reactive power support. An overview of this type of control is shown in Figure 2. Note the reactive power transfer in either direction is proportional to the difference between the actual measured voltage and a desired voltage target. Use of voltage droop control for synchronous and non-synchronous DER with respect to their normal operation is described in detail in the next subsections.

Figure 2 – Example of DER providing reactive power service

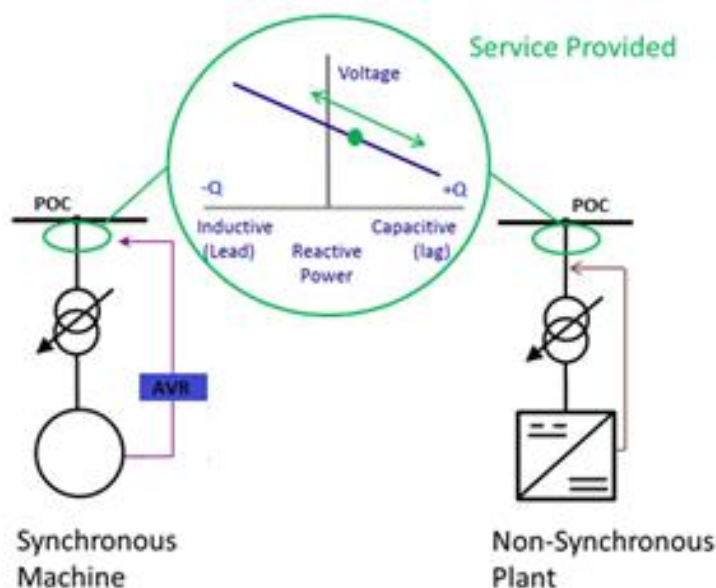

A1.1 Non-synchronous generators

Power factor and voltage droop methods for non-synchronous generators are described below. Commonly, non-synchronous DER are normally operated under power factor control mode. In order to provide the Reactive Power service under Power Potential, voltage droop control operation is required. This may be applied at the point of connection, or even at the inverter terminals, depending on the requirements in the plant connection agreement.

A1.1.1 Power factor control

Under power factor control a central controller monitors the reactive power exchange at the point of connection and adjusts the reactive power of the generation plant to maintain the desired power factor. In absence of central controller, it is likely that the inverters are set to unity power factor (no reactive power exchange). Figure 3 shows a leading power factor control strategy by the blue dotted line.

Figure 3 - Power factor and constant reactive power mode of operation

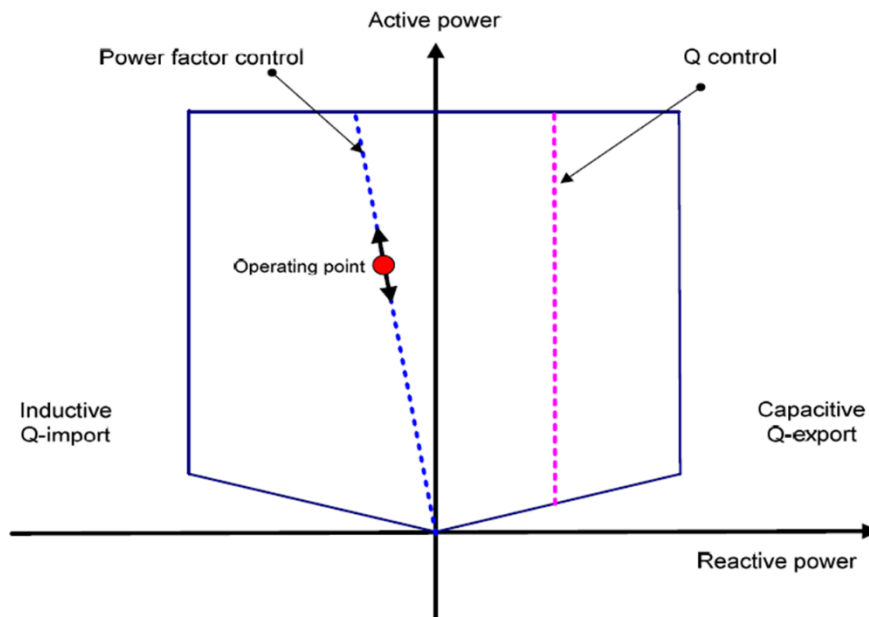

A1.1.2 Voltage droop control

In most cases a DER generator will be small compared to the network it is connected to. If voltage control is required, it is not considered appropriate to control the point of connection voltage to a target value. This is because it would normally result in the plant operating at full reactive capacity for the majority of time. Instead, it is typical to control the reactive power export based on a voltage target set point (at the point of connection) and a reactive power slope, otherwise known as voltage droop control.

Example: Figure 4 shows the voltage droop control of a generator with 0.95 power factor leading and lagging capability. In the example, there is a target of 1pu and a slope of 4%. Therefore, if the point of connection voltage is at 1pu then the generator will operate at unity power factor (0 Mvar) at the point of connection. If the point of connection voltage drops to 0.96pu, then the generator will export Mvar equivalent to 0.95 power factor (calculated based on rated MW). Conversely, if the voltage at the point of connection voltage increases to 1.04pu then the generation plant will import Mvar equivalent to 0.95 power factor.

Figure 4 - Voltage vs. reactive power: droop control approach

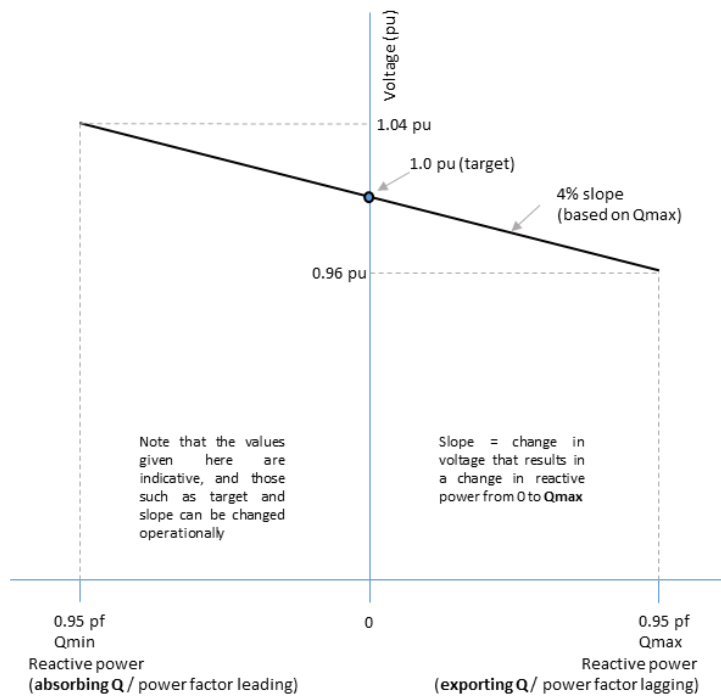

The Power Potential control system can also adjust the voltage target to move the slope to achieve different response to voltage changes as shown in Figure 2.

Figure 5 – Voltage target set point adjustment

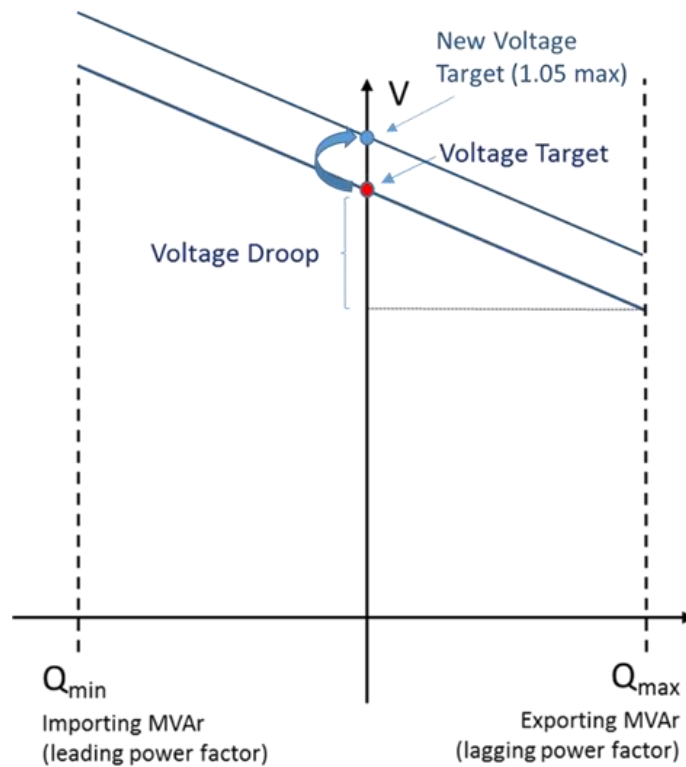

A1.2 Synchronous generators

Synchronous generators (or synchronous motors) providing a reactive power service must be capable to change the reactive power supplied to the distribution system. It is embedded to contribute to voltage control.

An automatic voltage regulator (AVR) is required to provide constant terminal voltage control of the synchronous generating unit without instability over its entire operating range. An AVR is a continuously acting automatic excitation control system. A voltage control through a droop characteristic is also required for participation in the reactive power service. Therefore, the voltage droop control concept described in subsection A1.1.2 is also valid for this case.

Appendix 2 – Do I need to make changes to my plant to take part in the Power Potential trial?

Figure 6 helps to explain the equipment that is typically required to enable sites to deliver the active and reactive power services under Power Potential trial. A solar PV power plant is used as an illustrative example. However, this is relevant to other assets such as wind and battery technologies.

Note that this information is designed as a guide, and you should discuss with your engineering teams, consultants and EPCs to determine what is required for your specific plant.

Figure 6 - Control of a PV power plant to provide active and reactive power services

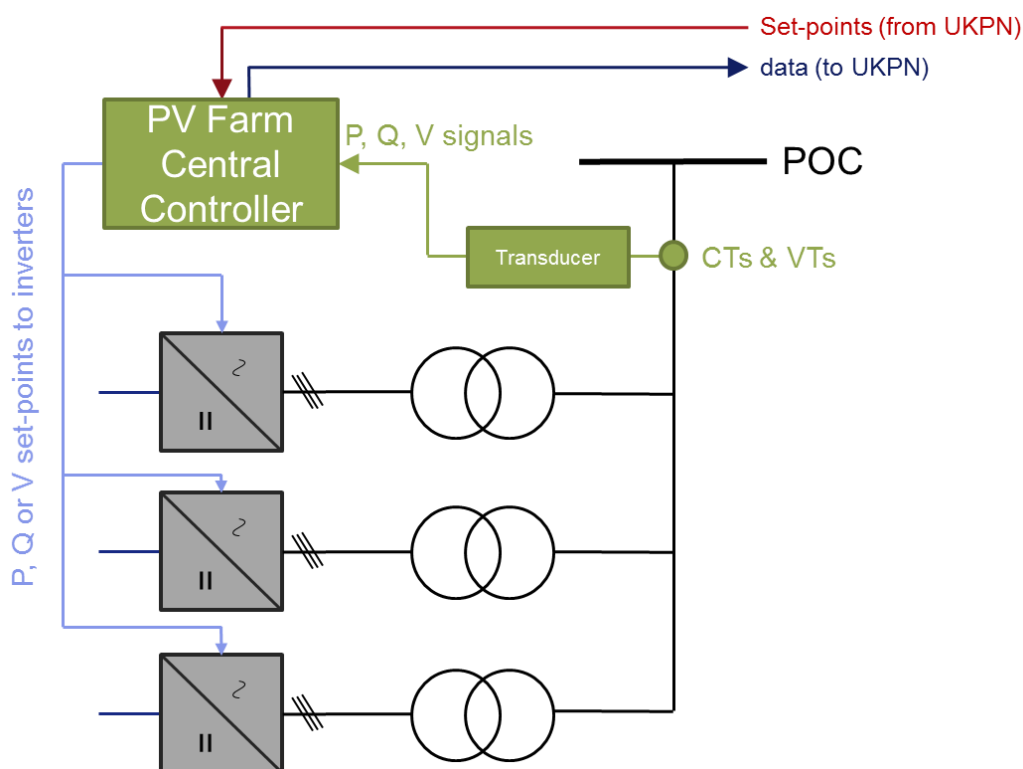

For the Power Potential trial, it is necessary to control active and/or reactive power flow from the plant to make the site behave like 'one virtual generator' at the point of connection. To achieve this, a central controller is needed. This 'brain' takes measurements from the point of connection and signals from the grid operator (in this case UK Power Networks via the Power Potential control platform) and then controls each inverter to give the desired output at the point of connection.

The following items are required to practically enable this control:

- a central control system
- communication links: from UK Power Networks to the central controller and from the central controller to the inverters and to the measurement devices.
- Measurement equipment: transducers and current and voltage transformers (CTs and VTs) for measuring active power, reactive power and voltage at the point of connection.

Depending on the manufacturer the inverters may require an upgrade to provide reactive power in STATCOM mode (e.g. 'Q at night' function for PV power plant).

Depending on the site and how it was designed most of the above items may already be present. Certainly, the fibre communication between the customer substation and the inverters is often installed along with the cable, even if it is not used, as it is very costly to retrofit this at a later date.

In addition to these communication requirements, changes to the operating regime of the generation plant by providing a 24/7 service may change asset running hours. It is recommended that you contact your engineering team to discuss any impact that you would have to consider.

Further reading:

For more information, please read our [DER Technical Requirements document](#). This document sets out all the functional and non-functional requirements for DER participating in the Power Potential trials. It includes the interface requirements with the UK Power Networks RTU. It also sets out how requirements will be tested before the trial - initial desktop assessment, laboratory assessment and final site commissioning including performance testing. We hope you find it useful

Appendix 3 – Heatmaps with effectiveness in respect to each GSP

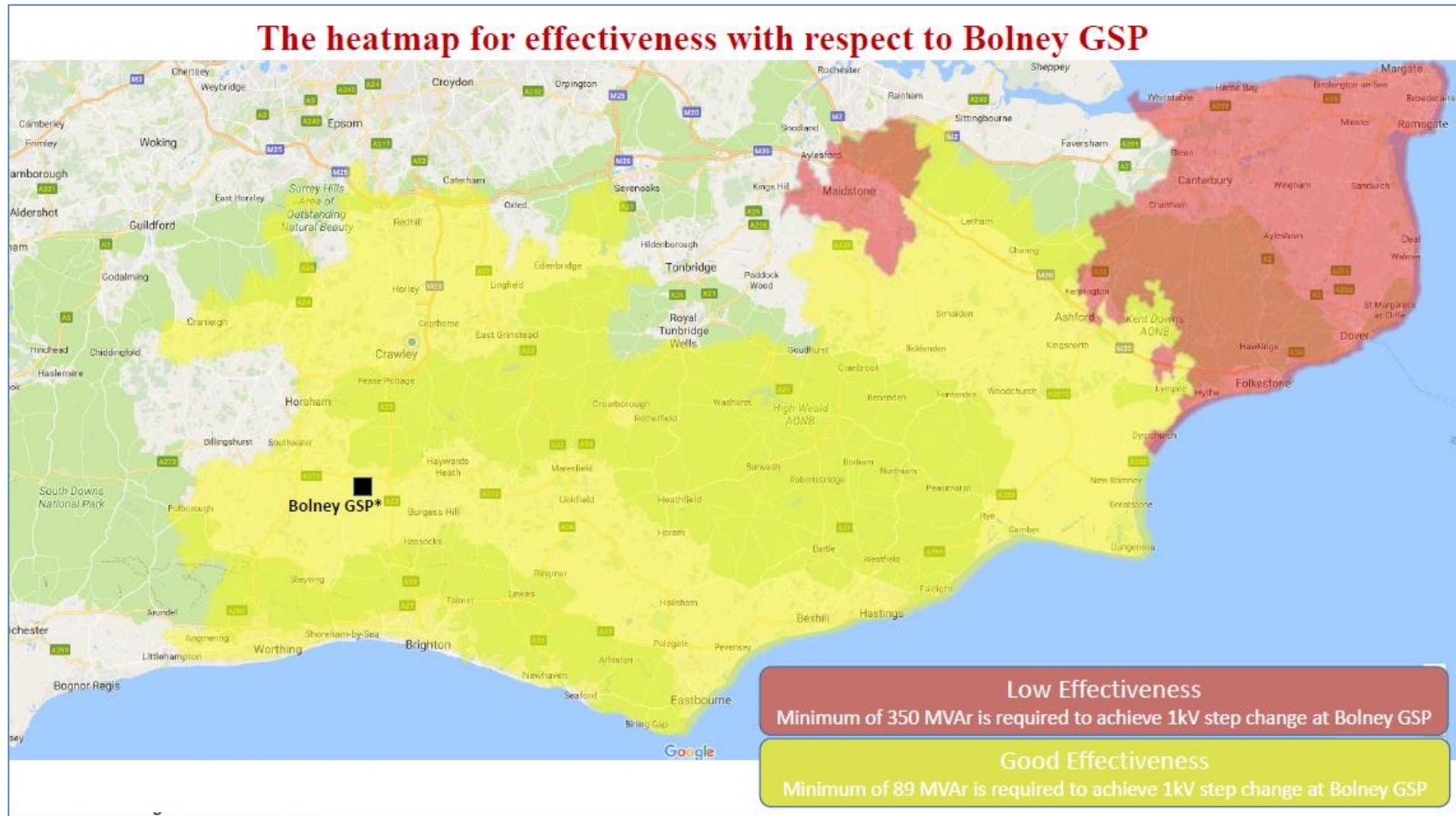

The heatmap for effectiveness with respect to Ninfield GSP

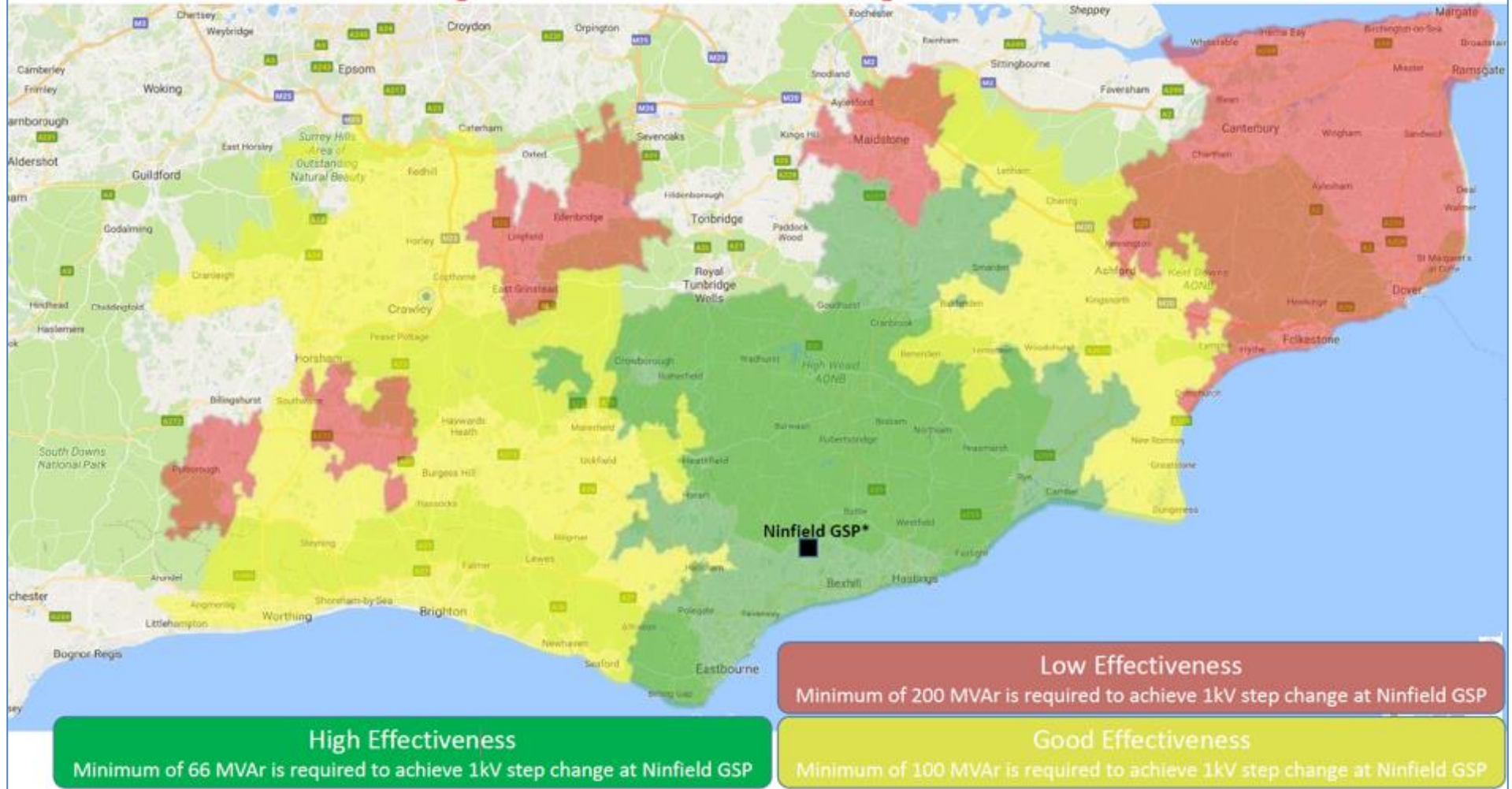

The heatmap for effectiveness with respect to Sellindge GSP

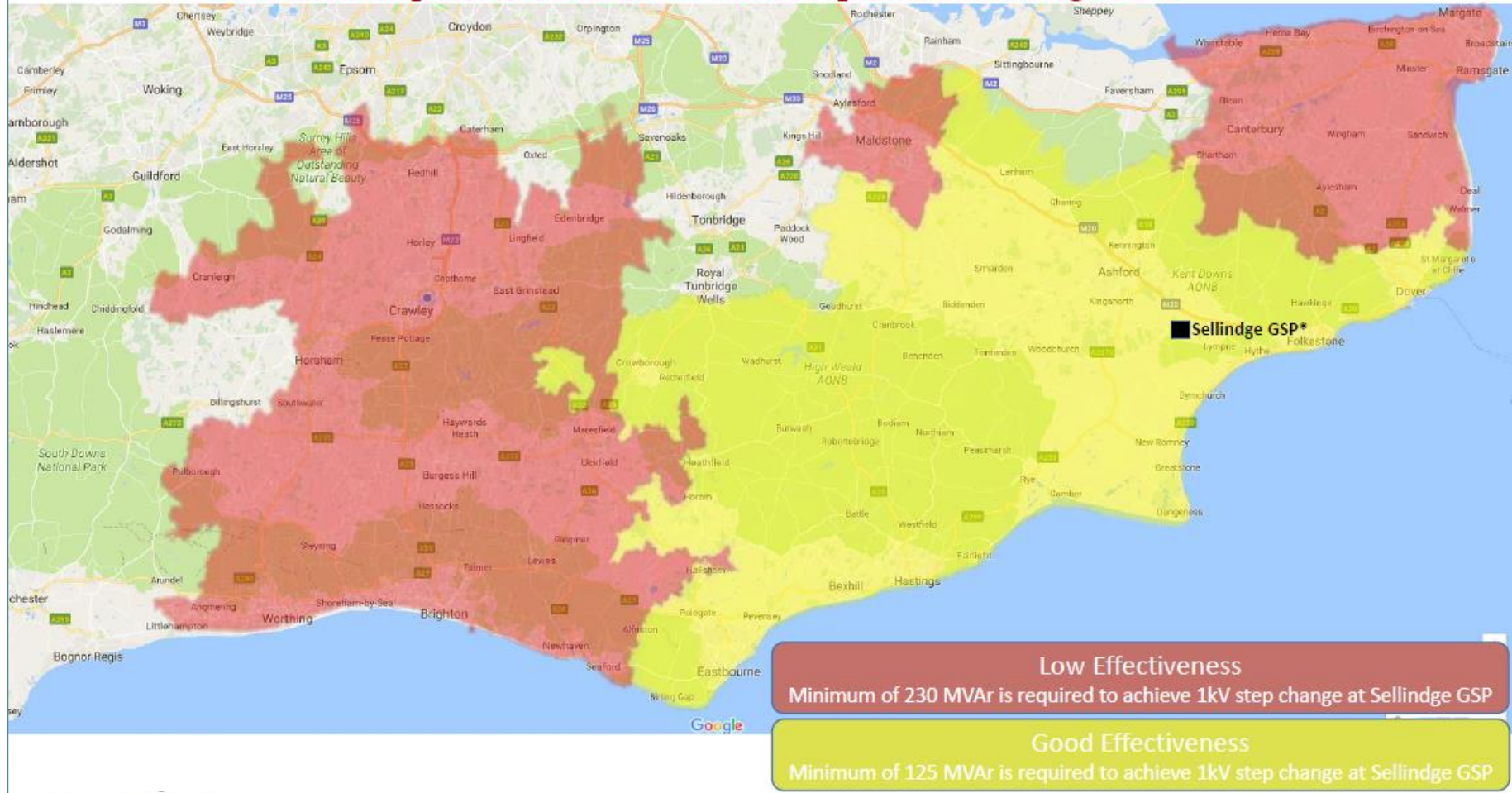

The heatmap for effectiveness with respect to Canterbury GSP

